



**Politecnico  
di Torino**

**Department of Management and Production Engineering**

**Master's Thesis in Engineering and Management**

**Maintenance Strategies for Industrial Machinery**

**Supervisor: Prof. Giulia Bruno**

**Candidate: Abdurakhmon Olimjonov**

**Student ID: S273764**

2023-2024

# Abstract

---

This thesis explores the maintenance strategies employed by an industrial machinery company, focusing on the inspection and repair of pallets. It presents a comprehensive analysis of the company's maintenance operations, comparing them with industry standards and practices found in the literature. By examining reactive, preventive, and predictive maintenance strategies, this study highlights the strengths and weaknesses of the current operations. The analysis includes a detailed examination of Overall Equipment Effectiveness (OEE), cost monitoring, and safety protocols.

Recommendations for integrating advanced predictive maintenance technologies and optimizing maintenance strategies are provided to enhance operational efficiency and reduce costs. This work aims to contribute to the field of industrial maintenance by offering actionable insights for improving maintenance practices in manufacturing settings.

# Table of Contents

<b>Abstract .....</b>	<b>2</b>
<b>I. Introduction .....</b>	<b>5</b>
<b>II. Background .....</b>	<b>6</b>
2.1. Standards of Professional Maintenance .....	6
2.1.1. ISO 55000 Asset Management Standards .....	7
2.1.2. ISO 13374 on Condition Monitoring and Diagnostics of Machines .....	7
2.1.3. MIMOSA Open Information Standards .....	8
2.1.4. ANSI TAPPI TIP 0305-34:2008 .....	8
2.2. Industrial Internet Consortium Reference Architecture .....	9
2.3. Quality Standards .....	10
2.4. Quantity Standards .....	13
2.5. Performance Standards .....	14
<b>III. Types of Maintenance in Manufacturing.....</b>	<b>16</b>
3.1. Introduction .....	16
3.2. Different types of Maintenance .....	17
3.2.1 Reactive Maintenance.....	17
3.2.2. Preventive Maintenance.....	18
3.2.3. Condition-Based Maintenance .....	18
3.2.4. Predictive Maintenance .....	19
3.2.5 Prescriptive Maintenance.....	20
3.2.5.1. Maturity state of Prescriptive Maintenance .....	20
3.3. Benefits of Industrial Maintenance .....	21
<b>IV. The Industrial Maintenance System Approach .....</b>	<b>22</b>
4.1. Objectives of Maintenance Management System .....	22
4.2. Inventory of Highway Features.....	22
4.3. Tracking Maintenance History.....	24
4.3.1. Fundamental Ideas.....	25
4.3.2. Contract Smart .....	26
4.3.3. Applications of Blockchain in the Automotive Sector .....	26
4.4. Following Management Practices .....	27
4.5. Overall Equipment Effectiveness (OEE).....	27
4.6. Monitoring all costs.....	28
4.7. Tag Assets .....	28
4.8 Creating Emergency Plans .....	29
<b>V. Company description .....</b>	<b>31</b>
5.1 History of The Company .....	31
5.2. Structure and Working Process of The Machinery .....	31
5.2.1 Zone A1 Infeed .....	32
5.2.2. Zone A2 Inspection and Repairation .....	33
5.2.3 Zone A3 Robot(Klippa).....	33
5.2.4. Zone A4 Outfeed, sorting and stacking .....	34
Fig 6. Zone A4 Outfeed, sorting and stacking.....	35
5.3. Operating Mode (Program).....	35
5.4. Electric zone and Safety devices .....	36
5.5. General Description of Operation. SCADA / HMI .....	37
5.6. Safety Instructions for Machinery Use .....	38
5.6.1. Objective.....	38
5.6.2. Responsibility.....	38
5.6.3. Special attention should be given to .....	38

5.7. Safe Use of The Installation and Description of The Flow .....	38
5.7.1. Protective Devices .....	39
5.7.2. Commissioning Procedure .....	40
5.7.3. Preliminary Considerations .....	40
5.7.4. Startup Procedure .....	40
5.7.5. Instructions for Safe Work.....	40
5.7.6. Equipment Shutdown Procedure.....	42
5.7.7. Procedure in Case of Malfunction.....	42
5.7.8. Signs .....	42
<b>VI. Company proposal.....</b>	<b>46</b>
6.1. Regular Analysis and Checks.....	46
6.1.1. DAILY CHECK.....	46
6.1.2. WEEKLY CHECK.....	46
6.1.3. MONTHLY CHECK.....	46
6.1.4. HALF YEARLY CHECK .....	47
6.1.5. ALARMS.....	47
6.2. Safety Reparation Rules for The Machinery.....	50
6.2.1. Unstacker with 4 forks.....	50
6.2.1.1. Missions of the maintenance technicians .....	51
6.2.1.2. Types of risks.....	51
6.2.1.3. Corrective measures (by the manufacturer).....	52
6.2.2. Repair table (without enclosure, unique product).....	52
6.2.2.1. Missions of the maintenance technicians. ....	53
6.2.2.2. Types of risks.....	53
Mechanical risks: .....	53
6.2.2.3. Corrective measures (by the manufacturer).....	54
6.2.3. Stacker (Fenced, Stack) .....	54
6.2.3.1. Missions of the maintenance technicians .....	54
6.2.3.3. Corrective measures (by the manufacturer).....	55
6.3. Critical Analysis of Maintenance Operations .....	56
6.3.1. Comparison with Literature .....	56
6.3.2. Pros and Cons .....	56
<b>VII. Conclusions.....</b>	<b>58</b>
<b>References.....</b>	<b>59</b>
<b>Acknowledgements.....</b>	<b>62</b>

# I. Introduction

---

Maintenance is a pivotal aspect of industrial operations, ensuring that machinery and equipment operate efficiently and safely. Effective maintenance strategies can significantly influence the performance, service life, and cost-efficiency of industrial systems. As industries evolve with advancements in technology, maintenance practices must adapt to leverage new tools and methodologies. This thesis investigates the maintenance operations of a company specializing in the inspection and repair of pallets, aiming to provide a comprehensive analysis of current practices and suggest improvements based on established literature.

The research is structured into two main parts: a theoretical review and a practical case study. The theoretical part includes an extensive literature review on various maintenance strategies, including reactive, preventive, and predictive maintenance. Reactive maintenance, although necessary in some scenarios, often results in higher costs and increased downtime. Preventive maintenance aims to mitigate these issues by scheduling regular inspections and repairs, thereby extending equipment life and reducing unexpected failures. Predictive maintenance, enhanced by IoT devices and machine learning, offers further optimization by predicting failures and allowing maintenance to be scheduled just in time.

The practical part involves a detailed examination of the company's existing maintenance operations. By comparing these practices with those found in the literature, the study identifies strengths and weaknesses in the current approach. Key areas of focus include Overall Equipment Effectiveness (OEE), cost monitoring, and safety protocols. The analysis reveals that while the company has well-structured maintenance procedures and emphasizes safety, there is a notable reliance on reactive maintenance. This dependency can lead to higher operational costs and unplanned downtime.

The primary objective of this thesis is to provide actionable insights for enhancing the company's maintenance practices. Recommendations include integrating advanced predictive maintenance technologies, conducting detailed cost-benefit analyses, and optimizing the balance between reactive and preventive maintenance strategies. By implementing these recommendations, the company can improve operational efficiency, reduce maintenance costs, and enhance overall equipment effectiveness. This study aims to contribute to the field of industrial maintenance by offering practical solutions for improving maintenance practices in manufacturing settings, ultimately fostering greater efficiency and cost savings.

## II. Background

---

### 2.1. Standards of Professional Maintenance

There are clear benefits to using standards-based systems and processes over private ones. This is because standards cover tried-and-true methods that users can adapt to their own needs. Some of these benefits are that systems can work with each other, systems and best practices can be copied and used again and again, and technology lasts for a long time.

Systems and methods for maintenance are no different. Standards for service include tried-and-true ways to do things like cleaning, lubricating, repairing, replacing parts, gathering data, and more. Also, they can teach technicians how to make complete lists of maintenance jobs and how

to organize those lists into plans for integrated maintenance. When used with technology platforms, standards are helpful.

For instance, they can push for the creation of open systems that can share data and services so that service decisions can be used again and again. This sharing and exchanging of data is very important for getting different groups of people to agree on things and for backing new, low-cost ideas for online maintenance. Overall, systems and procedures that are built on standards make sure that repair practices work well for a wide range of installations, tools, and methods. Many service standards have been made by groups like the American National Standards Institute (ANSI), the International Electrotechnical Commission (IEC), the International Organization for Standardization (ISO), and others. These standards cover both systems and repair processes. They also cover new cyber-physical systems that are being used as part of the digitalization of industry. New systems have increased the number and types of service standards because they make it possible to gather, share, and process data. There are so many standards that it would be hard for an expert to learn all the suggested ways of doing things. Instead, professionals tend to focus on just a few standards, especially those that are important to the repair work they are currently doing. The guidelines below are five important rules that people who work in the service industry should be aware of.[38–39]

International service standards can be different based on the business and the systems or equipment that need to be kept. There are, however, some rules and standards that most groups choose to follow.

### 2.1.1. ISO 55000 Asset Management Standards

Real assets include things like plant parts and tools. Asset management methods and disciplines are used to take care of these.

The goal of asset management is to coordinate and improve the management of an asset throughout its entire lifetime, which includes choosing, buying, developing, maintaining, renewing, and getting rid of it. There are ISO 55000 standards in English, French, Spanish, Russian, Chinese, Japanese, Dutch, Swedish, Brazilian, and Portuguese, among other languages. ISO 55000 is made up of three asset management standards:

- The ISO 55000 standard explains what asset management is and how it works. It also gives words and definitions for the standard.
- ISO 55001 sets the standards for efficient and integrated asset management systems in the same way that ISO 9001 sets the standards for quality management[40].
- ISO 55002 gives advice on how to set up asset management systems that are in line with older ISO 55000 family standards[41].

ISO 55000 not only describes asset management processes and how they should be carried out, but it also gives people who are already using asset management a way to check whether their methods are full and suggest ways to make processes better.

As an example, the consulting and training company Assetivity has been checking HYDRO Tasmania's asset management systems to see if they comply with ISO 55000 and making suggestions for how they can be made even better.

## 2.1.2. ISO 13374 on Condition Monitoring and Diagnostics of Machines

Maintenance systems and methods, like condition-based, preventive, and predictive maintenance, depend on being able to share and distribute data quickly and easily.

Furthermore, data connectivity is needed not only to share data between systems but also to install systems in a way that requires little or no integration work.

Putting together different kinds of information is easier with the ISO 13374 line of standards. It gives you unified and compatible ways to process, communicate, and show data across various support systems, without worrying about which provider you're using. The four parts that make up ISO 13374 deal with[42]:

- Presentation of general guidelines for data communication and processing
- Data-processing requirements
- Communication requirements
- Presentation requirements

Companies that do maintenance, like Turbomonitoring, say that ISO 13374 is one of the best standards for gathering and handling vibration data to find out how healthy their machines are and if there are any design flaws or damages. Vibration and damage research is one of the most common ways that ISO 13374 is used.

## 2.1.3. MIMOSA Open Information Standards

A trade group called MIMOSA, which doesn't make money, creates open information guidelines for Operations and Maintenance (O&M) in areas like factory, fleet, and facility settings. The MIMOSA group has a lot of different protocols that cover almost every part of exchanging data and integrating different O&M systems. The Common Collaborative Object Model (MIMOSA CCOM) makes it easier for systems to work together by providing a way to share information about assets. It lets systems share data electronically using an XML-compliant model, similar to how the well-known EDI model lets systems and processes exchange information electronically.

Keep in mind that one of the MIMOSA standards, OSA-CBM, describes in detail how to apply the ISO-13374 standards we talked about above. It includes specific data requirements for the ISO standard's feature blocks. So, the MIMOSA standards can also be used to make sure that different maintenance datasets (data sets from different systems and devices) can work together. They can also be used to make it easier for maintenance partners to share data.[43].

## 2.1.4. ANSI TAPPI TIP 0305-34:2008

Technical Information Paper TIP 0305-34 specifies this standard, which tells you how to make maintenance plans every day, every week, or every month.

In real life, repair engineers and other users should change these checklists to fit the needs of their plant, taking into account the tools, equipment, layout, and other features of the plant. Research studies and real-world examples have shown that maintenance plans are very helpful for keeping upkeep focused and efficient. Following the TAPPI TP 0305-34:2008 standard is a useful way to make and keep a meaningful plan[44].

## 2.2. Industrial Internet Consortium Reference Architecture

In earlier posts, we talked about how industries are becoming more digital and how new technologies like the Internet of Things (IoT) and BigData can be used to their full potential.

The Industrial Internet Consortium Reference Architecture lays out the rules for how Industrial Internet applications should be put together as part of the industry's move toward digitization. The Industrial Internet Consortium Reference Architecture is the result of work done together by big industrial and IT companies around the world. It shows that they all want products to be able to work with each other and make building industrial internet systems easier. The design can be used in many areas, such as healthcare, industry, transportation, and energy.

The Industrial Internet Consortium Reference Architecture makes it possible to create maintenance apps that are flexible and can work with other apps, like predicted maintenance. In particular, it spells out the standards for connection, as well as those for data representation and sharing. The last set of needs can generally be met by adding the Data Distribution Service for Real-time Systems (DDS) from the Object Management Group.

This led to the creation and use of data sharing systems that are compliant with the Industrial Internet Consortium Reference Architecture. Platform makers, system developers, OEMs, and Cloud service providers use the second type to offer unified IoT solutions for specific markets like healthcare, energy, transportation, and industrial automation.

As was already said, the list of guidelines above is by no means complete. Still, it gives you an idea of how deep and wide the standards are that are currently open for upkeep. Along with the list of functions, there is a set of guidelines that can help the complex systems work better. Organizations' needs and ways of storing data are always changing. When changing the way maintenance is done now to fit these new requirements, you should look at both existing and new maintenance standards to see which ones would work best for the organization's structure.

## 2.3. Quality Standards

One goal of quality standards is to set the minimum levels at which certain upkeep tasks should be done. They come up with a way to improve output while keeping the main goals of the maintenance policy in mind. As well as telling you when to move, they may also say what kind of action you should take. During the system design process, many states have made department policy statements that spell out the official goals for upkeep.

While the current methods are good in some ways, they are very weak when it comes to quality standards. Most of the newer systems have chosen not to include quality standards in their designs. People may not follow quality standards, which set an official minimum level above which certain route features should be kept, because they are afraid of what the law might say. If an accident happens because of a situation that isn't up to par, responsibility may come into play, which wasn't the case before a quality standard was put in place. But there aren't any examples that back up this fear[1].

Ohio hasn't made a maintenance management system yet, but they have hired consultants to do a lot of research on the quality of upkeep [2]. It looks like Ohio thinks that measuring repair quality levels in a fair and accurate way is the most important management tool the highway maintenance group has access to.

This topic has been written about a lot, and it seems that only five or six states have clearly built quality standards into their systems in a way that makes them flexible enough to react to changes in future state, federal, and foreign research efforts that involve quality levels. One of the clearest



ways to set quality standards can be seen in Pennsylvania's system documents, which is shown below:

The quality standards describe how a highway and all of its parts should look if (1) it is to be kept in as close to its original condition as built or its improved condition after construction; and (2) it is to provide safe, convenient, and affordable highway transportation. Quality standards spell out the amount of service that the repair work should provide. These standards are meant to help a boss do their job and make sure that everyone in the state gets the same amount of service.

The level of service shows how well the whole highway meets the wants of the person. When it comes to this situation, a highway meets the wants of the person when the quality standards are met. The Department will decide the amount of service that will be given on the State Highway System. The goal is to facilitate "obstruction-free" travel in line with the State Highway Law. The following things are used to decide the level of service:

- Safety
- Preservation of the highway facility
- Public Comfort and Convenience
- Aesthetics

Also, the type of service that is supposed to be given may change the amount of service that is supposed to be provided. Keeping up with how Pennsylvania handles quality standards:

Standards for Quality To come up with, measure, and write down the Quality Standards, subcommittees are formed with staff from the Central Office, the Engineering District, and the Maintenance District. It is important that each standard set a level of service that makes highway travel safe, easy, and affordable in order to do its job.

The Quality Standards will be sent to the department for use after they have been approved by management. After that, standards will be looked at again and changed as needed. The Quality Standards are only made public so that workers of the (department) can learn from them and follow them. [3]

It looks like the last sentence was added to get rid of the possible legal consequences that were already mentioned. At the time of this study, there were no examples of the quality standards that came from the above method.

The way California handles quality standards is shown in the following excerpts:

- **Maintenance Levels:**

The level of effort required for maintenance activities has been defined.

- **Joint Separation:**

When PCC (Portland Cement Concrete) sidewalk joints open up, water can get to the structure layers below. This usually causes the slab to rock, which then causes the beneath materials to be pumped through the joint and cause the slab to finally break.

When there is joint separation between PCC sidewalk and neighboring AC (Asphalt Concrete) shoulders, surface runoff can get into the structural section, which often leads to shoulder failure. In addition, it gives room for plants that you don't want to grow to grow.

When you see signs of pumping, joints in PCC paving should be covered. If the gap between the PCC sidewalk and AC sides is more than 4 inches, the joint needs to be filled [4]. The following is part of California's standard for fixing roads by hand:

- **Desired Maintenance Level:**

Patch when there are depressions in the wheels that are more than 1 inch deep, drip tracks, or a vertical difference of more than 1 inch in any direction on the traveled way; when there is a vertical difference of more than 3/4 inch between the traveled way and the shoulder that has been sealed; and when there is clear surface failure that can't be fixed by sealing and doesn't need base repair. [26f]

One reason for this can be found in the following levels of maintenance, which set clear standards for maintenance work and the corresponding dollar amounts spent on maintenance:

- 1.** Quality standards, also called maintenance levels, say how a road and its parts should look, work, and be kept in good shape after maintenance.
- 2.** The level of upkeep depends on many factors, including the weather, the amount of traffic, the terrain, the type of surface, the location, and the age of the facility. The level or standard of upkeep is also affected by the type of road (freeway, expressway, or regular road), its characteristics, and the amount of traffic that uses it.
- 3.** Steps of care come in many ways. They could be a written statement or a number. A level can be set by how often maintenance is done or by a set number of checks that must be done in a certain amount of time. A level can be the thing that fills in the gaps, fixes what's broken, or gets rid of what's not wanted.
- 4.** It is understood that any set level or quality of upkeep must be tempered by the knowledge and opinion of the people who are in charge of keeping the state highway system in good shape. These things must be taken into account, according to the purpose of the building being kept[5].

From what has been written, it seems that California is one of only two or three states that fully understands the benefits of treating quality standards explicitly. In their minds, quality levels are the only basic management tool that can be changed to stay within the budget. At any given time, the list of traits that can be maintained stays the same. The other management tools we'll talk about below should always be used to keep the resources needed to reach certain standard levels to a minimum. Knowing that they have to lower quality standards to save money, California has made rules that say when service levels have to be cut to meet budget needs, safety must come first, then looks, and finally investment in the building. To learn more about what would happen if quality levels were lowered, the department made an impact tableau that showed the likely effects that would happen in areas where quality levels could lead to a 10% drop in costs. Table I shows some examples of the results of early analyses.[5]

Even though these estimates of effects aren't based on numbers and are subjective, the structure is there so that objective methods to these analyses can be added once the system has the right data.

Individual state systems that have been created so far don't show that people are generally aware of how important quality standards are, but people are aware of them. As part of its A3T52 Advisory Committee, the Transportation Research Board Task Force met in Colorado in October 1974 to talk about the needs for repair research. That committee's job is to figure out what repair study needs to be done every five years. At that meeting, an outline of what was talked about at two earlier meetings in Homewood, Illinois, and Atlanta, Georgia, was given. This is what was taken from that summary:

It was thought that more study might be needed to figure out the cost-benefit of maintenance tasks and to compare the costs of fixing one problem with those of fixing another. Along with

these efforts, work must also be done to come up with objective standards for upkeep quality. Once models are available, the best way to spend money can be figured out, and the costs of different repair tasks can be compared. There is a good chance that this long-term program will save a lot of money, but it should be used with short-term projects that can give useful results faster. [6]

Another talk at this workshop was given by G. L. Ray from the Louisiana Department of Highways. Quality standards are an important part of the system in that state. The paper talks about how to build quality of service into system standards, different ways to set quality levels, and how to set quality standards using physical measures instead of subjective criteria for as many maintenance tasks as possible[7].

## 2.4. Quantity Standards

Quantity standards, which are also known as frequency standards or job rates, show how many resources are needed each year for each of the planned upkeep tasks so that the desired level of service can be reached. Even in systems that don't have clear quality standards, the quantity standards show how many resources are needed to keep the route at or above the base quality levels that are generally thought to be acceptable. The amount guidelines don't say what kind of maintenance the roads need right now. They generally show the yearly numbers for certain types of roads, different road conditions, pavement age, location, and other factors.

There are three different ways to set quantity standards, or a mix of them:

1. Extrapolation of historical data relative to resource requirements for certain activities.
2. Engineer's judgment.
3. Direct quantifications of quality standards. [8]

As an example of the third way, let's say there is a quality standard for mowing that says plants will be cut down to 5 inches high when they hit 12 inches of growth overall. Using average numbers for how fast this plant grows in a certain area, it is possible to come up with an amount standard that calls for 3 cuts per movable swath mile per year. That's why this step of turning quality standards into resource needs is an important part of making a budget and planning and organizing the job. This method can only be used for a few tasks; the rest are set up based on experience and good judgment.

When there are quality standards, it's important that the number standards are also practical. The quality standards try to find the best solution. A lot of systems that don't have clear quality standards use number standards to change the amount of service. During his yearly visual review, the boss checks to see if the standard level for each task is too low or too high. If, say, the quality level for a certain activity is too low, the number bar for that activity is raised. Using number standards to change the level of service is a totally subjective and critical way to do it. In reality, it's not that different from the way things were done before a maintenance management system was put in place. However, it does bring attention to the issue of true quality levels, which is a good thing.

## 2.5. Performance Standards

A performance standard is an official list of rules for a certain action that (a) describes the work that needs to be done; (b) describes the best ways to do it and the people who should be on the team; and (c) lists the amount of work that should be done or the expected rate of output. This is the standard that is set up to control, direct, and keep an eye on the repair work that is done on the machines. Lower levels of management are given advice on how to reach a satisfactory level of efficiency through performance standards. Defining the best level of performance is not the point of performance guidelines. Instead, the performance norm should show what amount of work is required.

Performance standards have been built into all fifty states' programs. Some people have put a lot of weight on this one part of the system. It is pointed out that all of the early study was focused on making sure that repair tasks were done consistently and effectively. Because of this, this is the area where people felt most aware of their lack of competence. Also, the performance standards of all the systems we looked at were the most consistently well-tuned part of any system. This is because they are the standard that has gotten the most attention.

At the time, there wasn't a lot of information available, so many of the early systems used time-motion studies to set standards for how well they should work. Using methods from industrial engineering, these studies were needed but cost a lot of money. Based on past research and the engineer's knowledge and experience, most of the more recent systems have been able to come up with efficiency standards. There's no problem with this method, as long as the states follow what their own guides say about reviewing and updating the performance standards at least once a year. The main difference between different ways of putting together performance standards is how specifically the standard explains how an action should be done.

For each upkeep task, performance guidelines give us the following information:

- a) The most appropriate crew size
- b) The type and amount of equipment best suited for the work.
- c) How much of each item is needed and what kind it is (number of tons of mix, square yards of surface treatment, etc.).
- d) A list of the steps and methods that need to be used to complete a task. That's where the wide differences in the amount of information between state systems can be found in this part of the standard.
- e) A good guess of how much work is done each day on average, measured in man-hours per unit of production. This number is also shown in terms of how many estimated output units are made by each crew hour. Often, the projected daily output is also given[9].

All of the systems stress how important it is to review performance standards both once a year and on a regular basis. When technology gets better or safety rules change, changes have to be made. Because the feedback system lets management keep an eye on things and make changes as needed, it is possible to see where the standards are lacking. It is possible to try out possible improvements and then compare the results to the current speed level.

In all state systems, performance standards are structured and written in a similar way. However, at least one set of performance standards has been improved in a big way. [10] In one state, what they call "support activities" are no longer part of the success requirements. There are four types of support activities: (1) travel time to and from the job site; (2) haul time, which includes moving materials from one place to another, getting rid of the load, and making the 40-minute trip back to the source of supply, unless this is specifically stated to be part of the performance standard; (3) safety work related to traffic control and warning devices, flagmen, or a sign truck with an operator; and (4) other support activities, which include all other types of delays that last more than 30 crew minutes. This improvement does make more reports necessary, but it also makes it easier for the system to evaluate work methods and crew performance[11].

# III. Types of Maintenance in Manufacturing

---

## 3.1. Introduction

Maintenance should only be done if it improves the system's performance or service life and if those improvements are worth the cost of the maintenance. The word "performance" here refers to all of the ways the system can help you reach your goals. [12]

As was already said, maintenance can make or break a business, especially one that is very valuable, moves quickly, and has a lot of competition. Traditional ways of maintaining things just don't work in today's fast-paced world, and companies that still do them are quickly becoming obsolete.

IoT devices are used in modern maintenance to collect data, and machine learning is used to process that data to make better predictions and ideas that can be put into action. Combined, unplanned downtime can be cut down so much that it's almost nonexistent. This is on top of other benefits like higher happiness among employees, lower chance costs, better customer views, and less waste.

Companies that make things use industrial repair as an official way to make sure their machines and tools work well. There are different kinds of breakdowns and planned repair plans in the process.

Industrial upkeep is very important for guarding big capital expenditures. Its most important job is to make output go smoothly with as few upkeep problems as possible. Not doing enough upkeep has effects on more than just the cost of items that need to be replaced. It also leads to:

- Lower efficiency
- Lower equipment utilization
- Poor quality
- Higher scrap rate
- Increase of waste as a percentage of materials
- Higher labor costs – overtime and rework
- Less ROI for Capex equipment

Maintenance on the plant is also important because it affects many areas that are necessary for production to run smoothly, such as service levels, customer happiness, and employee mood. Properly kept equipment lowers running costs and makes the equipment last longer.

There are different costs to think about when choosing which upkeep approach to use. Maintenance can be very pricey because of the parts, expert work, and other supplies needed for it. There are pros and cons to every approach when it comes to the level of Industrial upkeep and the costs.

## 3.2. Different types of Maintenance

In manufacturing, picking the right repair methods and putting them into action is key to getting the most out of your operations. Because of this, our research goes into detail about each of the following upkeep methods, looking at their differences, benefits, and cost effects in the industrial setting:

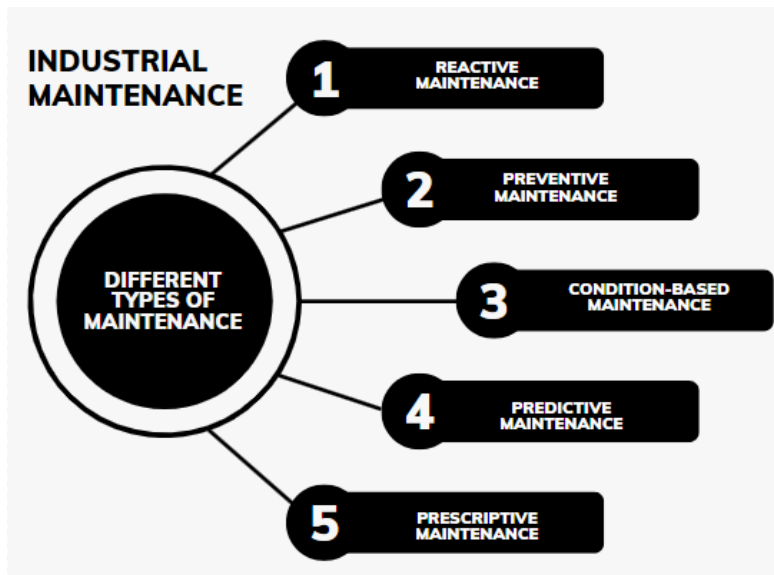

Fig 1. A diagram of different types of maintenance

### 3.2.1 Reactive Maintenance

For most producers, reactive repair is where they start. This is the usual way of maintaining things that has been used in production for a very long time. As the name suggests, this kind of care means being ready for anything that might happen. You might or might not be ready for it or expecting it. When a part breaks, it often actually and figuratively slows down the whole production line. There is then unplanned downtime. People lose their pay. The business loses money. And everyone has to wait until the maintenance expert comes to fix the broken part, which the company might or might not have on hand. This could cause the company to lose a lot of money, have days of downtime, and miss deadlines if the broken tool, machine, or part is expensive or hard to find. Employees are paid to call customers and say, "There's been a delay..." The costs and risks spread throughout the whole supply chain. It's harder and costs more to do reactive maintenance than planned maintenance.

### 3.2.2. Preventive Maintenance

To carry out planned maintenance tasks at times that keep the managed feature's level of service above a level that was previously agreed upon as acceptable. Preventive Maintenance, also called time-based maintenance (TBM) or calendar-based maintenance, is the next step that makers should take when they see that reactive maintenance isn't working.

Parts will be replaced before they break during this type of planned repair, which is set up ahead of time. This is done at a certain time in To carry out planned maintenance tasks at times that keep the managed feature's level of service above a level that was previously agreed upon as acceptable. [8]

Preventive Maintenance, also called time-based maintenance (TBM) or calendar-based maintenance, is the next step that makers should take when they see that reactive maintenance isn't working.

Parts will be replaced before they break during this type of planned repair, which is set up ahead of time. This is always done at the same time, like every 30, 60, or 90 days. Manufacturers can plan for a certain amount of downtime or repair to happen when the factory isn't open. This helps make sure that the machines will be up and running during all planned output times, unless there are problems or things that can't be planned for. "Mean Time Between Failure" (MTBF) is an idea used in preventive maintenance to figure out how often to change parts based on when they have failed in the past. It works best on parts that get used a lot and are likely to get worn down over time.

It can be helpful to do preventative maintenance on machines that are used regularly, have cheap parts that are easy to repair, and have a known rate of wear and tear. In these situations, it's easy,

expected, and works. When combined with other types of maintenance, like forecast or planned maintenance, preventive maintenance can be very helpful. time frame, like every 30, 60, or 90 days. Manufacturers can plan for a certain amount of downtime or repair to happen when the factory isn't open. This helps make sure that the machines will be up and running during all planned output times, unless there are problems or things that can't be planned for. "Mean Time Between Failure" (MTBF) is an idea used in preventive maintenance to figure out how often to change parts based on when they have failed in the past. It works best on parts that get used a lot and are likely to get worn down over time. It can be helpful to do preventative maintenance on machines that are used regularly, have cheap parts that are easy to repair, and have a known rate of wear and tear. In these situations, it's easy, expected, and works. When combined with other types of maintenance, like forecast or planned maintenance, preventive maintenance can be very helpful.

### 3.2.3. Condition-Based Maintenance

Based on Conditions With the date and condition-based maintenance methods, maintenance takes some of the guessing out of figuring out when to do maintenance. This kind of care is like Usage-Based maintenance in a way.

Usage-based maintenance takes into account how the machine is used, makes schedules more realistic, and saves money over time. In the same way that calendar-based maintenance replaces parts at set times, usage-based maintenance does the same thing:

- Replace the loofah every 30 days (calendar-based maintenance)
- Change the car's oil every 5,000 km. (usage-based maintenance)

In the second case, it doesn't matter how long it takes to reach 5,000 km; the oil only needs to be changed when it's lost all of its usefulness, and using it any longer could damage other parts of the car. But with much more frequent checks and a lot more info of all kinds. You only have to do maintenance on something when its quality drops below a certain level. Sensors attached to the tool or machine can take measurements all the time, or measurements can come from less common physical data collection methods, like visual inspection.

When it comes to part costs, condition-based maintenance is better than usage-based, calendar-based, and preemptive maintenance. Condition-based maintenance only changes parts that are likely to break soon, so makers get more use out of their money without the damage and downtime that come from using parts until they break, which is what happens with reactive maintenance.

Monitoring that happens often costs more, whether it's done by a gadget or a person. But these costs are usually balanced out by the money saved from less downtime and longer part and machine life.

Costs can add up for installations that use sensors, especially in harsh working conditions where sensors are likely to be destroyed often. Some sensors may need makers to change their machines in order to work with them, which can void their guarantee. It can also get expensive to teach workers how to check, install, and adjust sensors.

With this method, the time between upkeep tasks is hard to predict since parts are only changed when they break. This makes it harder to make plans for planned breaks ahead of time.

Condition-based maintenance makes parts last longer and protects machines from major breakdowns and unplanned downtime. However, it can be expensive and time-consuming to train workers and use aftermarket sensors, especially if sensors need to be changed often. Unpredictability in schedules can also cause potential costs to rise. When this method is used on machines that need to change parts often and are easy to keep an eye on and fix, it works best. Most of the time, forecast and prescriptive maintenance work much better for producers in the long run.

### 3.2.4. Predictive Maintenance

Predictive upkeep is better than the other choices we talked about because it combines many of the best features of each group. More and more accurately, this method helps makers figure out when maintenance is most likely to be needed.

Artificial intelligence, machine learning, and Internet of Things (IoT) devices are used in predictive maintenance to figure out when failures will happen so that makers can plan for them and repair parts before they cause problems. When it comes to maintenance, the goal of predictive maintenance is to find the "Goldilocks" zone, which means not too often and not too rarely. This keeps you from over-maintaining your car, which can lead to waste, higher risks of human mistake, and higher costs for parts and work. This also stops problems that come with not doing enough repair, like major breakdowns, unexpected downtime, and damage to workers or equipment.

To do this, data is gathered from factory tools that have IoT sensors. This data is then compared to both current and past data, and machine learning is often used to find patterns and predict when something will break.

When manufacturers know when a piece of equipment is most likely to break down, they don't need to keep as many extra parts on hand. Predictive repair methods cut down on downtime and make the best use of resources, giving users the best of both worlds.

Like condition-based maintenance, some IoT monitors used for these tasks can't handle harsh industrial settings with metal fragments, lubricants, corrosive materials, and other things like that. It can get pricey to repair and re-calibrate sensors, especially if they void the guarantee on factory-made equipment. It can also be very expensive to hire data workers to keep an eye on and study sensor data so that you can get useful insights.

### 3.2.5 Prescriptive Maintenance

Prescriptive maintenance is the best way to deal with maintenance problems that are about to happen because it goes one step further than predicted maintenance. With prescribed maintenance, producers can take care of their own maintenance needs without the help of a lot of different experts.

Industrial IoT and machine learning are used in both predictive and prescriptive maintenance. However, prescriptive maintenance also uses case models to help decide what to do. If predictive maintenance says that a tool will break in 30 minutes because of the way it is vibrating right now and data from the past shows that these patterns happen before failure, then prescriptive maintenance will say that lowering the load on that tool by 30% right now could make it last three hours longer. It tells you what to do next so that you can get the most out of your time and tools.



### 3.2.5.1. Maturity state of Prescriptive Maintenance

Multivariate methods are used in a mature maintenance plan, which may mix both predictive and prescriptive maintenance tools. This gives manufacturers the most accurate information they can get right now about when parts will break down in the short, middle, and long run. Plus, it helps to fine-tune processes so that tools and parts last as long as possible and unexpected downtime is avoided. Using artificial intelligence to improve techs' situational awareness and knowledge base, predictive maintenance solutions can help them make fixes more quickly.

Some ways of using prescriptive and predictive maintenance can be fragile and cost a lot of money. Machine Metrics has an industrial IoT platform that can work in a lot of different manufacturing settings, gather data at 10,000 points per second, and send it to data professionals who are ready to help improve things on the factory floor. Because we are experts in advanced digital transformation, we have made our process so easy that our Do-It-Yourself plan lets you put our IoT devices on factory tools without voiding the warranty and without us having to go to the factory at all.

## 3.3. Benefits of Industrial Maintenance

In the US, the machinery repair business grew by 10.4% in 2021. The reason for this is that regular repair can make the processes more stable and dependable. It also has other advantages, such as:

- **Improved uptime:** Are you sick of being interrupted without warning? By reducing unexpected downtime, good industrial repair practices can boost output and efficiency.
- **Minimized waste:** Using too much energy and throwing away too much is a big waste in your business. Industrial upkeep makes sure that your tools work at their best and that you get the most out of your resources.
- **Maximized safety:** There are a lot of rules that businesses need to follow because industrial machinery is often dangerous. Your workers will be safe if you do industrial repair the right way.
- **Reduced costs:** Because industrial gear is often dangerous, companies have to follow a lot of rules. As long as you fix things in the right way, your workers will be safe.

## IV. The Industrial Maintenance System Approach

---

A maintenance management system is a formal procedure used to plan, organize, direct, control, and evaluate maintenance programs and administration. The majority of state highway departments have seen maintenance management systems as the answer to the challenge of providing adequate highway maintenance for an expanding highway system, faced with a limited budget and rising costs.

This chapter's goal is to provide a composite model system that will be representative of the work being done by China state transportation departments, each of which has put its own systems into place.

### 4.1. Objectives of Maintenance Management System

Since there is no one universal system that would be suitable for all states to adopt, each state has created and put into place its own system, frequently with the help of consultants; state systems can include anywhere from few to nearly all of the qualities listed below.

The fundamental components of comprehensive maintenance management systems are as follows:

- Inventory of Highway Features
- Standards of Maintenance
- Performance Allocation
- Procedure Scheduling
- Procedures for Reporting
- Control Techniques
- Methods of Evaluation

All of the above elements, as they presently exist in several state highway agencies, will be discussed below.

### 4.2. Inventory of Highway Features

Most systems have an inventory of the highway elements that are under maintenance. State systems differ widely in how thorough their initial data collection efforts were and how much attention they paid to updating the inventory data on a regular basis. Some systems developed comprehensive inventories early on but never explicitly included them in their system designs; therefore, they are not used in the planning and budgeting phase other than to assist field supervisors in determining their annual workloads.

The surveyed items are summed up in most systems according to the different road categories and maintenance zones.

- The items that are usually included in the inventories are listed as follows:
- Pavements (type; number of lanes; width)
- Shoulders (type; width)
- Slopes (how maintained: mowing; spraying; grading)
- Medians (type; width)
- Slope Protection (retaining wall; rip-rap; cribbing;
- etc.)

- Interchange (type; ramp length)
- Pavement Markings
- Mowable Areas
- Fencing (type)
- Ditches (width; depth; type)
- Guardrail (type)
- Guide Posts
- Bridge Structures (full description)
- Culverts (size; type)
- Drainage Structures (type)
- Curbs and Gutters (type)
- Signs (type)
- Rest Areas (type; description)

Certain other elements found in some inventories are:

- litter barrels;
- impact attenuation devices;
- snow fences;
- light poles;
- electrical devices.

The next paragraphs describe one state's methodology for collecting inventory data: the objective was to compile a record of the quantities of maintainable elements of each highway by route and locations. While some data collection took place in headquarters, the majority of the work was done in each district by field inventory teams, which consisted of three people: a driver, an observer, and a recorder. Two team members were assigned to handle the entire district's inventory, while the third member was the foreman of the highway section that needed to be inventoried. The roles of driver, observer, and recorder were alternated among team members to minimize task fatigue.

The methods adopted for conducting the field survey provided assurance that there would be reasonable statewide uniformity in the resulting inventory data file. Prior to starting the field surveys, each inventory team received instructions at a training session at which a manual of inventory instructions was issued.

The cars were outfitted with odometers reading to the hundredth of a mile; experience of the team quickly determined the most appropriate measuring method; for distances that could not be measured by odometers, such as drainage channels, distance was measured by pacing. It was believed that an inventory team could proceed between 5 and 10 miles per hour in recording data, stopping only when required to obtain information that cannot be seen or measured from the car, such as widths of drainage channels. Due to labor costs and practical concerns about how the data will be used in the end, relatively low accuracy standards were set for the majority of roadway parts.

Practical considerations concerning the ultimate use of the data and the labor costs involved in collecting it led to the establishment of very modest precision requirements for most highway elements.

Significant information about climate, terrain, contiguous land use (i.e., urban, rural), traffic volumes, road age, and other characteristics that could have an impact on maintenance

requirements were listed in the inventory file, which was created in the headquarters office, in addition to the physical quantities included by route and location. [13]

Regression analysis was used to determine the sample size required to achieve a 95% confidence level in the remaining districts. This allowed the highway department to reduce the cost of performing their highway features inventory by approximately 75% while maintaining the levels of accuracy and thoroughness they desired. Pennsylvania, the state with the greatest number of lane miles of maintenance responsibility (94,790 lane miles), used a statistical approach to gather their inventory data. The roads were each assigned a functional use category. Complete inventories of element quantities existing for each category of road were performed in two districts.

### 4.3. Tracking Maintenance History

The historical data of vehicles in China is maintained by various private individuals and organizations (manufacturers, bureau of motor vehicles, certified dealers, insurance brokers, etc.), and each of them only maintains a small portion of the historical data. For instance, repair records and maintenance data are reserved by certified (even uncertified) vehicle mechanic workshops; only certified workshops are required to share their records to the car manufacturer's database; the most valuable data retained by insurance companies are not accessible to the public; additionally, each component of the entire historical data is stored locally and logically disconnected; new buyers cannot browse through all standalone databases dispersed throughout various industries and examine the entire.

In this work, we propose a BCT-based vehicle history tracking service, called BCVehis. It gathers data from various sources and appends these data to the Blockchain, which cannot be either tampered with or manipulated. All participants in the BCVehis ecosystem are capable of appending and accessing data on the Blockchain equivalently. Therefore, BCVehis can provide full transparency of vehicle historical data and foster trust among participants in a used-car transaction. Blockchain technology (BCT) was proposed by Nakamoto in 2008 [15]. It is an emerging technology that is garnering a lot of attention from a variety of fields [16]–[19].

The following is a summary of the main innovative contributions made by the solution suggested in this article: In order to solve the problem of information asymmetry in the used car market and improve transaction transparency throughout the used car trade, a BCT-driven vehicle information sharing model is being proposed.

Putting out a plan for data validation and collecting from several sources to guarantee the accuracy and legitimacy of vehicle histories.

Use smart contracts to automate the processes involved in data sharing, validation, gathering, and querying for vehicle history.

#### 4.3.1. Fundamental Ideas

Blockchain is defined as a data structure, which creates a shared ledger among a peer-to-peer (P2P) network [20]. Cryptography is used to guarantee the security of shared ledger management by each participant in the network, obviating the need for a central intermediary to enforce the rules. The decentralized structure is the most powerful feature of BCT. It is hard to tamper the data when they are appended into a Blockchain. Prior to formally inserting a record into the Blockchain, the submitted records must be verified by peers in the Blockchain network. A typical Blockchain network usually consists of three core components: 1) data block: a list of data added to a ledger over a given period, which usually contains the data size, timestamp, nonce, Merkle root, version, and hash value of previous block; 2) block chain: a chain structure that logically links these data blocks; and 3) P2P network [21]. As a principle mechanism of data consistency, the consensus is the process to negotiate an agreement among a group of peers in a Blockchain network, and consensus algorithm is an essential for transaction verification in a

Blockchain network. Due to the different purposes (value trading, immutable data storing, and etc.), various types of consensus algorithms are developed, such as Ripple [22], PoW [23], PoS [24], DPoS [25], and PBFT [26].

Blockchains are generally divided into permissionless ones and permissioned ones [27]. Actually, permissionless Blockchains usually allow public access, whereas permissioned Blockchains usually restrict access of the consortium members. Governmental and industrial sectors prefer to utilize permissioned Blockchains, since only selected participants can involve in the consensus process. Permissioned Blockchains can be further divided into consortium Blockchains and fully private Blockchains [28], [29]. It is easier to reach the consensus in consortium Blockchains because only trusted participants account for the authority. Each data appending requires the privilege granting from a trusted participant and the underlying protocol is modifiable when the majority of trusted participants reach an agreement. To adapt specific situations and business scenarios, the permission in Blockchains can be further tailored. For example, in partially decentralized Blockchains, the public members are given permission for queries in a limited time. In contrast, the privilege to append data in fully private Blockchains is owned by a single participant whereas the privilege to read is granted to the public.

### 4.3.2. Contract Smart

In the context of BCT, a smart contract is defined as a term-based contract that can be translated into codes and built as a self-executed program. It is intelligent enough that the contract is capable of condition checking, monitoring, and self-enforcing inputs from external trusted parties if they meet the criteria. Users can compile the terms of a contract via programming, which is automatically replicated and self-executed across the nodes in a Blockchain network. Szabo first proposed the idea of a smart contract in 1997 [30]. It is first implemented as a core feature in Ethereum [31].

### 4.3.3. Applications of Blockchain in the Automotive Sector

More automotive-related businesses are using BCT these days [32–36]. Three main goals can be accomplished with BCT in the automotive industry: first, dependable business-related data exchange [37]; second, vehicle-generated data would be monetized by selling unused capacity through ride-sharing services; and third, data held by various organizations (automotive manufacturers, certified dealers, auto finance services, insurance brokers, etc.) across the automotive industry can be linked [36, 37].

Loyyal is a BCT-driven reward ecosystem, which supports redemption of loyalty points to customers and eliminates delays and cost while exchanging information [38]. CarVertical is another BCT-based platform, which can trace and share vehicle information among original equipment manufacturers (OEMs) and external partners in an instant and reliable way [39]. The shared ledger contains basic information of a vehicle, history of ownership, maintenance and repair works, and it would be reviewed and updated by OEMs and other authorized participants. Users are able to settle the payment through smart contracts for services rendered (e.g. repairing a vehicle and purchasing/selling a vehicle). Some researchers attempted to check and verify odometer data by using a built-in-car connector to periodically send vehicle mileage data to its BCT-based logbook [40]. Through this mechanism, the displayed mileage can be verified against the actual mileage stored on a Blockchain to avoid odometer tampering. A BCT-based system by Toyota Research Institute is proposed to enable P2P car sharing (e.g. passage of vehicle and trip payments), which records and executes monetary transactions. The system connects smart vehicles, P2P-vehicle-sharing providers and the terminal customers in an efficient and secure way. Users and car-sharing providers would register on the Blockchain and securely exchange data, such as the vehicle location, rent fee, insurance term, and payment account. At the end of the trip, the system will automatically bill the user and update the travel record [41].

Additionally, Daimler has issued a €100,000,000 bond to verify a BCT-driven clean driving reward solution. This is an exciting attempt to incentivize safe driving through a decentralized mechanism. Kasko2Go is designed to evaluate a driver's habit and yoke to insurance system via Blockchains. Circular previously proposed a BCT-based system to track the emission sources for auto manufacture. To lower costs, this system uses shared ledgers as an interoperable database.

#### 4.4. Following Management Practices

Over time, it's likely that they need to change their industrial maintenance practices. But when they make these changes, they can't spring them on their workers without explanation. Workers are conditioned to do their jobs in a very structured way, and it's hard to break old habits.

Change management is a must for any new industrial maintenance practices. That means offering:

- Ongoing training
- HR support
- A marketing and communications campaign
- Updated software and standard operating procedures

#### 4.5. Overall Equipment Effectiveness (OEE)

Measurement is an essential requirement of continuous improvement processes [26, 27]. One of the measurements that can be used to measure good performance in a factory is Overall Equipment Effectiveness (OEE), which was first written about in 1989 from a book entitled TPM Development Program: Implementing Total Productive Maintenance and updated by Seiichi Nakajima of Japan Institute of Plant Maintenance [25].

The previous study tried to enrich the OEE with statistical analysis, simulation modeling, temporal performance expression model, a didactic approach, Overall Resource Effectiveness (ORE), and Valve Diagnosis System (VDS) [6, 10, 12, 16, 17, 18, 28]. Previous research revealed the linkage of OEE implementation with TPM and LM as the most critical factors [10]. Another study also found that human errors in maintenance have a significant positive relationship with OEE [18]. A simulation study has been conducted to evaluate the effectiveness of the production system using OEE before and after introducing improvement initiatives [12]. A temporal performance expression model and a didactic approach enriched the OEE due to the need for adaptive assistance systems [6, 16]. The impact of the worker, equipment, and raw material onto the manufacturing system is considered while calculating OEE alongside ORE [28]. More specifically, another study tried to improve OEE value by detecting and forecasting gradual increasing valves' faults while making use of the VDS [17].

A number of issues have been addressed with the help of the OEE and various improvement techniques. For example, TPM has been used to reduce idle time in the machining process industry [3, 13, 15]. Cellular layout and Single Minute Exchange of Dies (SMED) have been used in another study to address the availability issue [9]. The Failure Mode and Effects Analysis (FMEA) approach has been used in other research to address downtime and root causes of failures in bottleneck equipment [4].

The OEE may be computed using the following formulae [22]:

$$\text{Availability}(A) = \frac{\text{Loading Time} - \text{Downtime}}{\text{Loading Time}} \times 100. \quad (1)$$

$$\text{Performance}(P) = \frac{\text{Theoretical Cycle Time} \times \text{Processes Amount}}{\text{operating time}} \times 100. \quad (2)$$

$$\text{Quality}(Q) = \frac{\text{Processed Amount} - \text{Defect Amount}}{\text{Processed Amount}} \times 100. \quad (3)$$

$$\text{OEE} = (A)(P)(Q). \quad (4)$$

## 4.6. Monitoring all costs.

Businesses sometimes find it difficult to justify more proactive maintenance solutions, but if they begin monitoring the expenses of reactive maintenance, they will be able to determine just how much this strategy is costing them.

Of course, it's also critical to monitor the cost of preventive maintenance. This way, one can assess which course of action is most cost-effective by comparing proactive maintenance costs to reactive maintenance costs and other industrial maintenance costs. However, this analysis cannot be completed without first tracking all costs.

## 4.7. Tag Assets

Regardless of the size of the business, it needs a way to organize and track all the maintenance it conducts on machines. That's why tagging assets is a very important for proper industrial maintenance.

The company Camcode offers durable barcodes and asset tags, such as facilities management asset tags, that seal the image below the surface, making the tag impenetrable to sunlight, water, dirt, chemicals, and temperatures up to 650 degrees. So companies remove communication barriers and save time by tagging all their assets with durable tags.

## 4.8 Creating Emergency Plans

Emergency planning is by no means a novel idea or philosophy; for decades, communities and businesses have undertaken varying degrees of disaster preparation and emergency planning. Federal, state, and local governments, as well as industry, have a shared responsibility for developing protocols and capabilities for handling hazards resulting from natural or technological causes. Thousands of businesses worldwide experience emergencies on a daily basis, ranging from relatively minor (like a medical emergency that may not affect a business's financial stability) to major (like fires or explosions).

Businesses have for too many years put a tremendous reliance on the local community to handle problems at their facilities. Far too many executives have unrealistic expectations about capability of the local fire, police, and emergency medical services to handle emergencies at their facilities. We watch too many "true-to-life" action dramas on television and at the movies and when a real incident occurs at our facility and the emergency responders arrive, we are shocked that maybe they don't have all the tools and tricks that are depicted on television. Every business in this country must be prepared to handle those types of emergencies that may reasonably be expected to occur. If company is not prepared and are expecting the local fire department or emergency squad to handle the situation without company's assistance, it had better get out the help wanted ads and look for a new employment. The main emphasis of community emergency planning is to protect the community. Community emergency planning initiatives are concerned with life safety, the environment, and property-in that order. Property adjacent to company

facility may have a higher priority than company's, in that a community is trying to minimize the spread of an incident to other properties.

While it is a good idea to comply with regulations and requirements pertaining to emergency planning, it should not be the company's primary motivation. If a company's primary emphasis is regulation compliance, it will write its own plan with that goal in mind. However, if a company writes its own plan with the goal of protecting personnel from harm, then it is generally accepted that an emergency action plan (EAP) is a well-thought-out document that details the who, what, when, how, and where, as well as standard operating procedures for handling emergency situations.

A businessman cannot expect the business to grow and survive if it does not have an effective business plan. The same is true for any business when it comes to emergencies: a businessman cannot expect the business to survive an emergency situation without having an effective emergency action plan (EAP). One of the common causes of business failure is the absence of an effective business plan.

Four essential elements are present in a successful emergency response plan:

- **Evaluation:**

The assessment part ascertains the kinds of risks to which the facility might be exposed as well as the possible degree of danger to personnel and property.

- **Being Ready:**

The systems, procedures, and activities created ahead of time in order to support the facility response program are determined by the readiness component.

- **In response:**

The reaction component chooses what actions to take in order to bring the emergency situation under control.

- **Recuperation:**

The recovery component ascertains what has to be done to get the facility back up and running.



## V. Company description

---

### 5.1 History of The Company

Iclotet is a specialist in the design and manufacture of solutions for industrial process automation. Their long history of more than 70 years and the trust of customers have placed in them throughout this time have made the Iclotet a reliable supplier of reference in different sectors. Their team, made up of qualified professionals in different fields, allows them to offer solutions all over the world, as well as to focus personally on each project; from design to start-up, taking care of the customer during all the phases of the process. Iclotet has some different following spheres and brands:

- Iclopal – Pallet inspection and repair
- Iclomeat – Solutions for the meat industry
- Iclogog – Automatic warehouses ASRS
- Unpandbike – Automatic bike parking

One of the main and large client/partner of Iclotet is CHEP Brambles company. They have grown together for the last 20 years, helping each other with processes throughout Europe, by developing new technologies and by project implementation and support to service centers.

CHEP is the leading company in the field of pallet rental. CHEP pallet rental is based on the concept of sharing and reuse, also known as Pooling. Sharing and reusing pallets contributes to their sustainability: that's why pallets are not for sale. The CHEP pooling system offers to clients the opportunity to rent the necessary equipment which they will collect once used, to make it available again to other customers.

### 5.2. Structure and Working Process of The Machinery

The company which allowed me to do research is Logi-Service. This company collaborates with CHEP by using an industrial machinery which was designed by Iclotet.

The purpose of the machinery is to inspect and repair pallets. It can inspect different pallet dimensions: 60x80, 80x120, 100x120. The machinery has infeed and outfeed, the forklift driver usually puts 3 columns of pallets to inspect and from the outfeed also takes 3 columns of ready units. There are usually 5 workers, 1 for inspection, 3 for repair and 1 engineer who is responsible for the maintenance and the production. The engineer should be always attend for the functionality of the machinery because if there is one sensor or photocell does not work or even it has a dust it will stop the line.

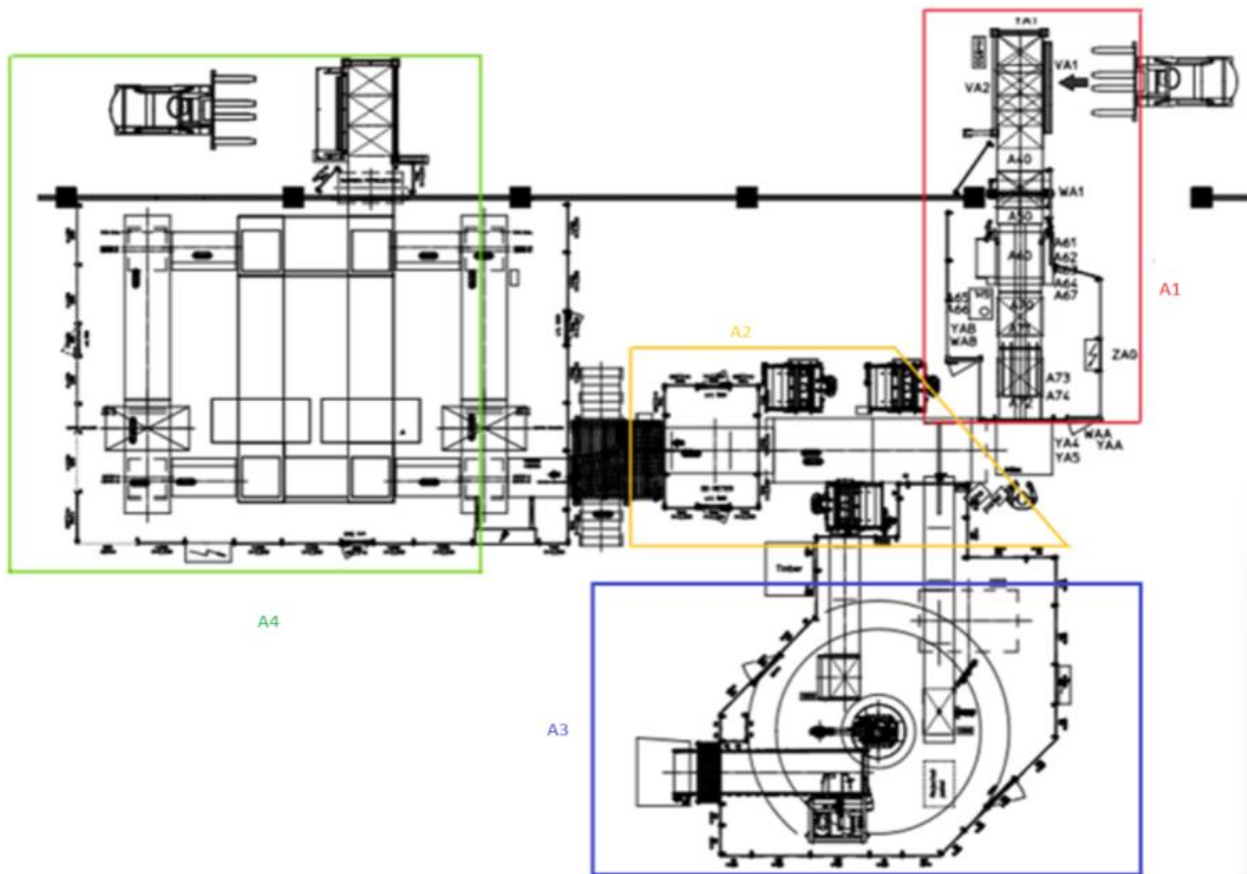

Fig 2. Structure and Working Process of The Machinery

The machinery has following parts:

- Zone A1 Infeed
- Zone A2 Inspection and reparation.
- Zone A3 Robot (Klippa)
- Zone A4 Outfeed, sorting and stacking

### 5.2.1 Zone A1 Infeed

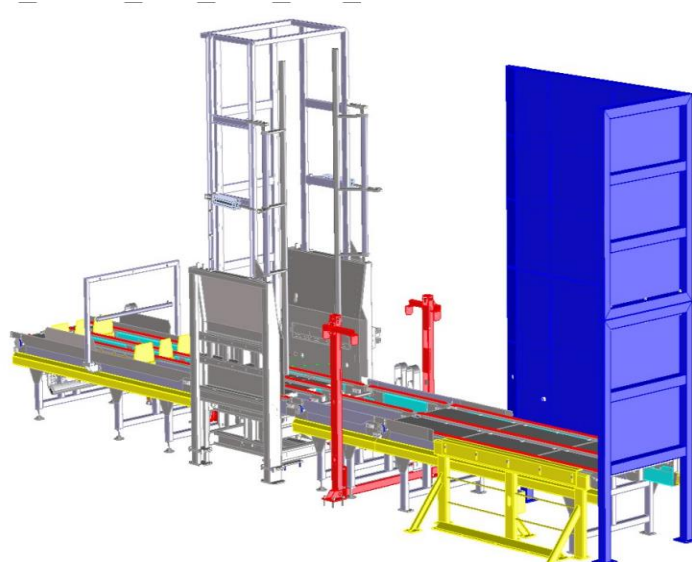
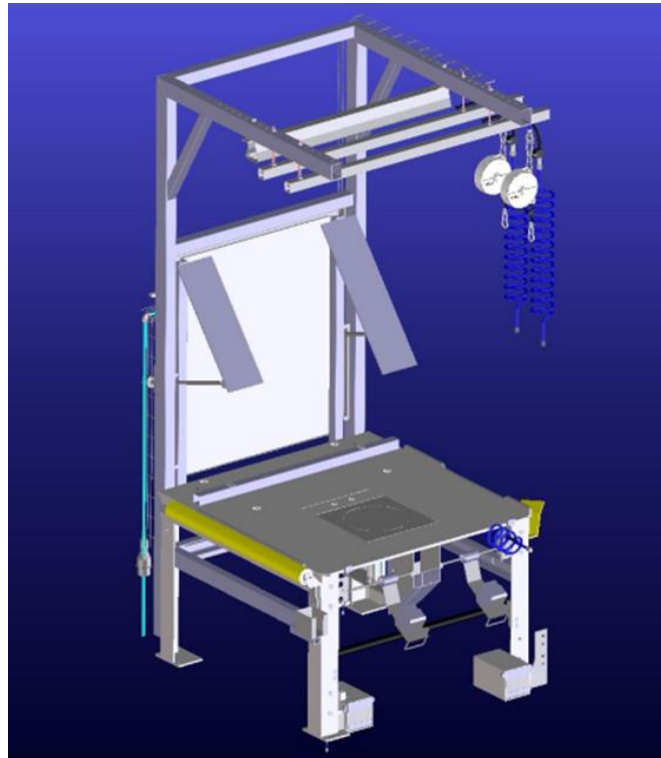

Fig 3. Zone A1 Infeed

The forklift driver theoretically puts 3 columns of units each column has 18 units. Units move automatically inside to the unstacker by chains or by rollers and by signals of the sensors. The unstacker has one platform which lifts up one file of units and there is a fixer which fixes all units and separates them on by one. Then each unit goes to the inspection part, there is a stopper which stops the unit until the inspector allows to move.

### 5.2.2. Zone A2 Inspection and Reparation

In this part of the machinery it has an inspector who has the main role on the production system. Inspector controls the units and separates good units and broken or dirty (any defect out of the PQS Product Quality Standard) units. As it was mentioned before, after stopper the inspector allows by buttons units to move and controls every unit. In this part there are two lines: the main line where good units move on and the repair line (above the main line) for units out of the PQS. In the reparation line there are 3 workers on special repair benches who repair and make units to correspond to the PQS and put them manually into the main line. They all have special buttons which allow them to stop coming units and put the repaired one.



Repair bench

Fig 4. Zone A2 Inspection and reparation.

### 5.2.3 Zone A3 Robot(Klippa)

This line is connected to the main line from inspector side and to the repair bench. In the production the most time consuming part is removing defected parts. That's why the main purpose of the robot is to cut defected parts. It can cut over 400 units in 8 hours. The inspector detects the defected units and orders to the robot which part is defected then sends them to the robot.

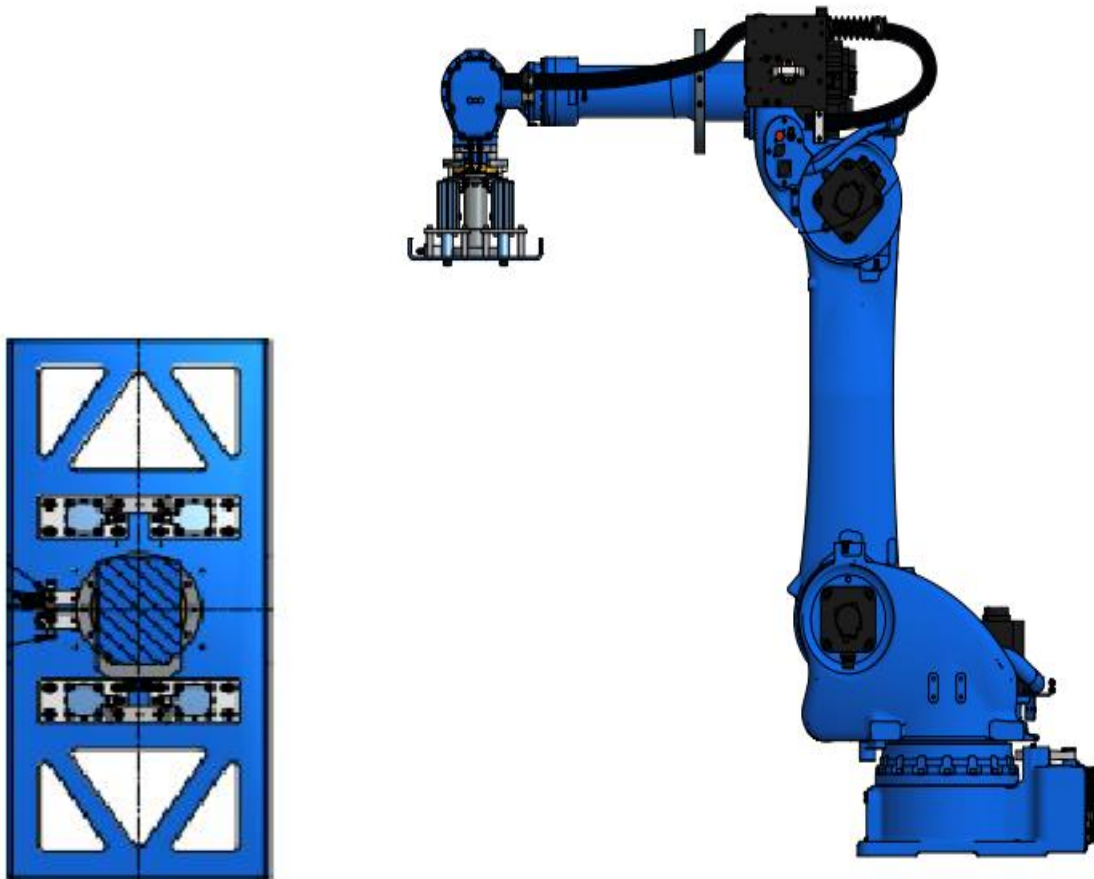

Fig 5. Zone A3 Robot (Klipa)

In the head part of the robot there is Gripper which fixes the unit. The robot takes a defected unit, rotates and puts it in proper position to the blade. After cutting the robot places the unit to the repair line which goes directly to the repair bench.

#### 5.2.4. Zone A4 Outfeed, sorting and stacking

This is the final part of the machinery which begins with humidity sensor. Then the main line is distributed into 4 different quality lines:

- Pc line – Process controlled/reparation line
- Premium line(Units look like new)
- SD line – Surface dry line
- Standard line – units into the PQS

After the humidity sensor all unit go to different lines it depends on their quality. In the start of each line there are stoppers and the platforms which go up and down in order to change the direction of the units.

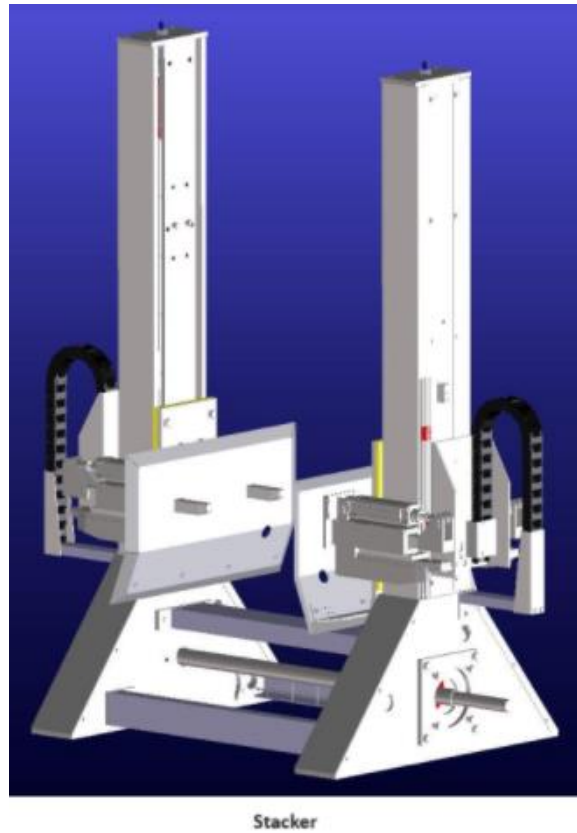

Fig 6. Zone A4 Outfeed, sorting and stacking

Each line has its own fork stacker which stacks one file or 18 units. The ready file goes forward and waits other two files, because the forklift can take 3 files(54 units) in a try.

### 5.3. Operating Mode (Program)

The system is divided into different functional (program) zones. Each of these zones allows different operating modes:

- Automatic mode: Allows autonomous operation of the zone.
- To access this mode you must:
  - Meet all conditions for entering Automatic Mode.
  - Give the order to switch to Automatic Mode by pressing a button manual control / HMI / Scada.
  - Wait a safe amount of time.
- Manual mode: It allows you to carry out machine actions based on the orders received from the operator.
- To access this mode you must:
  - Meet all conditions for entering Manual Mode.
  - Give the order to switch to Manual Mode, by operating a button manual control / HMI / Scada.
- To carry out the actions you must: Introduce the order of the requested action by pressing a command manual/HMI/Scada. (ATTENTION: do not carry out manual actions if you are not knows how the machine works, if you don't have the training and of the authorization for this purpose).
- Freeze Mode: If the zone is neither in automatic nor manual mode, it is in this mode. This way no operation is permitted in the area.

- 

## 5.4. Electric zone and Safety devices

The status in the operation zone indicates whether it is enabled for operation. If the zone receives an error from the safety devices and/or protections, it goes into error. Once the safety/protection devices have been relocated and the necessary conditions have been re-established, the area can return to the OK state, enabled for operation.

The electrical zones are a group of machines powered by the same power supply group. In this way, if one of the safety devices of the aforementioned electrical zone is activated (press mushroom, open door...) this remains without potential, the energy supplies of this electrical area. An electrical zone includes one or more program zones.

Production line safety devices are designed to reduce the risk of these occurring dangers due to the machinery or the product. Under no circumstances should the safety devices installed on the machine be bypassed. Should not be work without safety devices in perfect condition and in perfect working order. Guards and protective devices are used to protect people, eliminating dangers or reducing them sufficiently.

- Depending on their nature they are divided into:

Fixed guards: Such as fixed protections with mobile elements, barriers...

Mobile guards with associated safety function: Doors, safety barriers...

Safety devices with associated safety function: Emergency stops...

- Devices(general emergency stop) that have associated safety functions are:

It can be recognized as it looks like a red mushroom with a yellow circle. When pressed the entire line stops. The status of all zones on the line enters error.

- Local emergency stop:

It can be recognized as a black mushroom. When pressed the entire electrical zone stops. The electrical zone enters an error state.

- Security doors:

The security doors to allow access to the cordoned off areas are equipped with a security device. When the device is activated all electrical zones stop. The electrical zones enter an error state.

- Safety barriers:

Safety barriers are normally used to allow access to the product and prevent that of people in a cordoned off area. When the device is activated all electrical zones stop. The electrical zones enter an error state.

- Location:

To locate safety devices, see plant plan.

## 5.5. General Description of Operation. SCADA / HMI

This system is controlled entirely via FMS. The operating status of each area of the program is displayed on the HMI and yes allows you to enable manual or automatic modes. Movements can also be performed manually for each machine described in C31.

The following information is observed on the HMI:

Program zones:

- Stop (grey) - Indicates stopped area.

- Auto (green) - Indicates that the zone is in Automatic mode.
- Manual (yellow) Indicates that the zone is in Manual mode.
- Auto Ready (flashing green) Indicates that the zone meets the conditions to switch to Automatic Mode.
- Fault (red) The zone is not enabled for operation, the devices must be relocated safety or protections.

Cars:

- Grey, car without alarms.
- Viola, car with alarms.

The alarm concept must be associated with each machine, it can refer to a time excessive use to carry out an action up to a thermal. Errors are not included level of electrical zones such as safety devices.

## 5.6. Safety Instructions for Machinery Use

### 5.6.1. Objective

The purpose is to describe the rules, instructions, and corrective and preventive measures regarding Health and Safety related to the use of the provided plant.

### 5.6.2. Responsibility

This includes the instructions for Occupational Risk Prevention necessary to safely perform the operations for which the provided plant has been designed. The Production Manager of the Work Center and, ultimately, the Contractor at whose premises our product is installed, are responsible for all operations carried out with the latter, as well as for compliance with the manufacturer's instructions. Before using the plant for the first time, workers must read the corresponding instruction manual, as well as these safety regulations. Workers responsible for using work equipment, as well as maintenance workers, are responsible for ensuring that the said equipment is used according to the handling instructions provided by the manufacturer. According to current legislation, it is the responsibility of each worker to ensure their own safety and that of others who may be harmed by their professional activities due to any actions or omissions.

### 5.6.3. Special attention should be given to

Properly using machines, equipment, tools, devices, etc., in accordance with their nature and foreseeable risks, as well as any other means by which activities are carried out. Correctly using the means and protective devices provided by the contractor, based on the instructions received from them. Not disabling existing safety devices and always using them correctly. Immediately informing one's superior and workers responsible for carrying out protection and prevention activities or, if applicable, the prevention service, about any situations that, in one's opinion, may pose, for reasonable reasons, a risk to the safety and health of workers. Failure by workers to comply with the aforementioned obligations regarding risk prevention may be considered work negligence.

## 5.7. Safe Use of The Installation and Description of The Flow

Personnel responsible for commissioning and using the machinery must have read the operating manual provided by the manufacturer, especially the safety instructions, before using it for the first time. The manual should also be consulted in case of doubt or problems during use. The work equipment will be used only by authorized personnel. Work with this installation must be

carried out exclusively by individuals with the necessary and sufficient training for this purpose and equipped with corresponding Personal Protective Equipment (PPE). Training will be provided by the manufacturer, supervisor, or production manager of the center where the provided installation is located. Workers must know exactly where all emergency stops and safety systems are located. In case of any problem or unexpected situation with the work equipment, the worker must immediately report it to the supervisor. In case of absence from the installation for any reason, it will be necessary to follow a safety shutdown procedure so that no one can accidentally start it. The first time the machinery is used, the supervisor must ensure that the workers perform their work correctly on it, in accordance with the instructions for use and safety indications described in this document. For any type of maintenance or repair, whether total or partial, it will be necessary for the installation to be out of service. It is also recommended to indicate or mark such operations and, if possible, remove the safety key or any other similar device so that no one can accidentally start the machinery. If during maintenance or repair work it is necessary to remove protections or safety guards, these must be replaced before completing the work and restarting the machinery. Any modification, improvement, or change that may affect the total or partial safety of the installation or any of its components must be notified and approved before implementation by the Safety and Hygiene Department. To protect the integrity of the worker and prevent potential damage to the installation, it is essential to know and adhere to all instructions provided by the manufacturer before performing any operation on it. All assembly, testing, management, and maintenance operations must be carried out by qualified personnel in compliance with current occupational risk prevention regulations, even if not explicitly stated.

Ignasi Clotet assumes no responsibility in case of modification or addition to the installation that may cause inconveniences and incidents or that may cause bad functions of the same.

#### 5.7.1. Protective Devices

The responsibility for individual or collective protective devices (PPE) related to the use of the provided installation lies with the end customer. It is the responsibility of the end customer, with the assistance of their own or external Occupational Risk Prevention Service (or in association with others), to assess and ultimately determine the necessity, type, and quantity of these devices based on the final installation result, its environment, and the workers potentially affected by its use or proximity.

However, the manufacturer provides the following recommendations:

In some circumstances, it may be necessary for workers or individuals circulating or working in the area affected by the installation to use certain Personal Protective Equipment, such as gloves, footwear, goggles, helmet, etc. If the noise to which the worker is exposed exceeds 85 dB, appropriate hearing protection measures must be adopted. If the noise level is between 80 and 85 dB, the use of such protection is advisable. Workers must wear close-fitting clothing without loose parts.

#### 5.7.2. Commissioning Procedure

For commissioning, the supervisor responsible for the installation will give the relevant permission and, if necessary, the safety key to the worker responsible for operating the equipment.

#### 5.7.3. Preliminary Considerations

The equipment will be without power and with operational safety devices preventing its use. Ensure that no one besides oneself (the worker) is near the machinery or its potentially hazardous parts. Ensure that the machinery is free of work product. Verify that there are no other risks or dangers and that the machinery can be started safely. Prepare the work equipment for its tasks.



Consult the manufacturer's instructions if necessary. Ensure that the product is ready and in the designated location within the work area.

#### 5.7.4. Startup Procedure

Again, ensure that everything is ready to start normal operations. Check the proper functioning of the safety devices that prevented the use of the machinery. Initialize the machine following the instructions in the operating manual. Pay particular attention to its moving parts. Stop the machinery if any circumstances arise that prevent starting work immediately.

#### 5.7.5. Instructions for Safe Work

A basic principle of electricity is known as Ohm's law (Voltage = current  $\times$  resistance). To have the completed circuit necessary for current flow, a closed loop must exist and a voltage source must drive the current through the impedance. To receive a shock, one must contact the electrical circuit at two points, and there must be a voltage source that causes the current to flow through an individual. In electrical terminology, grounding is applied to two separate concepts: the grounding of electrical power and the grounding of electrical equipment. To provide an extra measure of safety from gross electrical shock (macro shock), the power supplied to most operating rooms (ORs) is ungrounded. The line isolation monitor is a device that continuously monitors the integrity of an isolated power system. The ground fault circuit interrupter is a popular device used to prevent individuals from receiving an electrical shock in a grounded power system. An electrically susceptible patient (i.e., one who has a direct, external connection to the heart) may be at risk from very small currents; this is called micro shock. Problems can arise if the electrosurgical return plate is improperly applied to the patient or if the cord connecting the return plate to the electrosurgical unit is damaged or broken.

The machinery should not remain in operation if work with it is not immediately proceeding.

Emergency Stop:

Emergency stops should be used in the following cases:

- If there is a risk to a person.
- If damage to the machinery could occur.
- If there are doubts about the advisability of its use.
- If part of the work product moves to any point on the machinery.
- If a part of the machinery moves irregularly.

Normal Work:

- Never operate the machinery without permission from responsible supervisor.
- Always to respect the machinery.
- Always to use appropriate protective devices.
- Avoid wearing rings, watches, bracelets, or loose-fitting clothing.
- Connect electrical parts only to networks equipped with a differential switch and grounding.
- Electrical parts can be very dangerous. All operations on electronic terminals or similar products require maximum attention and compliance with safety regulations.
- If cable connections are damaged or broken, they must be replaced immediately.

- Always position the product carefully, considering your safety. In particular, never place your hands or other body parts between components that could trap them.
- Always think about your safety and that of others.
- Always check what is happening around you.
- Always check the machinery through control devices.
- Solve problems, provided you have the appropriate training and competence.
- Call the responsible supervisor or maintenance personnel if you cannot personally correct a problem.
- Always ask your responsible supervisor in case of doubt.
- Never allow other people without the permission of your responsible supervisor to stay near the machine or under suspended loads.
- Never climb on moving equipment or stand under it.
- Never get distracted or move quickly around the machine.
- Never disable existing safety devices.
- Never access the interior of the machine without stopping its operation.
- Never attempt to introduce body parts into the machine while it is in operation.
- Never allow other people to stay near the operating machinery without the permission of your responsible supervisor.
- Never try to solve a problem with the machinery in operation.

### 5.7.6. Equipment Shutdown Procedure

The equipment should be stopped as indicated in the operating manual provided by the manufacturer.

- Always stop the equipment immediately after completing the work: Ensure that the system has completed the cycle.
- Ensure that there are no products inside the machinery that could disturb its operation.
- Once the equipment has been stopped according to the manufacturer's instructions, activate the safety systems that prevent accidental use.
- Clean the machinery and the surrounding area, keeping the work area clean and tidy.

### 5.7.7. Procedure in Case of Malfunction

- The worker, during their normal work, should check the proper functioning of the system.
- The worker should activate the emergency stop if any risk is detected.

- Breakdowns or problems other than those resulting from normal operation should be resolved by authorized personnel.
- Unauthorized or untrained individuals should notify the responsible supervisor or maintenance personnel in case of breakdowns or problems.
- Before using any tool to move the machine or any of its parts, ensure that it is in perfect condition and complies with current safety regulations.

### 5.7.8. Signs

It is necessary to respect safety signs.

**WARNING: HAND TRAPPING HAZARD**



Fig 7. Hand Trapping Hazard

Some moving parts of the machine or its accessories can cause hand entrapment or injuries. To avoid the risk of impact, cuts, or minor injuries, follow safety signals and, if necessary, use the most appropriate protective gloves. Remember that gloves may be contraindicated in cases of entrapment risk. In case of entrapment risk, it must be assessed on a case-by-case basis whether or not to use gloves, as they could facilitate entrapment. Never approach hands to moving hazardous areas. Pay particular attention to all moving parts that, due to their configuration, may not have intrusion prevention safety devices.

**WARNING: CLOTHING ENTANGLEMENT HAZARD.**



Fig 8. Moving parts

There may be a risk of becoming entangled in the moving parts of the machinery. Therefore, it may be necessary for personnel clothing to be close-fitting. In this case, do not wear loose or flowing clothing, and if hair is long, it should be tied back.

It is mandatory to use hearing protection if the sound level is above 85 db.



Fig 9. Hearing protection

If the sound level exceeds 85 dB, it is mandatory for workers to use hearing protection. If the noise level is between 80 and 85 dB, their use is still advisable. Below 80 dB, it is not necessary to use protective devices.

Working with safety devices and protections is mandatory.



Fig 10. Safety

The installation is equipped with safety systems such as perimeter barriers, access doors, etc. These must be stopped to prevent accidents in the event of intrusion. It is strictly prohibited for anyone to linger within the safety zone when the machinery is in operation.

It is mandatory to use eye or face protection.



Fig 9. Eye and face protection

In certain circumstances, the projection of fragments or particles may occur, making it mandatory for workers to use more appropriate eye or face protection. Consult your risk prevention service for guidance.



Fig 9. Protection of moving parts

The protections of the moving parts must be perfectly positioned during use of the machinery. Do not disuse or modify devices such as emergency stops, safety switches, etc. The facility has security systems (such as perimeter barriers, access doors, etc.). These will have to be stopped to avoid accidents in the event of an intrusion. It is strictly forbidden for anyone to stay inside the safety area when the machinery is in operation.

It is forbidden to perform any cleaning, lubrication, calibration, repair, etc., on moving parts. if such operations are necessary during movement, take the necessary precautions.



Fig 10. Forbiddance to perform cleaning, lubrication etc., on moving parts

It is forbidden for unauthorized personnel and workers without mandatory personal protective devices to touch or remain within the machine's action radius.



Fig 11. Forbiddance to work without protective devices

There may be areas that are not fully protected, which is why it is prohibited to touch or remain near the respective action radius to prevent potential harm to individuals, such as entrapment, projections, collapses, product falls, etc.

It is forbidden to perform interventions before interrupting electrical power.



Fig 12. Forbiddance to intervete before interruption electrical power

Before opening any connection box or control cabinet, it will be necessary to first disconnect the electricity supply; furthermore, this operation can only be carried out by qualified personnel. There is a risk of suffering an electric shock. Use insulated tools and dielectric protective devices as necessary.

**Startup Procedure:** To safely start the machine, it is necessary first to ensure that no person or foreign object is passing through or within the machine's action radius. Also, perform a visual and responsible inspection of all safety elements and ensure they are operational. Press the Reset button for all safety zones comprising the area to be started. From the control panel and/or startup button, perform a second visual and responsible inspection, and if there is no worker in a hazardous situation, proceed with starting the area. The entire plant can only be started when all individual operating zones have been activated. Some machines, such as robots, may require prior activation individually as an additional safety measure.

**Shutdown Procedure:** To proceed with shutting down the machine, it is necessary to stop all individual zones in an orderly and safe manner. To shut down a single zone, go to the control screen or electrical control panel for that zone and switch the machine to manual mode. When all zones are in manual mode and to ensure the safety of the plant in case of dangerous activation, activate the emergency stop (mushroom type) to ensure its safety and prevent accidental startups.

## VI. Company proposal

---

### 6.1. Regular Analysis and Checks

This chapter describes the detections of various errors and the safety and quality rules of the maintenance. Descriptions for each detail and functionality.

In the world of manufacturing there are some basic maintenance intervention or check to be carried out regularly.

#### 6.1.1. DAILY CHECK

**Residue:** Large quantities of residues that accumulate in mechanical areas cause rubbing and excessive strain which lead to breakages or excessive wear. Do not use compressed air. If this is the case, protect yourself with protective glasses.

**Photocells and sensors:** Optical cleaning of the photocells (dry, clean cloth). To check correct operation and adjustment.

**Heads:** Do not use compressed air guns; if this is the case, protect yourself with protective glasses. Cleaning of the heads, remove residues manually.

#### 6.1.2. WEEKLY CHECK

**Chains:** Check the condition and greasing of the chains. Do not grease excessively: it could compromise the operation. Company recommends: Natural ESTER base (yellow color) viscosity 40° based on the DIN 51757 standard 100MM=S. To check transmission and drive chains carefully. It must be taken into account that the voltage. The optimum of a transmission chain is one that allows a perpendicular movement equal to a maximum of one centimeter. Lower tension deteriorates the chain, while higher tension puts excessive strain on the axles. For drag chains it is advisable to maintain tension in order to prevent the fold of the chain from coming into contact with the conveyor frame. Tension the chains gradually. o If a defect or excessive wear is observed: To be replaced.

**Escapes:** Check for air leaks and repair or replace appropriately.

**Fixing screws:** To check machine fixing screws. In case of recurrence of loosening, it is recommended to change fasteners and use a fastening adhesive.

**Cylinders:** Check cylinder fastening. Check ball joint screws, cylinder fixing hinges, shock absorbers if existing, etc. If a defect or excessive wear is observed: To be replaced.

#### 6.1.3. MONTHLY CHECK

**Cylinders – Silencers:** Clean the air outlet silencers of the valves. It is common for these to build up and slow down movements, compromising the functioning of the line.

**Rigid ball bearings:** Check rigid ball bearings. Observe game, gain weight

**Guides:** Check guide wear. Visual inspection. Observe wear.

**Square base bearings:** Check square base bearings. Observe game, gain weight.

**Oval base bearings:** Check oval base bearings. Observe game, gain weight.

#### 6.1.4. HALF YEARLY CHECK

**Bearing and traction gyrator:** Grease the bearing (-20°C, use lithium-based grease). If there is excessive wear in the drive, replace the crown and pinion.

**Motors/gearmotors:** Motor consumption and motor protection. Check the oil level and condition. (reducer) Electrical connection and wiring. External appearance: fixing, torsion arm, fan cover, terminal cover. Mechanical transmission: bearing, axle, connecting rod. If some equipment or piece has a defect, excessive wear is observed or any issue that can become a problem and possibly stops the production should be replaced.

### 6.1.5. ALARMS

Alarm systems are important assets for plant safety and efficiency in a variety of industries, including power and utility, process and manufacturing, oil and gas, and communications. Especially in the process-based industry, alarm systems collect a huge amount of data in the field that requires operators to take action carefully. However, existing industrial alarm systems suffer from poor performance, mostly with alarm overloading and alarm flooding. Therefore, this problem creates an opportunity to implement machine learning models in order to predict upcoming alarms in the industry. In this way, the operators can take the necessary actions automatically while they are using their capacity for other unpredicted alarms. This study provides an overview of alarm prediction methods used in industrial alarm systems with the context of their classification types. In addition, a comparative analysis was conducted between two state-of-the-art deep learning models, namely Long Short-Term Memory (LSTM) and Transformer, through a benchmarking process. The experimental results of both models were evaluated and contrasted to identify their respective strengths and weaknesses. Moreover, this study identifies research gaps in alarm prediction, which can guide future research for better alarm management systems. Each machine in the plant contains a tag to indicate the status of alarms.

See list of nomenclature of machines is as follows:

MACHINENAME.FLT.Active[0 to 63]. The first element (.FLT.Active[0]) is automatically activated as long as it is one of the 63 remaining alarms activated. The rest of the elements are standard for all machines, which is why for each type of machine, only the corresponding elements will be activated, leaving the rest free.

The activation of alarms depends on the type:

- Serious alarms: Activate immediately
- Mild alarms: They are activated after a period of time

The alarm code table is on the following page.

№	Alarm Message	Counter
1	Alarm Active	Seconds
2	Tipper safety latch	Seconds
3	Tipper Filter Blocked	Seconds
4	In Cycle	Tenth of seconds
5	In Manual	Seconds
6	Operator cycle time exceed	Seconds
7	Isolator Off	Seconds
8	MCB tripped	Seconds
9	Brake MCB tripped	Seconds
10	Inverter tripped	Seconds

11	Over height stack	Seconds
12	Air Pressure low	Seconds
13	General cycle time out	Seconds
14	Infeed nearly empty of stacks	Seconds
15	Infeed empty of stacks	Seconds
16	Outfeed nearly full of stacks	Seconds
17	Outfeed full of stacks	Seconds
18	Transfer fail to Raise	Seconds
19	Pallet Jam	Seconds
20	Forward transfer timeout	Seconds
21	Reverse transfer timeout	Seconds
22	Stop/pusher fail to Raise/extend	Seconds
23	Pusher in unknown position	Seconds
24	Transfer fail to lower	Seconds
25	Stop/pusher fail to lower/retract	Seconds
26	Fail at exit photocell on a Multiple Stack Conveyor	Seconds
27	Two pallets at Tipper	Seconds
28	Entrance roller door closed	Seconds
29	Tipper raise time out	Seconds
30	Tipper lower time out	Seconds
31	Stacker raise time out	Seconds
32	Stacker lower time out	Seconds
33	Stacker fingers in time out	Seconds
34	Stacker fingers out time out	Seconds
35	Noria turn time out	Seconds
36	Pusher time out	Seconds
37	Position with data but no pallet	Seconds
38	Position with pallet but no data	Seconds
39	Position with Photocell signal but no pallet	Seconds
40	Position with different type pallet	Seconds
41	Paint booth failure	Seconds
42	Low paint tank leve	Seconds
43	Stack in bad position at stamp conveyor	Seconds
44	Logo Application failure	Seconds
45	Tampon 1 failure	Seconds



46	Tampon 2 failure	Seconds
47	Tampon 3 failure	Seconds
48	Tampon 4 failure	Seconds
49	Ink Jet Machine failure	Seconds
50	Banding Machine failure	Seconds
51	Stack too wide	Seconds
52	Time control 1	Seconds
53	Time control 2	Seconds
54	Time control 3	Seconds
55	Time control 4	Seconds

## 6.2. Safety Reparation Rules for The Machinery

### 6.2.1. Unstacker with 4 forks

**Description:** Unstacker has the function of unstacking the product.

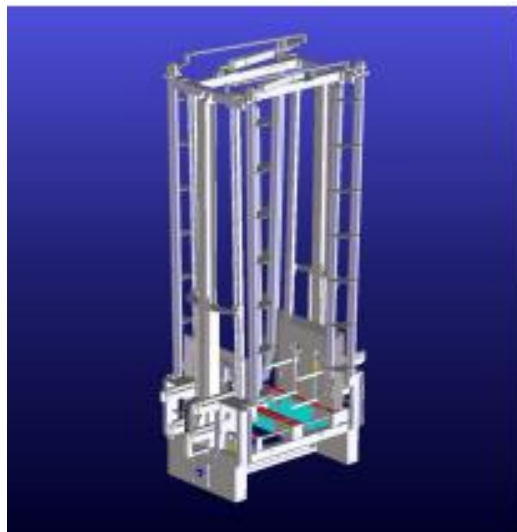

Fig 13. Unstacker with 4 forks

#### 6.2.1.1. Missions of the maintenance technicians

##### **Removing the blockage, always with:**

- Safe stopping of the machine.
- Specialized personnel.
- Adequate protections.
- Pay attention to warnings, dangers and prohibitions.

##### **Maintenance tasks, always with:**

- Check the power outage.

- Safe stopping of the machine.
- Specialized personnel.
- Adequate protections.
- Pay attention to warnings, dangers and prohibitions.

#### *6.2.1.2. Types of risks*

##### **Mechanical risks:**

- Entrapment, dragging or hooking.
- Impact.
- Cutting, shearing or sectioning.
- Projections.
- Crushing.
- Perforation or punching.
- Friction or abrasion.

##### **Electrical risks:**

- Electric contact.

There is a risk of the product falling, mainly during the loading and unloading operation and also when it is transported stacked.

#### *6.2.1.3. Corrective measures (by the manufacturer)*

##### **Protections:**

- Push buttons with emergency stop are installed. The emergency stop function is intended to allow the operator to stop the machine when it is causing an accident, or to stop it when it has to intervene in a dangerous area for a detailed operation.
- Some parts of the machines use electrical voltage. These parts are properly insulated and protected. They are marked to indicate compliance with the regulations in case of risk of electrical contact.
- There are guards that reduce the risk of entrapment in moving elements to a minimum (gears, chains, rollers, belts, etc.).
- Check the power outage.
- Safe stopping of the machine.

- Specialized personnel.
- Adequate protections.
- Pay attention to warnings, dangers and prohibitions.

### 6.2.2. Repair table (without enclosure, unique product)

**Description:** It has the function of facilitating the repair of the product by the worker.

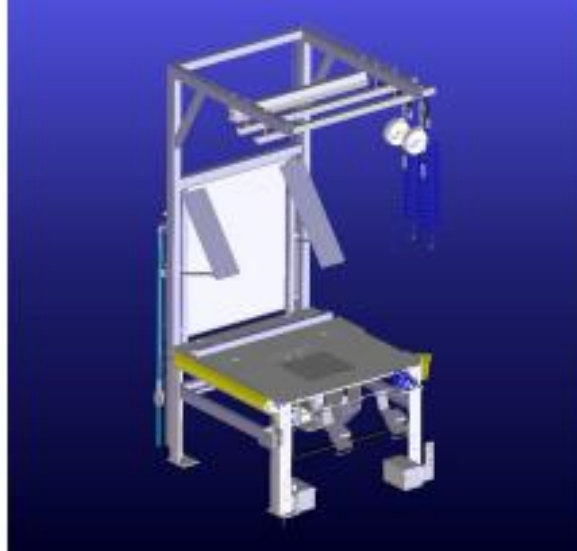

Fig 15. Repair table

#### 5.2.2.1. Missions of the maintenance technicians.

- Check the power outage.
- Safe stopping of the machine.
- Specialized personnel.
- Adequate protections.
- Pay attention to warnings, dangers and prohibitions.

#### 6.2.2.2. Types of risks

##### **Mechanical risks:**

- Entrapment, dragging or hooking.
- Impact.
- Cutting, shearing or sectioning.
- Projections.
- Crushing.
- Perforation or punching.
- Friction or abrasion.

##### **Electrical risks:**

- Electric contact.

##### **Ergonomic risks:**

- Forced postures.

- There is a risk of the product falling, mainly during the loading and unloading operation and also when it is transported stacked.

### 6.2.2.3. Corrective measures (by the manufacturer)

#### Protections:

- Push buttons with emergency stop are installed. The emergency stop function is intended to allow the operator to stop the machine when it is causing an accident, or to stop it when it has to intervene in a dangerous area for a detailed operation.
- Some parts of the machines use electrical voltage. These parts are properly insulated and protected. They are marked to indicate compliance with the regulations in case of risk of electrical contact.
- There are guards that reduce the risk of entrapment in moving elements to a minimum (gears, chains, rollers, belts, etc.).
- Although the implant was designed to minimize ergonomic and postural risks, they do can verify during the working day based on parameters outside of their control of the manufacturer.
- Each tool has protection and a safe place to store it when not in use.
- Electrical connections and cables adapted so that they cannot be cut by tools.

### 6.2.3. Stacker (Fenced, Stack)

**Description:** It has the function of inserting the product forming piles of a specific height.

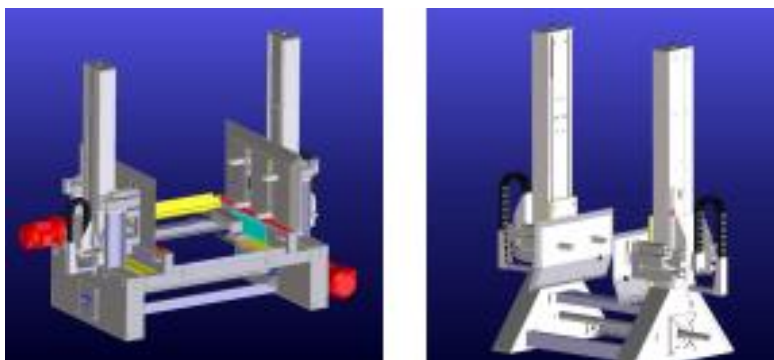

Fig 15. Stacker

#### 6.2.3.1. Missions of the maintenance technicians

##### Removing the blockage, always with:

- Check the power outage.
- Safe stopping of the machine.
- Specialized personnel.
- Adequate protections.
- Pay attention to warnings, dangers and prohibitions.

**Maintenance tasks, always with:**

- Check the power outage.
- Safe stopping of the machine.
- Specialized personnel.
- Adequate protections.
- Pay attention to warnings, dangers and prohibitions.

**6.2.3.2. Types of risks****Mechanical risks:**

- Entrapment, dragging or hooking.
- Impact.
- Cutting, shearing or sectioning.
- Projections.
- Crushing.
- Perforation or punching.
- Friction or abrasion.

**Electrical risks:****Electric contact.**

There is a risk of the product falling, mainly during the loading and unloading operation and also when it is transported stacked.

**6.2.3.3. Corrective measures (by the manufacturer)****Protections:**

- Push buttons with emergency stop are installed. The emergency stop function is intended to allow the operator to stop the machine when it is causing an accident, or to stop it when it has to intervene in a dangerous area for a detailed operation.
- Some parts of the machines use electrical voltage. These parts are properly insulated and protected. They are marked to indicate compliance with the regulations in case of risk of electrical contact.
- There are guards that reduce the risk of entrapment in moving elements to a minimum (gears, chains, rollers, belts, etc.).
- Check the power outage.
- Safe stopping of the machine.
- Specialized personnel.
- Adequate protections.
- Pay attention to warnings, dangers and prohibitions.

## 6.3. Critical Analysis of Maintenance Operations

In this section, we analyze the maintenance operations employed by the company, comparing them with industry standards and practices found in the literature. This analysis aims to identify the strengths and weaknesses of the current operations and propose improvements based on best practices.

### 6.3.1. Comparison with Literature

**Maintenance Strategies.** The company employs a combination of reactive, preventive, and predictive maintenance strategies. According to the literature, reactive maintenance, though sometimes necessary, often leads to higher costs and increased downtime due to its unplanned nature. Preventive maintenance, on the other hand, can be more cost-effective by scheduling repairs before failures occur, thus reducing downtime and extending equipment life. Predictive maintenance, using IoT devices and machine learning, further enhances efficiency by predicting failures and optimizing maintenance schedules based on data-driven insights.

**Overall Equipment Effectiveness (OEE).** The company's use of OEE as a performance metric aligns with the literature's emphasis on its importance for measuring manufacturing efficiency. However, studies suggest that enriching OEE with additional metrics like Overall Resource Effectiveness (ORE) and integrating advanced diagnostic systems can provide a more comprehensive understanding of equipment performance and maintenance needs.

**Cost Monitoring.** Monitoring maintenance costs, both reactive and preventive, is crucial for determining the most cost-effective maintenance strategy. The company's approach to tracking these costs aligns with best practices, yet it could benefit from more detailed cost-benefit analyses to optimize maintenance spending further.

### 6.3.2. Pros and Cons

- **Pros**
  - Structured Maintenance Procedures: The company follows well-defined procedures for maintenance tasks, ensuring safety and consistency.
  - Use of OEE: The adoption of OEE as a performance metric helps in tracking and improving manufacturing efficiency.
  - Emphasis on Safety: Detailed safety measures and protocols are in place to protect maintenance personnel and equipment.
- **Cons**
  - Heavy Reliance on Reactive Maintenance: While necessary in some cases, the frequent use of reactive maintenance can lead to higher costs and unplanned downtime.
  - Limited Integration of Predictive Maintenance: Although predictive maintenance is mentioned, its full potential is not being exploited. Greater integration of IoT and machine learning could significantly enhance maintenance efficiency.

**Insufficient Cost-Benefit Analysis:** More detailed analyses comparing the costs and benefits of different maintenance strategies could help in optimizing the maintenance approach.

The company's maintenance operations have several strengths, particularly in their structured procedures and emphasis on safety. However, there are areas for improvement, especially in reducing reliance on reactive maintenance and integrating advanced predictive maintenance technologies. By comparing these operations with best practices from the literature, we can identify and implement improvements that enhance efficiency and reduce costs, thus achieving the aims of this thesis.



## VII. Conclusions

---

This thesis has critically analyzed the maintenance operations of an industrial machinery company, focusing on the inspection and repair of pallets. The study compared the company's maintenance practices with industry standards and literature, highlighting the strengths and weaknesses of the current approach.

The company's maintenance operations are well-structured and emphasize safety, aligning with best practices in the literature. However, there is a heavy reliance on reactive maintenance, which can lead to higher costs and unplanned downtime. The integration of predictive maintenance technologies, such as IoT and machine learning, is identified as a significant opportunity for enhancing efficiency and reducing costs.

Recommendations for improvement include greater integration of predictive maintenance, more detailed cost-benefit analyses, and optimizing the balance between reactive and preventive maintenance strategies. By implementing these recommendations, the company can improve operational efficiency, reduce maintenance costs, and enhance overall equipment effectiveness.

This work contributes to the field of industrial maintenance by providing a detailed analysis and practical recommendations for improving maintenance practices. Future research could expand on this study by exploring the implementation of the proposed recommendations and assessing their impact on maintenance performance and cost-efficiency.



# References

---

1. Oliver, David C., "The Legal Responsibilities of Maintenance Operatives in the Liability Sector, Highway Research Record Number #347, 1971.
2. Tallamy, Byrd, Tallamy & MacDonald, "A Study of Highway Maintenance Quality in Ohio", Falls Church, Virginia, 1970.
3. Pennsylvania Department of Transportation, Bureau of Maintenance, Harrisbury, Pennsylvania. "Maintenance Management Manual" Draft Copy
4. California Department of Transportation, Division of Highways, Maintenance Branch, Sacramento, California. "Maintenance Management in California", C. E. Forbes, Maintenance Engineer, presented at Western Association of State Highway Officials, June, 1971.
5. Forbes, C. E., "Economics of Maintenance Levels", Highway Research Board Number #347, 1971.
6. Briggs, George, "Program to Develop 5 Year Maintenance Research Needs - Management Area", Discussion Paper prepared for Transportation Research Board Workshop, Lost Vally Ranch, Colorado, October, 1974.
7. Ray, G. L., "Quality of Service to Highway Users: A Review of the State of Knowledge", Louisiana Department of Highways, presented at the Transportation Research Board Workshop, Colorado, October, 1974.
8. "Maintenance of Rural Roads: Principles of a Road Maintenance Management System", Organization for Economic Co-operation and Development, Paris, France, 1973.
9. A South Dakota, Department of Highways, "Maintenance Management System", Pierre, South Dakota
10. Pennsylvania Department of Transportation, Bureau of Maintenance, Harrisbury, Pennsylvania.
11. Pennsylvania Department of Transportation "Foreman Manual" Draft Copy
12. Alexander, J. A., Moavenzadeh, F. "Highway Maintenance", M.I.T., Urban Systems Laboratory, Report TR-70-38, 1970.
13. Nevada Department of Highways, Maintenance Division, Carson City, Nevada: "Maintenance Management System, Manual of Instructions" 1973, "Inventory Instructions", September 1, 1972.
14. Pennsylvania Department of Transportation, Bureau of Maintenance, Harrisbury, Pennsylvania. "History of Maintenance Management Systems.
15. S. Nakamoto, Bitcoin: A Peer-to-Peer Electronic Cash System, Oct. 2008
16. T. M. Fernandez-Carames and P. Fraga-Lamas, "A review on the application of blockchain to the next generation of cybersecure industry 4.0 smart factories", *IEEE Access*, vol. 7, pp. 45201-45218, 2019.
17. G. S. Singh and S. Singh, "A review on the use of block chain for the Internet of Things", *Int. J. Comput. Sci. Eng.*, vol. 7, no. 7, pp. 332-358, Jul. 2019.
18. M. Turkanovic, M. Holbl, K. Kotic, M. Hericko and A. Kamisalic, "EduCTX: A blockchain-based higher education credit platform", *IEEE Access*, vol. 6, pp. 5112-5127, 2018.

19. K. Salah, M. H. U. Rehman, N. Nizamuddin and A. Al-Fuqaha, "Blockchain for AI: Review and open research challenges", *IEEE Access*, vol. 7, pp. 10127-10149, 2019.
20. S. Nakamoto, Bitcoin: A Peer-to-Peer Electronic Cash System, Oct. 2008.
21. D. Schwartz, N. Youngs and A. Britto, The ripple protocol consensus algorithm, 2014.
22. S. Underwood, "Blockchain beyond bitcoin", *Commun. ACM*, vol. 59, no. 11, pp. 15-17, Oct. 2016
23. J. Wang, Z. Cai and J. Yu, "Achieving personalized k-anonymity-based content privacy for autonomous vehicles in CPS", *IEEE Trans. Ind. Informat.*, vol. 16, no. 6, pp. 4242-4251, Jun. 2020.
24. M. Snider, K. Samani and T. Jain, Delegated Proof of Stake: Features Tradeoffs. Multicoins Capital, Mar. 2018
25. A. Bogner, M. Chanson and A. Meeuw, "A decentralised sharing app running a smart contract on the ethereum blockchain", *Proc. 6th Int. Conf. Internet Things (IoT)*, pp. 177-178, 2016
26. T. Mitani and A. Otsuka, "Traceability in permissioned blockchain", *IEEE Access*, vol. 8, pp. 21573-21588, 2020. California Department of Transportation, Division of Highways, Maintenance Branch, Sacramento, California. (a) "Program Definitions for the California Transportation Program", Draft: December, 1973. (b) "Planning Programming Budgeting System for Highway Program", November, 1969. (c) "Planning Programming Budgeting System for Highway Program - Planning Phase", March, 1970. (d) "Key Decision Points by Director's Office in the Planning - Programming - Budgeting System", April, 1971. (e) "Training of Maintenance Personnel". (f)
27. M. Fan and X. Zhang, "Consortium blockchain based data aggregation and regulation mechanism for smart grid", *IEEE Access*, vol. 7, pp. 35929-35940, 2019.
28. J. Wang, Z. Cai and J. Yu, "Achieving personalized k-anonymity-based content privacy for autonomous vehicles in CPS", *IEEE Trans. Ind. Informat.*, vol. 16, no. 6, pp. 4242-4251, Jun. 2020.
29. N. Szabo, The Idea of Smart Contracts, 1997,
30. A. Bogner, M. Chanson and A. Meeuw, "A decentralised sharing app running a smart contract on the ethereum blockchain", *Proc. 6th Int. Conf. Internet Things (IoT)*, pp. 177-178, 2016
31. P. Fraga-Lamas and T. M. Fernandez-Carames, "A review on blockchain technologies for an advanced and cyber-resilient automotive industry", *IEEE Access*, vol. 7, pp. 17578-17598, 2019.
32. A. Dorri, M. Steger, S. S. Kanhere and R. Jurdak, "Blockchain: A distributed solution to automotive security and privacy", *IEEE Commun. Mag.*, vol. 55, no. 12, pp. 119-125, Dec. 2017.
33. T. Reimers, F. Leber and U. Lechner, "Integration of blockchain and Internet of Things in a car supply chain", *Proc. IEEE Int. Conf. Decentralized Appl. Infrastructures (DAPPCON)*, pp. 146-151, Apr. 2019.
34. F. Lamberti, V. Gatteschi, C. Demartini, M. Pelissier, A. Gomez and V. Santamaria, "Blockchains can work for car insurance: Using smart contracts and sensors to provide on-demand coverage", *IEEE Consum. Electron. Mag.*, vol. 7, no. 4, pp. 72-81, Jul. 2018.
35. Z. Cai, X. Zheng and J. Yu, "A differential-private framework for urban traffic flows estimation via taxi companies", *IEEE Trans. Ind. Informat.*, vol. 15, no. 12, pp. 6492-6499, Dec. 2019.

36. S. Zhu, Z. Cai, H. Hu, Y. Li and W. Li, "ZkCrowd: A hybrid blockchain-based crowdsourcing platform", *IEEE Trans. Ind. Informat.*, vol. 16, no. 6, pp. 4196-4205, Jun. 2020.
37. K. Yan, W. Shen, Q. Jin and H. Lu, "Emerging privacy issues and solutions in cyber-enabled sharing services: From multiple perspectives", *IEEE Access*, vol. 7, pp. 26031-26059, 2019.
38. Fernández, J.F.G., Márquez, A.C. (2012). International Standards, Best Practices and Maintenance Management Models as Reference. In: Maintenance Management in Network Utilities.
39. Prometheus Group(December, 2022) Maintenance & Reliability, Master Data
40. ISO 55000:2014. ISO 55001:2014, Asset management — Management systems — Requirements
41. ISO 55002:2014, Asset management — Management systems — Guidelines on the application of ISO 55001
42. ISO13374 (2003) Condition monitoring and diagnostics of machines-data processing, communication and presentation, Part 1. General Guidelines, TC 108/SC 5. International standards for business, Government and Society.
43. [MIMOSA](#) guide, January 29, 2021.
44. ANSI ISO/TC 184/SC 4, Laura Mathew, Fabiola Caragol Rivera(1984).

## Acknowledgements

---

This project has been an incredible educational experience for me, on an For me, this project has been a fantastic learning opportunity on a personal, professional, and intellectual level. Thank you to Giulia Bruno, my thesis supervisor at the Polytechnic University of Turin, for all of your help and advice during this thesis work. I appreciate your strict input on how to navigate and improve the project facilities. You helped me to concentrate on the maintenance organization's key elements that best exemplified the suggested changes.

I also want to thank Logi-Service, and in particular General Director Ahmad Chhourey, for providing me with the chance to work on a manufacturing floor and do research with the maintenance crew.

Andrea Ferraris and Anna Lacerna would like to express their gratitude to the administration for their assistance and for providing the relevant theoretical and practical resources. I like the knowledge they imparted and the way it made the company's position and circumstances clear to me.

Alisher Ruzikulov and Hajar El-Rami, my friends and colleges, I am grateful to for their support and patience throughout this difficult time. They gave me the chance to have a deeper understanding of the electrical and mechanical components of machines.

Each of them served as an important board for my thesis during their various internships. Above all, they served as my support system, guiding me through the challenging circumstances I encountered while conducting my thesis study.