



**Politecnico
di Torino**

Politecnico di Torino

Master's degree in civil engineering

Academic year 2023/2024

Graduation session July 2023

Monitoring activity on Fiorenza node of A4 Highway

Supervisor:
Prof. Gabriele Bertagnoli
Co-supervisor:
Eng. Mario Ferrara

Candidate:
Ilie Caldare

Index

Abstract 9

1. Introduction10

 1.1 Description of the bridges10

 1.1.1 210 bridge 11

 1.1.2 223 bridge 12

 1.1.3 2A2 bridge13

 1.1.4 233 bridge14

 1.1.5 2B4 bridge15

 1.1.6 243 bridge16

 1.2 Description of the monitoring system 17

 1.3 Description of the acquisition mode 18

2. Scheduled acquisitions processing21

 2.1 Introduction21

3. Bridge 2A2 deck 422

 3.1 2A2 SP4 L/2 Sensor 3099D23

 3.1.1 Vertical direction (x)26

 3.1.2 Longitudinal direction (y)26

 3.1.3 Transverse direction (z)26

 3.2 2A2 SP4 L/4 Sensor 30EB427

 3.2.1 Vertical direction (x)29

 3.2.2 Longitudinal direction (y)30

 3.2.3 Transverse direction (z)30

 3.3 2A2 SP4 L/8 Sensor 3163930

 3.3.1 Vertical direction (x)33

 3.3.2 Longitudinal direction (y)33

 3.3.3 Transverse direction (z)34

 3.4 2A2 SP4 Pier Sensor 30D4134

 3.4.1 Vertical direction (x)37

 3.4.2 Longitudinal direction (y)37

 3.4.3 Transverse direction (z)38

4. Bridge 2A2 deck 539

 4.1 2A2 SP5 L/2 Sensor 2B7E440

 4.1.1 Vertical direction (x)43

 4.1.2 Longitudinal direction (y)43

 4.1.3 Transverse direction (z)43

 4.2 2A2 SP5 L/4 Sensor 3187F44

Monitoring activity on Fiorenza Node of A4 Highway

4.2.1	Vertical direction (x)	46
4.2.2	Longitudinal direction (y)	47
4.2.3	Transverse direction (z)	47
4.3	2A2 SP5 L/8 Sensor 2B988	47
4.3.1	Vertical direction (x)	50
4.3.2	Longitudinal direction (y)	50
4.3.3	Transverse direction (z)	51
4.4	2A2 SP5 Pier Sensor 2C1E4	51
4.4.1	Vertical direction (x)	54
4.4.2	Longitudinal direction (y)	54
4.4.3	Transverse direction (z)	55
5.	Bridge 223 deck 2	56
5.1	223 SP2 L/2 Sensor 2BE0F	57
5.1.1	Vertical direction (x)	60
5.1.2	Longitudinal direction (y)	61
5.1.3	Transverse direction (z)	61
5.2	223 SP2 L/4 Sensor 2BA63	61
5.2.1	Vertical direction (x)	64
5.2.2	Longitudinal direction (y)	64
5.2.3	Transverse direction (z)	65
5.3	223 SP2 L/8 Sensor 31205	65
5.3.1	Vertical direction (x)	68
5.3.2	Longitudinal direction (y)	68
5.3.3	Transverse direction (z)	68
5.4	223 SP2 West pier Sensor 319BC	69
5.4.1	Vertical direction (x)	71
5.4.2	Longitudinal direction (y)	72
5.4.3	Transverse direction (z)	72
5.5	223 SP2 East pier Sensor 319E3	72
5.5.1	Vertical direction (x)	75
5.5.2	Longitudinal direction (y)	75
5.5.3	Transverse direction (z)	76
6.	Bridge 223 deck 6	80
6.1	223 SP6 L/2 Sensor 2B5E7	81
6.1.1	Vertical direction (x)	84
6.1.2	Longitudinal direction (y)	84
6.1.3	Transverse direction (z)	85

6.2	223 SP6 L/4 Sensor 2BCF9	85
6.2.1	Vertical direction (x)	88
6.2.2	Longitudinal direction (y)	88
6.2.3	Transverse direction (z)	88
6.3	223 SP6 L/8 Sensor 2BCAF	89
6.3.1	Vertical direction (x)	91
6.3.2	Longitudinal direction (y)	92
6.3.3	Transverse direction (z)	92
7.	SAP model	93
7.1	Definition of SAP model – 2A2 bridge	95
7.2	Definition of SAP model – 223 bridge	103
7.3	Results of Model A	107
7.4	Results of Model B	108
8.	OMA Identification	111
8.1	Description of the framework	115
8.2	Decks 4 and 5 of bridge 2A2	116
8.3	Deck 2 of bridge 223	120
8.4	Deck 6 of bridge 223	124
9.	Conclusion	128
	Bibliography	135
	Acknowledgements	136
	Annex 13	137

Index of figures

Figure 1-1: Location of monitored bridges 10

Figure 1-2: 210 - longitudinal section 11

Figure 1-3: 210 - plan 11

Figure 1-4: 210 - half of the transverse section 11

Figure 1-5: 223 - longitudinal section 12

Figure 1-6: 223 - plan 12

Figure 1-7: 223 - transverse section 12

Figure 1-8: 2A2 - longitudinal section 13

Figure 1-9: 2A2 - plan 13

Figure 1-10: 2A2 - transverse section 13

Figure 1-11: 233 - longitudinal section 14

Figure 1-12: 233 – plan 14

Figure 1-13: 233 - transverse section 14

Figure 1-14: 2B4 - longitudinal view 15

Figure 1-15: 2B4 – plan 15

Figure 1-16: 2B4 - transverse section 15

Figure 1-17: 243 - longitudinal section 16

Figure 1-18: 243 - plan 16

Figure 1-19: 243 - transverse section 16

Figure 1-20: Type of accelerometer 17

Figure 1-21: Accelerogram in vertical (x) direction 18

Figure 1-22: Accelerogram in longitudinal (y) direction 18

Figure 1-23: Accelerogram in transversal (z) direction 19

Figure 1-24: Accelerogram in vertical (x) direction 19

Figure 1-25: Accelerogram in longitudinal (y) direction 20

Figure 1-26: Accelerogram in transversal (z) direction 20

Figure 3-1 Deck 4 of 2A2 bridge 22

Figure 3-2 Sensor positions on deck 4 and 5 of 2A2 bridge 22

Figure 3-3: 2A2-S4-L/2 - Natural frequencies obtained in vertical direction 26

Figure 3-4: 2A2-S4-L/2 - Natural frequencies obtained in longitudinal direction 26

Figure 3-5: 2A2-S4-L/2 - Natural frequencies obtained in transverse direction 26

Figure 3-6: 2A2-S4-L/4 - Natural frequencies obtained in vertical direction 29

Figure 3-7: 2A2-S4-L/4 - Natural frequencies obtained in longitudinal direction 30

Figure 3-8: 2A2-S4-L/4 - Natural frequencies obtained in transverse direction 30

Figure 3-9 : 2A2-S4-L/8 - Natural frequencies obtained in vertical direction 33

Figure 3-10: 2A2-S4-L/8 - Natural frequencies obtained in longitudinal direction 33

Figure 3-11: 2A2-S4-L/8 - Natural frequencies obtained in transverse direction 34

Figure 3-12: 2A2-S4-P5N - Natural frequencies obtained in vertical direction 37

Figure 3-13 : 2A2-S4-P5N - Natural frequencies obtained in longitudinal direction 37

Figure 3-14 : 2A2-S4-P5N - Natural frequencies obtained in transverse direction 38

Figure 4-1 Deck 5 of 2A2 bridge 39

Figure 4-2 Sensor positions on deck 4 and 5 of 2A2 bridge 39

Figure 4-3: 2A2-S5-L/2 - Natural frequencies obtained in vertical direction 43

Figure 4-4: 2A2-S5-L/2 - Natural frequencies obtained in longitudinal direction 43

Figure 4-5: 2A2-S5-L/2 - Natural frequencies obtained in transverse direction 43

Figure 4-6: 2A2-S5-L/4 - Natural frequencies obtained in vertical direction 46

Figure 4-7: 2A2-S5-L/4 - Natural frequencies obtained in longitudinal direction 47

Figure 4-8: 2A2-S5-L/4 - Natural frequencies obtained in transverse direction 47

Figure 4-9: 2A2-S5-L/8 - Natural frequencies obtained in vertical direction	50
Figure 4-10: 2A2-S5-L/8 - Natural frequencies obtained in longitudinal direction	50
Figure 4-11: 2A2-S5-L/8 - Natural frequencies obtained in transverse direction	51
Figure 4-12: 2A2- P5S - Natural frequencies obtained in vertical direction	54
Figure 4-13: 2A2- P5S - Natural frequencies obtained in longitudinal direction	54
Figure 4-14: 2A2- P5S - Natural frequencies obtained in transverse direction	55
Figure 5-1: Deck 2 of 223 bridge	56
Figure 5-2: Sensor position on deck 2 of 223 bridge	57
Figure 5-3: 223- S2 – L/2 - Natural frequencies obtained in vertical direction	60
Figure 5-4: 223- S2 – L/2 - Natural frequencies obtained in longitudinal direction	61
Figure 5-5: 223- S2 - L/2 - Natural frequencies obtained in transverse direction	61
Figure 5-6: 223- S2 – L/4 - Natural frequencies obtained in vertical direction	64
Figure 5-7: 223 – S2 – L/4 - Natural frequencies obtained in longitudinal direction	64
Figure 5-8: 223- S2 - L/4 - Natural frequencies obtained in transverse direction	65
Figure 5-9: 223 – S2 – L/8 - Natural frequencies obtained in vertical direction	68
Figure 5-10: 223 – S2 – L/8 - Natural frequencies obtained in longitudinal direction	68
Figure 5-11: 223- S2 - L/8 - Natural frequencies obtained in transverse direction	68
Figure 5-12: 223 – P2W - Natural frequencies obtained in vertical direction	71
Figure 5-13: 223 – P2W - Natural frequencies obtained in longitudinal direction	72
Figure 5-14: 223 - P2W - Natural frequencies obtained in transverse direction	72
Figure 5-15: 223- P2E - Natural frequencies obtained in vertical direction	75
Figure 5-16: 223- P2E - Natural frequencies obtained in longitudinal direction	75
Figure 5-17: 223 - P2E - Natural frequencies obtained in transverse direction	76
Figure 5-18: P2E – Field photography	79
Figure 5-19: P2E – Field photography	79
Figure 6-1: Deck 6 of 223 bridge	80
Figure 6-2: Sensor position on deck 6 of 223 bridge	81
Figure 6-3: 223- S6 – L/2 - Natural frequencies obtained in vertical direction	84
Figure 6-4: 223- S6 – L/2 - Natural frequencies obtained in longitudinal direction	84
Figure 6-5: 223- S6 - L/2 - Natural frequencies obtained in transverse direction	85
Figure 6-6: 223- S6 – L/4 - Natural frequencies obtained in vertical direction	88
Figure 6-7: 223- S6 – L/4 - Natural frequencies obtained in longitudinal direction	88
Figure 6-8: 223- S6 - L/4 - Natural frequencies obtained in transverse direction	88
Figure 6-9: 223- S6 – L/8 - Natural frequencies obtained in vertical direction	91
Figure 6-10: 223- S6 – L/8 - Natural frequencies obtained in longitudinal direction	92
Figure 6-11: 223- S6 - L/8 - Natural frequencies obtained in transverse direction	92
Figure 7-1: Global model of structures 2A2 and 233	94
Figure 7-2: Detail of the model of structure 2A2.	94
Figure 7-3: Detail of the model of structure 233	95
Figure 7-4: 2A2 Transverse section	95
Figure 7-5: Longitudinal beam	96
Figure 7-6: 2A2 horizontal section of the spread footing - Type A	98
Figure 7-7: 2A2 vertical section of the spread footing - Type A	99
Figure 7-8: 2A2 horizontal section of the spread footing - Type B	99
Figure 7-9: 2A2 vertical section of the spread footing - Type B	100
Figure 7-10: Longitudinal beam - pile connection	100
Figure 7-11: Longitudinal beam - pile connection	101
Figure 7-12: Slider connection	102
Figure 7-13: Abutment - direction Turin	102
Figure 7-14: 223 - Transverse section	103

Figure 7-15: 223 Spread footing - type 1	104
Figure 7-16: 223 vertical section of the spread footings – type 2	105
Figure 7-17: 223 horizontal section of the spread footing - type 2.....	105
Figure 7-18: 223 abutment - transverse section	106
Figure 7-19: 223 abutment - longitudinal section.....	106
Figure 7-20: Example of local mode of model A.....	107
Figure 7-21: Example of local mode of model A.....	107
Figure 7-22: Example of local mode of model A.....	107
Figure 7-23: Example of local mode of model A.....	108
Figure 7-24: Example of local mode of model A.....	108
Figure 7-25: Vertical mode of the decks of structure 223 model A.....	108
Figure 7-26: Vertical mode of the decks of structure 2A2 model A.	108
Figure 7-27: Example of global mode of model B.....	109
Figure 7-28: Example of global mode of model B.....	109
Figure 7-29: Vertical mode of the decks of structure 223 model B.....	109
Figure 7-30: Vertical mode of the decks of structure 223 model B.....	109
Figure 7-31: Vertical mode of the decks of structure 2A2 model B.	110
Figure 7-32: Vertical mode of the decks of structure 2A2 model B.	110
Figure 8-1: Examples of stabilization diagram. (a) January, deck 6 of opera 223. (b) March, deck 6 of opera 223.	115
Figure 8-2: 2A2 - Identified frequencies for set 1	116
Figure 8-3: 2A2 - Identified frequencies for set 2.....	117
Figure 8-4: 2A2 - Identified frequencies for set 3.....	117
Figure 8-5: 2A2 - Identified frequencies for the merge of the sets.....	118
Figure 8-6: 2A2 - Modal shape of the identified modes.....	119
Figure 8-7: 223 deck 2 - Identified frequencies for set 1	120
Figure 8-8: 223 deck 2 - Identified frequencies for set 2	121
Figure 8-9: 223 deck 2 - Identified frequencies for set 3.	121
Figure 8-10: 223 deck 2 - Identified frequencies for the merge of the sets.....	122
Figure 8-11: 223 deck 2 - Modal shape of the identified modes.....	123
Figure 8-12: 223 deck 6 - Identified frequencies for set 1.....	124
Figure 8-13: 223 deck 6 - Identified frequencies for set 2.....	125
Figure 8-14: 223 deck 6 - Identified frequencies for set 3.....	125
Figure 8-15: 223 deck 6 - Identified frequencies for the merge of the sets.....	126
Figure 8-16: 223 deck 6 - Modal shape of the identified modes.....	127
Figure 9-1: 2A2 deck 4 and deck 5 - Modal shape identified with the OMA – Top and Side view.....	128
Figure 9-2: 2A2 deck 4 and deck 5 - Modal shape identified with the FEA – Top view – 4.39Hz.....	129
Figure 9-3: 2A2 deck 4 and deck 5 - Modal shape identified with the FEA – Side view – 4.39Hz.....	129
Figure 9-4: 223 deck 2 - Modal shape identified with the OMA – Top and Side view.....	129
Figure 9-5: 223 deck 2 - Modal shape identified with the FEA – Top view – 2.50Hz.....	129
Figure 9-6: 223 deck 2 - Modal shape identified with the FEA – side view – 2.50Hz.....	130
Figure 9-7: 223 deck 2 - Modal shape identified with the OMA – Top and Side view.....	130
Figure 9-8: 223 deck 2 - Modal shape identified with the FEA – Top view – 2.68Hz.....	130
Figure 9-9: 223 deck 2 - Modal shape identified with the FEA – Side view – 2.68Hz.....	131
Figure 9-10: 223 deck 2 - Modal shape identified with the OMA – Top and Side view.....	131
Figure 9-11: 223 deck 2 - Modal shape identified with the FEA – Top view – 4.73Hz.....	131
Figure 9-12: 223 deck 2 - Modal shape identified with the FEA – Side view – 4.73Hz.....	132
Figure 9-13: 223 deck 6 - Modal shape identified with the OMA – Top and Side view.....	132
Figure 9-14: 223 deck 6 - Modal shape identified with the FEA – Top view – 2.68Hz.....	132
Figure 9-15: 223 deck 6 - Modal shape identified with the FEA – Side view – 2.68Hz.....	133

Figure 9-16: 223 deck 6 - Modal shape identified with the OMA – Top and Side view 133
 Figure 9-17: 223 deck 6 - Modal shape identified with the FEA – Top view – 4.40Hz..... 133
 Figure 9-18: 223 deck 6 - Modal shape identified with the FEA – Side view – 4.40Hz. 134

Index of tables

Table 3-1 2023 Average natural frequencies [Hz] identified for 2A2 deck 423
 Table 3-2 2023 natural frequencies [Hz] identified for sensor 3099D – 2A2 SP4 L/223
 Table 3-3 2023 natural frequencies [Hz] identified for sensor 30EB4 – 2A2 SP4 L/427
 Table 3-4 2023 natural frequencies [Hz] identified for sensor 31639 – 2A2 SP4 L/8.....30
 Table 3-5 2023 natural frequencies [Hz] identified for sensor 30D41 – 2A2 SP4 Pier34
 Table 4-1 2023 Average natural frequencies [Hz] identified for 2A2 deck 540
 Table 4-2 2023 natural frequencies [Hz] identified for sensor 2B7E4 – 2A2 SP5 L/240
 Table 4-3 2023 natural frequencies [Hz] identified for sensor 3187F – 2A2 SP5 L/4.....44
 Table 4-4 2023 natural frequencies [Hz] identified for sensor 2B988 – 2A2 SP5 L/8.....47
 Table 4-5 2023 natural frequencies [Hz] identified for sensor 2C1E4 – 2A2 SP5 Pier51
 Table 5-1 2023 Average natural frequencies [Hz] identified for 223 deck 257
 Table 5-2 2023 natural frequencies [Hz] identified for sensor 2BE0F – 223 SP2 L/2.....58
 Table 5-3 2023 natural frequencies [Hz] identified for sensor 2BA63 – 223 SP2 L/4.....61
 Table 5-4 2023 natural frequencies [Hz] identified for sensor 31205 – 223 SP2 L/865
 Table 5-5 2023 natural frequencies [Hz] identified for sensor 319BC – 223 SP2 West pier69
 Table 5-6 2023 natural frequencies [Hz] identified for sensor 319E3 – 223 SP2 East pier72
 Table 5-7: Frequency anomalies for sensor 319E3 – bridge 223 – Sp2 – P2E.....76
 Table 6-1 2023 Average natural frequencies [Hz] identified for 223 deck 681
 Table 6-2 2023 natural frequencies [Hz] identified for sensor 2B5E7 – 223 SP6 L/2.....81
 Table 6-3 2023 natural frequencies [Hz] identified for sensor 2BCF9 – 223 SP6 L/485
 Table 6-4 2023 natural frequencies [Hz] identified for sensor 2BCAF – 223 SP6 L/889
 Table 7-1: IPE properties96
 Table 7-2: Longitudinal beam section97
 Table 7-3: Variable section longitudinal beams properties97
 Table 7-4: 2A2 height piles98
 Table 7-5: 223 deck span103
 Table 7-6: 223 height piles104
 Table 8-1 2023 First three most energetic accelerograms for span 4 and 5 of bridge 2A2 in 2023.....116
 Table 8-2 2023 First three most energetic accelerograms for span 2 of bridge 223 in 2023120
 Table 8-3 2023 First three most energetic accelerograms for span 6 of bridge 223 in 2023124
 Table 9-1 2023 Obtained results128

Abstract

The purpose of this dissertation is the definition of the relevance of the monitoring process on the infrastructures present in Italy. This permit to monitor the changes present in some structural elements or in the overall structure. Firstly, the proper natural frequencies of the structure that have been defined from the acquisition process of the acceleration in the three main directions will be presented. These acquisitions are made by accelerometer which have been installed on the bridge in different points of its span. The acquisition made by them are not continuous, but they are made at a specific time interval. After, a FEM of the overall structure have been made. For this model, the modal analysis has been performed. So, the proper natural frequencies have been defined in the vertical, longitudinal and transverse direction. Sometimes, the Finite Element model is difficult to be defined. This could happen in the cases where the drawings of the analyzed structures are not fully defined or when they have been lost. So, another typology of analysis will be developed. Is the Operational Modal Analysis, which permit to define the modal parameters of the structure. This type of analysis is an output-only method, that means that for performing the analysis, only the response of the structure is need, and not the input forces. Finally, the different obtained frequencies with these three procedures will be compared, in order to understand if this type of monitoring process can be or not efficient. So, in this way it will be possible to establish if even with a lower budget, the monitoring process can give an efficient response.

1. Introduction

1.1 Description of the bridges

A set of 6 bridges are monitored using triaxial accelerometers. These bridges are part of an interchange, called “Fiorenza”, situated near Milan city.

In the next figure are represented the bridges subjected to the monitoring process.



Figure 1-1: Location of monitored bridges

The 6 structures are called:

- 04020002A2 (green) called **2A2**;
- 0402000223 (red) called **223**;
- 0402000210 (yellow) called **210**;
- 0402000233 (blue) called **233**;
- 04020002B4 (orange) called **2B4**;
- 0402000243 (violet) called **243**.

These structures, like the most infrastructure present in Italy, date back to the 60's, so they need to be monitored to have a safe usability.

1.1.1 210 bridge

The 210 bridge is part of the A4 motorway Turin – Trieste. It is composed of 6 decks characterized by a variable length between 24.40m and 30.50m (see Figure 1-2). Its transversal width is equal to 17.10m (see Figure 1-4). The total length is equal to 161.60m.

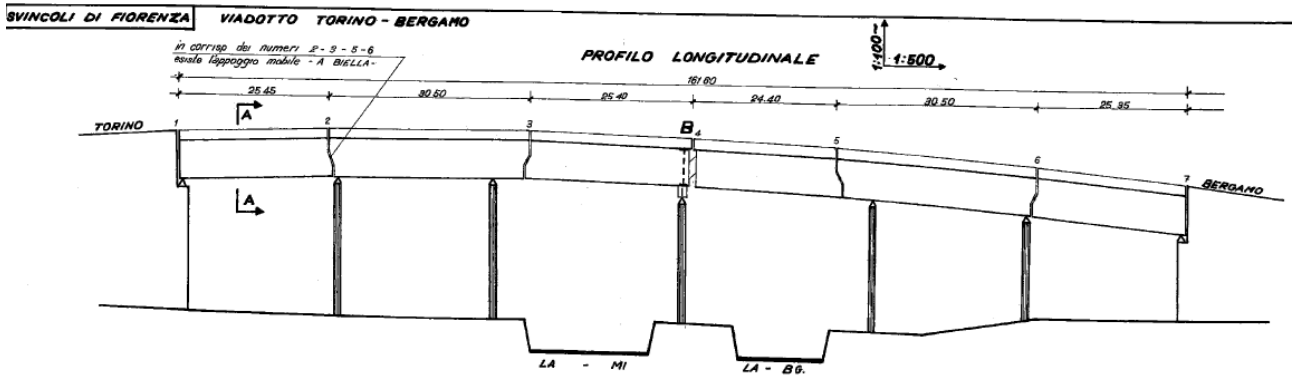

Figure 1-2: 210 - longitudinal section

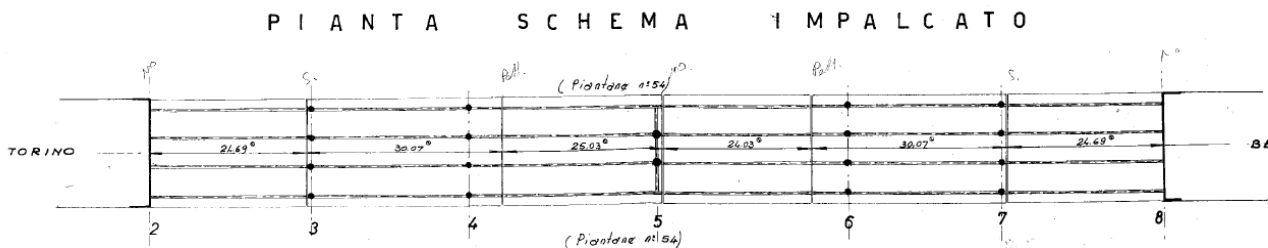

Figure 1-3: 210 - plan

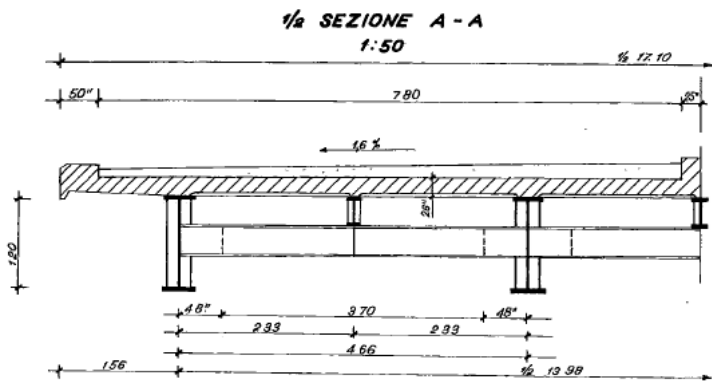

Figure 1-4: 210 - half of the transverse section

Two carriageways of 7.80m width are present. One which comes from Turin and is directed to Trieste, and another one with opposite direction. These two carriageways are separated by a median strip of 0.50m. Moreover, two different abutments are present: one situated in Turin direction and one in Bergamo direction.

In this case, the deck 1, characterized by a length of 25.45m is monitored.

1.1.2 223 bridge

The 223 bridge is part of the A8 motorway Milan – Varese. This bridge is composed of 12 decks. The length of these decks is in a range between 24.55 and 30.50m (see Figure 1-5), so its total length is equal to 341.5m. It is characterized by a transversal width equal to 16.00m and in this case only one carriageway is present (see Figure 1-7).

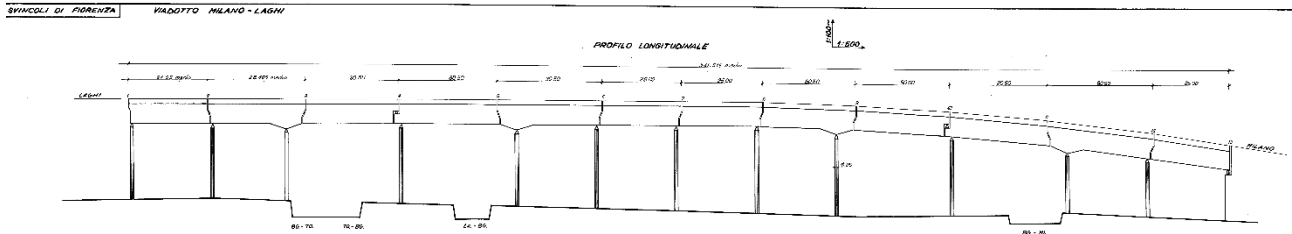

Figure 1-5: 223 - longitudinal section

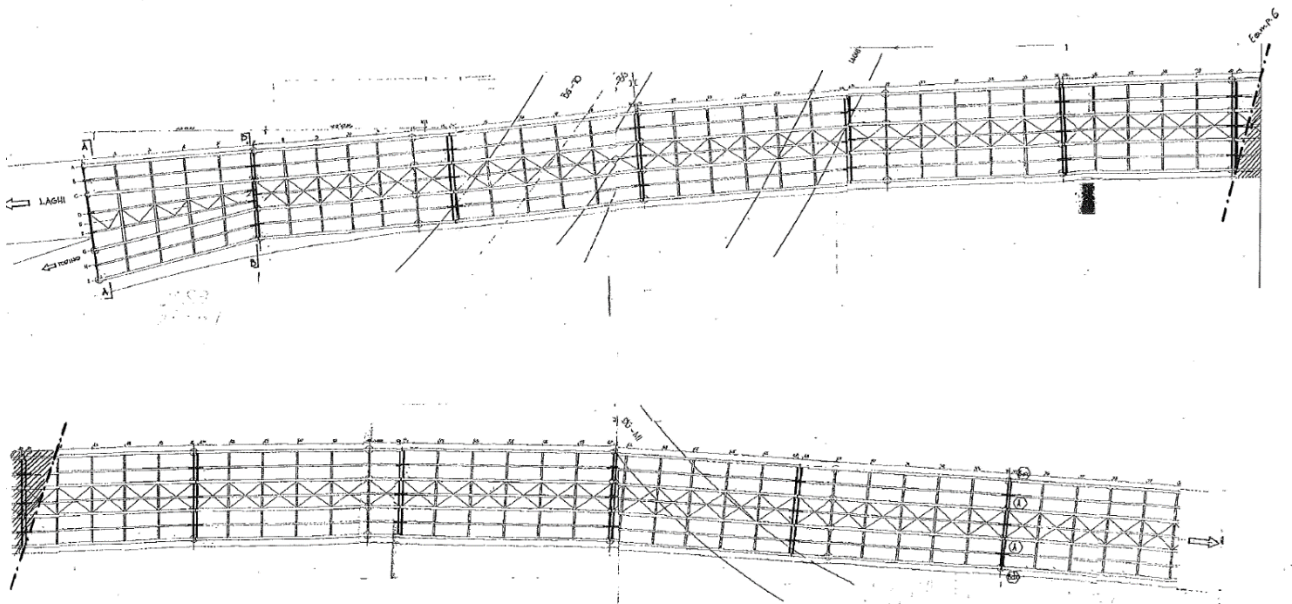

Figure 1-6: 223 - plan

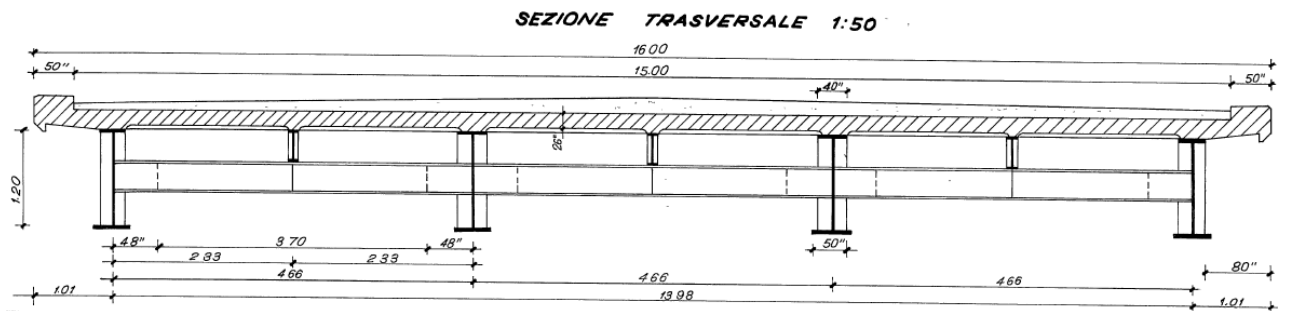

Figure 1-7: 223 - transverse section

Three lanes are directed toward Varese, and one exit lane merge the traffic flow toward A4 motorway Trieste – Turin (see Figure 1-6).

The monitored decks in this case are two: deck number 2 and deck number 6. Both are characterized by the same length, which is equal to 25.00m. This bridge is considered like the point in which one the A8 Milan – Varese motorway begins.

1.1.3 2A2 bridge

The 2A2 bridge give the connection between A8 motorway Milan – Varese and the A4 motorway Trieste – Turin. It is a bridge defined by the presence of 11 decks each one 25.00m long (see Figure 1-8). Its total length is equal to 271.36m. The transversal width is equal to 8.80m. The carriageway in this case is composed by a traffic lane and a shoulder.

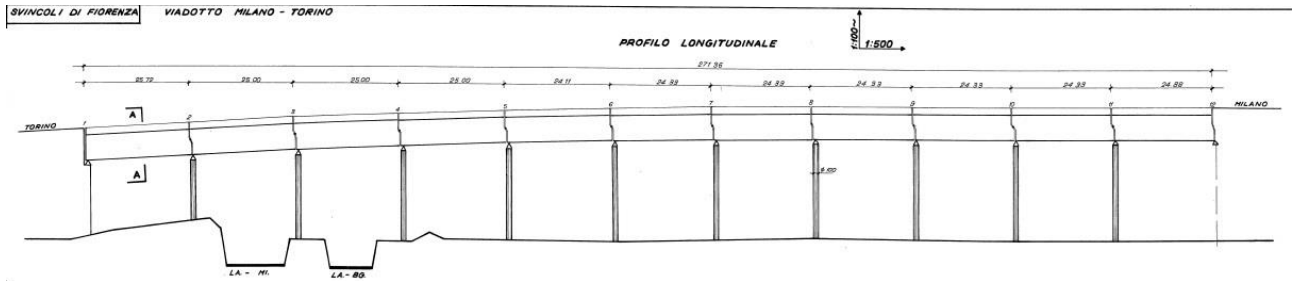

Figure 1-8: 2A2 - longitudinal section

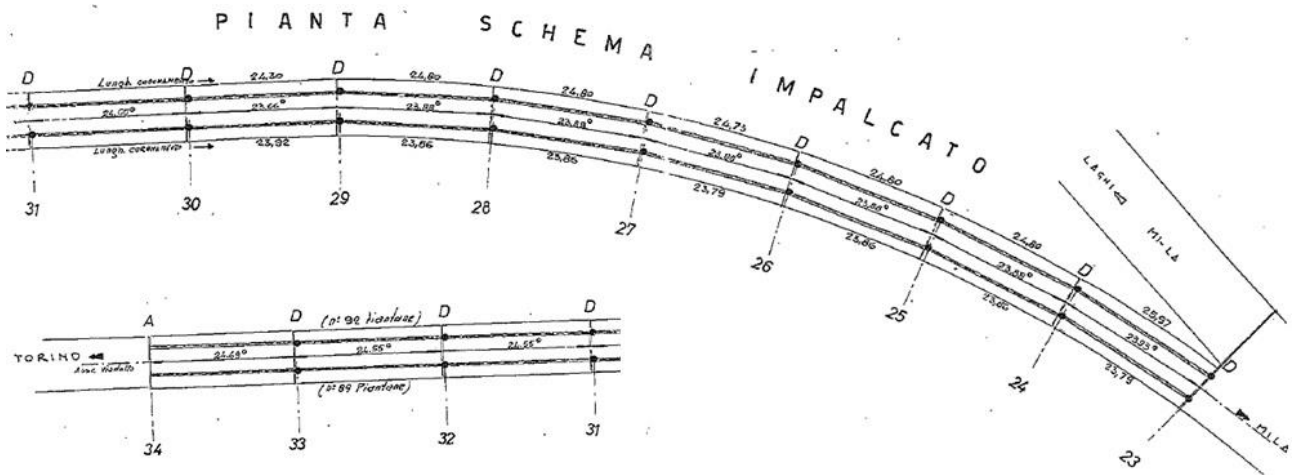

Figure 1-9: 2A2 - plan

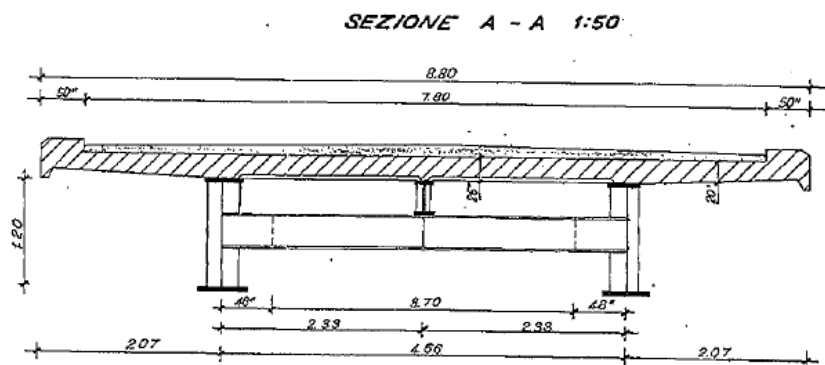

Figure 1-10: 2A2 - transverse section

Like for the 223 bridge, 2 decks are monitored. They are the deck number 4 and the deck number 5. In this case they are contiguous, so they share together the same group of piles.

1.1.4 233 bridge

The 233 bridge is part of the Giovanni Battista Grassi road, which connect Milan city with Baranzate city. It is composed of 12 decks of variable length (see Figure 1-11). Its total length is equal to 338.50m. The transversal width in this case is equal to 17.00m. One carriageway is present. It is composed by two car lanes and two tram rails which are situated in the middle. The monitored decks are the deck number 5 and the deck number 6. These have a span equal to 25.00m.

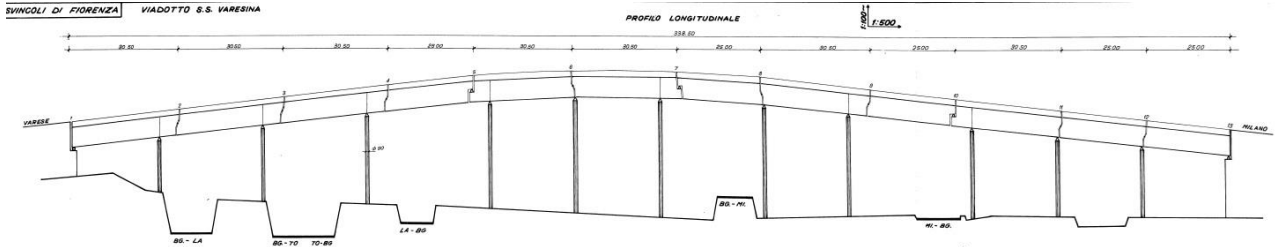

Figure 1-11: 233 - longitudinal section

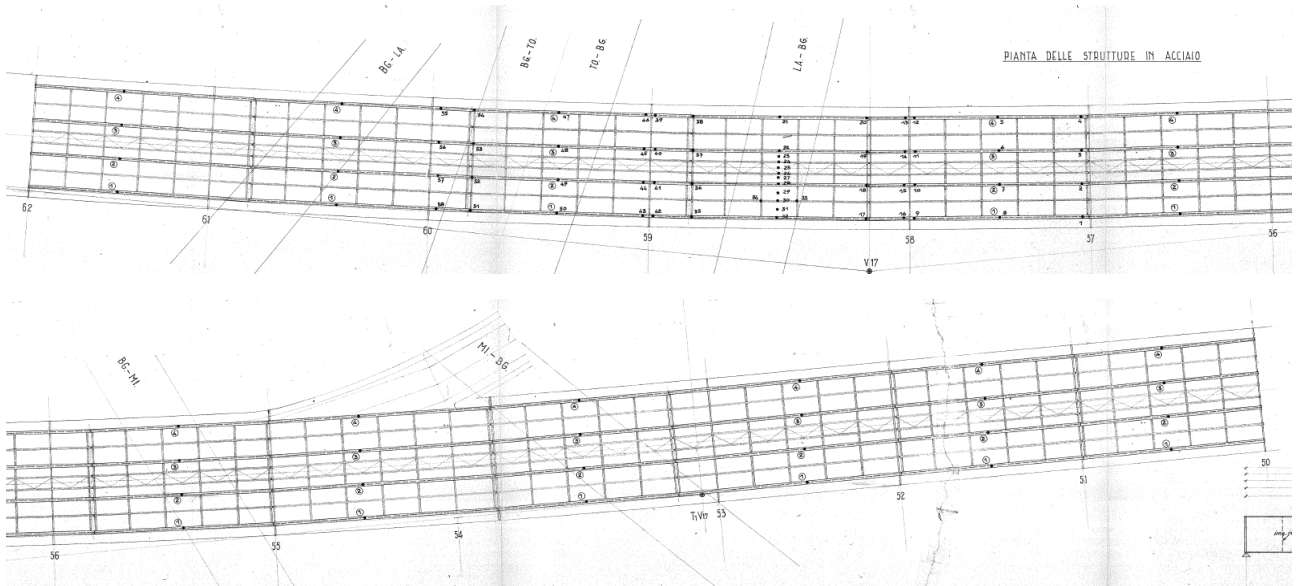

Figure 1-12: 233 - plan

The transversal width in this case is equal to 17.00m (see Figure 1-13). One carriageway is present. It is composed by two car lanes and two tram rails which are situated in the middle. The monitored decks are the deck number 5 and the deck number 6. These have a span equal to 25.00m.

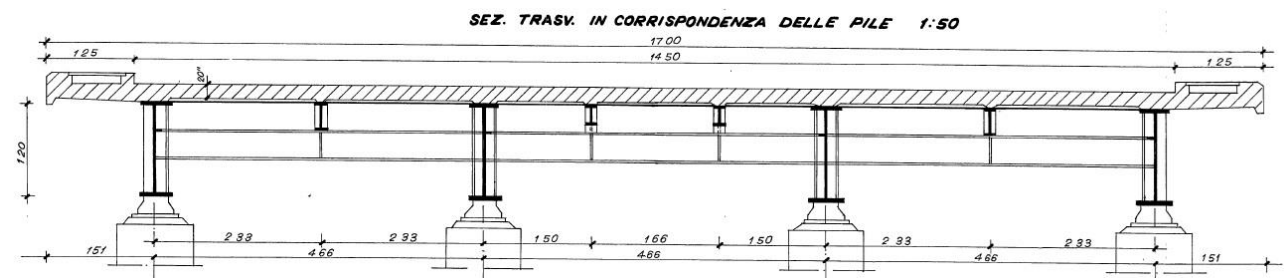

Figure 1-13: 233 - transverse section

1.1.5 2B4 bridge

The 2B4 bridge is part of the road which permit to go from the Viale Certosa interchange to Baranzate city. It is composed of 3 decks, each one characterized by a span equal to 20.00m (see Figure 1-14 and Figure 1-15). So, its total length is equal to 60.00m. The monitored deck is the deck number 3. The transverse section is 8.46m width and only one traffic lane is present on the carriageway (see Figure 1-16).

PROFILO LONG. SCHEMA IMPALCATO

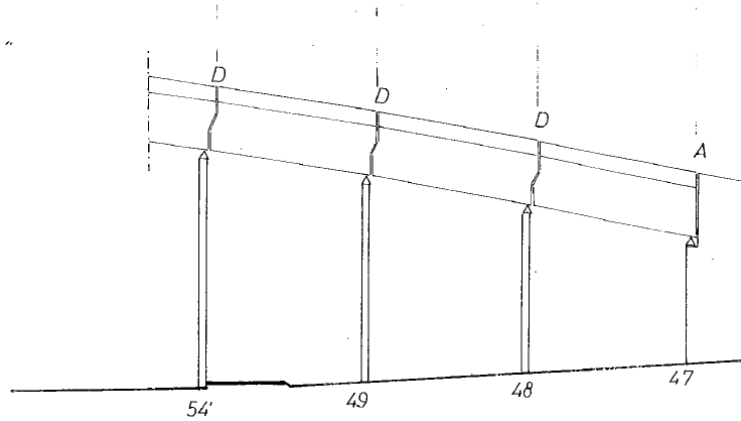

Figure 1-14: 2B4 - longitudinal view

PIANTA SCHEMA IMPALCATO

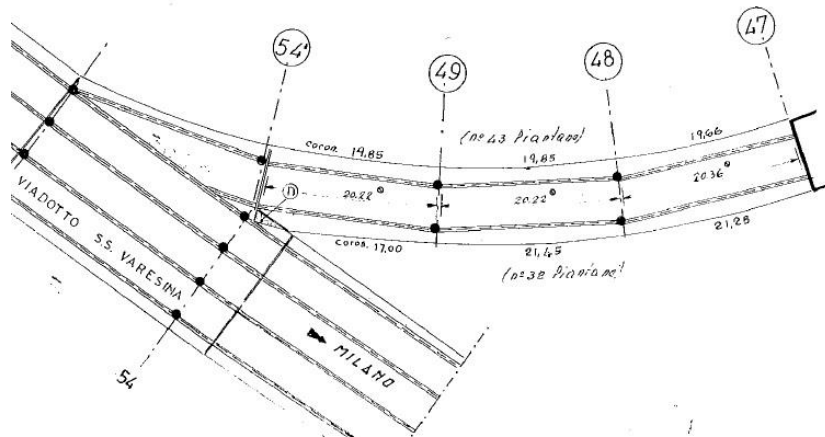

Figure 1-15: 2B4 - plan

SEZIONE A - A 1: 50

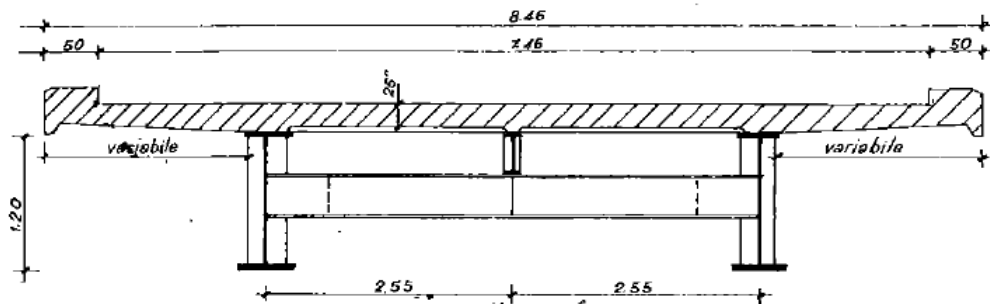

Figure 1-16: 2B4 - transverse section

1.1.6 243 bridge

Finally, the 243 bridge is an interchange which permit to leave the A4 Trieste – Turin motorway and go toward the Viale Certosa interchange. It is characterized by the presence of 6 decks of variable span. The total length of this bridge is equal to 172.67m. They are 2 monitored decks, which have a span equal to 25.00m. In this case the carriageway is composed of 2 lanes, and the transverse section width is equal to 8.80.

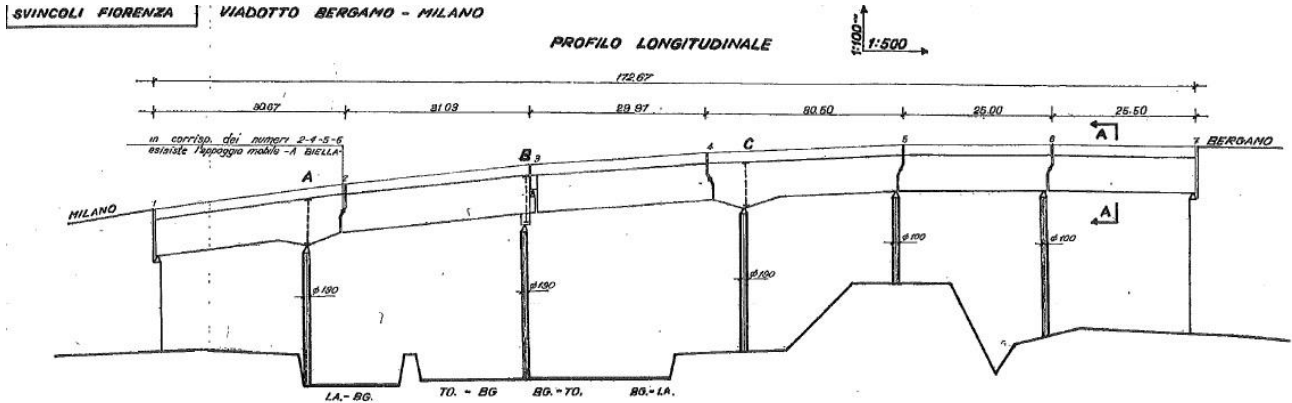

Figure 1-17: 243 - longitudinal section

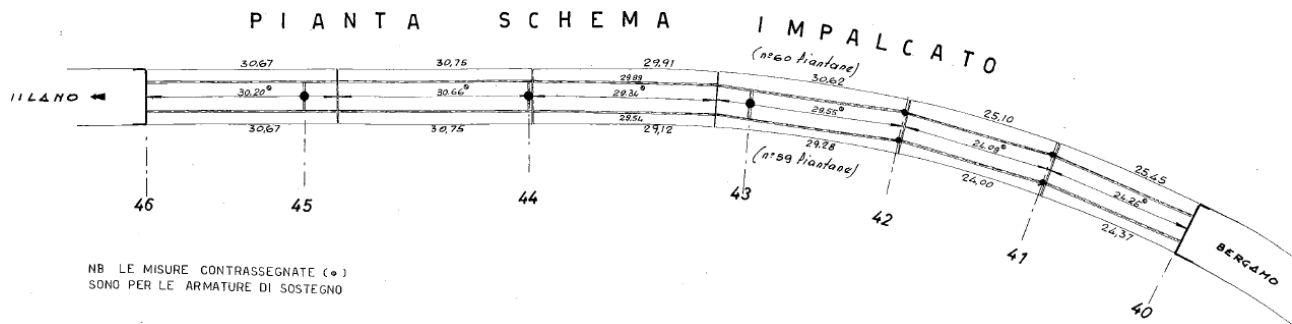

Figure 1-18: 243 - plan

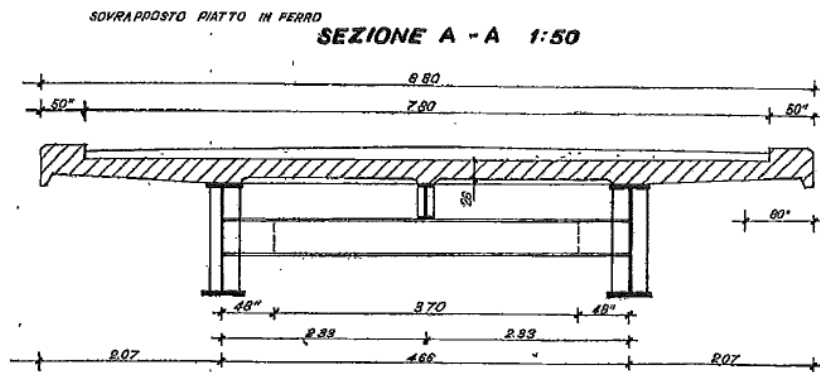

Figure 1-19: 243 - transverse section

From these six structures, the 223 and the 2A2 bridges have been chosen to be analyzed. This have been done because these structures have two pillars which are contiguous. So, the behavior of 2A2 is influenced by the 223 bridge.

1.2 Description of the monitoring system

The monitoring system is made of a set of triaxial accelerometers, called SHM. They are useful for studying the modal parameters of the structures. The acceleration of the point in which one they are installed can be measured. This permit to obtain the proper natural frequencies of the structure. They can be used for monitoring process of bridges, dams or buildings. Are battery-powered devices and has an operating autonomy up to 8 years. The characteristics of this typology of sensors are: ensure high performance; have a high autonomy and reliability; the base set-up of the registered data can be modified from the monitoring center; they don't need any wiring connection, so the cost of installation is reduced.



Figure 1-20: Type of accelerometer

The triaxial accelerometer is a “plug and play” type of accelerometer. When the antenna has been tightened, the device starts to register and send the data to the control center. In order to guarantee a correct mode of operation of the system, some installation steps should be respected. First of all, the three-axis reported on the accelerometer should coincide with the axis of the structure. Secondly, when on the monitored structure are installed more devices, all need to have the same orientation system. Finally, all the accelerometers should be installed before the activation of the Gateway system.

The accelerometer registers the acceleration in three directions: vertical (x), longitudinal (y) and transverse (z). This registration is done with a sampling rate of 80Hz. The acceleration values are expressed in mg. This type of devices has been installed in 4 different points of the deck: L/2, L/4, L/8 and nearby the pillar. All the sensors are powered by a cell and the data registered are send through a wireless system.

1.3 Description of the acquisition mode

The accelerometer registers two different typologies of signals:

- Scheduled acquisitions.
- Triggered acquisitions.

The scheduled acquisition is a 102.4s long and permits to record 8192 samples on each axis of the triaxial instrument. This type of acquisitions are planned acquisitions. They can be done at a fixed rate set by the user (every 1h, 2h, 6h, 12h, 24h). This typology of acquisition is used to obtain the proper natural frequencies. An example of this typology of registration is reported in the next figures.

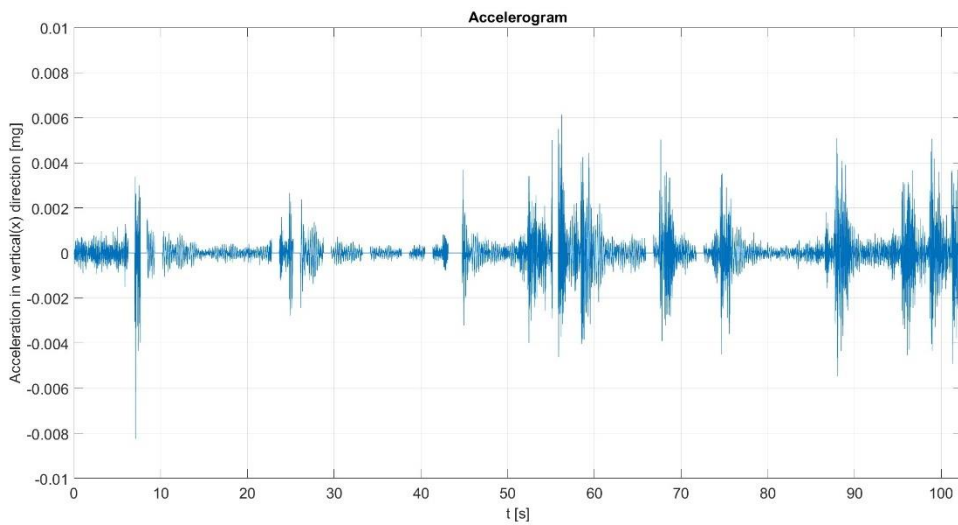

Figure 1-21: Accelerogram in vertical (x) direction

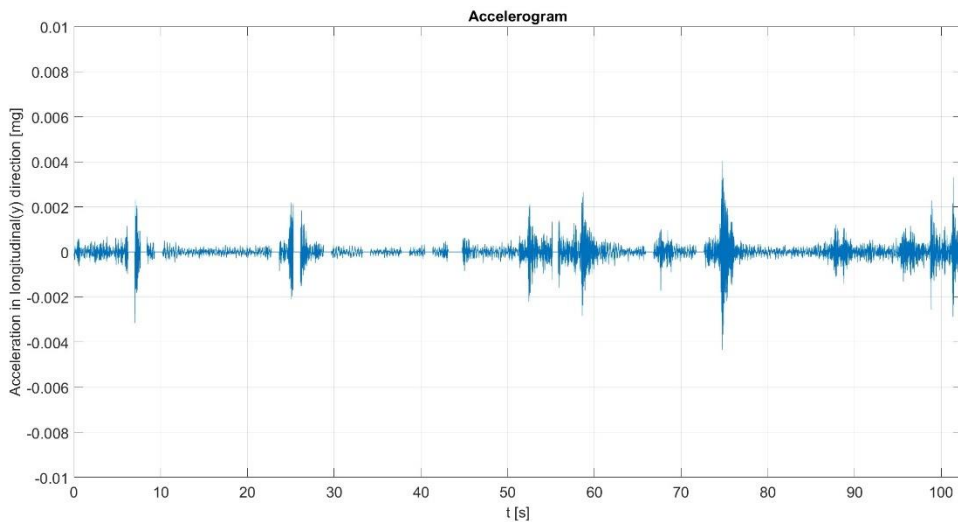

Figure 1-22: Accelerogram in longitudinal (y) direction

Monitoring activity on Fiorenza Node of A4 Highway

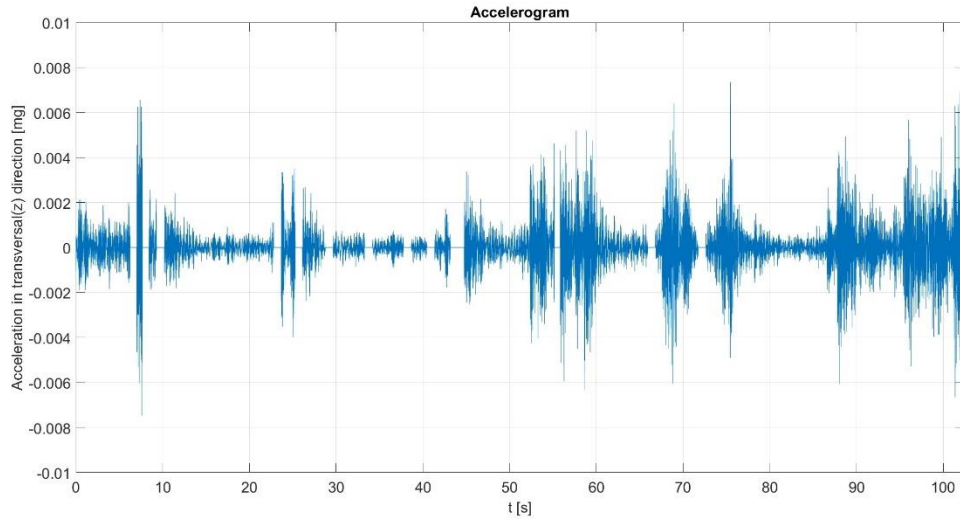

Figure 1-23: Accelerogram in transversal (z) direction

The second typology of acquisition is the triggered one. They are 12.8s long accelerometers and the number of samples registered in this case is equal to 1024. This type of acquisition is made every time a threshold value is reached. The threshold value is set in remote mode through a web platform. Three examples are reported hereafter for this kind of registration.

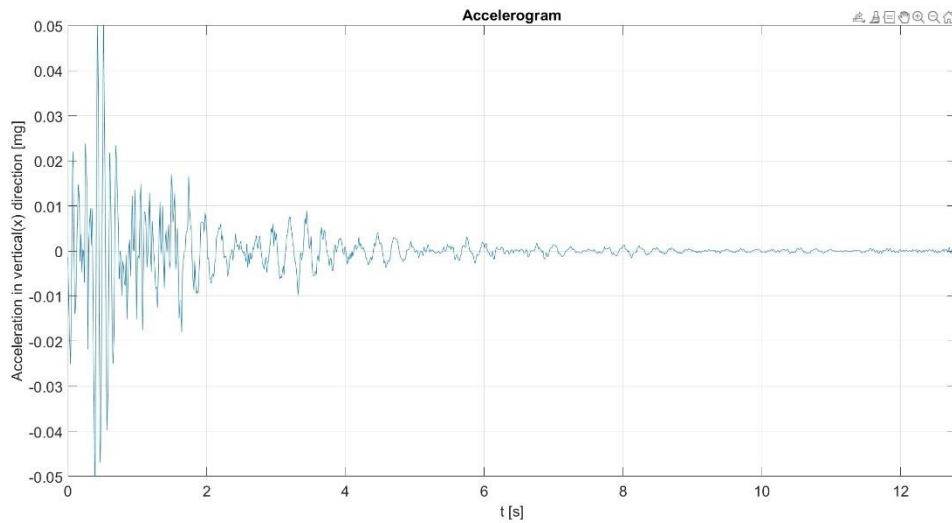

Figure 1-24: Accelerogram in vertical (x) direction

Monitoring activity on Fiorenza Node of A4 Highway

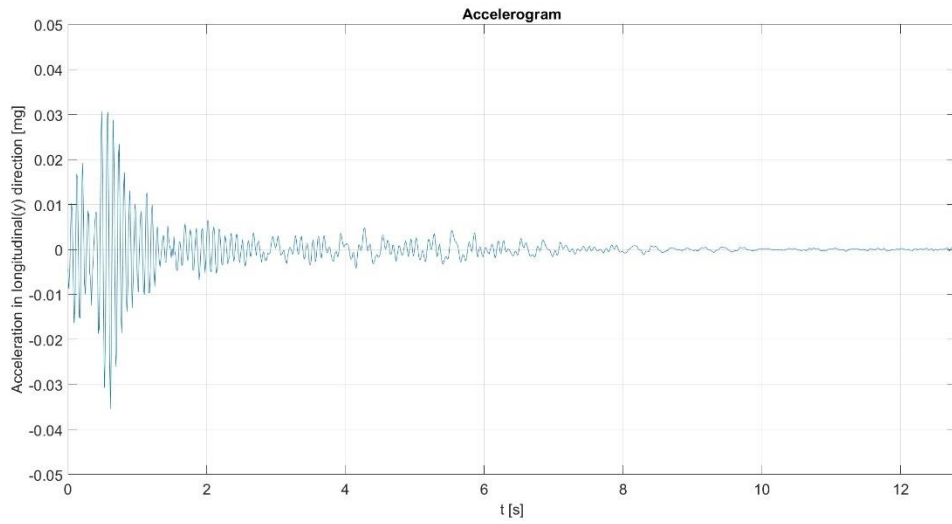

Figure 1-25: Accelerogram in longitudinal (y) direction

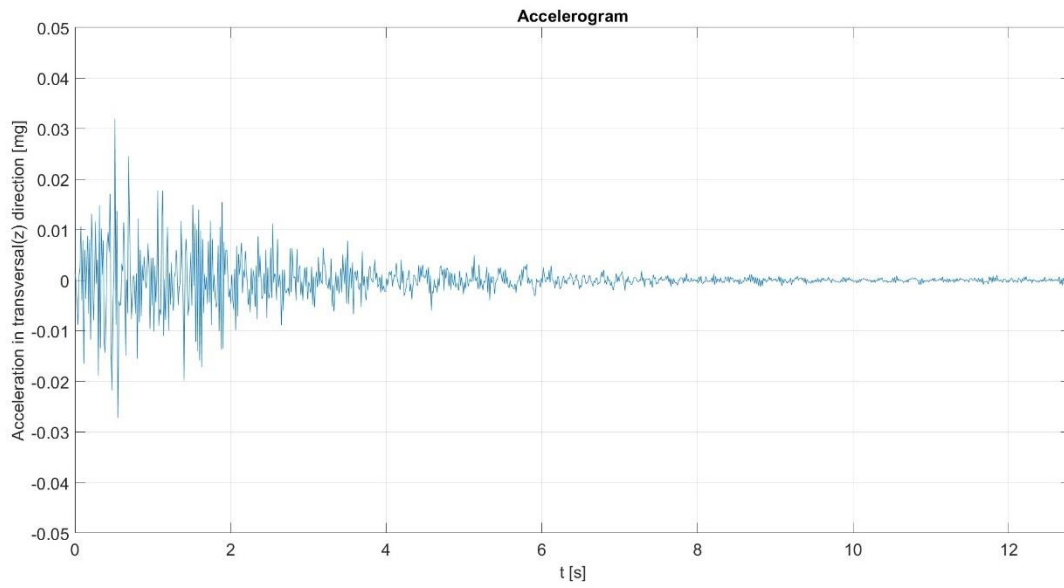

Figure 1-26: Accelerogram in transversal (z) direction

2. Scheduled acquisitions processing

2.1 Introduction

To define the proper natural frequencies of the structure, a MATLAB code was written. This code receives in input all the accelerograms recorded during the entire year.

Three different procedures are implemented to define which accelerograms are the one with the higher energy: computation of the standard deviation; computation of the area defined by the power spectral density function; computation of the peak defined by the power spectral density function.

To define the standard deviation, firstly the input data have been uploaded. At this point, a filter was applied, so finally the standard deviation was computed separately in the three directions: vertical (x), longitudinal (y) and transverse (z).

For the definition of the accelerograms characterized by the higher area under the curve of the function and the one with the higher peak, like before, a filter was applied to the input data. So, the power spectral density function was computed. At this point, were selected the data with the higher peak and with the higher area.

After the MATLAB analysis have been done, all the correspondent frequencies of the peaks of the power spectral density function have been reported in the tables of the chapter 3, 4, 5 and 6. Like could be noticeable, there is a strong relationship between the results obtained by using these three different procedures, so we can conclude that the accelerogram used in the analysis are the one defined by the higher energy. The results have been separated into a time range of a month, so the variation of the frequencies could be defined during an entire year for the three directions: vertical, longitudinal and transverse.

Moreover, for every peak the numerosity, the mean value, the standard deviation and the coefficient of the variation have been computed.

The numerosity correspond to the number of the data that are present in a specific collection.

The mean value is the average of a set of numbers, and it has been computed in order to define the central tendency of the collected frequencies. It has been computed like the ratio between the sum of all observations and the total number of the observations.

The standard deviation indicates the degree of dispersion of the data relative to its mean value. It corresponds to the square root of the variance, so it has been computed like:

$$\sigma = \sqrt{\frac{\sum(X - \mu)^2}{N}}$$

Where:

- X – value in the data acquisition;
- μ – mean value;
- N – total number of observations.

The coefficient of variation represents the percentage of dispersion of the data set. It is computed like the ration between the standard deviation and the mean value.

$$C. o. V = \frac{\sigma}{\mu}$$

3. Bridge 2A2 deck 4

The Bridge 2A2 counts 2 monitored decks: span 4 and span 5 (see Figure 3-1).

On each deck, 4 sensors are present: one in the midspan ($L/2$), one at $L/4$ of the span, one at $L/8$ of the span and the last one near the pier (see Figure 3-2).

The sensors present on deck number 4 are:

- 3099D – situated in the midspan;
- 30EB4 – situated at a distance of $L/4$;
- 31639 – situated at a distance of $L/8$;
- 30D41 – situated on the pier.

Monitored deck

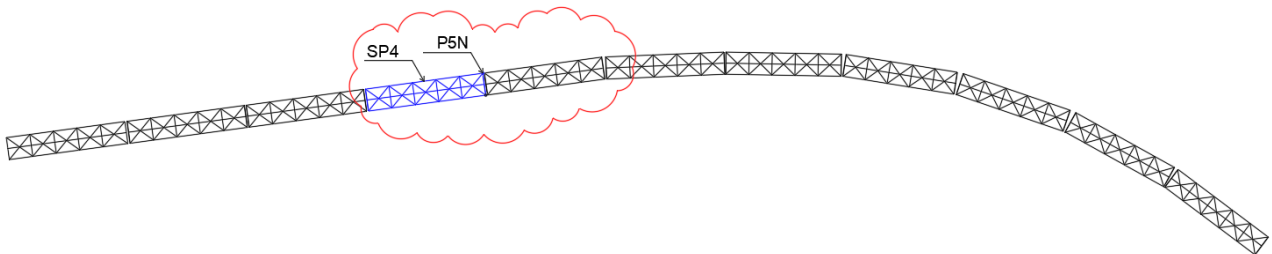

Figure 3-1 Deck 4 of 2A2 bridge

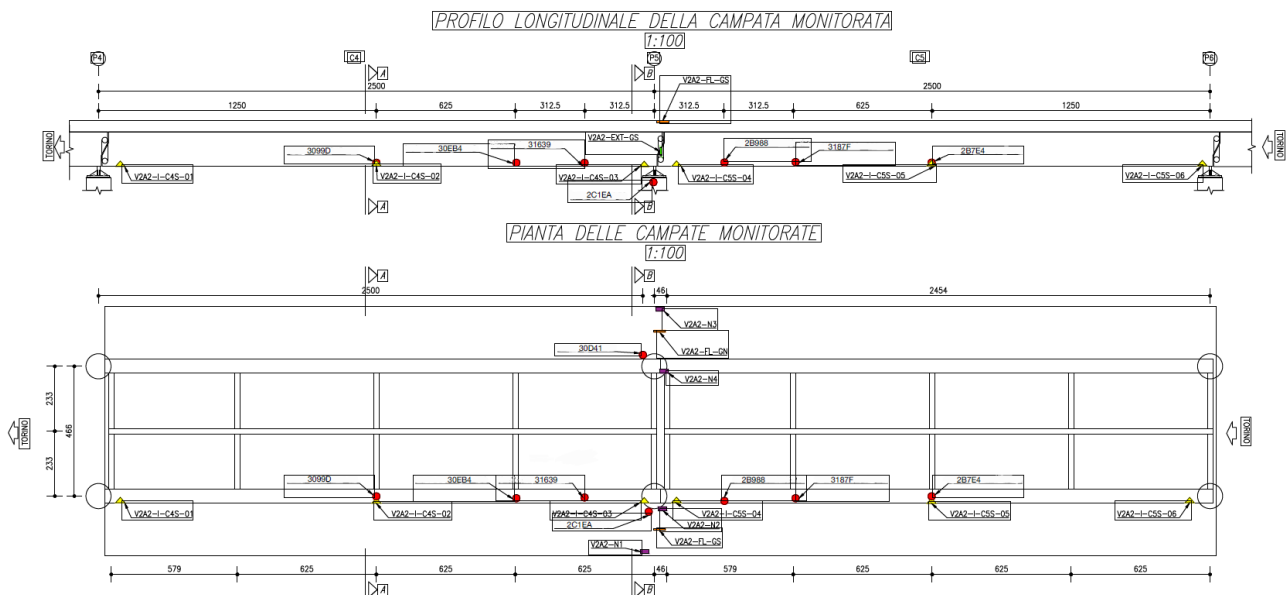

Figure 3-2 Sensor positions on deck 4 and 5 of 2A2 bridge

All the accelerograms registered at scheduled times (every 6 hours) and long 102s have been analyzed and the results are represented in the following Annexes:

- Annex 1 – Sensor 3099D
- Annex 2 – Sensor 30EB4
- Annex 3 – Sensor 31639
- Annex 4 – Sensor 30D41

The mean value frequencies identified for this deck are presented in Table 3-1.

Table 3-1 2023 Average natural frequencies [Hz] identified for 2A2 deck 4

Direction	Frequency	L/2	L/4	L/8	Pier
Vertical	1 st	2.75	2.70	2.75	2.76
	2 nd	3.43	3.28	3.22	3.67
	3 rd	3.75	3.75	3.75	4.01
	4 th	4.29	4.31	4.40	4.57
Longitudinal	1 st	3.06	3.06	3.02	3.03
	2 nd	3.60	3.60	3.61	3.47
	3 rd	4.00	3.99	3.96	4.02
	4 th	4.53	4.55	4.49	4.55
Transverse	1 st	2.25	2.26	2.23	2.20
	2 nd	2.80	2.79	2.77	2.76
	3 rd	3.70	3.65	3.73	3.66
	4 th	4.26	4.30	4.57	4.50

3.1 2A2 SP4 L/2 Sensor 3099D

The natural frequencies have been now classified and represented in such a way to obtain the variation of the values during the year. So, each peak value has been identified and the following representation for the vertical, longitudinal and transverse direction have been obtained.

Table 3-2 2023 natural frequencies [Hz] identified for sensor 3099D – 2A2 SP4 L/2

	Vertical direction				Longitudinal direction				Transverse direction			
	1° peak	2° peak	3° peak	4° peak	1° peak	2° peak	3° peak	4° peak	1° peak	2° peak	3° peak	4° peak
Numerosity	5	2	107	42	100	25	94	14	39	104	8	98
MEAN	2.75	3.43	3.75	4.29	3.06	3.60	4.00	4.53	2.25	2.80	3.70	4.26
SD	0.11	0.01	0.05	0.09	0.07	0.13	0.10	0.14	0.05	0.11	0.06	0.09
C.o.V.	4.0%	0.1%	1.3%	2.1%	2.4%	3.6%	2.5%	3.0%	2.4%	3.9%	1.5%	2.2%
Rating	4%	2%	100%	36%	85%	19%	79%	11%	33%	79%	7%	85%
1 gen-23	2.89		3.83		3.09		3.91	4.6	2.26	2.62		4.34
2 gen-23			3.83		3.09		3.94	4.6		2.73		4.41
3 gen-23			3.79		3.16		4.01			2.8		4.38
1 gen-23			3.83		3.09		3.91	4.6	2.27	2.62		4.34
2 gen-23			3.83		3.09		4.02			2.73		4.41
3 gen-23			3.79	4.41	3.16		3.94	4.6		2.81		4.38
1 gen-23			3.83		3.09		3.91	4.6	2.27	2.62		4.33
2 gen-23			3.83		3.16		4.02			2.73		4.41
3 gen-23			3.79		3.09		3.95	4.6		2.81		4.41
1 feb-23			3.79	4.34	3.13		3.98	4.65		2.73		4.33
2 feb-23			3.79	4.26	3.05		4.1			2.81		4.38
3 feb-23			3.79		3.05		3.98			2.73		4.3
1 feb-23			3.79	4.34	3.13		3.98	4.69		2.73		4.34
2 feb-23			3.79		3.05		4.1			2.73		4.38
3 feb-23			3.79		3.05		3.98			2.77		4.3

Monitoring activity on Fiorenza Node of A4 Highway

1	feb-23		3.79		3.13		3.98	4.65		2.73		4.34
2	feb-23		3.79		3.05		4.1			2.77		4.38
3	feb-23		3.79	4.34	3.09		3.91			2.77		4.3
1	mar-23		3.75		3.01		4.14			2.81		4.26
2	mar-23		3.75		3.01		3.94		2.2	2.73		
3	mar-23		3.79		3.13		3.99			2.77		
1	mar-23		3.75		3.01		4.12			2.85		4.26
2	mar-23		3.75		3.01		3.96		2.2	2.77		4.26
3	mar-23		3.79		3.05		3.86			2.77		
1	mar-23		3.75		3.01		4.12			2.85		4.26
2	mar-23		3.75		3.01		3.96		2.2	2.77		4.22
3	mar-23		3.79		3.05		3.86			2.77		
1	apr-23		3.75	4.22	3.09		4.06			2.77		4.26
2	apr-23		3.75	4.3	3.01	3.75	4.2		2.23	2.77		4.26
3	apr-23		3.79		3.05	3.83			2.23	2.81		4.3
1	apr-23		3.75	4.22	3.09		4.06		2.23	2.77		4.26
2	apr-23		3.75	4.3	3.01	3.78	4.2			2.77		4.26
3	apr-23		3.79	4.38	3.05	3.83			2.23	2.81		4.3
1	apr-23		3.75	4.22	3.13		4.02			2.77		4.26
2	apr-23		3.75	4.3	3.09		4.06		2.23	2.81		4.3
3	apr-23		3.79	4.38	3.01	3.77	4.2		2.19	2.73		4.3
1	mag-23	2.62	3.71	4.22	3.01		4.21			2.77		4.14
2	mag-23		3.79	4.22	3.16		4.06		2.1	2.77		4.25
3	mag-23	2.81	3.67	4.22	3.01		4.06		2.3	3.05		4.21
1	mag-23	2.62	3.71	4.22	3.01		4.06			2.77		4.14
2	mag-23	2.81	3.67	4.22	3.16		3.89			2.77		4.23
3	mag-23		3.78	4.22	3.01		4.02			3.01		4.22
1	mag-23		3.79	4.22	3.01		4.06			2.73		4.14
2	mag-23		3.71	4.18	3.16		3.88		2.1	2.77		4.25
3	mag-23		3.71		2.97		3.89		2.3	2.81		4.18
1	giu-23		3.71		3.05		3.95		2.27	2.83		4.02
2	giu-23		3.67			3.47			2.31	2.89		4.22
3	giu-23		3.71		3.16		4.02		2.3	3.2		4.18
1	giu-23		3.71		3.05		3.95		2.3	2.81		4.02
2	giu-23		3.71				3.91		2.3	2.89		4.22
3	giu-23		3.67		3.05		3.83		2.34	3.32		4.18
1	giu-23		3.67		3.05		3.95		2.3	2.89		4.18
2	giu-23		3.71			3.48			2.3	2.89		4.22
3	giu-23		3.71		3.09		3.8		2.27	2.81		4.02
1	lug-23		3.71	4.18	3.2		3.98		2.3	2.85		
2	lug-23		3.71		3.01					3.01		4.1
3	lug-23		3.71		3.24		4.1	4.41		2.97		4.14
1	lug-23		3.71	4.14	3.2		3.98		2.3	2.85	3.79	
2	lug-23		3.71		3.01					3.01		4.14
3	lug-23		3.71		3.24		4.15	4.45		2.97		4.14
1	lug-23		3.71	4.14	3.01				2.3	2.85	3.81	
2	lug-23		3.71		3.2		3.98			2.97		4.14

Monitoring activity on Fiorenza Node of A4 Highway

3	lug-23		3.71		3.09		3.98		3.01		4.14	
1	ago-23		3.71	4.22	3.13	3.55	3.91	4.3	2.23	2.7	4.21	
2	ago-23		3.71		3.01	3.5	4.14			3.05	4.1	
3	ago-23		3.75	4.26	3.01		3.98		2.3			
1	ago-23		3.71	4.18	3.13	3.55	3.91	4.3	2.23	2.7	4.29	
2	ago-23		3.75		2.98	3.5	4.14			3.04	4.17	
3	ago-23		3.75		3.01		3.95		2.3			
1	ago-23		3.71	4.18	3.13	3.55	3.91	4.3	2.3		4.14	
2	ago-23		3.75		3.01	3.5	4.14			2.77	4.18	
3	ago-23		3.71		3.01		3.95		2.23	2.7	4.3	
1	set-23		3.79		2.97		3.8			2.73	4.14	
2	set-23		3.75		3.05		3.88			2.73	4.28	
3	set-23		3.75		2.85		4.12			2.81	4.14	
1	set-23		3.79		2.97		3.8			2.73	4.18	
2	set-23		3.75		3.05		3.86			2.73	4.34	
3	set-23		3.75		2.85		4.14			2.81	4.18	
1	set-23		3.79		2.97		3.8			2.73	4.18	
2	set-23		3.75		3.05		3.87			2.73	4.3	
3	set-23		3.75		2.9		4.1			2.81	4.22	
1	ott-23	3.42	3.86	4.34	3.09	3.61				2.81	4.3	
2	ott-23		3.75	4.3			4.02			2.77	4.25	
3	ott-23		3.65	4.44	3.01	3.71				2.73	4.22	
1	ott-23	3.43	3.86	4.35	3.09	3.6				2.81	4.3	
2	ott-23		3.63	4.45		3.67	4.02			2.77	4.26	
3	ott-23		3.75	4.3	3.01	3.71				2.77	4.22	
1	ott-23		3.75	4.3	3.09	3.63				2.81	4.3	
2	ott-23		3.75	4.33			4.02			2.77	4.26	
3	ott-23		3.79	4.3	2.87		3.95			2.81	4.18	
1	nov-23		3.71	4.38	-	3.48	4.06			2.7	3.67	4.37
2	nov-23		3.83		3.01	3.67				2.73	4.3	
3	nov-23		3.83		3.24		3.99			2.73	3.67	4.25
1	nov-23		3.71	4.38	3.05	3.48	4.06			2.73	3.67	4.38
2	nov-23		3.83		3.01		3.76			2.73	4.3	
3	nov-23		3.83		3.09		3.87			2.7	3.67	4.25
1	nov-23		3.71	4.38	3.05	3.48	4.06			2.73	3.67	4.38
2	nov-23		3.79		3.01	3.66	3.98			2.73	4.3	
3	nov-23		3.83			3.32	4.14			2.7	3.67	4.26
1	dic-23		3.75	4.49	3.09		4.06			2.77	4.38	
2	dic-23		3.75		3.09		4.06		2.23	2.77	4.3	
3	dic-23		3.79		3.05		4.1		2.19	2.77	4.37	
1	dic-23		3.75	4.49	3.09		4.06			2.77	4.38	
2	dic-23		3.75		3.05		4.1		2.23	2.77	4.38	
3	dic-23		3.75		3.09		4.06		2.23	2.77	4.34	
1	dic-23		3.75		3.09		4.06			2.77	4.38	
2	dic-23		3.79		3.13		4.1		2.23	2.77	4.38	
3	dic-23		3.75	4.49	3.05		4.1		2.18	2.77	4.3	

3.1.1 Vertical direction (x)

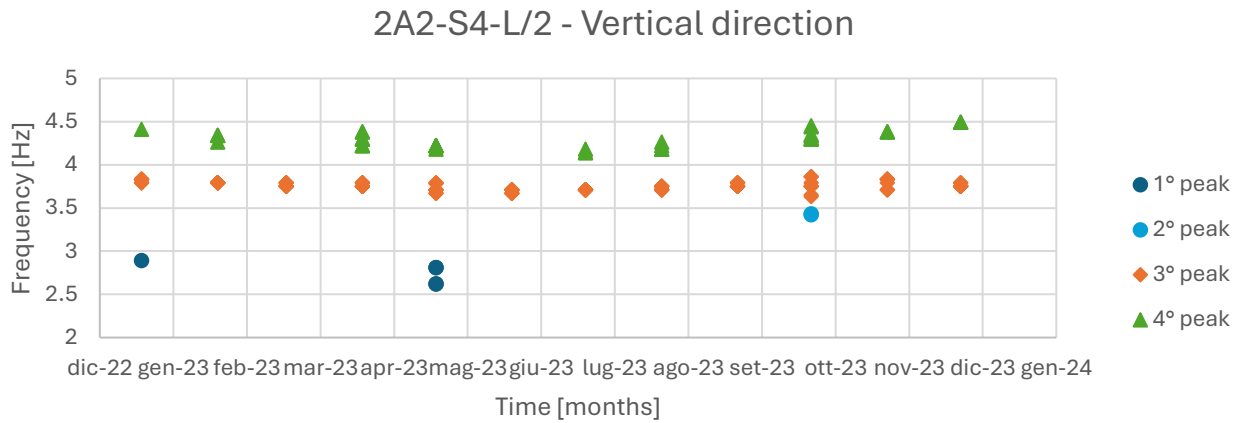

Figure 3-3: 2A2-S4-L/2 - Natural frequencies obtained in vertical direction

3.1.2 Longitudinal direction (y)

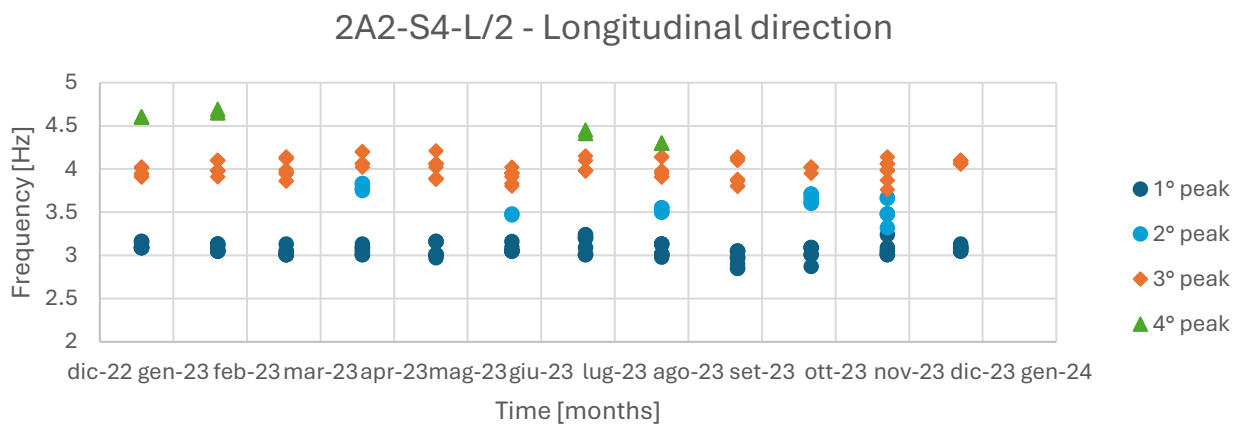

Figure 3-4: 2A2-S4-L/2 - Natural frequencies obtained in longitudinal direction

3.1.3 Transverse direction (z)

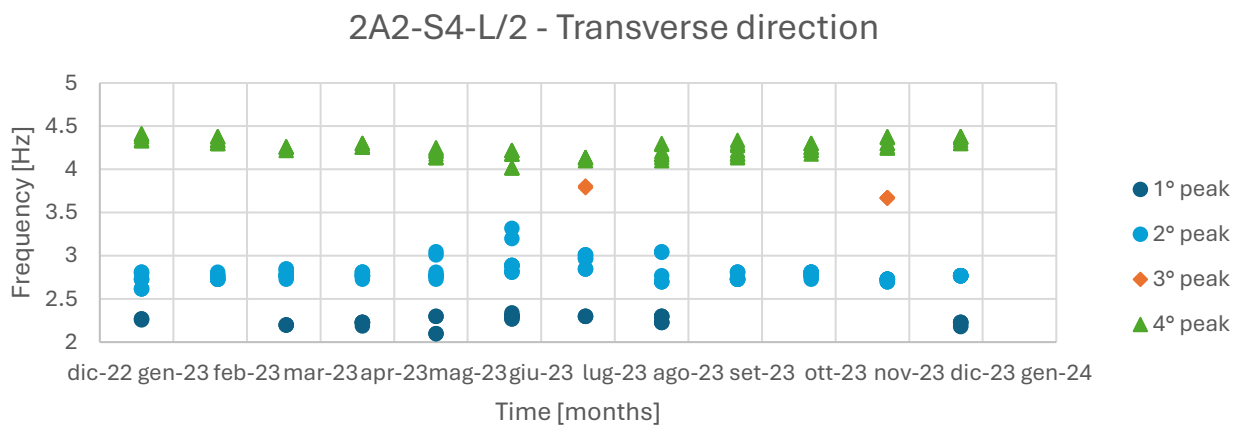

Figure 3-5: 2A2-S4-L/2 - Natural frequencies obtained in transverse direction

3.2 2A2 SP4 L/4 Sensor 30EB4

The natural frequencies have been now classified and represented in such a way to obtain the variation of the values during the year. So, each peak value has been identified and the following representation for the vertical, longitudinal and transverse direction have been obtained.

Table 3-3 2023 natural frequencies [Hz] identified for sensor 30EB4 – 2A2 SP4 L/4

	Vertical direction				Longitudinal direction				Transverse direction			
	1° peak	2° peak	3° peak	4° peak	1° peak	2° peak	3° peak	4° peak	1° peak	2° peak	3° peak	4° peak
Numerosity	18	28	107	63	96	33	79	37	52	102	59	102
MEAN	2.70	3.18	3.75	4.31	3.06	3.60	3.99	4.55	2.26	2.79	3.65	4.30
SD	0.10	0.13	0.05	0.10	0.08	0.10	0.10	0.16	0.06	0.10	0.10	0.19
C.o.V.	3.7%	4.0%	1.3%	2.4%	2.6%	2.9%	2.5%	3.4%	2.9%	3.5%	2.7%	4.4%
Rating	14%	21%	100%	54%	81%	27%	67%	29%	43%	80%	49%	75%
1 gen-23			3.83		3.13		3.98	4.49		2.62	3.83	4.34
2 gen-23			3.83	4.68	3.13		3.95			2.73	3.71	4.45
3 gen-23			3.79	4.5	3.16		3.98			2.81	3.71	4.45
1 gen-23	2.81		3.83		3.09		3.98	4.96	2.27	2.62	3.87	4.3
2 gen-23			3.83	4.41	3.13		3.95	4.49		2.73	3.71	4.45
3 gen-23			3.83	4.41	3.16		3.98	4.57		2.81	3.75	4.34
1 gen-23	2.81		3.83		3.13		3.98	4.49	2.27	2.62	3.87	4.34
2 gen-23			3.83	4.41	3.13		3.95			2.81	3.79	4.45
3 gen-23			3.83		3.16		3.98	4.96		2.73	3.75	4.45
1 feb-23	2.77		3.83	4.38	3.13		3.95			2.73		4.33
2 feb-23			3.79		3.01		4.06			2.77	3.68	4.38
3 feb-23			3.79	4.34	3.05		3.95			2.73	3.71	4.22
1 feb-23	2.77	3.28	3.83	4.38	3.13		3.95	4.45	2.23	2.73		4.34
2 feb-23			3.79	4.34	3.05		4.06			2.77	3.63	4.38
3 feb-23			3.79		3.05		3.95			2.77	3.55	4.18
1 feb-23			3.79		3.13		3.95	4.45	2.22	2.73	3.51	4.34
2 feb-23			3.79	4.34	3.09		3.83		2.27	2.77	3.78	4.22
3 feb-23	2.77		3.83	4.38	3.01		4.1		2.22	2.77		4.3
1 mar-23		3.13	3.75	4.3	3.01		4.16			2.77	3.58	4.26
2 mar-23	2.78		3.75	4.3	3.01		3.91		2.34	2.77		4.73
3 mar-23			3.75		3.13		3.98			2.73	3.49	4.73
1 mar-23			3.75	4.3	3.01		4.16			2.81	3.48	4.26
2 mar-23	2.77		3.75	4.33	3.01		3.91	4.57	2.34	2.81		4.73
3 mar-23			3.75		3.05		3.83		2.22	2.73	3.4	4.3
1 mar-23			3.75	4.3	3.01		4.16			2.77	3.48	4.26
2 mar-23	2.77		3.75	4.34	3.01		3.91	4.57	2.23	2.81		4.26
3 mar-23			3.79		3.05		3.83		2.3	2.77		4.75
1 apr-23			3.75	4.22	3.09		4.1	4.74	2.23	2.73	3.61	4.22
2 apr-23			3.75	4.3	3.05		4.21	4.64	2.3	2.77	3.47	4.26
3 apr-23			3.75		3.09		3.75	4.69			3.61	4.22
1 apr-23		3.36	3.75	4.22	3.09		4.1		2.23	2.73	3.64	4.22
2 apr-23			3.75	4.34	3.05		4.22		2.29	2.77	3.6	4.25

Monitoring activity on Fiorenza Node of A4 Highway

3	apr-23		3.75	4.3	3.05		3.79			3.63	4.22
1	apr-23	3.36	3.75		3.09		4.1		2.77	3.59	4.26
2	apr-23		3.75		3.09		4.02		2.23	2.73	3.63
3	apr-23		3.75	4.38	3.09		4.02	4.61			3.63
1	mag-23		3.04	3.71	4.22	3.01		4.02		2.77	4.14
2	mag-23	2.77		3.79	4.22	3.09		3.91	2.01	2.73	3.69
3	mag-23			3.67	4.26	2.9	3.51	4.02	2.29	3.01	4.14
1	mag-23		3.04	3.71	4.22	3.01		3.98		2.77	4.14
2	mag-23			3.79	4.22	3.13		3.91	4.47	2.01	2.77
3	mag-23	2.77		3.67	4.26	2.89		4.02	2.29	3.01	4.18
1	mag-23		3.04	3.79	4.22	3.01		3.98		2.77	4.14
2	mag-23			3.71		3.09		3.86		2.77	3.69
3	mag-23			3.71	4.22	2.97		3.83	2.29	2.73	4.14
1	giu-23			3.71		3.05		3.98	4.74	2.3	2.81
2	giu-23		3.09	3.71	4.18		3.51			2.31	2.93
3	giu-23			3.71	4.18	3.05		3.79			3.01
1	giu-23		3.09	3.71	4.38	3.05		3.95		2.31	2.81
2	giu-23			3.71	4.38		3.52			2.3	2.93
3	giu-23			3.71		3.05		3.79			3.01
1	giu-23			3.71		3.05		3.95		2.31	2.81
2	giu-23		3.09	3.71	4.38	3.05		3.79		2.3	2.89
3	giu-23	2.71		3.71	4.38		3.52			2.38	2.89
1	lug-23	2.66		3.71	4.18	3.19		3.95		2.3	2.81
2	lug-23			3.71		3.21	3.67		4.45		2.95
3	lug-23		3.28	3.71		3.01		4.02			3.01
1	lug-23	2.66		3.71	4.18	3.2		3.95	4.38	2.3	2.81
2	lug-23			3.71		3.01					2.97
3	lug-23		3.28	3.71		3.2	3.67		4.45		3.01
1	lug-23	2.66		3.71	4.18	3.01				2.3	2.81
2	lug-23			3.71		3.2	3.67		4.45		3.01
3	lug-23		3.28	3.71		3.2		3.95	4.38		2.97
1	ago-23			3.71	4.14	3.13	3.6		4.34	2.22	2.7
2	ago-23		3.32	3.75			3.71				3.69
3	ago-23			3.71	4.18	3.01			4.63	2.31	
1	ago-23			3.71	4.14	3.13	3.59		4.34	2.23	2.7
2	ago-23		3.32	3.75		3.05	3.71				3.01
3	ago-23			3.71	4.18	3.01		4.02	4.63	2.3	2.81
1	ago-23			3.71	4.14	3.13	3.59		4.34	2.23	2.7
2	ago-23		3.32	3.75		3.01		4.02	4.63	2.3	2.81
3	ago-23			3.71	4.18	3.05	3.71			2.27	2.77
1	set-23		3.2	3.79		2.97					2.73
2	set-23		3.06	3.75		3.05	3.74				2.73
3	set-23			3.75	4.22	2.85	3.41	4.14			2.77
1	set-23		3.2	3.79		2.97		4.1			2.73
2	set-23		3.05	3.75		3.05	3.76				2.73
3	set-23			3.75	4.22	2.85	3.54	4.14			2.77
1	set-23			3.75		2.97		4.14			2.73

Monitoring activity on Fiorenza Node of A4 Highway

2	set-23		3.2	3.79		3.01	3.76			2.73	4.33		
3	set-23		3.05	3.75	4.22	2.85	3.54	4.14		2.73			
1	ott-23		3.36	3.87	4.34	3.08	3.59		2.27		4.3		
2	ott-23	2.56		3.75	4.3			4.02	4.63	2.73	3.67	4.22	
3	ott-23				4.45	3.01	3.71			2.77	3.75	4.41	
1	ott-23		3.36	3.87	4.34	3.08	3.59			3.05		4.3	
2	ott-23			3.75	4.3			4.02	4.63	2.73	3.67	4.22	
3	ott-23			3.63	4.45	3.01	3.71			2.77	3.75	4.41	
1	ott-23		3.04	3.75	4.3	3.09	3.59			3.09		4.3	
2	ott-23			3.75				4.02	4.63	2.77	3.75	4.22	
3	ott-23			3.75		3.01	3.71			2.77		4.14	
1	nov-23	2.53		3.71	4.38		3.48	4.06	4.34	2.27	2.73	3.67	4.41
2	nov-23			3.83		3.01	3.64	3.98		2.31	2.7	3.67	4.3
3	nov-23			3.83	4.41		3.33			2.73	3.67	4.25	
1	nov-23	2.53		3.71	4.38		3.48	4.06	4.34	2.31	2.73	3.63	4.41
2	nov-23			3.83		3.01	3.63			2.27	2.7	3.67	4.3
3	nov-23			3.79		3.33		3.98		2.73	3.67	4.22	
1	nov-23	2.53		3.71	4.38		3.48	4.06	4.34	2.31	2.73	3.67	4.41
2	nov-23			3.83		3.01	3.63			2.27	2.7	3.67	4.3
3	nov-23			3.79				3.98		2.73	3.67	4.26	
1	dic-23			3.79		3.13		4.02	4.65	2.23	2.77	3.6	4.73
2	dic-23			3.75	4.45	3.05		3.91	4.51	2.2	2.7	3.48	4.71
3	dic-23		3.04	3.65		3.01		3.95		2.21	2.77	3.64	4.76
1	dic-23			3.79		3.13		4.02	4.65	2.23	2.77	3.6	4.73
2	dic-23		3.04	3.75	4.45	3.05		3.91		2.2	2.7	3.48	4.73
3	dic-23			3.6		3.01		3.98		2.21	2.77	3.59	4.88
1	dic-23			3.79		3.13		4.02	4.65	2.23	2.77	3.6	4.73
2	dic-23			3.75		3.05	3.59			2.77		4.32	
3	dic-23		3.04	3.79	4.45	3.01		3.98		2.77	3.52	4.3	

3.2.1 Vertical direction (x)

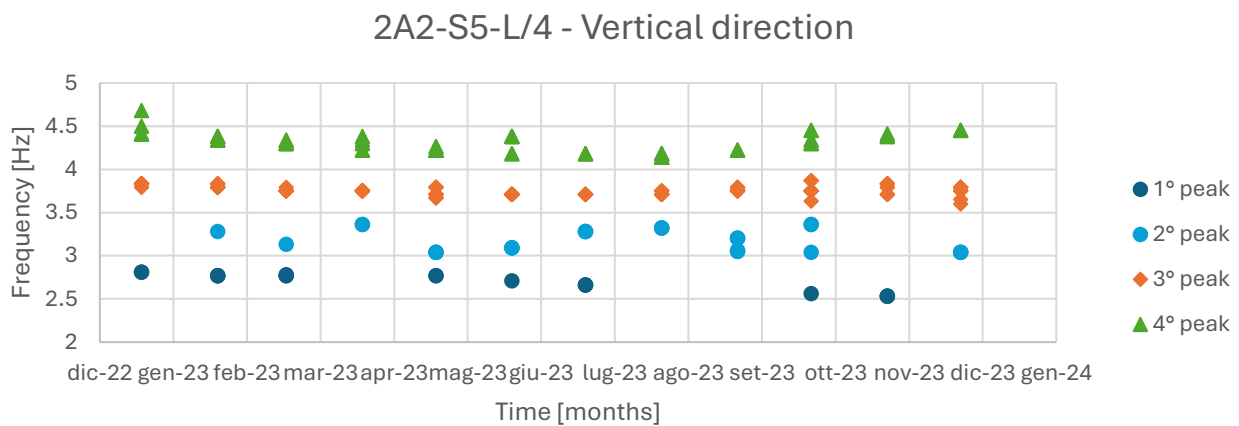

Figure 3-6: 2A2-S4-L/4 - Natural frequencies obtained in vertical direction

3.2.2 Longitudinal direction (y)

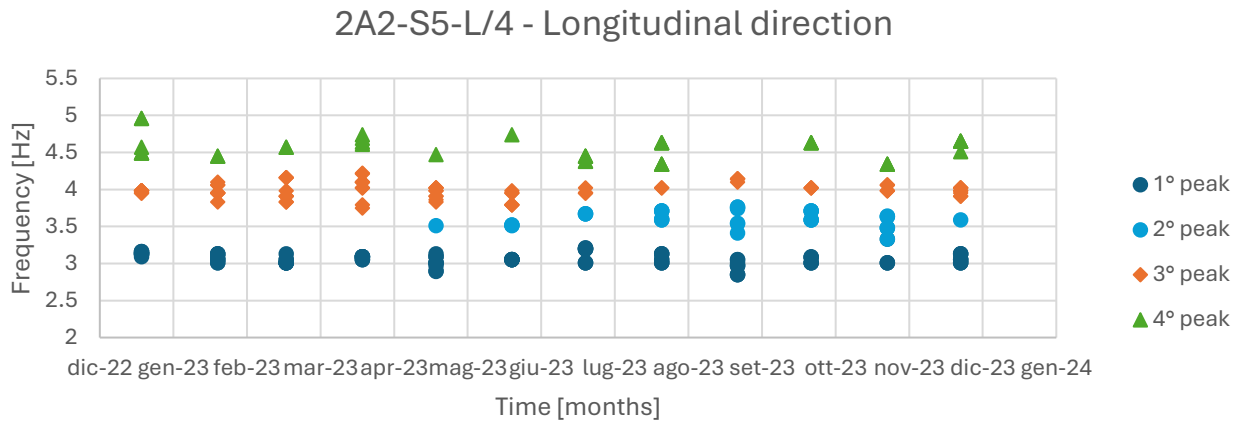

Figure 3-7: 2A2-S4-L/4 - Natural frequencies obtained in longitudinal direction

3.2.3 Transverse direction (z)

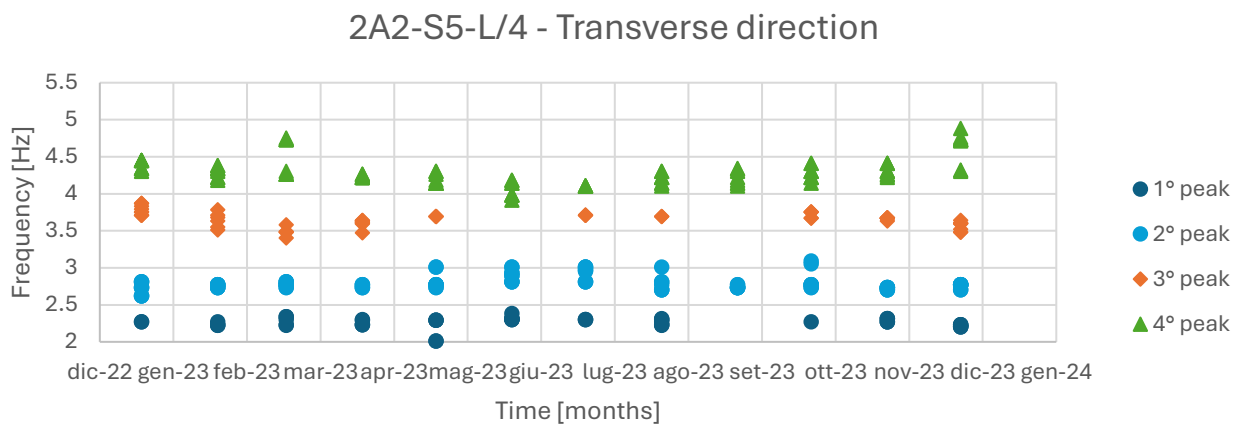

Figure 3-8: 2A2-S4-L/4 - Natural frequencies obtained in transverse direction

3.3 2A2 SP4 L/8 Sensor 31639

All the obtained frequencies have been now classified and represented in such a way to obtain the variation of the values during the year. So, the peaks value has been separated and the representation for the vertical, longitudinal and transverse direction have been obtained.

Table 3-4 2023 natural frequencies [Hz] identified for sensor 31639 – 2A2 SP4 L/8

	Vertical direction				Longitudinal direction				Transverse direction			
	1° peak	2° peak	3° peak	4° peak	1° peak	2° peak	3° peak	4° peak	1° peak	2° peak	3° peak	4° peak
Numerosity	38	16	108	63	93	72	51	40	33	69	45	43
MEAN	2.75	3.22	3.75	4.40	3.03	3.68	4.01	4.49	2.23	2.77	3.73	4.57
SD	0.13	0.09	0.04	0.19	0.10	0.13	0.10	0.21	0.06	0.08	0.17	0.14
C.o.V.	4.6%	2.9%	1.2%	4.4%	3.2%	3.6%	2.5%	4.7%	2.6%	2.7%	4.5%	3.1%
Rating	27%	13%	100%	45%	73%	55%	42%	28%	27%	56%	32%	34%

Monitoring activity on Fiorenza Node of A4 Highway

1	gen-23			3.83	4.44	3.09	3.4	3.95					
2	gen-23	2.85		3.79	4.53	3.09		3.98	4.65				
3	gen-23	2.64		3.83	4.44	3.13		3.98					
1	gen-23	2.85		3.83	4.51	3.08		3.95		2.27	2.62	3.91	
2	gen-23	2.65		3.79	4.51	3.09		3.98	4.65		2.8	3.99	4.63
3	gen-23			3.79	4.38	3.13		3.83			2.73	4.06	4.63
1	gen-23	2.89		3.83		3.13		3.83		2.27	2.62	3.86	
2	gen-23			3.83	4.41	3.09		3.98	4.65		2.73	3.99	4.63
3	gen-23			3.83		3.13		3.95			2.8		4.67
1	feb-23	2.77	3.29	3.78	4.89	3.13		4.02	4.5				
2	feb-23			3.78		3.01		4.06					
3	feb-23	2.86		3.77	4.31	3.05		3.9					
1	feb-23	2.77	3.29	3.79	4.89	3.13		4.02	4.49	2.21	2.73	3.51	
2	feb-23			3.79		3.01		4.06			2.66	3.81	4.63
3	feb-23	2.86		3.77	4.31	3.05		3.95			2.77		4.61
1	feb-23			3.78	4.31	3.13		4.02		2.23	2.73	3.51	
2	feb-23	2.86		3.79		3.09		3.89			2.77		4.65
3	feb-23	2.73	3.29	3.79	4.89	3.01		4.06	4.59		2.77		4.65
1	mar-23		3.31	3.75	4.3	3.01	3.79						
2	mar-23			3.75		3.01		3.91	4.45				
3	mar-23			3.75		3.09	3.83						
1	mar-23		3.31	3.75	4.3	3.01	3.79				2.77	3.63	4.57
2	mar-23			3.75		3.01		3.91	4.45	2.18	2.73		4.73
3	mar-23			3.75		3.05	3.83			2.18	2.81	3.55	
1	mar-23		3.31	3.75	4.3	3.01	3.79			2.19	2.73	3.71	4.73
2	mar-23			3.75		3.01	3.83			2.19	2.77	3.67	4.65
3	mar-23			3.75		3.01		3.9	4.49		2.77	3.67	
1	apr-23			3.75		3.09	3.76	4.1	4.57				
2	apr-23	2.49		3.75		3.05	3.76	4.22					
3	apr-23	2.5		3.71	4.68	3.05	3.72		4.53				
1	apr-23			3.75		3.09	3.79	4.1	4.57		2.77		4.29
2	apr-23			3.75	4.25	3.04	3.75	4.22	4.53	2.24	2.77	3.6	
3	apr-23			3.7		3.04	3.79			2.22	2.77	3.59	4.53
1	apr-23			3.75		3.09	3.75			2.24	2.77	3.6	4.65
2	apr-23			3.75		3.05	3.75	4.22			2.73	3.63	4.61
3	apr-23			3.75	4.3	3.13	3.83		4.57	2.22	2.77	3.59	4.53
1	mag-23			3.75		3.01							
2	mag-23	2.51		3.75		3.09	3.63		4.43				
3	mag-23	2.51		3.75	4.69		3.6	3.98					
1	mag-23	2.79		3.71		3.01	3.63		4.41	2.18	2.77		4.69
2	mag-23			3.75		3.01					2.77		
3	mag-23			3.71	4.33		3.63	4.19		2.3	2.94		4.53
1	mag-23	2.79		3.71		3.01	3.79			2.18	2.77		4.69
2	mag-23			3.71		2.97	3.71				2.73		
3	mag-23			3.79	4.65	3.08	3.63		4.45	2.3	2.77	3.75	
1	giu-23	2.66		3.71	4.59	3.05	3.61	3.98	4.68				

Monitoring activity on Firenze Node of A4 Highway

2	giu-23	2.73		3.71		3.61	4.31						
3	giu-23	2.54		3.71	4.8	3.05							
1	giu-23			3.71		3.05	3.67	3.98	4.68		2.81	3.91	4.61
2	giu-23	2.73		3.71	4.3		3.67		4.31	2.3	2.89		
3	giu-23			3.71	4.84	3.05	3.71				2.93	3.91	
1	giu-23			3.71		3.05	3.67	3.98	4.68		2.81	3.91	
2	giu-23			3.71	4.59		3.67		4.31	2.3	2.93		
3	giu-23	2.77		3.71			3.71			2.3	2.89		4.29
1	lug-23	2.66		3.71	4.19	2.69	3.67		4.45				
2	lug-23	2.62	3.22	3.71	4.26	2.78		3.95					
3	lug-23			3.75	4.22	3.01	3.55	4.07					
1	lug-23	2.66		3.71	4.18	2.78	3.2	3.95			2.85		4.69
2	lug-23			3.71	4.21	2.69			4.45		2.97	4.1	
3	lug-23			3.71		3.01					2.81		
1	lug-23	2.65		3.71	4.18	3.01	3.59				2.85		4.65
2	lug-23			3.71		2.73	3.24	3.67	4.45		2.73	3.63	
3	lug-23			3.78	4.26	2.62	3.2					4.1	
1	ago-23		3.22	3.71	4.18	3.13	3.67		4.39				
2	ago-23			3.71	4.29	3.01	3.71	4.06					
3	ago-23	2.84		3.75	4.61	3.01	3.75						
1	ago-23			3.71	4.18	3.13	3.67		4.39			3.79	
2	ago-23			3.75	4.29	3.01	3.75	4.06		2.3	2.73		
3	ago-23	2.81		3.71	4.61	3.01	3.75				2.85		4.49
1	ago-23			3.71	4.18	3.13	3.67		4.39	2.3	2.73	4.09	4.69
2	ago-23	2.81		3.71	4.57	3.01	3.75				2.73	3.79	4.67
3	ago-23			3.71			3.71			2.3	2.81		
1	set-23	2.94		3.79	4.31	2.97							
2	set-23	2.73		3.75	4.22	3.04	3.71						
3	set-23		3.06	3.75	4.6	2.97	3.68	4.17					
1	set-23		3.06	3.79	4.21	2.97	3.86				2.73	3.63	4.29
2	set-23			3.75		2.97	3.79				2.73	3.67	4.29
3	set-23		3.13	3.75	4.33	3.05		4.14			2.73		4.24
1	set-23		3.06	3.79	4.33	2.97					2.73	3.63	4.24
2	set-23		3.13	3.75	4.41	3.05	3.79			2.01	2.73	3.63	
3	set-23			3.75		2.97	3.86				2.73		
1	ott-23			3.75		3.09							
2	ott-23			3.61	4.57		3.64	4.02	4.65				
3	ott-23	2.81		3.77	4.31	2.97	3.64						
1	ott-23			3.63	4.49	3.08	3.67				2.73	3.67	4.69
2	ott-23			3.75	4.29		3.67	4.02	4.65		3.01		
3	ott-23	2.85		3.82	4.34	3.01	3.67			2.22	2.73	3.75	
1	ott-23			3.75	4.29	3.01	3.67				2.73	3.71	4.69
2	ott-23			3.75	4.29		3.67	4.02	4.65		3.01		
3	ott-23	2.73		3.75		2.97	3.78			2.22	2.77	3.79	4.65
1	nov-23		3.26	3.71	4.26		3.52	4.06	4.39				
2	nov-23	2.91		3.79	4.31	3.01	3.64						
3	nov-23			3.83	4.29			3.98					

Monitoring activity on Fiorenza Node of A4 Highway

1	nov-23		3.26	3.71	4.34		3.52	4.06	3.38		2.73	3.63	4.45
2	nov-23			3.82	4.34	3.01	3.63				2.71	3.67	
3	nov-23			3.79		3.08		3.98		2.26	2.73		4.63
1	nov-23		3.26	3.71	4.34		3.52	4.06	4.38		2.73	3.63	4.31
2	nov-23			3.79		3.01	3.61			2.26	2.73	3.67	
3	nov-23			3.79				3.98			2.73	3.67	4.54
1	dic-23			3.78		3.13		4.02	4.65				
2	dic-23	2.91		3.71	4.45	3.09	3.79		4.53				
3	dic-23			3.6		3.05	3.79						
1	dic-23			3.79		3.13		4.02	4.65	2.26	2.7	3.52	4.64
2	dic-23	2.89		3.71		3.09	3.79		4.45	2.24	2.77	3.6	4.59
3	dic-23			3.64		3.05	3.78			2.24	2.77		
1	dic-23			3.79		3.13		4.02	4.65	2.19	2.77		4.61
2	dic-23			3.79		3.09	3.75			2.22	2.77	3.59	4.59
3	dic-23	2.93		3.71		2.98	3.61			2.22		3.48	4.59

3.3.1 Vertical direction (x)

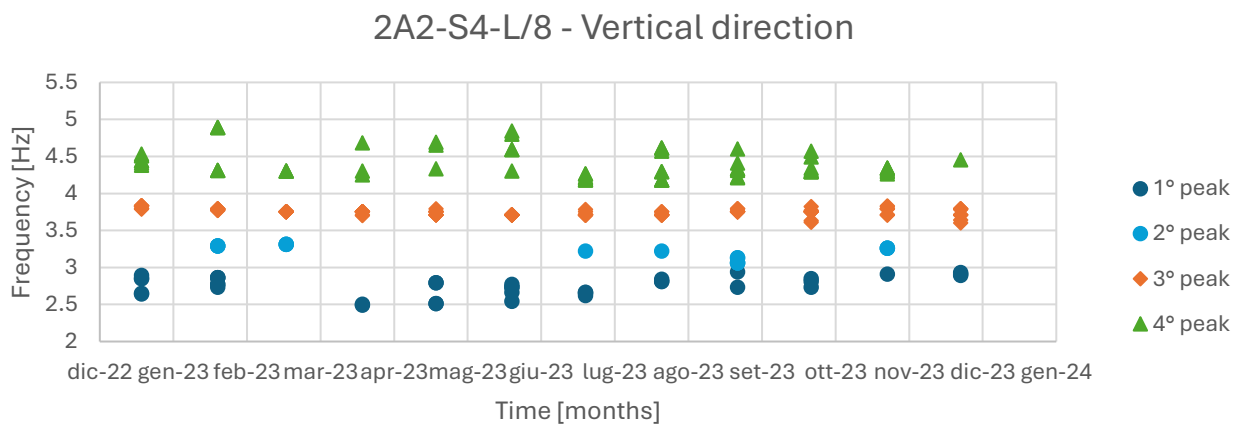

Figure 3-9 : 2A2-S4-L/8 - Natural frequencies obtained in vertical direction

3.3.2 Longitudinal direction (y)

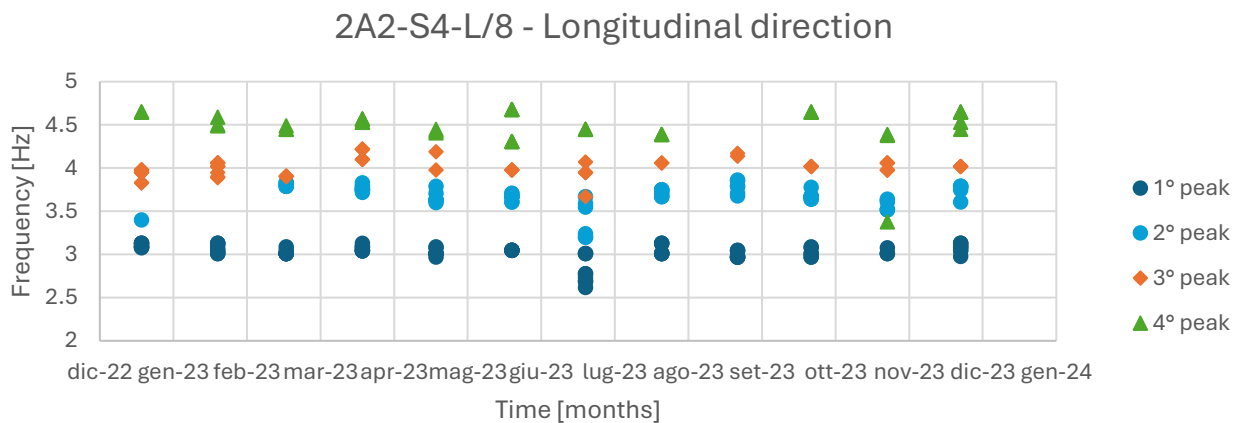

Figure 3-10: 2A2-S4-L/8 - Natural frequencies obtained in longitudinal direction

3.3.3 Transverse direction (z)

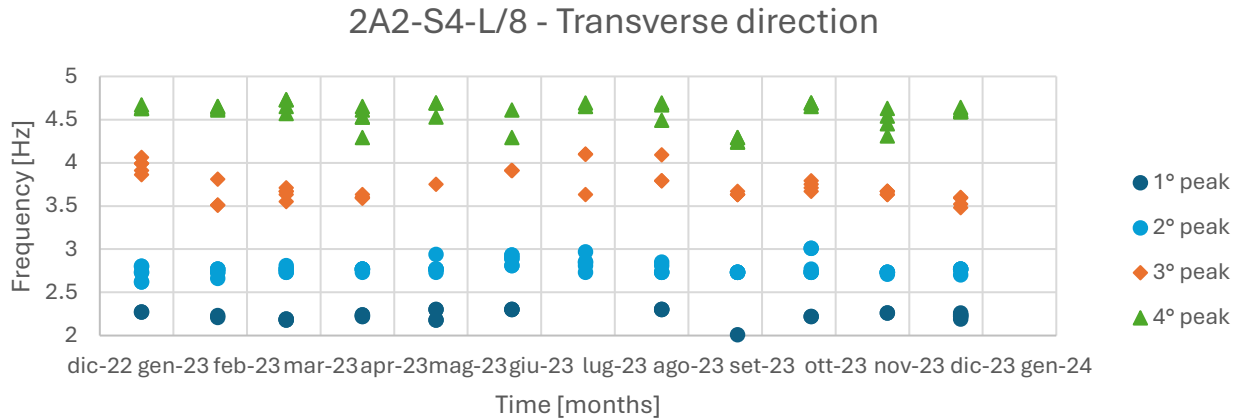

Figure 3-11: 2A2-S4-L/8 - Natural frequencies obtained in transverse direction

3.4 2A2 SP4 Pier Sensor 30D41

All the obtained frequencies have been now classified and represented in such a way to obtain the variation of the values during the year. So, the peaks value has been separated and the representation for the vertical, longitudinal and transverse direction have been obtained.

Table 3-5 2023 natural frequencies [Hz] identified for sensor 30D41 – 2A2 SP4 Pier

	Vertical direction				Longitudinal direction				Transverse direction				
	1° peak	2° peak	3° peak	4° peak	1° peak	2° peak	3° peak	4° peak	1° peak	2° peak	3° peak	4° peak	
Numerosity	106	108	107	108	108	108	108	108	108	108	108	108	
MEAN	2.76	3.67	4.01	4.57	3.03	3.47	4.02	4.55	2.20	2.76	3.66	4.50	
SD	0.10	0.09	0.07	0.15	0.06	0.09	0.08	0.15	0.10	0.08	0.12	0.19	
C.o.V.	3.5%	2.4%	1.7%	3.3%	2.0%	2.5%	2.0%	3.4%	4.4%	3.0%	3.2%	4.2%	
Rating	86%	95%	100%	89%	98%	94%	98%	88%	82%	90%	89%	83%	
1	Jan-23	2.73		4.1	4.69	3.06	3.43	4.02	4.96		2.73	3.59	4.68
2	Jan-23	2.77	3.79			3.03		3.91	4.61	2.19	2.62	3.83	4.76
3	Jan-23	2.62	3.79	4.16			3.43	4.14		1.91	2.77	3.71	4.57
1	Jan-23	2.73		4.1	4.69	3.05	3.46	4.02	4.96		2.73	3.48	4.69
2	Jan-23	2.77	3.73			3.05		3.92	4.61		2.62	3.74	4.77
3	Jan-23	2.62	3.73		4.73	3.05	3.39	4.13		1.99	2.77	3.69	4.69
1	Jan-23	2.81		4.06	4.73	3.09	3.43	4.02	4.96		2.73	3.49	4.69
2	Jan-23	2.62				3.05	3.4	4.13			2.62	3.71	4.73
3	Jan-23	2.73		4.09	4.69	3.05		3.91		2.26	2.77	3.66	4.84
1	Feb-23	2.5	3.71	4.02	4.65	3.09		3.98	4.69		2.5		4.69
2	Feb-23	2.77		4.02	4.53	3.04		4.06	4.65		2.77	3.63	4.65
3	Feb-23	2.77		3.92	4.39	3.06		4.1	4.69		2.77	3.63	
1	Feb-23	2.5	3.51	4.02	4.65	3.13		3.98	4.69		2.5	3.49	4.69

Monitoring activity on Fiorenza Node of A4 Highway

2	Feb-23	2.77	3.79			3.08	4.06	4.69		2.77	3.64	
3	Feb-23	2.77	3.53	4.02	4.53	3.08	3.59	4.14		2.77	3.64	
1	Feb-23	2.5	3.51	4.02	4.65	3.13		3.98	4.69	2.77	3.79	4.69
2	Feb-23	2.77	3.79	4.02	4.53	3.05		4.06	4.65	2.5	3.77	4.69
3	Feb-23	2.77			4.42			4.02	4.65	2.26	2.77	
1	Mar-23	2.73		3.95	4.69	3.01		4.09		2.77	3.49	4.69
2	Mar-23	2.77		3.81	4.65	3.01		3.91	4.49	2.27	2.73	3.81
3	Mar-23	2.73		3.91				4.16		2.7		4.46
1	Mar-23	2.73		3.95	4.69	3.01		4.14		2.77	3.89	4.69
2	Mar-23	2.73		3.95	4.65	3.01		3.95	4.49	2.3	2.73	3.81
3	Mar-23	2.73		3.98		3.05		3.95		2.7		4.49
1	Mar-23	2.73		3.95	4.69	3.01		4.14		2.7	3.46	4.42
2	Mar-23	2.69	3.71			3.05		3.95		2.19	2.77	3.51
3	Mar-23	2.77	3.71			3.01		3.95	4.49	2.22	2.77	3.56
1	Apr-23	2.73		3.98	4.53	3.09		3.98		2.18	2.77	3.63
2	Apr-23	2.77	3.75	4.1		3.09		4.1		2.73	3.67	4.49
3	Apr-23	2.73	3.63			3.05		4.1	4.61	2.22	2.73	3.59
1	Apr-23	2.77	3.75	3.98	4.49	3.09		3.98	4.53	2.19	2.77	3.63
2	Apr-23	2.73	3.68	4.1		3.05		4.1	4.61	2.23	2.77	3.67
3	Apr-23	2.77	3.63	3.95		3.09		4.1		2.73	3.59	4.53
1	Apr-23	2.77	3.63	4.02	4.49	3.05		3.98	4.53	2.19	2.77	3.63
2	Apr-23	2.73	3.55	3.98		3.05		4.1		2.23	2.73	3.59
3	Apr-23	2.77		3.95		3.01		4.06		2.77	3.67	4.53
1	May-23	2.77	3.67	4.02		3.01		4.06		2.77	3.71	4.22
2	May-23	2.77	3.63	4.02	4.53	3.09		4.02	4.53	2.1	2.77	3.63
3	May-23	2.73		4.1		3.01	3.51	4.14		2.73	3.67	
1	May-23	2.77	3.63	4.02		3.09		4.02	4.53	2.77	3.67	4.22
2	May-23	2.77	3.63	4.02	4.53	3.01	3.51	4.14		2.1	2.77	3.63
3	May-23	2.73		4.1		3.01		4.06		2.73	3.63	
1	May-23	2.77	3.63	4.02		3.01		4.06		2.77	3.71	4.22
2	May-23	2.77	3.63	4.02	4.53	3.09		4.02	4.53	2.77	3.75	
3	May-23	2.77	3.74			3.01	3.51	4.09		2.73	3.67	4.19
1	Jun-23	2.81		4.02		3.05		3.94		2.3	2.79	3.79
2	Jun-23	2.93	3.69		4.68		3.49		4.29	2.3	2.83	3.71
3	Jun-23	3.01	3.71	4.06				3.91	4.5	2.83		4.27
1	Jun-23	2.81		4.02		3.05		3.89		2.3	2.81	3.79
2	Jun-23	2.92	3.49	3.96	4.65		3.48		4.29	2.3	2.84	3.71
3	Jun-23		3.67	4.06				3.91	4.49	2.71		4.31
1	Jun-23	2.81		4.02		3.05		3.89		2.3	2.81	3.79
2	Jun-23	2.92		3.89			3.48	4.09	4.29	2.3	2.84	
3	Jun-23	2.93		3.91	4.65					2.85		4.45
1	Jul-23	2.81			4.44		3.33	3.98	4.49	2.81	3.79	4.31
2	Jul-23	2.81		4.14		2.73	3.29	4.14		2.91	3.79	4.24
3	Jul-23	3.01		3.95		3.01		4.07	4.42	2.85		

Monitoring activity on Fiorenza Node of A4 Highway

1	Jul-23		3.81	4.42		3.32	3.98	4.45	1.91	2.81	3.79	4.31	
2	Jul-23	3.01		3.95		2.79	3.26	3.84	4.41		2.89	4	
3	Jul-23		3.81	4.09		3.01		4.41		2.91	3.79	4.21	
1	Jul-23	2.81				3.01		4.06	4.45	2.81	3.79	4.34	
2	Jul-23	3.01		3.95	4.42	3.05			4.34	3.01	3.75	4.24	
3	Jul-23	2.85			4.45	2.84	3.26	3.84	4.41	2.1	2.85	3.71	4.26
1	Aug-23	2.71		3.98	4.34		3.55	3.95		2.21	2.69	3.53	4.57
2	Aug-23			3.91	4.46	3.05		4.1		2.21	2.71	3.69	4.42
3	Aug-23	2.77		3.98	4.81	3.01		3.95	4.65		2.77		4.29
1	Aug-23	2.7		3.94	4.45		3.51	3.95		2.21	2.7	3.51	4.57
2	Aug-23	2.7		3.98	4.31	3.05		4.1			2.7	3.61	4.39
3	Aug-23	2.77	3.74		4.29	3.01		3.95	4.61	2.21	2.77	3.51	
1	Aug-23	2.7	3.52	3.91	4.49		3.55	3.95		2.21	2.7	3.75	4.57
2	Aug-23	2.7		3.98	4.36	3.05		4.1			2.73		4.33
3	Aug-23	2.77	3.75		4.8	3.01		3.95	4.61	2.16	2.77		4.76
1	Sep-23	2.73		3.98		2.97		3.95			2.73		4.21
2	Sep-23	2.73		3.95		3.05					2.73	3.91	
3	Sep-23	2.81				3.01	3.49		4.29		2.84	3.86	
1	Sep-23	2.73		3.98		2.97		3.95			2.73		4.21
2	Sep-23	2.73		3.98		3.01		3.89			2.73	3.91	
3	Sep-23	2.81		3.91		3.01	3.48		4.29		2.84	3.86	
1	Sep-23	2.73		3.98		2.97		3.95			2.73		4.21
2	Sep-23	2.7		3.95	4.57	3.01		3.87			2.73		
3	Sep-23	2.77		3.98	4.57	2.97	3.51		4.29		2.73		
1	Oct-23	2.77		3.98	4.32	3.09	3.55		4.38		2.73	3.54	4.69
2	Oct-23	2.73		3.95				3.98			3.01	3.63	4.49
3	Oct-23	3.04		4.02	4.45	3.01		3.96	4.45		2.73	3.87	4.61
1	Oct-23	2.73		3.95	4.32	3.09	3.55		4.34		2.73	3.63	4.41
2	Oct-23	2.73		3.98				3.98	4.45		3.01		4.45
3	Oct-23	3.04		4.02	4.45	3.01		3.9	4.45		2.73	3.87	4.61
1	Oct-23	2.73	3.63	3.95		3.05	3.55	3.98	4.34		3.01	3.63	4.45
2	Oct-23	2.73	3.67	3.98	4.32				4.49		2.73	3.63	4.41
3	Oct-23	3.04		4.02	4.45	3.01		3.91	4.49		2.73		4.61
1	Nov-23	2.73	3.71	4.06	4.53	3.05	3.49	4.06	4.65	2.18	2.73	3.59	4.49
2	Nov-23	2.7	3.67	4.02			3.32	4.02			2.66	3.63	4.57
3	Nov-23	2.73		3.92	4.57	3.01	3.59				2.73	3.55	4.68
1	Nov-23	2.73	3.71	4.06	4.53	3.09	3.48	4.06	4.65	2.22	2.73	3.59	4.49
2	Nov-23	2.73	3.67	4.02		3.01	3.54	4.11			2.66	3.63	4.57
3	Nov-23	2.7			4.57	3.09		4.11	4.61		2.77	3.55	4.38
1	Nov-23	2.73	3.71	4.06	4.53	3.05	3.48	4.06	4.65		2.66	3.63	4.57
2	Nov-23	2.7	3.67	4.02				4.02		2.22	2.73	3.6	4.49
3	Nov-23	2.7				3.01	3.54		4.53		2.7	3.51	
1	Dec-23	2.77	3.75	4.09	4.73	3.09	3.52	4.02	4.61		2.73	3.44	4.8
2	Dec-23	2.73	3.52	4.13	4.8			4.06			2.77	3.51	4.8

3	Dec-23	2.73		4.02		3.01	3.52	4.1	4.61		2.73		4.61
1	Dec-23	2.77	3.75	4.1	4.73	3.09	3.52	4.02	4.61		2.7	3.44	4.8
2	Dec-23	2.73	3.52	4.14	4.81			4.06	4.65		2.77	3.55	4.81
3	Dec-23	2.73		4.06	4.96	3.01	3.48	4.06	4.61		2.73		4.61
1	Dec-23	2.77	3.75	4.1	4.73	3.09	3.52	4.02	4.61		2.7	3.4	4.81
2	Dec-23	2.73	3.52	4.14	4.8	3.06		4.1	4.73		2.77	3.61	
3	Dec-23	2.77			4.57	3.06		4.1	4.69	2.19	2.77		

3.4.1 Vertical direction (x)

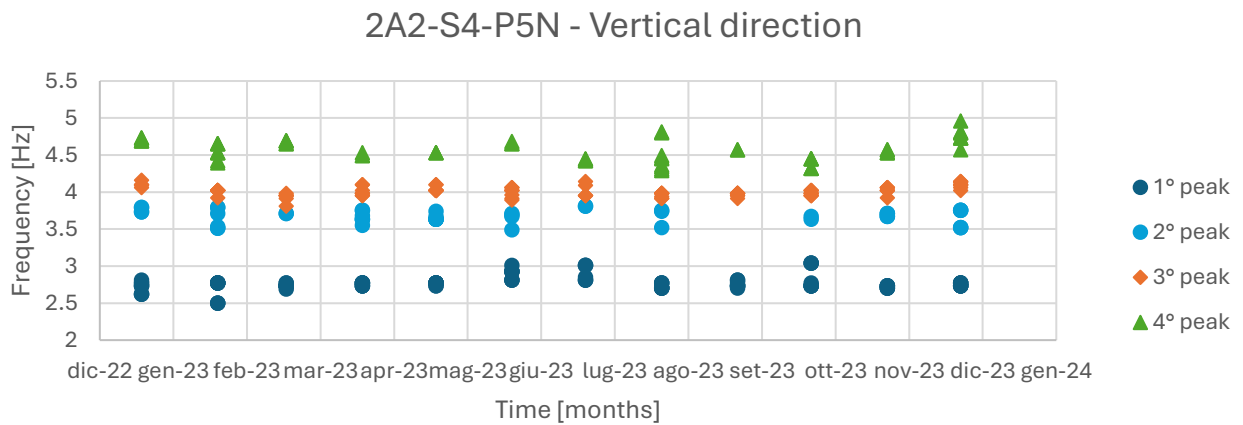

Figure 3-12: 2A2-S4-P5N - Natural frequencies obtained in vertical direction

3.4.2 Longitudinal direction (y)

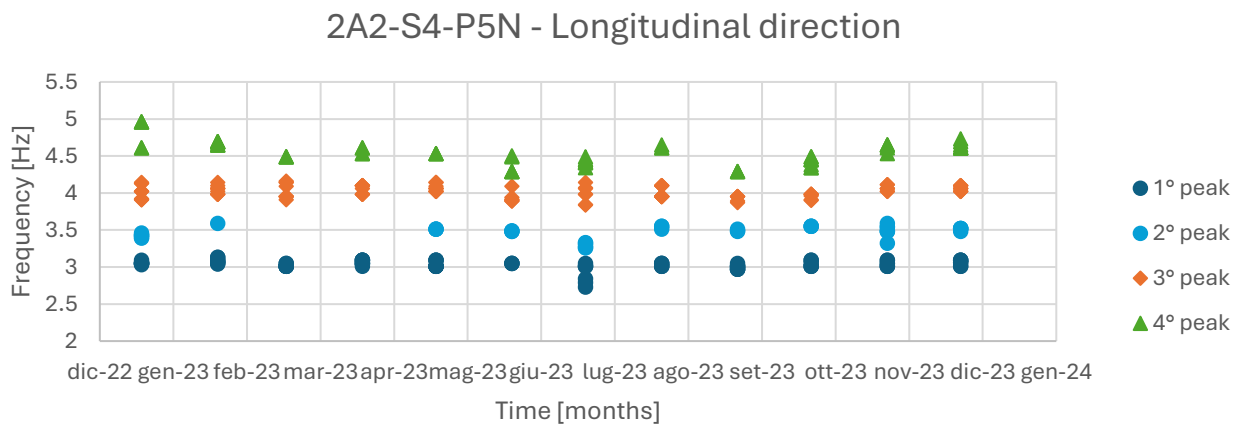

Figure 3-13 : 2A2-S4-P5N - Natural frequencies obtained in longitudinal direction

3.4.3 Transverse direction (z)

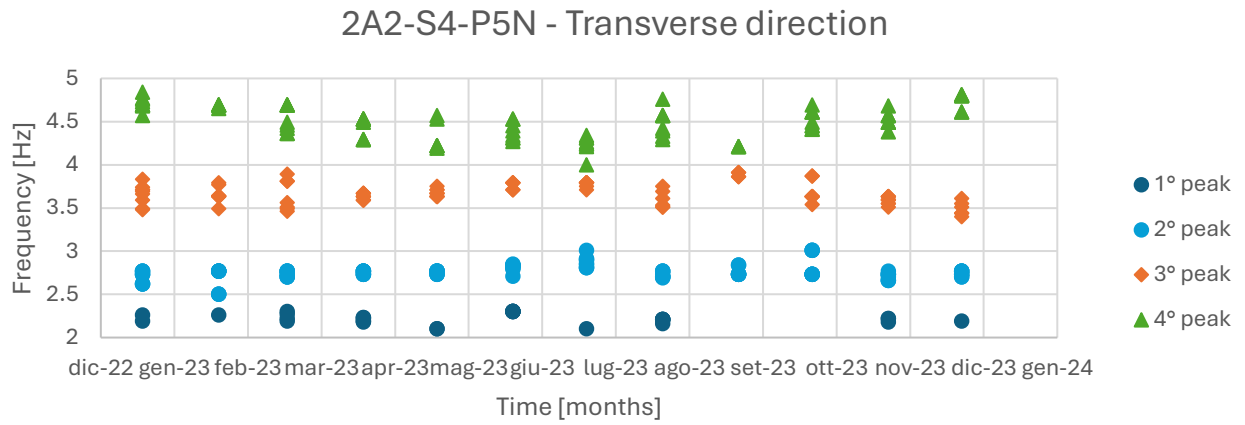

Figure 3-14 : 2A2-S4-P5N - Natural frequencies obtained in transverse direction

4. Bridge 2A2 deck 5

The Bridge 2A2 counts 2 monitored decks: span 4 and span 5 (see Figure 4-1).

On each deck, 4 sensors are present: one in the midspan ($L/2$), one at $L/4$ of the span, one at $L/8$ of the span and the last one near the pier.

The sensors present on deck number 5 are:

- 2B7E4 – situated in the midspan;
- 3187F – situated at a distance of $L/4$ of the deck;
- 2B988 – situated at a distance of $L/8$ of the deck;
- 2C1EA – situated on the pier.

Monitored deck

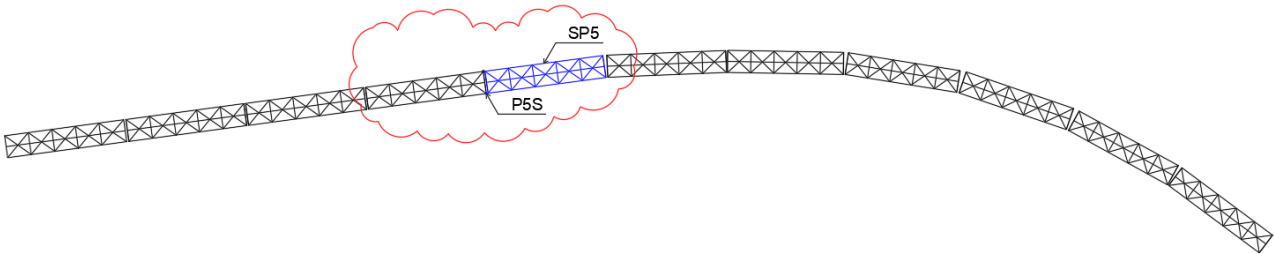

Figure 4-1 Deck 5 of 2A2 bridge

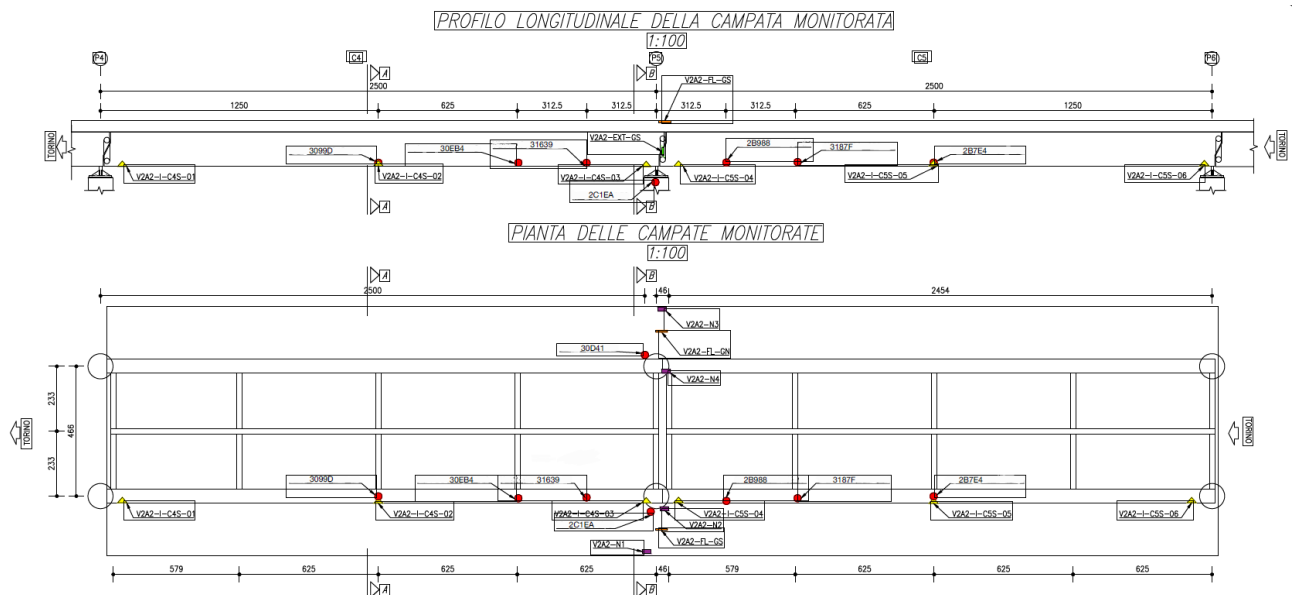

Figure 4-2 Sensor positions on deck 4 and 5 of 2A2 bridge

All the accelerograms registered at scheduled times (every 6 hours) and long 102s have been analyzed and the results are represented in the following Annexes:

- Annex 5 – Sensor 2C1EA
- Annex 6 – Sensor 2B7E4
- Annex 7 – Sensor 3187F
- Annex 8 – Sensor 2B988

The mean frequencies values identified for this deck are presented in Table 4-1.

Table 4-1 2023 Average natural frequencies [Hz] identified for 2A2 deck 5

Direction	Frequency	L/2	L/4	L/8	Pier
Vertical	1 st	2.65	2.72	2.77	2.76
	2 nd	3.34	3.44	3.41	3.66
	3 rd	4.01	4.02	4.01	4.09
	4 th	4.63	4.62	4.61	4.66
Longitudinal	1 st	3.05	3.05	3.03	3.04
	2 nd	3.53	3.47	3.48	3.57
	3 rd	3.99	4.01	4.03	4.02
	4 th	4.54	4.61	4.60	4.63
Transverse	1 st	2.33	2.24	2.09	2.17
	2 nd	2.77	2.76	2.75	2.77
	3 rd	3.79	3.71	3.76	3.72
	4 th	4.60	4.61	4.57	4.54

4.1 2A2 SP5 L/2 Sensor 2B7E4

The natural frequencies have been now classified and represented in such a way to obtain the variation of the values during the year. So, each peak value has been identified and the following representation for the vertical, longitudinal and transverse direction have been obtained.

Table 4-2 2023 natural frequencies [Hz] identified for sensor 2B7E4 – 2A2 SP5 L/2

	Vertical direction				Longitudinal direction				Transverse direction			
	1° peak	2° peak	3° peak	4° peak	1° peak	2° peak	3° peak	4° peak	1° peak	2° peak	3° peak	4° peak
Numerosity	21	22	104	104	100	25	100	12	3	99	52	108
MEAN	2.65	3.34	4.01	4.63	3.05	3.53	3.99	4.54	2.33	2.77	3.79	4.60
SD	0.14	0.11	0.07	0.10	0.08	0.13	0.14	0.15	0.00	0.11	0.27	0.09
C.o.V.	5.3%	3.4%	1.9%	2.1%	2.5%	3.6%	3.4%	3.4%	0.0%	4.0%	7.2%	1.9%
Rating	15%	18%	97%	95%	88%	20%	82%	10%	3%	78%	33%	100%
1 gen-23		3.27	4.02	4.73	3.13		3.95			2.66	4.01	4.77
2 gen-23			4.14	4.73	3.09	3.41	3.99			2.73	3.98	4.77
3 gen-23			4.06	4.77	3.13		3.91			2.81		4.73
1 gen-23		3.27	4.02	4.73	3.13		3.95			2.66	4.01	4.77
2 gen-23			4.14	4.73	3.09		3.91			2.73	3.98	4.77
3 gen-23			4.06	4.8	3.13	3.41	3.98			2.81		4.73
1 gen-23		3.27	4.02	4.77	3.13		3.95			2.66	4.01	4.77
2 gen-23			4.14	4.8	3.13		3.91			2.85		4.73
3 gen-23			4.14	4.77	3.13		3.98			2.77		4.77
1 feb-23	2.69		4.02	4.77	3.13		3.95			2.5	3.43	4.69
2 feb-23			4.18	4.73	3.01		4.02			2.7	3.43	4.73
3 feb-23			4.06	4.77	3.05		3.95			2.77	3.36	4.69
1 feb-23	2.89		4.02	4.77	3.13		3.95			2.5	3.43	4.69
2 feb-23			4.18	4.73	3.01		3.95			2.7	3.43	4.69
3 feb-23			4.1	4.69	3.05		4.06			2.77	3.46	4.73
1 feb-23			4.18	4.73	3.13		3.95			2.69	3.43	4.69

Monitoring activity on Fiorenza Node of A4 Highway

2	feb-23	2.89		4.02	4.77	3.09		3.87		2.5	3.43	4.69
3	feb-23			4.1	4.69	3.05		3.95		2.77	3.36	4.73
1	mar-23	2.67		3.91	4.65	3.01		4.14		2.33		4.53
2	mar-23	2.54		3.95	4.65	3.01		3.95		3.05	3.69	4.57
3	mar-23		3.52	4.1	4.65	3.09		3.91		3.01		4.61
1	mar-23	2.67		3.91	4.65	3.01		4.14		2.33		4.53
2	mar-23	2.54		3.95	4.65	3.05		3.91		3.01		4.49
3	mar-23		3.52	4.1	4.65	3.01		3.83		3.05		4.57
1	mar-23	2.54		3.95	4.65	3.01		4.18		3.01		4.61
2	mar-23	2.67		3.91	4.65	3.05		3.83		2.33		4.53
3	mar-23		3.52	4.1	4.65	3.01		3.91		2.7		4.65
1	apr-23			4.06	4.65	2.97		4.06		2.77		4.61
2	apr-23			3.87	4.57	3.01		3.87		2.73		4.61
3	apr-23			4.1	4.69	3.05		3.83		2.73	3.22	4.65
1	apr-23			4.06	4.65	2.97		4.06		2.77		4.61
2	apr-23			3.87	4.57	3.01		3.87		2.77		4.61
3	apr-23			4.06	4.61	3.05		3.83		2.73	3.22	4.65
1	apr-23			4.06	4.65	3.09		4.06		2.77		4.61
2	apr-23			3.87	4.61	3.01		3.87		2.81		4.57
3	apr-23			4.1	4.69	3.09		3.95		2.73	3.22	4.65
1	mag-23			4.02	4.53	3.01		4.02		2.77	3.56	4.53
2	mag-23	2.72		3.98	4.49	3.13		3.79		2.66		4.49
3	mag-23			3.98	4.69	2.85	3.52	4.02		2.81		4.61
1	mag-23	2.72		3.98	4.49	3.01		4.02		2.77	3.56	4.53
2	mag-23			4.02	4.53	3.13		4.02		2.66		4.49
3	mag-23			3.98	4.73	2.81	3.53	3.79		2.81		4.61
1	mag-23			4.02	4.53	3.01		4.02		2.62		4.49
2	mag-23	2.72		3.98	4.49	3.13		3.79		2.77	3.56	4.53
3	mag-23			3.98		2.81	3.53	4.02		2.77		4.61
1	giu-23			3.95	4.65	3.05		3.95		2.81	4.02	4.52
2	giu-23			3.95	4.57		3.54	4.29		2.89	4.06	4.48
3	giu-23			4.06	4.57			3.87		2.77	3.98	4.52
1	giu-23			3.95	4.65	3.05		3.95		2.81	4.02	4.5
2	giu-23			3.98	4.57		3.54	4.3		2.89	4.06	4.48
3	giu-23			4.06	4.57			4.1		2.77	3.98	4.52
1	giu-23			3.95	4.65	3.05		3.95		2.93	4.06	4.48
2	giu-23			3.95	4.57	3.05		3.83		2.81	4.02	4.52
3	giu-23			4.02	4.57		3.54	4.3		2.77	3.98	4.52
1	lug-23	2.51	3.27	3.91	4.45	3.01		4.1	4.34	2.73		4.45
2	lug-23		3.27	3.95	4.53	3.2		3.95		2.73	4.01	4.53
3	lug-23	2.46			4.45	3.01		4.14	4.45	2.85		4.53
1	lug-23	2.51	3.27	3.91	4.45	3.01		4.1	4.34	2.73		4.45
2	lug-23	2.46		4.05	4.57	3.2		3.95		2.77	4.01	4.53
3	lug-23		3.27	3.95		3.2		4.45		2.85		4.53
1	lug-23			3.98	4.45	3.01		4.1	4.34	2.85		4.53
2	lug-23	2.51	3.27	3.91	4.49	3.2		4.34		2.73	4.01	4.53
3	lug-23	2.46			4.45	3.2		4.45		2.77		4.45

Monitoring activity on Fiorenza Node of A4 Highway

1	ago-23		3.26	3.95	4.49	3.13	3.55	3.95		2.7	3.95	4.49
2	ago-23			4.06	4.75	3.01		3.86		2.69	3.95	4.57
3	ago-23			3.95	4.49	3.01	3.48	4.1		2.7	3.87	4.53
1	ago-23		3.26	3.95	4.49	3.13	3.55	3.95		2.7	3.95	4.49
2	ago-23			4.06	4.77	3.01		3.95		2.7	3.98	4.57
3	ago-23			3.95	4.49	3.01	3.48	4.1		2.7	3.91	4.53
1	ago-23		3.26	3.95	4.49	3.13	3.55	3.95		2.73	3.95	4.49
2	ago-23			4.06	4.77	3.01		3.91		2.7	3.98	4.57
3	ago-23			3.98	4.92	3.01	3.48	4.1		2.73	3.91	4.53
1	set-23			3.98	4.53	2.97	3.52			2.73	3.56	4.53
2	set-23		3.48	3.95	4.61	3.01		3.87		2.89		4.53
3	set-23	2.81		4.06	4.61	2.89	3.4			2.7		4.57
1	set-23			3.98	4.53	2.97		3.95		2.73	3.56	4.5
2	set-23		3.48	3.95	4.61	3.01		3.87		2.7		4.53
3	set-23	2.81		4.06	4.61	2.89		4.1		2.89		4.57
1	set-23		3.48	3.95	4.61	2.97		3.95		2.73	3.56	4.49
2	set-23	2.81		3.98	4.53	3.01		3.87		2.7		4.53
3	set-23			4.02	4.61	2.89		4.14		2.93		4.57
1	ott-23			3.91	4.61	3.09	3.63			3.09		4.65
2	ott-23		3.2	3.91	4.65	3.01		4.02				4.65
3	ott-23		3.2	4.06	4.69	3.01		3.75			4.02	4.61
1	ott-23			3.91	4.61	3.09	3.59			3.09		4.69
2	ott-23		3.2	4.02	4.57	3.01	3.71					4.65
3	ott-23			4.06	4.69	3.01	4.02				4.02	4.61
1	ott-23			3.91	4.61	3.09	3.59			3.09		4.69
2	ott-23			4.02	4.61	2.97		4.02			4.02	4.61
3	ott-23			3.95	4.65	3.01		3.75				4.65
1	nov-23			4.02	4.61	3.13	3.48	4.57		2.7		4.61
2	nov-23			3.91	4.65	3.01		3.79		2.7		4.65
3	nov-23			3.87	4.57	3.13		3.87		2.73		4.73
1	nov-23			4.02	4.61		3.48	4.05	4.57	2.7		4.61
2	nov-23				4.65	3.01		3.79		2.7		4.61
3	nov-23			3.98	4.65	3.13		3.87		2.66		4.65
1	nov-23			4.02	4.61	3.01		3.79		2.7		4.61
2	nov-23				4.65		3.48	4.06	4.57	2.7		4.65
3	nov-23			4.14			3.32	3.98		2.7		4.65
1	dic-23			3.98	4.69	3.09		3.98	4.76	2.73	3.92	4.73
2	dic-23			3.95	4.73	3.01		4.06		2.73		4.65
3	dic-23		3.42	4.06	4.61	3.05		3.95	4.5	2.73	3.94	4.73
1	dic-23			3.98	4.69	3.09		3.98	4.76	2.73	3.94	4.73
2	dic-23			3.95	4.73	3.05		3.95	4.5	2.73		4.65
3	dic-23		3.42	4.1	4.57	3.05		4.06		2.73		4.77
1	dic-23			3.98	4.69	3.09		3.98	4.76	2.73		4.65
2	dic-23			3.95	4.73	3.09		4.14		2.77		4.69
3	dic-23			4.14		3.13		4.1		2.73	3.92	4.73

4.1.1 Vertical direction (x)

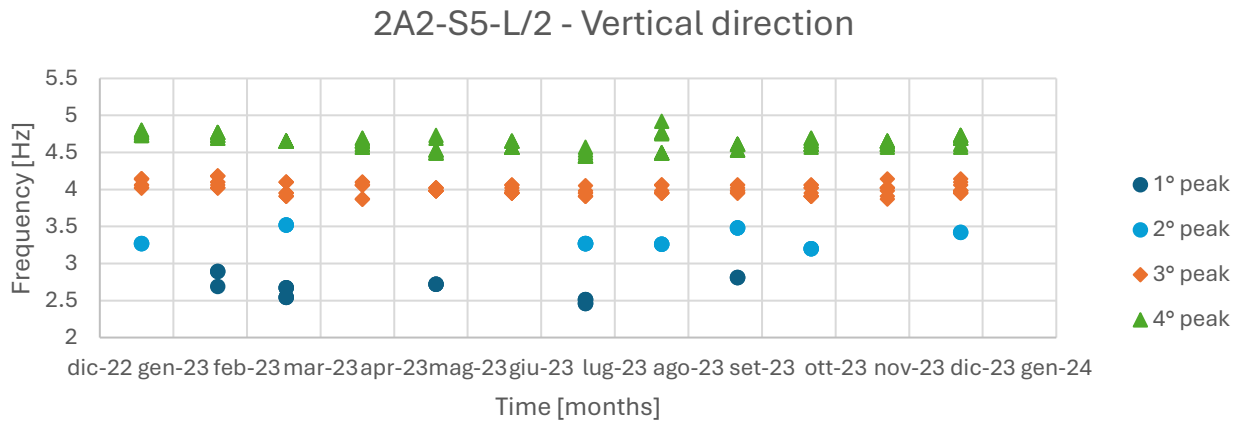

Figure 4-3: 2A2-S5-L/2 - Natural frequencies obtained in vertical direction

4.1.2 Longitudinal direction (y)

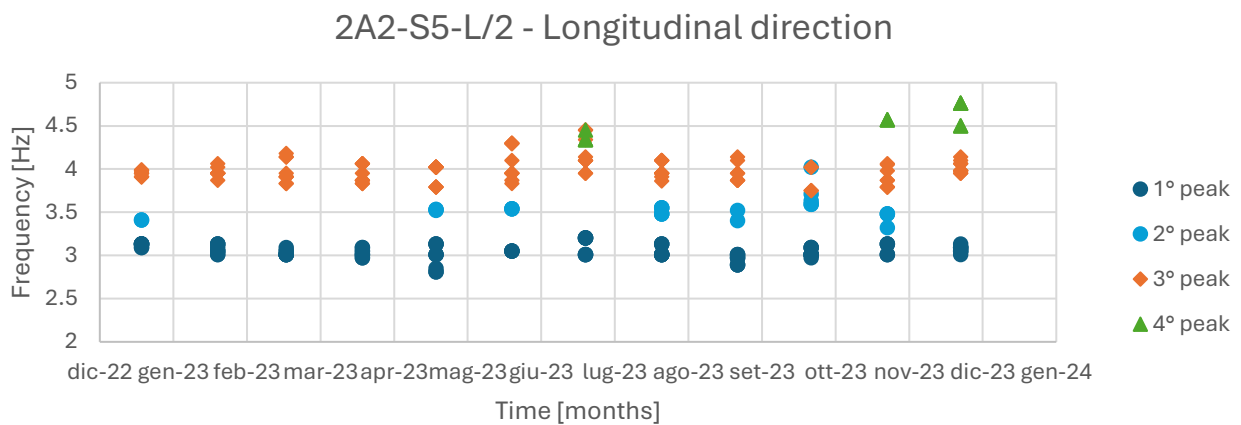

Figure 4-4: 2A2-S5-L/2 - Natural frequencies obtained in longitudinal direction

4.1.3 Transverse direction (z)

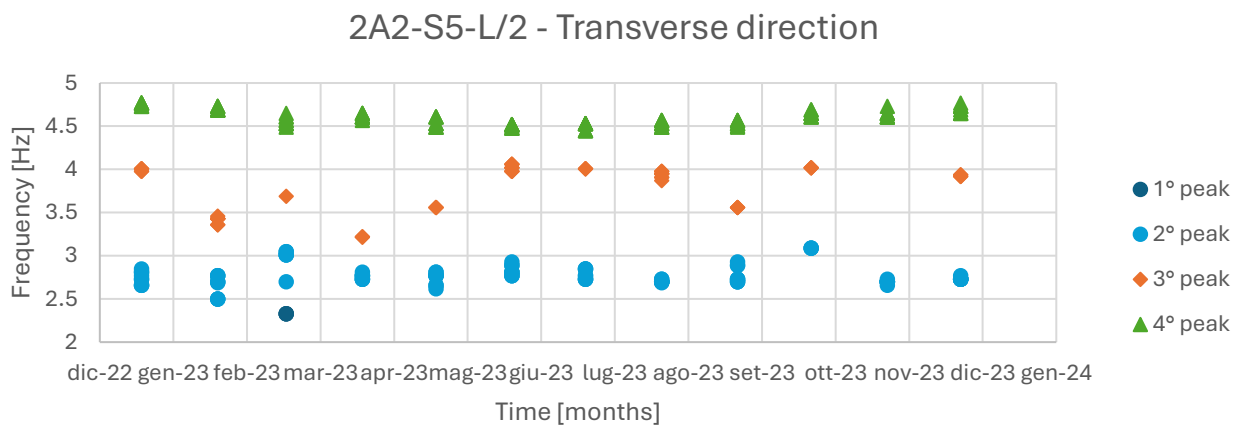

Figure 4-5: 2A2-S5-L/2 - Natural frequencies obtained in transverse direction

4.2 2A2 SP5 L/4 Sensor 3187F

The natural frequencies have been now classified and represented in such a way to obtain the variation of the values during the year. So, each peak value has been identified and the following representation for the vertical, longitudinal and transverse direction have been obtained.

Table 4-3 2023 natural frequencies [Hz] identified for sensor 3187F – 2A2 SP5 L/4

	Vertical direction				Longitudinal direction				Transverse direction			
	1° peak	2° peak	3° peak	4° peak	1° peak	2° peak	3° peak	4° peak	1° peak	2° peak	3° peak	4° peak
Numerosity	27	29	106	106	96	31	104	56	9	108	65	107
MEAN	2.72	3.44	4.02	4.62	3.05	3.47	4.01	4.61	2.24	2.76	3.71	4.61
SD	0.25	0.10	0.08	0.11	0.07	0.11	0.11	0.12	0.03	0.11	0.21	0.09
C.o.V.	9.1%	2.9%	2.0%	2.4%	2.2%	3.2%	2.7%	2.6%	1.5%	3.9%	5.7%	2.0%
Rating	16%	25%	99%	95%	88%	26%	92%	50%	9%	87%	46%	100%
1 gen-23		3.42	4.02	4.77	3.13		3.91	4.63		2.73	3.41	4.77
2 gen-23			4.14	4.8	3.05	3.41	4.02	4.63	2.29	2.58	3.28	
3 gen-23			4.06	4.77	3.09	3.36	4.22			2.83	3.36	4.77
1 gen-23		3.46	4.02	4.77	3.13		3.91	4.63		2.73	3.41	4.77
2 gen-23			4.06	4.77	3.05	3.41	4.02	4.63	2.29	2.58	3.28	4.77
3 gen-23			4.14	4.77	3.05	3.36	4.22			2.77		4.73
1 gen-23		3.46	4.02	4.77	3.13		3.91	4.66	2.29	2.58	3.28	4.77
2 gen-23			4.14		3.09		4.22			2.73	3.41	4.77
3 gen-23			4.14		3.16		3.98			2.77		4.77
1 feb-23	2.66		4.02	4.73	3.13		3.95	4.73		2.5	4.01	4.73
2 feb-23			4.18	4.73	3.01		4.06	4.78		2.73		4.69
3 feb-23			4.18	4.77	3.05		3.95	4.66		2.77	4.03	4.69
1 feb-23	2.66		4.02	4.77	3.13		3.95	4.73		2.5	4.01	4.73
2 feb-23			4.18	4.73	3.05		3.95	4.66		2.73		4.69
3 feb-23			4.18	4.77	3.01		4.06	4.78		2.77	4.03	4.69
1 feb-23	2.66		4.02	4.73	3.13		3.95	4.69		2.73		4.69
2 feb-23			4.18	4.73	3.09		3.87			2.5	4.01	4.73
3 feb-23			4.1	4.69	3.05		3.95	4.59		2.77	4.03	4.69
1 mar-23	2.41	3.41	3.95	4.65	3.01		4.18			2.73	3.83	4.65
2 mar-23	2.49		3.95	4.65	3.01		3.91	4.62		2.73	3.81	4.61
3 mar-23		3.47	4.1	4.65	3.05		4.22			2.73	3.74	4.57
1 mar-23	2.41	3.41	3.95	4.65	3.01		4.18			2.73	3.83	4.65
2 mar-23	2.49		3.95	4.65	3.01		3.91	4.62		2.73	3.81	4.61
3 mar-23		3.47	4.1	4.65	3.05		3.91	4.62		2.73	3.74	4.57
1 mar-23	2.49		3.95	4.65	3.01		4.14			2.7	4.02	4.65
2 mar-23	2.41	3.41	3.95	4.61	3.01		3.91	4.62		2.77		4.61
3 mar-23		3.47	4.1	4.65	3.05		3.87	4.62		3.01	3.68	4.61
1 apr-23		3.63	4.06	4.61	3.09		4.1	4.61		2.77	3.61	4.57
2 apr-23			3.95	4.61	3.13		4.06	4.48	2.21	2.73	3.61	4.61
3 apr-23			4.02	4.61	3.05		3.98	4.61	2.23	2.73	3.54	4.65
1 apr-23			4.02	4.61	3.09		4.1	4.61		2.73	3.61	4.57
2 apr-23			4.02	4.61	3.05		4.02	4.48	2.23	2.77	3.61	4.61

Monitoring activity on Fiorenza Node of A4 Highway

3	apr-23		3.63	4.06	4.61	3.13		3.98	4.61	2.21	2.73	3.54	4.65
1	apr-23		3.63	4.06	4.61	3.13		3.98	4.61	2.21	2.77		4.61
2	apr-23			3.87	4.61	3.09		4.1	4.61		2.73	3.54	4.57
3	apr-23			4.06	4.61	3.09		4.02	4.67	2.23	2.81	3.61	4.57
1	mag-23	2.91		3.98	4.53	3.01		3.98			2.73		4.53
2	mag-23			4.06	4.49	3.16		3.95			2.73	3.64	4.49
3	mag-23			3.95	4.53	3.05	3.51	4.1	4.54		2.54		4.65
1	mag-23	2.91		3.98	4.53	3.01		3.95			2.77		4.53
2	mag-23			4.06	4.49	3.16		3.95			2.73	3.64	4.49
3	mag-23			3.98	4.73	2.77	3.51	4.06	4.54		3.01		4.65
1	mag-23	2.91		3.98	4.53	3.01		3.98			2.77		4.53
2	mag-23			4.06	4.49	3.2		3.95			2.73	3.64	4.49
3	mag-23			3.98	4.92	3.05		3.91			3.01		4.61
1	giu-23			3.95	4.73	3.05		3.95	4.67		2.85	3.74	4.57
2	giu-23			3.98	4.57		3.44	4.26			2.7	3.74	4.53
3	giu-23	3.56		4.02	4.57	3.05		3.83	4.59		2.9		4.53
1	giu-23			3.95	4.69	3.05		3.95	4.67		2.85	3.74	4.57
2	giu-23			3.98	4.57		3.44	4.22			2.7	3.74	4.53
3	giu-23			3.98	4.57	3.05		3.83	4.59		2.89		4.53
1	giu-23			3.95	4.73	3.05		3.95	4.67		2.89	3.74	4.53
2	giu-23			3.98	4.57	3.05		3.79	4.59		2.89	3.74	4.57
3	giu-23	3.56		3.98	4.57		3.48	4.22			2.81		4.57
1	lug-23	2.49	3.26	4.06	4.61	3.16		4.1	4.29		2.97	3.83	4.41
2	lug-23	2.51		4.02	4.57		3.2	3.91	4.32		2.85	3.83	4.53
3	lug-23	2.78	3.26		4.49	3.01		4.1			2.81		4.53
1	lug-23	2.49	3.26		4.49	3.16		4.1	4.29		2.97	3.83	4.45
2	lug-23	2.51		4.02	4.57		3.2	3.91	4.32		2.77	3.83	4.57
3	lug-23			4.02	4.53	3.01		4.1			2.81		4.49
1	lug-23	2.49	3.26	3.91	4.41	3.01		4.1			2.81	3.83	4.49
2	lug-23			3.95	4.53	3.16		4.1	4.32		2.85		4.53
3	lug-23	2.51		3.79	4.45	3.05			4.3		2.97	3.83	4.45
1	ago-23		3.46	3.95	4.49	3.16	3.55	3.91			2.66	3.91	4.49
2	ago-23			3.95	4.42	3.01		4.1			2.7	3.94	4.53
3	ago-23			3.95	4.53	3.01	3.51	3.91			2.81		4.65
1	ago-23		3.46	3.95	4.49		3.55	3.91			2.66	3.91	4.49
2	ago-23			3.95	4.53	3.01		4.1			2.7	3.94	4.53
3	ago-23			3.95	4.49	3.01	3.51	3.91			2.81		4.65
1	ago-23		3.46	3.95	4.49		3.55	3.91			2.7	3.91	4.49
2	ago-23			4.06	4.77	3.01		4.1			2.7	3.94	4.53
3	ago-23			3.95	4.53	3.01	3.51	3.91			2.73		4.49
1	set-23	2.89	3.46	3.98	4.53	2.97	3.54	4.14			2.73		4.49
2	set-23		3.41	3.95	4.92	3.01		3.95			2.81		4.53
3	set-23		3.36	4.06	4.61	2.93	3.51	4.1			2.7		4.57
1	set-23	2.89	3.46	3.98	4.53	2.97	3.54	4.1			2.73		4.49
2	set-23		3.36	4.06	4.61	3.01		3.91			2.81		4.53
3	set-23		3.41	3.95	4.3	2.93	3.51	4.1			2.7		4.57
1	set-23	2.89	3.46	3.98	4.53	2.97	3.54	4.1			2.73		4.49

Monitoring activity on Fiorenza Node of A4 Highway

2	set-23	3.41	3.95	4.3	3.01	3.91	2.81	4.53		
3	set-23		3.98	4.53	2.93	3.51	4.14	2.7	4.57	
1	ott-23	3.08	3.91	4.61	3.09	3.95	4.68	2.73	4.65	
2	ott-23		3.91	4.57	3.01	4.02	4.61	3.09	4.65	
3	ott-23	3.12	4.06	4.69	3.01	3.75	4.61	2.77	3.73	4.61
1	ott-23	3.08	3.91	4.61	3.09	3.6	4.68	2.77	4.65	
2	ott-23		3.91	4.57	2.97	4.02	4.61	3.09	4.65	
3	ott-23	3.12	4.06	4.69	3.01	4.02	4.61	2.77	3.73	4.61
1	ott-23	3.08	3.91	4.61	3.09	3.63	4.68	3.09	4.65	
2	ott-23		3.91	4.53	2.97	4.02	4.61	2.77	4.65	
3	ott-23		3.91	4.65	2.97	3.91	2.73	4.61		
1	nov-23		4.06	4.61	3.48	4.06	2.7	3.95	4.61	
2	nov-23		4.02	4.69	3.01	3.75	2.66	3.63	4.57	
3	nov-23		4.02	4.69	3.32	3.75	2.7	4.65		
1	nov-23		4.06	4.61	3.48	4.06	2.66	3.95	4.61	
2	nov-23		4.02	4.65	3.01	4.14	2.7	3.63	4.57	
3	nov-23		4.02	4.65	3.13	3.87	2.7	4.65		
1	nov-23		4.06	4.61	3.48	4.06	2.7	3.95	4.61	
2	nov-23		4.1	4.88	3.01	4.14	2.66	3.63	4.66	
3	nov-23		4.14	4.77	3.32	4.02	2.7	4.65		
1	dic-23		4.1	4.65	3.13	3.98	4.69	2.73	3.36	4.93
2	dic-23		4.02	4.61	3.06	3.98	4.77	2.73	3.44	4.73
3	dic-23		4.18	4.77	3.13	4.1	4.73	2.73	3.71	4.65
1	dic-23		4.1	4.65	3.13	3.98	4.69	2.7	3.36	4.73
2	dic-23		4.02	4.61	3.09	3.98	4.77	2.73	3.49	4.65
3	dic-23		4.18	4.77	3.13	4.1	4.69	2.73	4.73	
1	dic-23		4.1	4.65	3.13	3.98	4.69	2.73	3.49	4.65
2	dic-23		4.14	4.69	3.13	4.1	2.7	4.73		
3	dic-23		4.06	4.65	3.09	4.1	2.73	3.36	4.69	

4.2.1 Vertical direction (x)

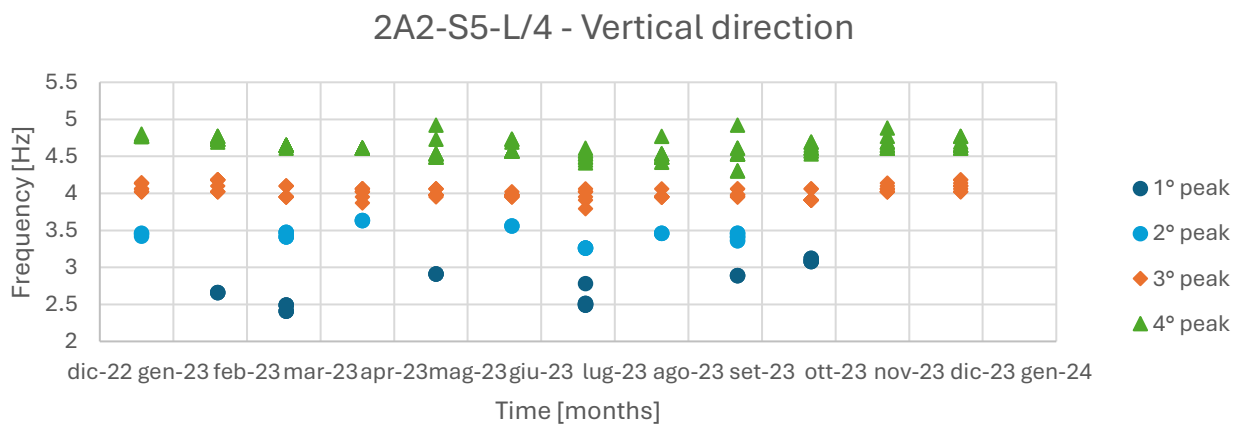

Figure 4-6: 2A2-S5-L/4 - Natural frequencies obtained in vertical direction

4.2.2 Longitudinal direction (y)

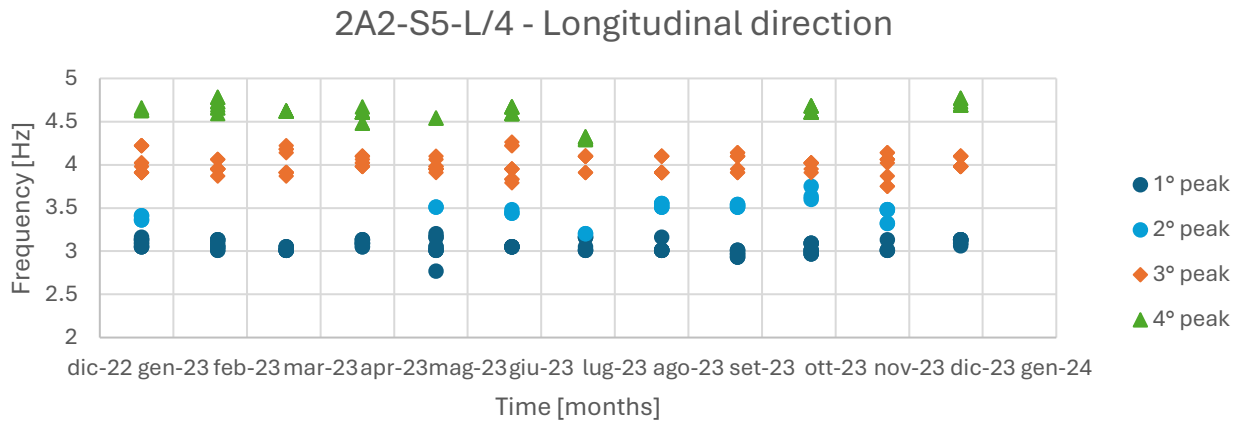

Figure 4-7: 2A2-S5-L/4 - Natural frequencies obtained in longitudinal direction

4.2.3 Transverse direction (z)

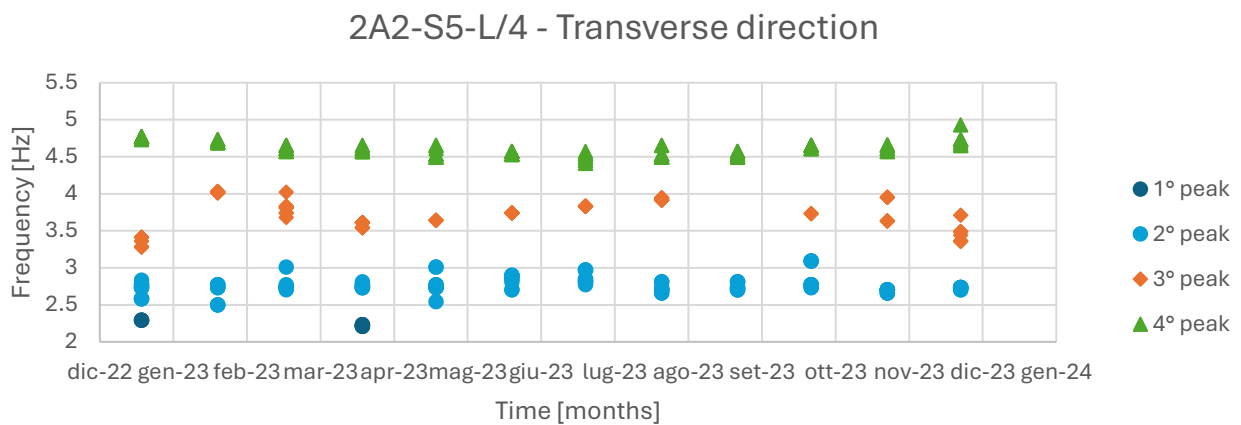

Figure 4-8: 2A2-S5-L/4 - Natural frequencies obtained in transverse direction

4.3 2A2 SP5 L/8 Sensor 2B988

The natural frequencies have been now classified and represented in such a way to obtain the variation of the values during the year. So, each peak value has been identified and the following representation for the vertical, longitudinal and transverse direction have been obtained.

Table 4-4 2023 natural frequencies [Hz] identified for sensor 2B988 – 2A2 SP5 L/8

	Vertical direction				Longitudinal direction				Transverse direction			
	1° peak	2° peak	3° peak	4° peak	1° peak	2° peak	3° peak	4° peak	1° peak	2° peak	3° peak	4° peak
Numerosity	20	27	99	97	92	41	91	56	20	107	68	101
MEAN	2.77	3.41	4.01	4.61	3.03	3.48	4.03	4.60	2.09	2.75	3.76	4.57
SD	0.14	0.15	0.08	0.08	0.11	0.16	0.09	0.13	0.11	0.10	0.20	0.11
C.o.V.	5.2%	4.3%	1.9%	1.8%	3.6%	4.6%	2.3%	2.8%	5.5%	3.6%	5.2%	2.5%
Rating	16%	23%	100%	99%	81%	34%	89%	52%	16%	95%	54%	97%

Monitoring activity on Fiorenza Node of A4 Highway

1	gen-23		4.02	4.8	3.13		4.06	4.61	2.21	2.58	3.91	4.34
2	gen-23		4.14		3.09	3.37	4.22		2.21	2.73		4.69
3	gen-23		4.06	4.69	3.16		4.02	4.78	2.09	2.85	3.69	4.45
1	gen-23		4.02	4.8	3.16		4.06	4.61		2.58	3.91	4.38
2	gen-23		4.14		3.13	3.37	4.22			2.73		4.68
3	gen-23		4.06	4.69	3.09		4.02	4.48		2.81	3.89	4.68
1	gen-23		4.02	4.81	3.13	3.37	4.21			2.58	3.91	4.33
2	gen-23		4.14		3.13		4.06	4.61		2.81	3.89	4.68
3	gen-23		4.14		3.09		3.91	4.63		2.73		4.72
1	feb-23	2.66	4.02	4.77	3.13		3.98	4.73		2.5	4.02	4.69
2	feb-23		4.18	4.73	3.01		4.06	4.73		2.73	3.48	4.69
3	feb-23		4.06	4.73	3.05		3.95	4.59		2.77	4.08	4.69
1	feb-23	2.62	4.02	4.77	3.13		3.98	4.73		2.5	4.02	4.69
2	feb-23		4.18	4.73	3.01		4.05	4.73		2.73	3.48	
3	feb-23		4.18	4.76	3.06		3.95	4.59		2.77	4.08	4.69
1	feb-23	2.62	4.18	4.73	3.13		3.98	4.73		2.73	3.48	4.69
2	feb-23		4.1	4.77	3.05		4.06	4.73		2.5	4.02	4.69
3	feb-23		4.02	4.69	3.01		3.95	4.59		2.77	4.08	4.69
1	mar-23	2.62	3.95	4.65	3.01		4.18		1.96	2.73	3.79	4.53
2	mar-23		3.47	4.1	4.65	3.01	3.57	3.91		2.77	3.83	4.65
3	mar-23		3.98	4.61	3.13		3.98		2.18	2.73	3.6	4.45
1	mar-23	2.62	3.95	4.65	3.01		4.14		1.96	2.73	3.79	4.53
2	mar-23		3.47	3.98	4.65	3.01	3.57	3.91		2.18	2.77	3.83
3	mar-23		4.1	4.61	3.05		3.91	4.71		2.18	2.73	3.6
1	mar-23		3.98	4.61	3.01	3.57	4.18			2.18	2.77	
2	mar-23	2.62	3.95	4.65	3.01		3.91			2.18	2.77	4.41
3	mar-23		4.1	4.61	3.05		3.91	4.71		2.31	2.77	4.3
1	apr-23		4.06	4.61	3.09		4.1	4.73		2.77		4.45
2	apr-23		4.06	4.61	3.05		4.14			2.77	4.09	4.68
3	apr-23	2.98	4.17	4.61	3.09		3.98	4.65	2.21	2.77	4.09	4.61
1	apr-23		4.07	4.61	3.09		4.1	4.73		2.77		4.45
2	apr-23		3.87	4.61	3.13		4.14		2.04	2.77	4.09	4.61
3	apr-23		4.02	4.61	3.05		3.95	4.65		2.73	4.09	4.69
1	apr-23		4.06	4.61	3.09		4.1	4.73		2.77	4.09	4.61
2	apr-23		3.87	4.69	3.13		3.98	4.65		2.77		4.45
3	apr-23		4.1	4.57	3.13		4.02	4.73	2.04	2.73	4.09	4.68
1	mag-23	2.89	3.95	4.53	3.01		3.98			2.77	3.76	4.53
2	mag-23	2.92	4.06	4.53	3.2	3.54	3.98	4.51		2.73		4.49
3	mag-23		4.02		2.82	3.49	4.06	4.54		2.54		4.61
1	mag-23	2.89	3.95	4.53	3.01		3.98			2.77	3.76	4.53
2	mag-23	2.92	4.06	4.53	3.16	3.54	4.1	4.51		2.73		4.49
3	mag-23		3.98	4.61	2.83	3.49	3.98	4.54		2.54		4.61
1	mag-23	2.89	3.95	4.53	3.01		4.02			2.77	3.76	4.53
2	mag-23	2.92	4.06	4.53	3.16	3.54	3.98	4.51		2.77		4.49
3	mag-23		3.98		2.82	3.49	4.06	4.54		2.73	3.79	
1	giu-23		3.95	4.61	3.05		3.91		1.93	2.77	3.71	4.56

Monitoring activity on Fiorenza Node of A4 Highway

2	giu-23			3.98	4.57		3.39		4.26		2.89	3.75	4.57
3	giu-23		3.56		4.57		3.91		4.53		2.7		4.53
1	giu-23			3.95	4.61	3.05		3.91		1.93	2.77	3.71	4.53
2	giu-23			3.95	4.57		3.39		4.26		2.89	3.75	4.57
3	giu-23		3.56		4.57			3.87	4.53		2.7		4.53
1	giu-23			3.95	4.61	3.05		3.91		1.93	2.77	3.71	4.57
2	giu-23		3.56		4.57		3.45		4.26		2.81		4.53
3	giu-23			3.95	4.57	3.09			4.57		2.89		4.53
1	lug-23			3.23	3.91	4.45	2.73	3.18	4.14		2.81	3.78	4.3
2	lug-23	2.61	3.21	3.95	4.49	2.68	3.19	3.91	4.39		2.97	3.6	4.49
3	lug-23				4.49	3.01			4.45		2.73	3.82	
1	lug-23		3.23	3.95		2.73	3.18	4.14			2.81		4.3
2	lug-23	2.61	3.21		4.49	2.68	3.19	3.91	4.39		2.97		4.49
3	lug-23			3.95	4.53	3.01		4.1	4.45		2.73	3.55	4.49
1	lug-23			3.95	4.49	3.01		4.1			2.81		4.29
2	lug-23		3.23	3.91		2.73	3.19	3.91	4.39		2.97	3.83	4.49
3	lug-23	2.61	3.21		4.49	2.68	3.18	4.14	4.45		2.73		4.45
1	ago-23		3.31	3.91	4.49		3.55	3.91			2.7		4.45
2	ago-23			4.1	4.68	3.01	3.49	4.1	4.76		2.7	3.69	4.49
3	ago-23			3.95	4.49	3.01		3.95			2.85	3.69	4.65
1	ago-23		3.31	3.91	4.49		3.55	3.91			2.7		4.45
2	ago-23			4.1	4.69	3.01	3.49	4.1	4.76		2.7	3.69	4.49
3	ago-23			3.95	4.49	3.01		3.95			2.85	3.69	4.65
1	ago-23		3.31	3.91	4.49		3.55	3.91			2.7		
2	ago-23			3.98	4.68	3.01	3.49	4.1	4.76		2.69	3.69	4.49
3	ago-23			4.1		3.01		3.95			2.69	3.61	4.45
1	set-23		3.34	3.98	4.53	2.97	3.55				2.73		4.49
2	set-23	2.81	3.52	3.95	4.57	3.01		3.91			2.7		4.57
3	set-23		3.54	3.98	4.53	2.97	3.44	4.14	4.68		2.73	3.95	
1	set-23		3.34	3.98	4.53	2.97	3.55				2.73		4.49
2	set-23	2.81	3.52	3.95	4.53	3.01		3.94			2.7		4.57
3	set-23	2.99		3.98	4.57	2.97	3.44	4.14	4.68		2.73	3.95	
1	set-23		3.34	3.98	4.53	2.97	3.55				2.73		4.49
2	set-23	2.81	3.52	3.95	4.57	3.01		3.95			2.7		4.53
3	set-23		3.54	4.06	4.61	2.97	3.43	4.1	4.68				4.57
1	ott-23			3.95	4.61	3.09					2.73	3.67	4.65
2	ott-23			3.91	4.61			4.02	4.67	2.01	2.77	3.75	4.57
3	ott-23		3.28	4.06	4.68	2.97	3.71				3.05		4.65
1	ott-23			3.95	4.61	3.09					2.73	3.67	4.65
2	ott-23		3.28	4.02	4.68			4.02	4.67	2.01	2.77	3.75	4.57
3	ott-23			4.06	4.57	2.97	3.71				3.09		4.65
1	ott-23			3.95	4.61	3.09					2.77	3.67	4.65
2	ott-23			4.02	4.61			4.02	4.67		3.09		4.65
3	ott-23			3.91	4.61	2.97	3.71			2.09	2.77		4.57
1	nov-23			3.98	4.61		3.47	4.06			2.73	3.63	4.65
2	nov-23				4.65	3.01					2.66	3.63	4.76
3	nov-23			3.88	4.57		3.68	4.02			2.73	3.67	4.57

Monitoring activity on Fiorenza Node of A4 Highway

1	nov-23		3.98	4.61	3.48	4.06	2.73	3.59	4.65	
2	nov-23			4.65	3.01	4.14	2.66	3.53	4.57	
3	nov-23		4.06		3.09	4.14	2.77		4.65	
1	nov-23		3.98	4.61	3.48	4.06	2.73	3.63	4.65	
2	nov-23		4.1	4.65	3.01	4.17	2.73	3.63	4.57	
3	nov-23					4.02	2.66		4.6	
1	dic-23		4.1	4.61	3.09	4.02	4.59	2.73	3.4	4.77
2	dic-23		3.95	4.69	3.05	3.89	4.63	2.73	3.55	4.77
3	dic-23	3.62	4.06	4.69	3.13	4.1		2.7	3.4	4.65
1	dic-23		4.1	4.61	3.09	4.02	4.59	2.73	3.39	4.77
2	dic-23		3.95	4.73	3.04	3.87	4.63	2.7	3.55	4.77
3	dic-23	3.62	4.06	4.69	3.09	4.1		2.73		4.69
1	dic-23		4.1	4.73	3.08	4.02	4.59	2.7	3.4	4.61
2	dic-23		3.95	4.61	3.13	4.1		2.73	3.98	4.73
3	dic-23	3.62	4.06	4.65	3.09			2.77		4.63

4.3.1 Vertical direction (x)

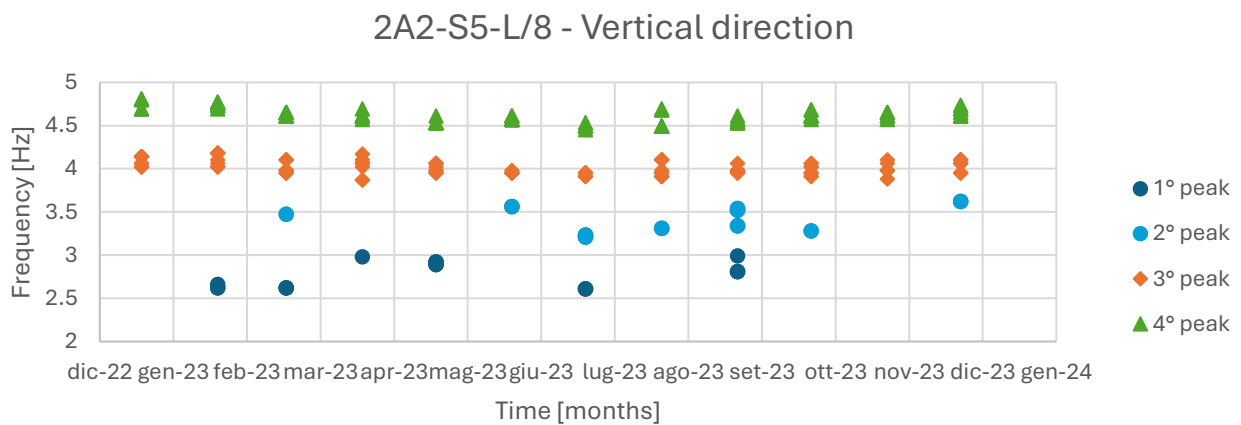

Figure 4-9: 2A2-S5-L/8 - Natural frequencies obtained in vertical direction

4.3.2 Longitudinal direction (y)

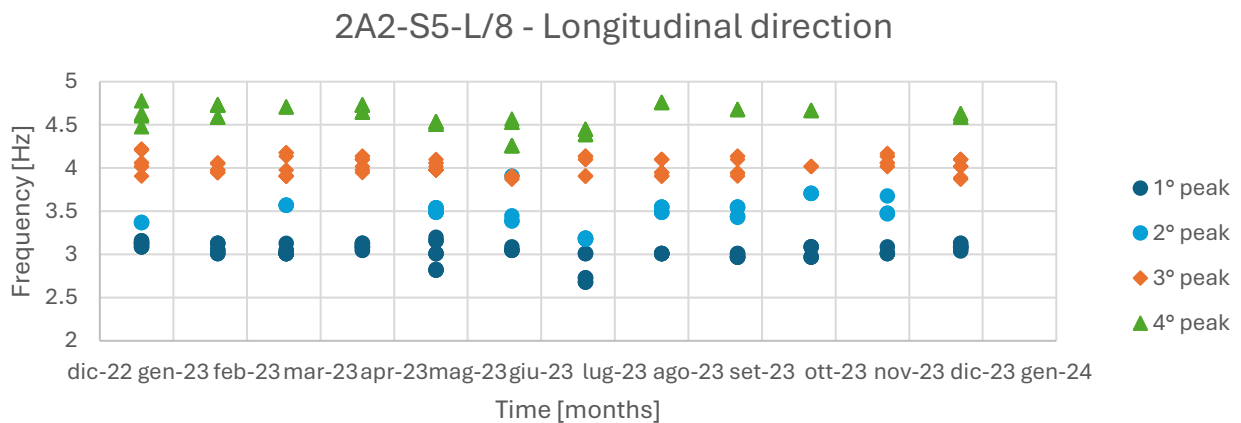

Figure 4-10: 2A2-S5-L/8 - Natural frequencies obtained in longitudinal direction

4.3.3 Transverse direction (z)

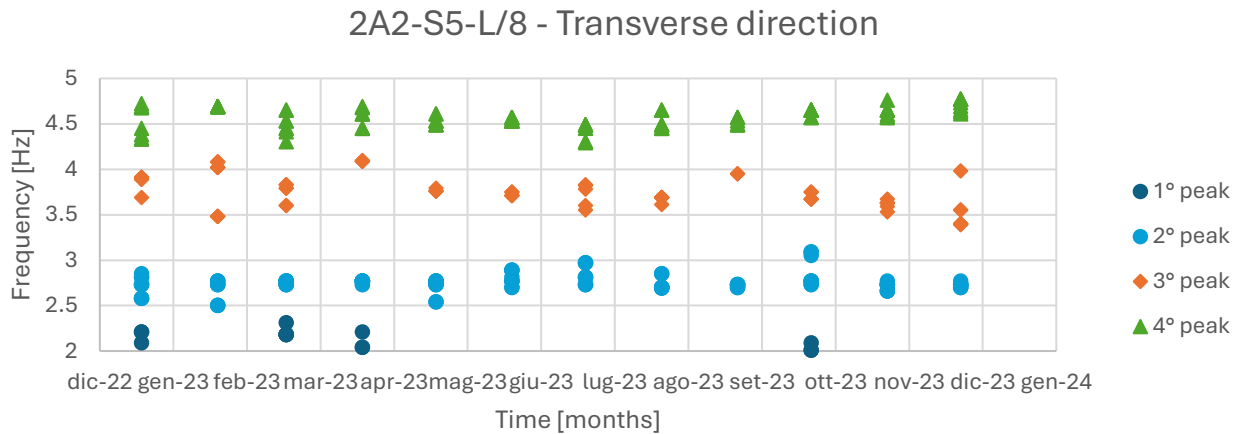

Figure 4-11: 2A2-S5-L/8 - Natural frequencies obtained in transverse direction

4.4 2A2 SP5 Pier Sensor 2C1E4

All the obtained frequencies have been now classified and represented in such a way to obtain the variation of the values during the year. So, the peaks value has been separated and the representation for the vertical, longitudinal and transverse direction have been obtained.

Table 4-5 2023 natural frequencies [Hz] identified for sensor 2C1E4 – 2A2 SP5 Pier

	Vertical direction				Longitudinal direction				Transverse direction			
	1° peak	2° peak	3° peak	4° peak	1° peak	2° peak	3° peak	4° peak	1° peak	2° peak	3° peak	4° peak
Numerosity	95	36	78	56	88	31	90	66	29	107	79	67
MEAN	2.76	3.66	4.09	4.66	3.04	3.57	4.02	4.63	2.17	2.77	3.72	4.54
SD	0.07	0.10	0.10	0.16	0.06	0.07	0.08	0.09	0.11	0.09	0.11	0.17
C.o.V.	2.5%	2.8%	2.5%	3.3%	2.0%	2.1%	2.0%	2.0%	5.0%	3.3%	2.9%	3.7%
Rating	94%	35%	77%	52%	91%	32%	93%	68%	24%	100%	76%	61%
1 Jan-23	2.81		4.14		3.09		4.06		1.91	2.58		4.36
2 Jan-23	2.65		4.1	4.77	2.91		3.86		1.95	2.71	3.71	4.69
3 Jan-23	2.81		4.16	4.69	3.13		4.07			2.66	3.62	
1 Jan-23	2.81		4.14		3.13		4.06		1.95	2.58	3.89	
2 Jan-23	2.81		4.22	4.69	2.96		3.89			2.77	3.75	4.69
3 Jan-23	2.73		4.25		3.13		3.94	4.69		2.73	3.82	4.61
1 Jan-23	2.81		4.1	4.61	3.08		4.06			2.58	3.89	
2 Jan-23	2.81	3.41	3.95		3.13		3.91	4.69		2.73	3.75	4.69
3 Jan-23	2.59		3.96	4.39	3.09		4.14			2.77	3.82	
1 Feb-23	2.73				3.13		3.98	4.73		2.73	3.52	
2 Feb-23	2.77		4.02	4.65	3.01		4.06	4.61		2.61		4.66
3 Feb-23	2.59		4.18	4.88	3.04		3.98	4.72		2.74		4.29
1 Feb-23	2.73		4.02		3.13		3.98	4.73		2.73	3.52	
2 Feb-23	2.58		4.18	4.65	3.05		4.06	4.73		2.59		4.66

Monitoring activity on Fiorenza Node of A4 Highway

3	Feb-23	2.77		4.02	4.92	3.05		3.99	4.65	2.77			
1	Feb-23	2.73		4.02		3.13		3.98	4.73	2.73	3.52		
2	Feb-23	2.73		4.16	4.91	3.05		4.06	4.73	2.77		4.29	
3	Feb-23	2.61		4.03	4.65	3.05		3.95	4.65	2.59		4.66	
1	Mar-23	2.81	3.36	3.83	4.6	3.01		4.1		2.81	3.82	4.57	
2	Mar-23	2.73				3.01		3.94	4.65	2.73		4.43	
3	Mar-23	2.73		3.79	4.92			4.12		2.77	3.86		
1	Mar-23	2.81	3.39	3.87	4.61	3.01		3.91	4.65	2.81	3.83	4.61	
2	Mar-23	2.73		3.84		3.01		3.91	4.65	2.73		4.38	
3	Mar-23	2.73		3.82	4.92	3.05		4.1		2.77	3.83	4.66	
1	Mar-23	2.81		3.87	4.61	3.01		4.1		2.22	2.7	3.63	4.41
2	Mar-23	2.7			4.59	3.01		3.91	4.65	2.22	2.77		
3	Mar-23	2.77				3.05		3.91	4.65	2.81	3.83	4.57	
1	Apr-23	2.73	3.75	4.22		3.01		4.19		2.14	2.77	3.67	4.22
2	Apr-23	2.77		4.14		2.97	3.43		4.61	2.77	3.67	4.41	
3	Apr-23	2.77			4.56	3.04		4.06	4.61	2.11	2.77	3.63	
1	Apr-23	2.77	3.75	4.22		2.97	3.43	3.98	4.61	2.77	3.67	4.22	
2	Apr-23	2.77		4.14		3.06		4.06	4.61	2.15	2.77	3.63	4.18
3	Apr-23	2.81	3.79	4.14		3.01		4.16		2.77		4.41	
1	Apr-23	2.77		4.14		3.05		4.14		2.19	2.77	3.63	
2	Apr-23	2.73	3.75	4.22		3.09		4.1	4.65	2.27	2.77	3.6	4.53
3	Apr-23	2.77	3.75	4.33				4.06	4.57	2.77		4.38	
1	May-23	2.81		3.95	4.84	3.01	3.62	4.09		2.81	3.71	4.84	
2	May-23	2.73		4.13	4.88	3.14	3.62	3.98	4.53	2.73	3.67	4.59	
3	May-23	2.77					3.62		4.51	2.73			
1	May-23	2.81		4.16	4.84	3.14	3.63	3.98	4.53	2.81	3.71	4.84	
2	May-23	2.73		4.07	4.91	2.89	3.67		4.53	2.73	3.67		
3	May-23	2.77	3.75	4.07		3.01	3.67	4.09		2.26	2.77	4.81	
1	May-23	2.77		4.07	4.92	3.01	3.67	4.09		2.81	3.75	4.76	
2	May-23	2.81		4.16	4.88	3.14	3.67	3.98	4.53	2.14	2.77	3.79	
3	May-23	2.77	3.75			2.89	3.67		4.53	2.81	3.75		
1	Jun-23		3.64		4.69	3.05		3.89	4.73	2.29	2.89	3.71	
2	Jun-23		3.61		4.53			3.93		2.91	3.79	4.49	
3	Jun-23		3.61		4.41				4.52	2.92			
1	Jun-23	2.89	3.75		4.65	3.05		3.92	4.71	2.34	3.01	3.71	4.39
2	Jun-23	2.76	3.71		4.53					2.89	3.79	4.52	
3	Jun-23		3.71					3.98	4.57	3.01			
1	Jun-23	2.89	3.75		4.65	3.05		3.89	4.71	3.01		4.29	
2	Jun-23	2.76	3.71		4.53			3.95		2.34	3.01	3.71	4.41
3	Jun-23	2.69	3.71					3.91	4.57			3.68	
1	Jul-23	2.65		4.1		3.01		4.15	4.69	2.21	2.81	3.79	4.38
2	Jul-23			4.14	4.53	3.01			4.88	2.16	2.89	3.79	
3	Jul-23	2.73			4.68			4.01		2.77			
1	Jul-23	2.89	3.69	4.14		3.01			4.59	2.81	3.79	4.39	

Monitoring activity on Fiorenza Node of A4 Highway

2	Jul-23	2.91	3.61	4.1		3.09	4.02		2.93	3.79			
3	Jul-23	2.71	3.59		4.46	2.83	4.06		2.26	2.82	3.71		
1	Jul-23	2.81	3.69		4.34	3.09	4.01			2.81	3.82	4.39	
2	Jul-23	2.89		4.14	4.57	3.09	4.04	4.51		2.93	3.82		
3	Jul-23	2.92		4.1		3.01			2.26	2.82	3.69		
1	Aug-23		3.61		4.39	3.01	3.55	3.96	4.49	2.69	3.56		
2	Aug-23	2.69		4.1		3.12	3.91			2.69	3.71	4.41	
3	Aug-23				4.46			4.57		2.76	3.62	4.53	
1	Aug-23		3.71	4.19		3.12	3.55	3.91	4.49	2.7	3.56		
2	Aug-23	2.69		4.1	4.7	3.01	3.91			2.7	3.71	4.41	
3	Aug-23	2.76						4.57		2.79	3.63	4.57	
1	Aug-23			4.29		3.12	3.55	3.91	4.49	2.69	3.71	4.41	
2	Aug-23	2.69		4.26	4.8	2.97	3.63	4.04	4.67	2.69	3.56	4.38	
3	Aug-23	2.73				3.01				2.3	2.77		
1	Sep-23	2.73		4.14	4.61	2.97	3.55			2.07	2.73	4.04	
2	Sep-23	2.77		3.91		3.01				2.73	3.95		
3	Sep-23	2.77				2.97	3.48	3.95	4.53	2.77			
1	Sep-23	2.73		4.1	4.61	2.97	3.54			2.07	2.73	3.96	
2	Sep-23	2.77	3.79			3.01	3.94			2.77	3.79		
3	Sep-23	2.77	3.72	4.14		2.97	3.46		4.53	2.73			
1	Sep-23	2.73		4.1	4.61	2.97	3.55			2.07	2.73	3.96	
2	Sep-23	2.77				3.01	3.91			2.73			
3	Sep-23	2.91	3.72				3.94	4.53		2.77	3.79		
1	Oct-23	2.77		4.07	4.49	3.09	4.06	4.69		2.77	3.68	4.69	
2	Oct-23	2.77		4.07			4.02	4.61		3.01			
3	Oct-23			4.14		3.01		4.61		2.77	3.75	4.65	
1	Oct-23	2.77	3.71	4.07	4.53	3.09	4.09			2.73	3.67	4.69	
2	Oct-23	2.96		4.02			4.02	4.65		3.01		4.45	
3	Oct-23	2.77		4.14		3.01	4.06	4.61		2.77	3.75		
1	Oct-23	2.96		4.06		3.09	4.02			3.01		4.49	
2	Oct-23	2.77	3.71	4.06	4.53		4.1	4.61		2.77	3.75	4.69	
3	Oct-23	2.81		4.14		3.09	4.02	4.53		2.77		4.53	
1	Nov-23	2.73	3.59		4.53		3.48	4.06	4.53	2.69	3.61	4.41	
2	Nov-23	2.69		4.1		3.01	3.61	4.13	4.8	2.72	3.64	4.57	
3	Nov-23	2.73		4.1			4.11		2.09	2.79		4.65	
1	Nov-23	2.73	3.63				3.48	4.06	4.57	2.73	3.63	4.41	
2	Nov-23	2.7	3.63	4.09	4.53	3.05	4.11	4.77		2.7	3.63	4.57	
3	Nov-23	2.77		4.09		3.01	3.61	4.13		2.22	2.81	4.61	
1	Nov-23	2.73	3.59		4.53		3.48	4.06	4.53	2.73	3.63	4.41	
2	Nov-23	2.7	3.63	4.09		3.01	3.61	4.1		2.7	3.63	4.57	
3	Nov-23	2.73		4.09		3.13	4.1			2.7	3.59		
1	Dec-23			4.06	4.84	3.09	3.55	4.02	4.77	2.73	3.84	4.8	
2	Dec-23	2.73		4.1	4.65	3.09	4.14			2.18	2.73	3.63	4.76
3	Dec-23	2.77		4.1		3.09	4.14	4.77		2.22	2.73	3.71	4.68

1	Dec-23		4.06	4.84	3.08	3.55	4.02	4.72		2.73	3.89	4.8	
2	Dec-23	2.77	4.1	4.62	3.08		4.14	4.76		2.73	3.64	4.77	
3	Dec-23	2.77	3.63	4.09		3.08	3.69	4.14	4.76	2.14	2.77	3.75	4.69
1	Dec-23		4.06	4.84	3.08	3.55	4.02	4.73		2.73	3.89	4.8	
2	Dec-23	2.77	4.14	4.65	3.13	3.55	4.1	4.77		2.14	2.77	4.69	
3	Dec-23	2.73	4.14	4.65	3.05		4.1			2.7	3.64	4.73	

4.4.1 Vertical direction (x)

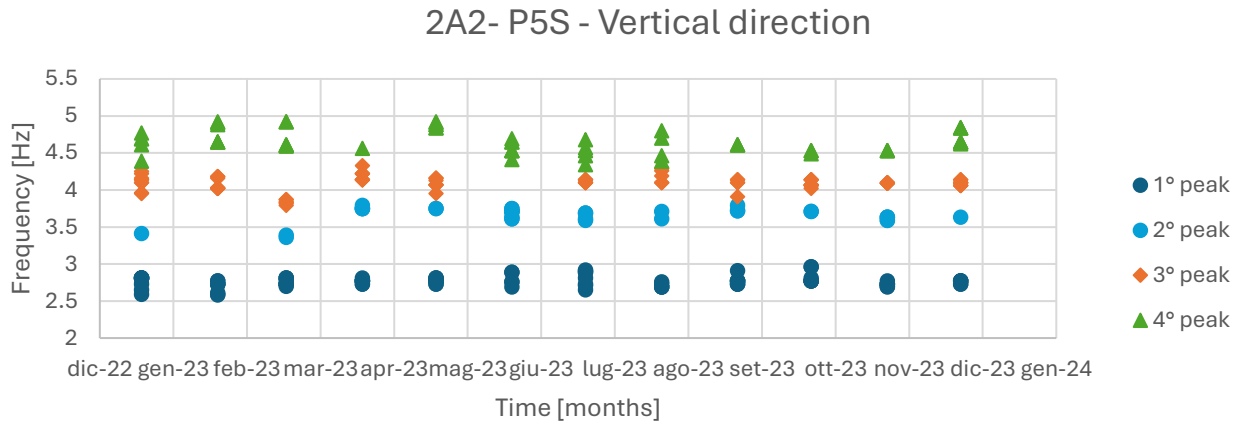

Figure 4-12: 2A2- P5S - Natural frequencies obtained in vertical direction

4.4.2 Longitudinal direction (y)

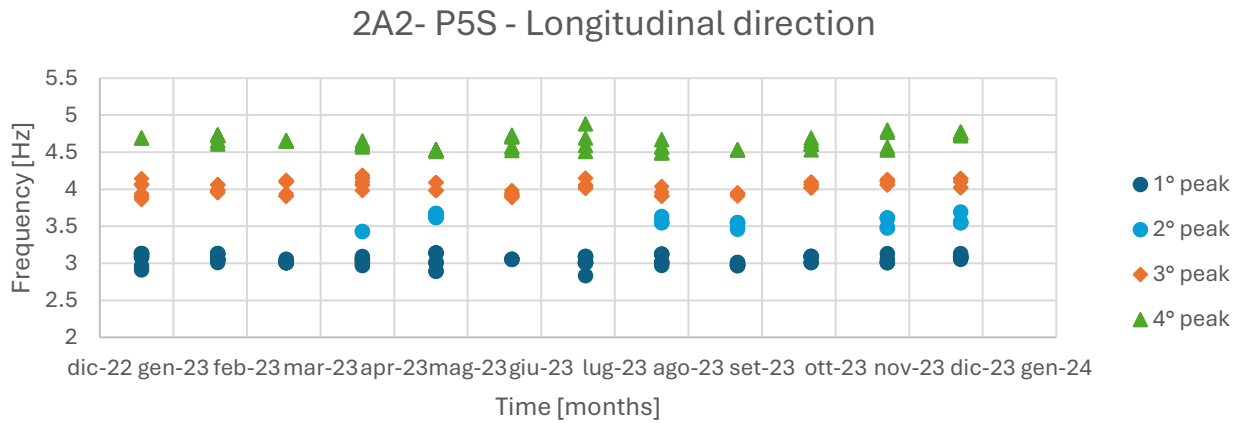

Figure 4-13: 2A2- P5S - Natural frequencies obtained in longitudinal direction

4.4.3 Transverse direction (z)

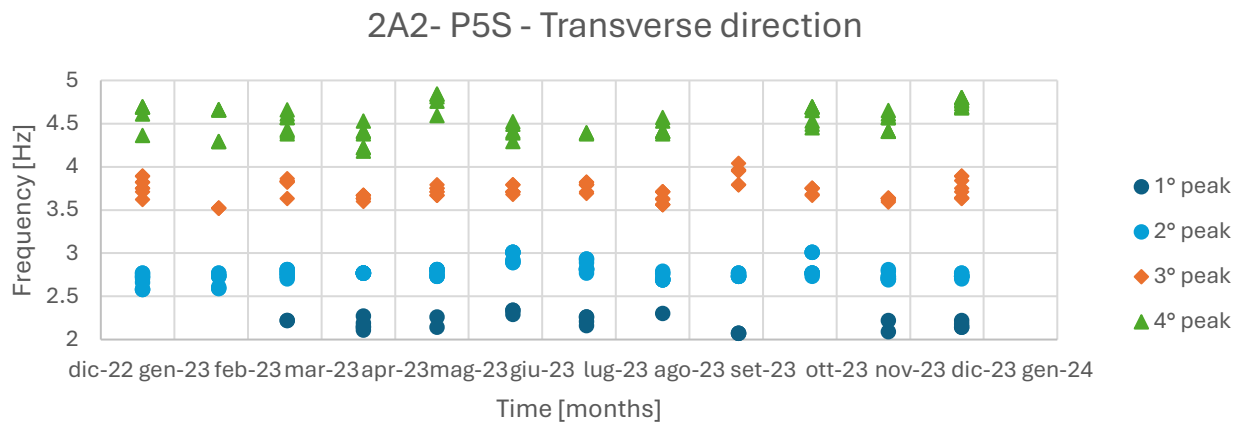

Figure 4-14: 2A2- P5S - Natural frequencies obtained in transverse direction

5. Bridge 223 deck 2

The Bridge 223 counts 2 monitored decks: span 2 and span 6 (see Figure 5-1).

On the deck number 2, 5 sensors are present: one in the midspan ($L/2$), one at $L/4$ of the span, one at $L/8$ of the span and in this case one on the east pier and one on the west pier.

The sensors present on deck number 2 are:

- 2BE0F – situated in the midspan;
- 2BA63 – situated at a distance of $L/4$;
- 31205 – situated at a distance of $L/8$;
- 319BC – situated nearby the west pier;
- 319E3 – situated nearby the east pier.

Monitored deck

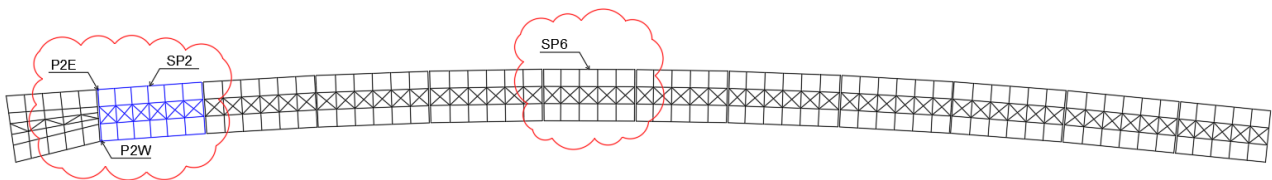
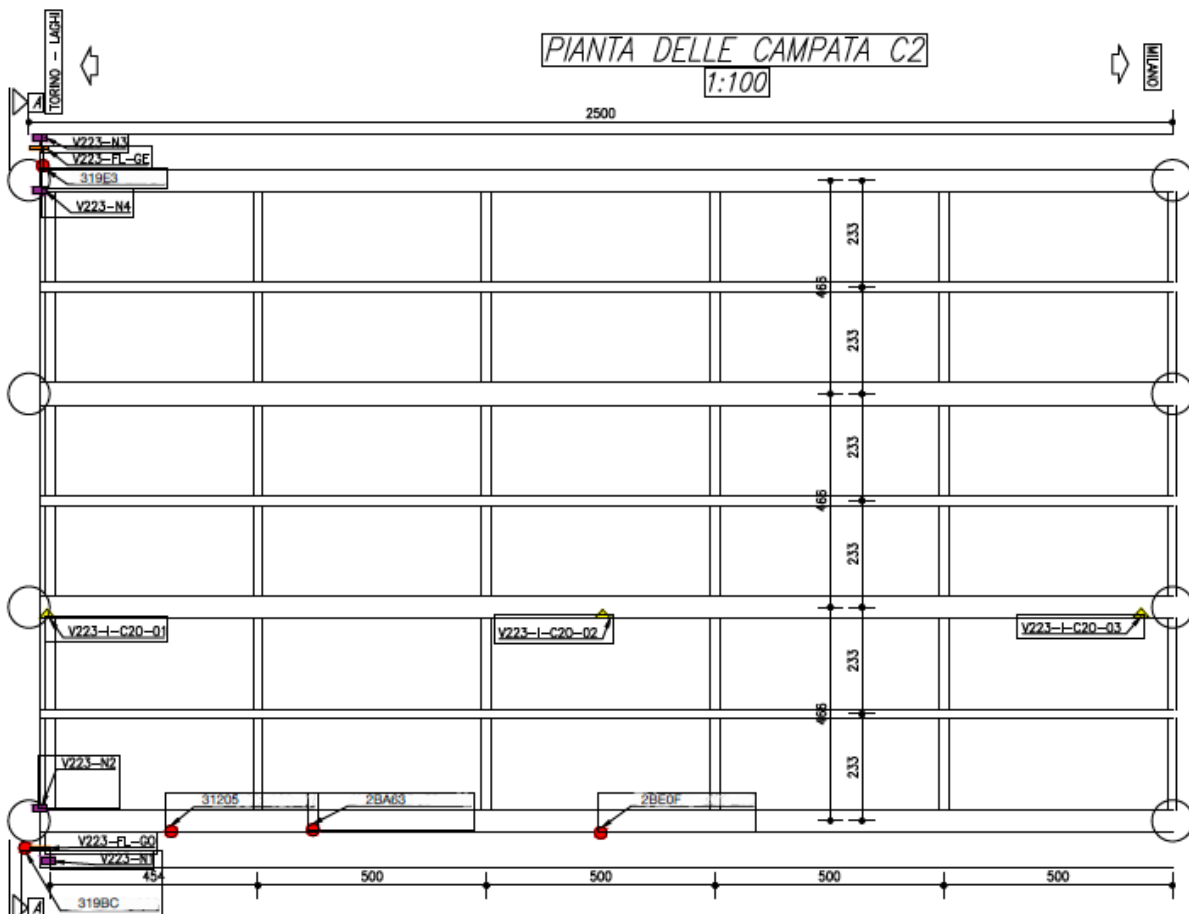

Figure 5-1: Deck 2 of 223 bridge



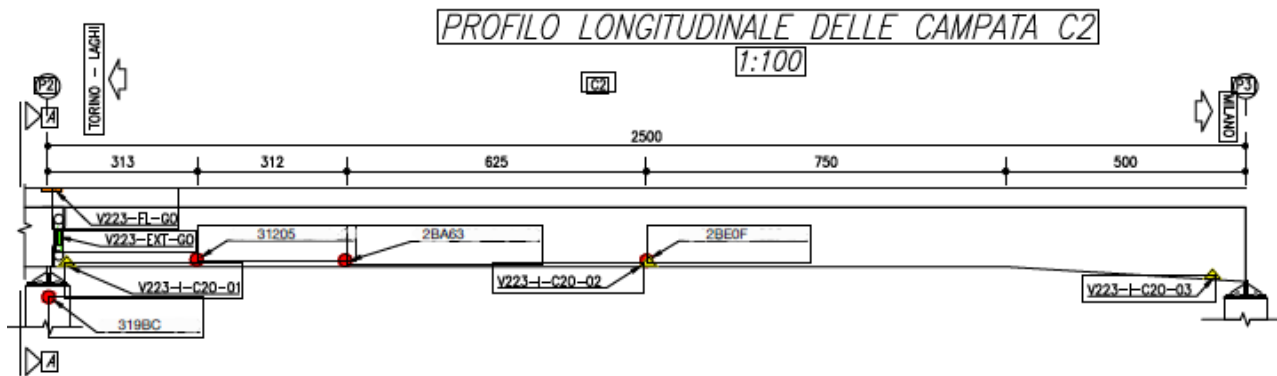

Figure 5-2: Sensor position on deck 2 of 223 bridge

All the accelerograms registered at scheduled times (every 6 hours) and long 102s have been analyzed and the results are represented in the following Annexes:

- Annex 9 – Sensor 2BE0F
- Annex 10 – Sensor 2BA63
- Annex 11 – Sensor 31205
- Annex 12 – Sensor 319BC
- Annex 13 – Sensor 319E3

The mean frequencies values identified for this deck are presented in Table 5-1.

Table 5-1 2023 Average natural frequencies [Hz] identified for 223 deck 2

Direction	Frequency	L/2	L/4	L/8	West pier	East pier
Vertical	1 st	2.46	2.46	2.46	2.33	2.23
	2 nd	2.89	2.89	2.88	2.84	2.80
	3 rd	4.06	4.05	4.05	3.98	3.90
	4 th	4.73	4.73	4.73	4.71	4.64
Longitudinal	1 st	2.35	2.44	2.45	2.45	2.46
	2 nd	2.83	2.88	2.87	2.87	2.89
	3 rd	3.82	4.05	4.04	4.05	4.03
	4 th	4.45	4.71	4.69	4.72	4.72
Transverse	1 st	2.11	2.17	2.16	2.25	2.16
	2 nd	2.84	2.82	2.80	2.81	2.82
	3 rd	3.66	3.78	3.73	3.74	3.68
	4 th	4.72	4.69	4.61	4.47	4.40

5.1 223 SP2 L/2 Sensor 2BE0F

All the obtained frequencies have been now classified and represented in such a way to obtain the variation of the values during the year. So, the peaks value has been separated and the representation for the vertical, longitudinal and transverse direction have been obtained.

Monitoring activity on Fiorenza Node of A4 Highway

Table 5-2 2023 natural frequencies [Hz] identified for sensor 2BE0F – 223 SP2 L/2

	Vertical direction				Longitudinal direction				Transverse direction				
	1° peak	2° peak	3° peak	4° peak	1° peak	2° peak	3° peak	4° peak	1° peak	2° peak	3° peak	4° peak	
Numerosity	94	101	104	106	90	104	102	60	73	106	45	98	
MEAN	2.46	2.89	4.06	4.73	2.35	2.83	3.82	4.45	2.11	2.84	3.66	4.72	
SD	0.04	0.04	0.07	0.07	0.06	0.07	0.17	0.19	0.13	0.05	0.14	0.08	
C.o.V.	1.5%	1.3%	1.7%	1.5%	2.7%	2.6%	4.4%	4.2%	6.3%	1.8%	3.7%	1.6%	
Rating	89%	97%	96%	100%	77%	89%	77%	46%	49%	97%	36%	91%	
1	gen-23	2.5	2.97	4.14	4.8	2.11	2.89	4.1		2.93		4.81	
2	gen-23	2.5	2.97	4.14	4.84	2.38	2.97	4.02	4.38	2.89		4.81	
3	gen-23	2.5	2.93	4.14	4.77		3.01	4.02		2.89		4.77	
1	gen-23	2.46	2.97	4.1	4.84	2.11	2.89	4.1		2.93		4.8	
2	gen-23	2.46	2.97	4.14	4.84	2.34	2.97	4.02	4.38	2.89		4.84	
3	gen-23	2.5	2.97	4.14	4.77	2.07	3.01	4.02		2.89		4.77	
1	gen-23	2.46	2.97	4.1	4.8	2.1	2.89	4.1		2.93		4.8	
2	gen-23	2.5	2.97	4.14	4.84	2.34	2.97	4.02	4.38	2.89		4.84	
3	gen-23	2.46	2.97	4.1	4.77	2.34	2.97	4.02	4.38	2.85		4.77	
1	feb-23	2.46	2.89	3.79	4.77	2.42	2.81	3.87	4.77	1.79	2.81	3.79	4.81
2	feb-23	2.5	2.89	4.06	4.8	2.34	2.81	3.79	4.73	1.86	2.81	3.64	4.73
3	feb-23	2.5	2.89	4.06	4.73	2.38	2.81	3.91		2.01	2.89		4.77
1	feb-23	2.46	2.89	3.79	4.77	2.42	2.85	3.87	4.77	1.6	2.81	4.02	4.8
2	feb-23	2.46	2.89	4.1	4.8	2.34	2.81	3.79	4.73	1.84	2.81		4.73
3	feb-23	2.46	2.89	4.1	4.73	2.34	2.81	3.91		2.07	2.89	3.92	4.77
1	feb-23		2.89	4.06	4.73	2.34	2.81	3.79	4.73		2.89		4.8
2	feb-23	2.46	2.89	4.1	4.81	2.38	2.81	3.91		1.83	2.81		4.73
3	feb-23		2.97	4.1	4.77	2.38	2.81	3.87	4.77	1.8	2.81		4.73
1	mar-23	2.42	2.85	3.98	4.69	2.3	2.73	3.78	4.36	2.15	2.89	3.79	4.69
2	mar-23	2.46	2.85	4.06	4.69	2.34	2.81	3.75	4.29	2.07	2.77		4.69
3	mar-23	2.42	2.89	4.06	4.73		3.01			2.15	2.92		4.72
1	mar-23	2.42	2.85	4.02	4.69	2.3	2.73	3.6	4.29	2.14	2.89	3.83	4.69
2	mar-23	2.46	2.89	4.1	4.73	2.34	2.81	3.55	4.37		2.77		4.69
3	mar-23	2.46	2.85	3.86	4.69	2.38	2.89	3.49	4.19	2.11	2.91		4.73
1	mar-23	2.42	2.85	4.02	4.69	2.38	2.97	3.55	4.37	2.14	2.89	3.82	4.69
2	mar-23	2.42		4.06	4.72	2.34	2.81	3.49	4.29	2.11	2.77		4.69
3	mar-23	2.42	2.93	4.02	4.73	2.3	2.73	3.59	4.19	2.03			4.69
1	apr-23	2.5	2.89	4.06	4.77	2.46	2.89	3.85	4.39	2.22	2.89		4.77
2	apr-23	2.46	2.89	4.1	4.69	2.38	2.85		4.39		2.77		4.69
3	apr-23	2.46		3.91	4.65	2.38	2.81	3.69	4.39	2.09	2.89		4.65
1	apr-23	2.5	2.89	4.06	4.73	2.42	2.89	3.9	4.34	2.23	2.89		4.77
2	apr-23	2.46	2.89		4.69	2.34	2.85	3.69	4.3		2.77		4.69
3	apr-23	2.46		3.95	4.65	2.38	2.87		4.3	2.07	2.89		4.65
1	apr-23	2.5	2.89	4.1	4.77	2.42	2.89	3.85	4.57	2.22	2.89		4.77
2	apr-23	2.46	2.89	4.1	4.69	2.38	2.85	3.87	4.3		2.81		4.69
3	apr-23	2.46		3.95	4.65		2.87		4.3		2.77		4.69
1	mag-23	2.42	2.85	4.02	4.8	2.42	2.77	3.69	4.77		2.81	3.55	4.77
2	mag-23	2.38	2.85	4.06	4.65	2.34	2.77	3.74		2.07	2.81		4.65

Monitoring activity on Fiorenza Node of A4 Highway

3	mag-23	2.46	2.89	4.1	4.73	2.85	3.84		2.23	2.89	4.73		
1	mag-23	2.42	2.85	4.02	4.84	2.42	2.77	3.65	4.69	2.23	2.81	3.55	4.77
2	mag-23	2.42	2.85	4.1	4.65	2.34	2.77	3.69		2.07	2.81	4.65	
3	mag-23	2.46	2.89	4.1	4.73	2.85				2.85	4.73		
1	mag-23	2.42	2.85	4.02	4.84	2.42	2.77	3.84	4.77	2.23	2.81	4.8	
2	mag-23	2.38	2.85	4.1	4.65	2.3	2.77	3.59		2.07	2.81	4.65	
3	mag-23	2.46	2.89	4.1	4.73	2.34	2.77	3.63		2.18	2.85	4.73	
1	giu-23	2.42	2.89	4.1	4.65	2.76	3.75	4.45		2.03	2.77	3.56	
2	giu-23	2.46	2.85	4.14	4.88	2.34	2.76	3.69		2.22	2.73		
3	giu-23	2.5	2.89	3.98	4.69	2.34	2.77	3.96	4.65	2.85	3.69	4.65	
1	giu-23	2.46	2.85	4.1		2.76	3.75	4.49		2.03	2.77	3.52	
2	giu-23	2.42	2.89	4.1	4.65	2.34	2.79	3.69		2.22	2.77		
3	giu-23	2.46	2.85	3.98	4.65	2.34	2.81	3.69	4.72	2.81	3.75	4.65	
1	giu-23	2.46	2.85	4.1		2.34		3.59		1.99	2.77	3.51	
2	giu-23	2.42	2.89	4.14	4.65	2.76	3.71	4.49		2.22	2.77	4.84	
3	giu-23	2.46	2.89	4.06	4.69	2.3	2.81	4.02		2.24	2.73		
1	lug-23	2.46	2.85	4.06	4.69	2.34	2.81	4.01	4.8	2.07	2.85	3.39	4.65
2	lug-23	2.46	2.85	4.06	4.8	2.38	2.89	4.04	4.41	2.29	2.81	4.73	
3	lug-23	2.42	2.85	4.1	4.84	2.38		3.98		2.77			
1	lug-23	2.46	2.85	4.06	4.69	2.34	2.81	4.04	4.8	2.03	2.85	3.39	4.65
2	lug-23		2.81	4.1	4.8	2.38		4.01		2.29	2.81	4.77	
3	lug-23	2.46	2.85	4.1	4.84	2.38	2.89	3.98		2.77			
1	lug-23	2.46	2.85	4.06	4.69	2.34	2.81	4.04	4.84	2.03	2.85	4.65	
2	lug-23		2.85	4.1	4.77	2.38	2.89	4.01		2.29	2.81	4.73	
3	lug-23	2.46	2.85	4.14	4.84	2.38		3.98		2.77			
1	ago-23	2.46	2.85	4.02	4.65	2.34	2.73	4.02		2.18	2.81	3.63	4.65
2	ago-23	2.46	2.85	4.06	4.53	2.34	2.77	4.02		2.22	2.81	3.59	4.69
3	ago-23	2.46	2.85	4.06	4.69	2.34	2.81	4.02	4.69	2.3	2.77	3.63	4.49
1	ago-23	2.46	2.89	4.02	4.65	2.34	2.77	4.06		2.22	2.81	3.63	4.65
2	ago-23	2.42	2.85	4.06	4.53	2.34	2.77	4.02		2.81	3.63	4.69	
3	ago-23	2.46	2.85	4.06	4.69	2.34	2.81	4.02		2.3	2.77	3.63	4.49
1	ago-23	2.46	2.89	4.06	4.69	2.34	2.77	4.06		2.18	2.77	4.69	
2	ago-23	2.46	2.85	4.06	4.53	2.34	2.89	4.02		2.34	2.77	3.63	4.49
3	ago-23	2.46	2.85	4.02	4.65	2.34	2.77	4.02		2.81	3.63	4.73	
1	set-23		2.85	4.02	4.61	2.38	2.85	3.71	4.38	2.14	2.81	3.51	4.53
2	set-23			4.14	4.69	2.38	2.89	3.76		2.14	2.81	3.67	4.65
3	set-23		2.89	4.06	4.69		2.85	3.76		2.81		4.65	
1	set-23	2.26	2.85	4.02	4.61	2.38	2.85	3.48	4.38	2.14	2.81	3.51	4.57
2	set-23			4.14	4.69	2.36	2.89	3.55		2.14	2.81	4.65	
3	set-23		2.89	4.1	4.69		2.81	3.55		2.81	3.67	4.65	
1	set-23			4.14	4.69	2.34	2.85	3.48	4.38			4.69	
2	set-23	2.46	2.85	4.02	4.65	2.34	2.89	3.55		2.77	3.67	4.65	
3	set-23		2.85	4.02	4.61		2.85	3.55		2.14	2.81	4.65	
1	ott-23	2.46	2.89	4.06	4.77	2.38	2.73	3.83		2.32	2.85	3.49	4.77
2	ott-23	2.5	2.89	4.02	4.73	2.38	2.81		4.39	2.08	2.89	3.55	4.73
3	ott-23	2.46	2.89	3.95	4.77	2.38	2.77	3.91	4.39	2.08	2.89	4.73	
1	ott-23	2.5	2.89	4.06	4.73	2.38	2.73	3.83		2.38	2.85	3.48	4.77
2	ott-23	2.5	2.89	4.06	4.73	2.38	2.77	3.91	4.39	2.07	2.89	3.55	4.69
3	ott-23	2.46	2.93	3.95	4.77	2.38	2.81	3.83	4.39	2.07	2.89	4.73	

Monitoring activity on Fiorenza Node of A4 Highway

1	ott-23	2.46	2.89	4.06	4.73	2.38	2.77	3.91	4.39	2.07	2.89	3.55	4.73
2	ott-23	2.5	2.89	4.06	4.69	2.34	2.81	4.01		2.07	2.89	3.79	4.73
3	ott-23	2.46	2.89	3.95	4.73	2.38	2.73	3.86			2.85		4.77
1	nov-23	2.5	2.93	4.1	4.73		2.77	3.86	4.29		2.85	3.74	4.77
2	nov-23	2.5	2.89	4.1	4.77		2.77	3.67		2.1	2.85	3.69	4.69
3	nov-23	2.5	2.89	4.1	4.73	2.41	2.81	3.71	4.49	2.1	2.85		4.54
1	nov-23	2.5	2.89	4.1	4.77		2.77	3.86	4.29		2.85	3.83	4.77
2	nov-23	2.5	2.93	4.1	4.69	2.39	2.77	3.67	4.29	2.07	2.81	3.75	4.73
3	nov-23	2.5	2.89	4.1	4.73		2.77	3.71	4.32	2.07	2.85		
1	nov-23	2.5	2.89	4.1	4.77	2.34	2.77	3.71	4.49		2.85	3.83	4.77
2	nov-23	2.5	2.93	4.1	4.73		2.77	3.59	4.31	2.07	2.85		4.53
3	nov-23	2.5	2.89	4.1	4.73		2.81	3.63		2.07	2.85	3.75	4.73
1	dic-23	2.5	2.93	4.14	4.8	2.38	2.94	3.69	4.29	2.1	2.93		4.8
2	dic-23		2.93	3.98	4.8	2.38	3.01	3.79	4.23		2.89	3.78	4.79
3	dic-23	2.5	2.89		4.77	2.38	2.89	3.75		2.1	2.93	3.81	4.79
1	dic-23	2.5	2.93	4.14	4.8	2.38	2.94	3.75	4.29	2.1	2.93		4.81
2	dic-23	2.5	2.93		4.77	2.38	3.03	3.79	4.26	2.1	2.93		4.8
3	dic-23		2.97	3.98	4.8	2.38	2.89	3.75			2.89	3.78	4.8
1	dic-23	2.5	2.93	4.14	4.8	2.27	2.93	3.87		2.1	2.93		4.8
2	dic-23	2.5	2.93		4.77	2.34	2.85	3.75		2.1	2.89		4.77
3	dic-23		2.97	3.95	4.8		2.97	3.69	4.29		2.89	3.79	4.77

5.1.1 Vertical direction (x)

223-S2-L/2 - Vertical direction

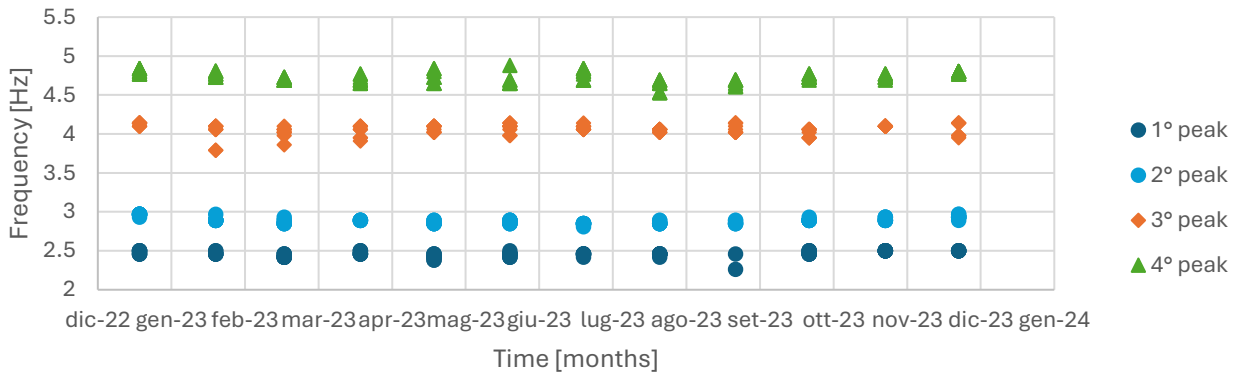

Figure 5-3: 223- S2 – L/2 - Natural frequencies obtained in vertical direction

5.1.2 Longitudinal direction (y)

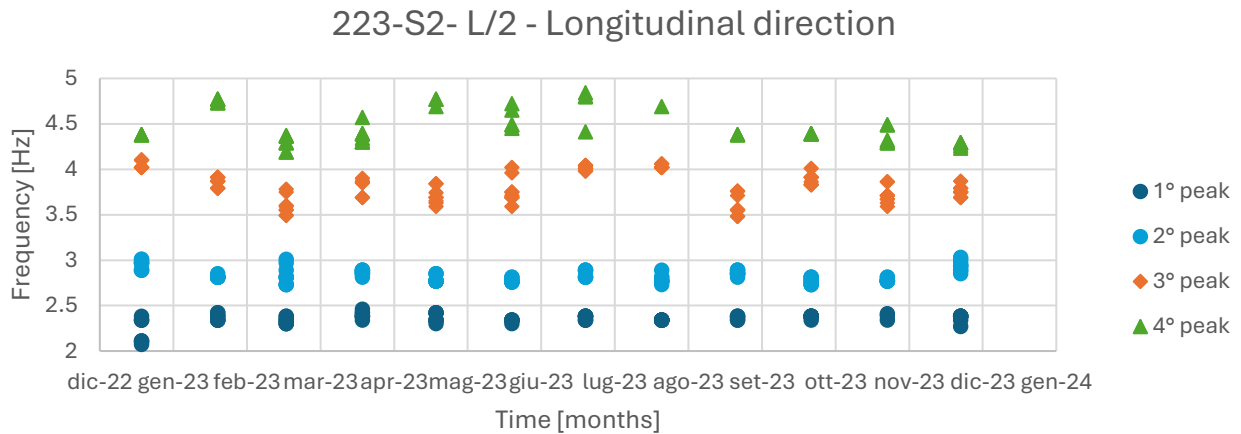

Figure 5-4: 223- S2 – L/2 - Natural frequencies obtained in longitudinal direction

5.1.3 Transverse direction (z)

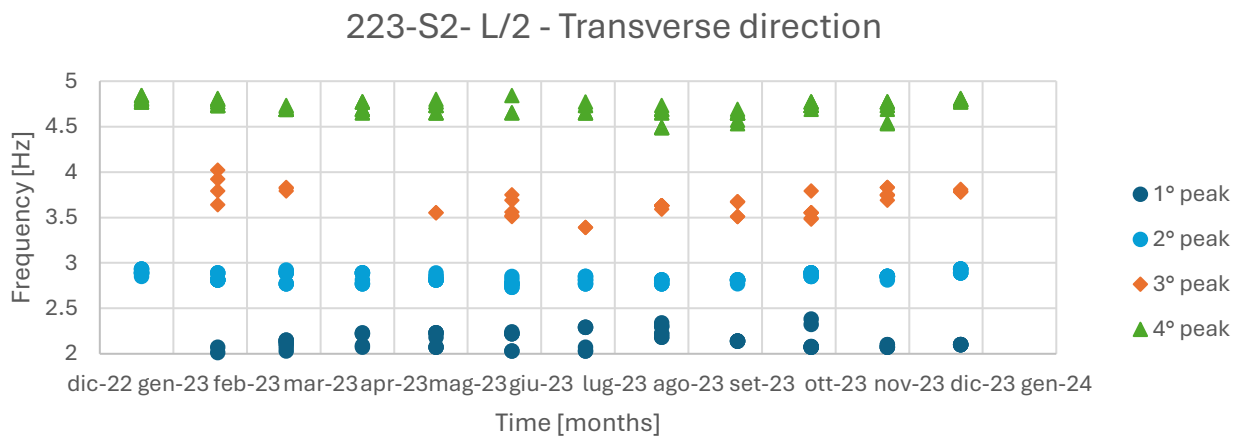

Figure 5-5: 223- S2 - L/2 - Natural frequencies obtained in transverse direction

5.2 223 SP2 L/4 Sensor 2BA63

All the obtained frequencies have been now classified and represented in such a way to obtain the variation of the values during the year. So, the peaks value has been separated and the representation for the vertical, longitudinal and transverse direction have been obtained.

Table 5-3 2023 natural frequencies [Hz] identified for sensor 2BA63 – 223 SP2 L/4

	Vertical direction				Longitudinal direction				Transverse direction			
	1° peak	2° peak	3° peak	4° peak	1° peak	2° peak	3° peak	4° peak	1° peak	2° peak	3° peak	4° peak
Numerosity	83	97	105	108	78	95	105	93	61	101	69	94
MEAN	2.46	2.89	4.05	4.73	2.44	2.88	4.05	4.71	2.17	2.82	3.78	4.69
SD	0.03	0.04	0.09	0.08	0.05	0.05	0.09	0.08	0.10	0.05	0.19	0.12
C.o.V.	1.1%	1.3%	2.2%	1.6%	2.0%	1.7%	2.1%	1.6%	4.8%	1.8%	4.9%	2.5%
Rating	80%	92%	93%	100%	70%	87%	93%	86%	44%	92%	50%	81%

Monitoring activity on Fiorenza Node of A4 Highway

1	gen-23	2.46	2.97	4.14	4.8	2.42	2.97	4.14	4.8	2.34	2.89		
2	gen-23		2.97	4.14	4.84	2.46	2.93	4.18	4.84		2.85	3.48	4.1
3	gen-23	2.46	2.97	4.1	4.8	2.46	2.89	4.14	4.8		2.85		4.1
1	gen-23	2.46	3.01	4.14	4.8	2.42	2.97	4.14	4.84	2.34	2.85		
2	gen-23			4.14	4.84		2.93	4.18	4.84		2.81	3.48	4.84
3	gen-23		2.93	4.1	4.8		2.93	4.1	4.8		2.85		4.77
1	gen-23	2.46	2.97	4.14	4.8	2.42	2.97	4.14	4.8	2.34	2.89		
2	gen-23			4.14	4.84		2.93	4.18	4.84			3.43	4.84
3	gen-23		2.97	4.14	4.8		2.97	4.1	4.8				
1	feb-23	2.46	2.89	3.86	4.77	2.42	2.89	3.91	4.77	2.26	2.85	3.82	4.73
2	feb-23	2.46	2.89	4.1	4.8	2.46		4.1	4.8	2.34	2.81	3.96	4.77
3	feb-23	2.5	2.89	4.06	4.73	2.46	2.85	4.06	4.73		2.81	3.89	4.73
1	feb-23	2.46	2.89	3.89	4.77	2.42	2.89	3.87	4.77	2.27	2.85	3.83	4.73
2	feb-23	2.46	2.93	4.1	4.8	2.46		4.1	4.8	2.3	2.81	4.02	4.77
3	feb-23	2.5	2.89	4.06	4.73	2.46	2.85	4.06	4.73		2.81	3.91	4.73
1	feb-23	2.5	2.89	4.06	4.73	2.42	2.89	3.87	4.77		2.85		4.8
2	feb-23	2.46	2.93	4.1	4.8	2.46	2.85	4.06	4.73	2.27	2.85	3.83	4.73
3	feb-23	2.46	2.93	3.89	4.77	2.5	2.89	4.1			2.81	3.9	4.73
1	mar-23	2.42	2.89	3.75	4.69	2.42	2.89	4.02	4.69	2.19	2.93	3.79	4.69
2	mar-23	2.46	2.89	4.06	4.73	2.42	2.89	4.1	4.73		2.77		4.69
3	mar-23	2.46	2.89	4.06	4.73			4.1	4.8	2.22	2.93		4.69
1	mar-23	2.42	2.89	3.64	4.69	2.42	2.89	3.64	4.69	2.18	2.92	3.78	4.69
2	mar-23	2.46	2.93	4.06	4.72	2.42	2.89	4.1	4.73		2.77		4.69
3	mar-23	2.46	2.89	4.06	4.72	2.46	2.89	4.06	4.73	2.22	2.92		4.69
1	mar-23	2.42	2.89	3.64	4.69	2.46		4.06	4.73	2.18	2.93	3.78	4.69
2	mar-23	2.42		4.06	4.73	2.42	2.89	3.64	4.69		2.77		4.69
3	mar-23	2.42	2.89	4.06	4.73	2.5	2.89	4.06	4.73	2.18	2.93		4.69
1	apr-23	2.5	2.89	4.06	4.73	2.5	2.89	3.98	4.73		2.85	3.84	4.77
2	apr-23	2.46	2.85	4.06	4.65	2.46		3.98	4.57	2.26	2.73	3.59	4.57
3	apr-23		2.85	3.98	4.65		2.81	4.02	4.61	2.02	2.85	3.84	4.77
1	apr-23	2.5	2.89	4.06	4.77	2.5	2.89	3.98			2.89	3.81	4.73
2	apr-23	2.46			4.65	2.46		4.02	4.61		2.77	3.55	4.57
3	apr-23		2.89	4.02	4.65		2.81	4.02	4.65	2.1	2.85		4.65
1	apr-23	2.5	2.89	4.06	4.73	2.46	2.89	3.98	4.73		2.85	3.84	4.77
2	apr-23	2.46	2.85	4.04	4.65	2.46		4.06	4.61		2.73	3.55	4.57
3	apr-23			4.02	4.65		2.81	4.02	4.65	2.1	2.89		4.65
1	mag-23	2.42	2.85	4.02	4.84	2.42	2.81	4.02	4.73	2.07	2.81	4.01	4.69
2	mag-23	2.42	2.85	4.02	4.65	2.38	2.81	4.06	4.65	2.07	2.77	4.09	4.65
3	mag-23	2.46	2.89	4.06	4.73	2.46	2.85	4.02	4.73	2.15	2.85		4.73
1	mag-23	2.42	2.85	4.02	4.84	2.42	2.81	4.02	4.73	2.07	2.81		4.69
2	mag-23	2.42	2.85	4.02	4.65	2.38	2.81	4.1	4.65	2.07	2.77	4.18	4.65
3	mag-23	2.46	2.89	4.06	4.73	2.46	2.89	4.02	4.73	2.18	2.85		4.73
1	mag-23	2.42	2.85	4.02	4.84	2.42	2.81	4.02	4.69	2.07	2.81		4.73
2	mag-23	2.42	2.85	4.02	4.65	2.38	2.81	4.1	4.65	2.07	2.77	4.18	4.65
3	mag-23	2.46	2.89	4.06	4.73	2.5	2.85	4.02	4.73	2.18	2.81		4.73
1	giu-23	2.42	2.85	4.1	4.65	2.59	2.97	4.02	4.57		2.77	3.59	
2	giu-23	2.46	2.85	4.14	4.88	2.46	2.85	4.14		2.18	2.77		
3	giu-23	2.46	2.89	3.95	4.69	2.46	2.89	3.98	4.69		2.81	3.75	4.65

Monitoring activity on Fiorenza Node of A4 Highway

1	giu-23	2.42	2.85	4.06	4.65	2.93	4.02	4.57	2.77	3.9			
2	giu-23	2.46	2.85	4.14	4.88	2.46	2.89	3.98	4.65	2.14	2.77	4.45	
3	giu-23	2.46	2.89	3.95	4.69	2.46	2.85	4.14		2.81	3.75	4.65	
1	giu-23	2.42	2.85	4.06	4.65	2.93	4.06	4.57		2.77	3.87		
2	giu-23	2.46	2.85	4.06	4.84	2.46	2.85	4.14		2.77		4.88	
3	giu-23		2.89	4.14	4.69	2.89	4.1	4.69	2.26	2.73			
1	lug-23	2.46	2.85	4.06	4.69	2.38	2.81	4.09	2.11	2.77	3.92	4.65	
2	lug-23		2.85	4.06	4.77	2.42	2.89	4.02	4.65	2.24	2.81	4.09	4.73
3	lug-23	2.42	2.89	4.1	4.84	2.34	2.96	4.09		2.29	2.77	4.09	
1	lug-23	2.42	2.85	4.06	4.65	2.34	2.81	4.14		2.3	2.81	4.09	4.73
2	lug-23		2.85	4.1	4.8	2.34	2.85	4.02	4.65	2.1	2.77		4.65
3	lug-23	2.42	2.89	4.1	4.8	2.42	2.97	4.1		2.31	2.77	4.14	
1	lug-23	2.46	2.85	4.06	4.65	2.34	2.81	4.14		2.11	2.77		4.65
2	lug-23		2.81	4.1	4.77	2.42	2.85	4.02	4.69	2.3	2.81	4.14	4.73
3	lug-23	2.46	2.89	4.1	4.8	2.34	2.97	4.1		2.34	2.77	4.21	
1	ago-23	2.46	2.85	4.02	4.65	2.38	2.85	4.06	4.53	2.07	2.81	3.67	4.65
2	ago-23	2.46		4.06	4.65	2.46	2.85	4.02	4.65	2.24	2.77	3.61	4.53
3	ago-23		2.85	4.06	4.53		2.89	4.06	4.65			3.75	4.65
1	ago-23	2.46	2.89	4.02	4.65	2.38	2.85	4.06	4.53	2.07	2.81		4.65
2	ago-23	2.46		4.06	4.65	2.46	2.82	4.02	4.65	2.24	2.81	3.67	4.53
3	ago-23	2.46	2.85	4.06	4.49		2.85	4.06	4.61				4.69
1	ago-23	2.42	2.85	4.06	4.53	2.34	2.85	4.06	4.53	2.24	2.77	3.67	4.53
2	ago-23		2.89	4.06	4.65		2.89	4.06	4.61				4.69
3	ago-23	2.46	2.85	4.02	4.65		4.1		2.07	2.81		4.65	
1	set-23		2.85	4.02	4.57	2.5	2.85	4.57	2.07	2.81	3.59	4.49	
2	set-23			4.1	4.69		2.89	4.06	4.65		2.77	3.64	4.65
3	set-23		2.89	4.06	4.73	2.46	2.81	4.06	4.69	2.07	2.77	3.71	4.65
1	set-23		2.85	4.02	4.69		2.85	4.02	4.57	2.1	2.81	3.59	4.49
2	set-23			4.1	4.61		2.85	4.06	4.65	1.95	2.77	3.59	
3	set-23		2.89	4.1	4.69	2.46	2.81	4.06	4.69	2.07	2.77	3.63	4.65
1	set-23			4.1	4.69		2.85	4.02	4.57				4.69
2	set-23		2.85	4.02	4.61			4.06	4.69	1.95	2.77	3.6	
3	set-23	2.42	2.85	4.02	4.65		2.89	4.14	4.65	2.07	2.77	3.63	4.65
1	ott-23	2.46	2.89	4.1	4.73	2.46	2.89	4.06	4.73	2.15	2.86	3.67	4.73
2	ott-23	2.46	2.93	3.95	4.77	2.38	2.77	3.83	4.77		2.81	3.83	4.8
3	ott-23	2.46	2.89	4.06	4.69	2.46	2.85	4.02	4.73		2.73	3.64	4.69
1	ott-23	2.46	2.89	4.06	4.73	2.46	2.89	4.06	4.73	2.14	2.89	3.69	4.73
2	ott-23	2.46	2.89	3.95	4.76	2.42	2.77	3.89	4.77		2.81	3.83	4.8
3	ott-23	2.46	2.89	4.02	4.69	2.42	2.85	4.06	4.69	2.11	2.89	3.94	4.77
1	ott-23	2.46	2.89	4.1	4.77	2.46	2.89	4.06	4.73		2.81	3.83	4.8
2	ott-23	2.46	2.89	3.95	4.77	2.42	2.89	4.06	4.69	2.07	2.89	3.64	4.77
3	ott-23	2.46	2.89	4.06	4.65			4.06	4.73		2.81	3.69	4.69
1	nov-23	2.46	2.89	4.1	4.77	2.5	2.89	4.1	4.69	2.3	2.81	3.71	4.69
2	nov-23	2.5	2.93	4.14	4.73			4.1	4.77		2.81	3.55	4.69
3	nov-23	2.5	2.89	4.06	4.69	2.5	2.93				2.81	3.82	4.77
1	nov-23	2.46	2.89	4.1	4.77	2.5	2.89	4.1	4.65	2.3	2.81	3.71	4.69
2	nov-23	2.5	2.89	4.1	4.77			4.1	4.77		2.81	3.79	4.77
3	nov-23	2.5	2.93	4.18	4.73	2.5	2.93	4.06			2.81		4.73
1	nov-23	2.46	2.93	4.1	4.77			4.1	4.77		2.85	3.83	4.77

Monitoring activity on Fiorenza Node of A4 Highway

2	nov-23	2.5	4.02	4.84	2.5	2.93	4.77	2.81	3.59	4.69		
3	nov-23	2.5	2.93	4.18	4.73	2.89	4.1	2.3	2.81	4.49		
1	dic-23	2.54	2.93	4.14	4.77	2.5	2.93	4.1	4.8	2.93	4.8	
2	dic-23	2.93	3.98	4.8	4.77	2.93	4.14	4.73	2.85	3.69	4.77	
3	dic-23	2.46	2.93	4.14	4.73	2.97	3.95	4.8	2.89	4.77		
1	dic-23	2.5	2.93	4.14	4.77	2.5	2.93	4.1	4.77	2.07	2.93	4.8
2	dic-23	2.46	2.93	4.77	4.77	2.97	4.14	4.77	2.85	3.69	4.77	
3	dic-23	2.93	4.14	4.73	2.46	2.93	4.06	4.77	2.89	4.77		
1	dic-23	2.5	2.93	4.14	4.8	2.5	2.93	4.1	4.77	2.1	2.93	4.8
2	dic-23	2.97	3.98	4.8	4.77	2.93	4.14	4.77	2.89	3.69	4.77	
3	dic-23	2.46	2.93	4.8	2.46	2.93	4.06	4.77	4.77			

5.2.1 Vertical direction (x)

223-S2-L/4 - Vertical direction

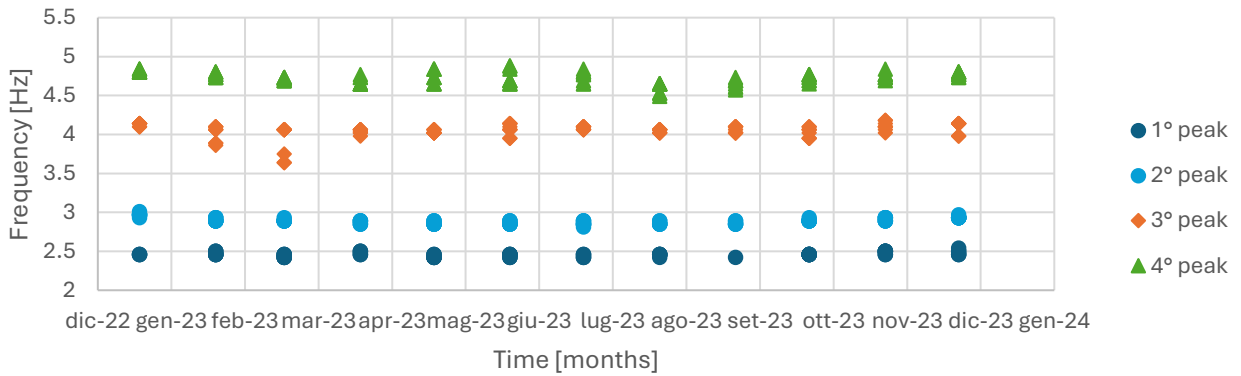

Figure 5-6: 223- S2 – L/4 - Natural frequencies obtained in vertical direction

5.2.2 Longitudinal direction (y)

223-S2- L/4 - Longitudinal direction

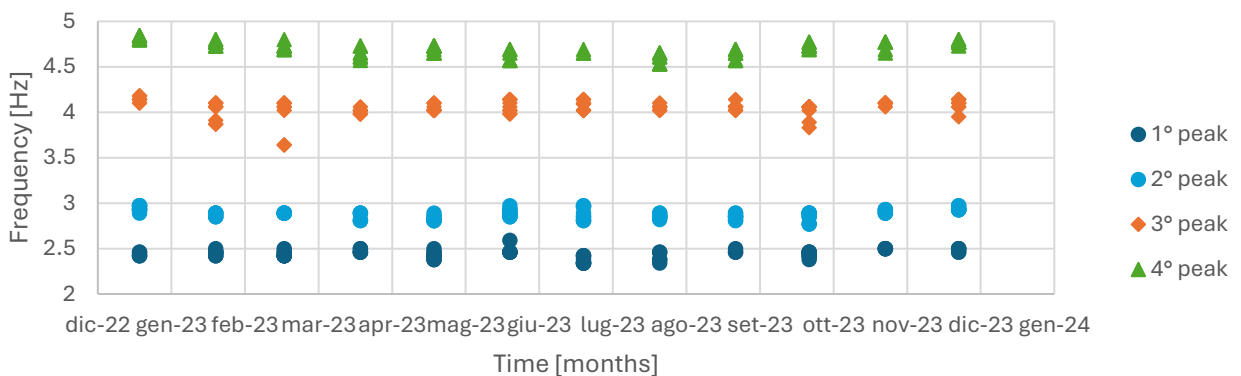

Figure 5-7: 223 – S2 – L/4 - Natural frequencies obtained in longitudinal direction

5.2.3 Transverse direction (z)

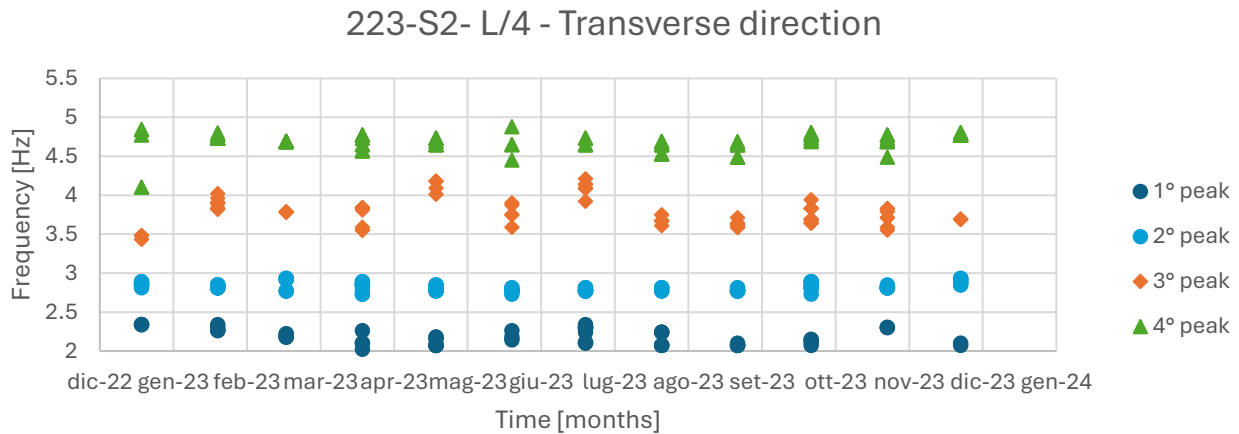

Figure 5-8: 223- S2 - L/4 - Natural frequencies obtained in transverse direction

5.3 223 SP2 L/8 Sensor 31205

All the obtained frequencies have been now classified and represented in such a way to obtain the variation of the values during the year. So, the peaks value has been separated and the representation for the vertical, longitudinal and transverse direction have been obtained.

Table 5-4 2023 natural frequencies [Hz] identified for sensor 31205 – 223 SP2 L/8

	Vertical direction				Longitudinal direction				Transverse direction			
	1° peak	2° peak	3° peak	4° peak	1° peak	2° peak	3° peak	4° peak	1° peak	2° peak	3° peak	4° peak
Numerosity	78	91	103	108	82	89	107	92	71	102	83	88
MEAN	2.46	2.88	4.05	4.73	2.45	2.87	4.04	4.69	2.16	2.80	3.73	4.61
SD	0.03	0.04	0.09	0.08	0.05	0.04	0.10	0.09	0.08	0.05	0.19	0.17
C.o.V.	1.4%	1.2%	2.3%	1.6%	2.1%	1.5%	2.4%	1.9%	3.8%	1.8%	5.2%	3.6%
Rating	74%	87%	90%	100%	73%	83%	93%	83%	55%	93%	59%	69%
1	gen-23	2.97	4.14	4.8	2.38	2.97	4.14	4.84	2.07	2.85		4.6
2	gen-23		2.97	4.1	4.8		2.93	4.14	4.8	2.07	2.85	4.69
3	gen-23	2.5	2.97	4.06	4.8	2.5		4.06	4.8		2.85	4.73
1	gen-23		2.93	4.14	4.8	2.38	2.85		4.61	2.38	2.97	4.8
2	gen-23			4.14	4.8		2.81	3.79	4.65		2.93	4.77
3	gen-23			4.14	4.8		2.85	4.02				4.8
1	gen-23		2.97	4.14	4.8	2.38	2.97	4.14	4.8	2.38	2.85	4.61
2	gen-23				4.8		2.89	4.14	4.77		2.85	3.83
3	gen-23	2.46	2.97	4.1	4.8			4.14	4.81			3.83
1	feb-23	2.46	2.89	4.1	4.8	2.46	2.85	4.1	4.8	2.26	2.85	3.83
2	feb-23	2.46	2.89	3.82	4.77	2.46	2.89	3.91	4.77	2.26	2.81	4.8
3	feb-23	2.46	2.89	4.06	4.73	2.5	2.85	4.06	4.73		2.81	4.77
1	feb-23	2.46	2.89	4.1	4.8	2.46		4.1	4.8	2.26	2.85	3.83
2	feb-23	2.46	2.89	3.81	4.77	2.46	2.89	3.91	4.77	2.26	2.77	4.73
3	feb-23	2.46	2.89	4.06	4.73	2.46	2.85	4.06	4.73		2.77	4.73

Monitoring activity on Fiorenza Node of A4 Highway

1	feb-23	2.46	2.89	4.06	4.73	2.5	2.89	4.06	4.73	2.26	2.85	3.83	
2	feb-23	2.46	2.89	4.1	4.8		2.93	4.14	4.77	2.26	2.85		
3	feb-23		2.93		4.8	2.46	2.89	3.87	4.77		2.81	4.02	4.77
1	mar-23	2.42	2.89	3.75	4.69	2.42	2.85	3.81	4.69	2.18	2.93	3.79	4.65
2	mar-23	2.46	2.85	3.75	4.69	2.46		3.75	4.69	2.22	2.81	3.59	4.69
3	mar-23	2.46	2.89	4.01	4.69	2.5		4.06	4.8		2.81		4.69
1	mar-23	2.42	2.89	3.75	4.69	2.42	2.85	3.75	4.69	2.19	2.93	3.79	4.65
2	mar-23	2.46	2.85	3.75	4.69	2.46		3.71	4.69	2.22	2.81	3.55	4.68
3	mar-23	2.38	2.85	4.01	4.73	2.46	2.89	4.06	4.73		2.81	3.63	4.73
1	mar-23	2.42	2.89	3.75	4.69	2.42	2.85	3.75	4.69	2.18	2.93	3.78	4.65
2	mar-23	2.46		4.06	4.73			4.06	4.73	2.07	2.77		4.69
3	mar-23	2.42	2.89	4.06	4.73	2.46		3.74	4.69	2.23	2.81	3.55	4.69
1	apr-23	2.5	2.89		4.8	2.46	2.89	4.01	4.38	2.14	2.73		4.29
2	apr-23	2.42			4.61	2.46		3.98	4.53		2.85	3.59	4.8
3	apr-23			4.1	4.8		2.81	4.02	4.65		2.81	3.94	4.8
1	apr-23	2.5	2.89	4.06	4.77	2.46	2.89	4.02	4.38	2.18	2.73		4.29
2	apr-23	2.42			4.57	2.46		3.98	4.53		2.85	3.51	4.8
3	apr-23	2.42		4.1	4.77		2.77	4.02	4.65		2.85		
1	apr-23	2.5	2.89	4.06	4.73	2.46	2.89	4.02	4.41		2.73		4.29
2	apr-23			4.02	4.61	2.46		3.98	4.53		2.85	3.51	4.77
3	apr-23		2.89	3.98	4.69		2.85	4.02	4.69	2.03	2.77		4.69
1	mag-23	2.42	2.85	4.02	4.84	2.42	2.81	4.02		2.07	2.81	3.98	4.65
2	mag-23	2.42	2.85	4.02	4.65	2.42	2.85	4.02	4.65	2.07	2.77	4.04	4.61
3	mag-23	2.46	2.89	4.1	4.73	2.5	2.89	4.1	4.73	2.07	2.81		4.69
1	mag-23	2.42	2.85	4.02	4.84	2.42	2.81	4.02		2.07	2.81	3.98	4.65
2	mag-23	2.42	2.85	4.06	4.65	2.42	2.85	3.98	4.65	2.07	2.77	4.04	4.61
3	mag-23		2.85	3.98	4.73	2.46	2.89	4.1	4.73	2.15	2.81		4.73
1	mag-23	2.42	2.85	4.02	4.84	2.42	2.81	4.02		2.1	2.81	3.98	4.65
2	mag-23	2.42	2.85	3.98	4.65	2.42	2.81	4.02	4.65	2.11	2.77	4.08	4.61
3	mag-23	2.46	2.89	4.1	4.73	2.5	2.89	4.06	4.73	2.15	2.73	4.08	4.61
1	giu-23	2.46	2.89	4.02	4.65	2.61	2.93	3.95	4.65	2.15	2.77	3.55	
2	giu-23	2.46	2.85	3.98	4.65	2.46	2.89	4.02	4.65			3.75	4.65
3	giu-23	2.46	2.85	4.1	4.88	2.46	2.85	4.14		2.19	2.77		
1	giu-23	2.46	2.89	4.02	4.65	2.61	2.93	3.95	4.65		2.77	3.55	
2	giu-23	2.46	2.85	4.14	4.88	2.46	2.89	3.98	4.65			3.75	4.65
3	giu-23	2.46	2.85	3.98	4.65	2.46	2.85	4.14		2.19	2.77	3.48	4.8
1	giu-23	2.46	2.85	4.1	4.92	2.46	2.85	4.14		2.15	2.77	3.55	
2	giu-23	2.46	2.85	3.98	4.65	2.61	2.93	3.95	4.65	2.19	2.77	3.44	4.65
3	giu-23		2.85	4.06	4.69		2.85	4.1	4.69			3.75	4.8
1	lug-23	2.46	2.85	4.1	4.69	2.42	2.89	4.02	4.65	2.1	2.73	3.43	
2	lug-23		2.81	4.1	4.8	2.42	2.81	4.14		2.3	2.77		4.73
3	lug-23	2.46	2.85	4.14	4.84	2.38		4.1		2.34	2.73		4.29
1	lug-23		2.85	4.1	4.65	2.34	2.81	4.14		2.07	2.73	3.44	
2	lug-23	2.46	2.85	4.14	4.84	2.42	2.89	3.98	4.65	2.3	2.77		4.69
3	lug-23		2.85	4.1	4.77	2.42		4.1		2.3	2.73		4.22
1	lug-23		2.85	4.1	4.65	2.38	2.81	4.14		2.11	2.73	3.4	
2	lug-23		2.81	4.1	4.77	2.42	2.85	4.02	4.65	2.3	2.81		4.29
3	lug-23	2.46	2.85	4.14	4.84	2.42		4.1			2.73		4.34
1	ago-23	2.46	2.85	3.98	4.65	2.38	2.85	4.06	4.53		2.77		4.53

Monitoring activity on Fiorenza Node of A4 Highway

2	ago-23	2.46		4.06	4.69	2.46	2.85	4.02	4.65	2.14	2.77	3.59	4.65
3	ago-23	2.46	2.85	4.06	4.53	2.42		4.06	4.69	2.14	2.77	3.78	4.65
1	ago-23	2.46	2.89	4.02	4.65	2.38	2.85	4.06	4.53		2.73	3.59	4.53
2	ago-23	2.46		4.02	4.65	2.46	2.85	4.02	4.65	2.14	2.77		4.65
3	ago-23	2.46	2.89	4.1	4.69	2.46		4.06	4.69		2.77	3.79	4.65
1	ago-23	2.46		4.06	4.65	2.34	2.85	4.06	4.53	2.11	2.77	3.59	4.53
2	ago-23	2.46	2.85	4.06	4.53	2.46	2.85	4.1			2.81	3.87	4.69
3	ago-23	2.46	2.85	4.02	4.65		2.85	4.06	4.57				
1	set-23		2.85	4.02	4.61		2.85	4.02	4.61	2.03	2.77	3.48	4.42
2	set-23		2.89	4.1	4.69		2.89	4.06	4.69	2.1	2.77	3.55	
3	set-23			4.06	4.69		2.85	4.06	4.69	2.03	2.77	3.78	4.69
1	set-23	2.3	2.85	4.02	4.57	2.38	2.85	4.02	4.61		2.77	3.48	4.34
2	set-23			4.1	4.69		2.89	4.06	4.69	2.11	2.77	3.55	
3	set-23		2.89	4.06	4.69		2.85	4.06	4.73		2.77	3.63	4.38
1	set-23			4.14	4.69	2.34	2.85	4.02	4.61		2.77	3.63	4.65
2	set-23	2.34	2.85	4.02	4.61			4.1	4.69	2.11	2.77	3.55	4.34
3	set-23	2.42	2.89	4.02	4.65		2.89	4.06	4.69	2.07	2.77	3.48	4.38
1	ott-23	2.46	2.89	4.06	4.73	2.46	2.89	3.98	4.69	2.21	2.81	3.51	4.42
2	ott-23	2.46	2.89	3.94	4.77	2.38	2.89	4.06	4.77		2.81	3.76	
3	ott-23	2.46	2.89	4.02	4.69	2.46	2.77	4.06	4.77	2.1	2.89	3.55	4.34
1	ott-23	2.46	2.89	4.06	4.73	2.46	2.89	4.02	4.77	2.26	2.81	3.55	4.34
2	ott-23	2.46	2.89	3.95	4.77	2.46	2.85	3.98	4.77		2.77	3.78	
3	ott-23	2.46	2.89	4.02	4.69	2.38	2.73	4.1	4.73	2.11	2.89	3.51	4.65
1	ott-23	2.5	2.89	4.06	4.73	2.46	2.89	4.06	4.77		2.77	3.78	4.88
2	ott-23	2.46	2.89	4.02	4.65	2.46	2.85	3.98	4.69		2.77	3.78	4.57
3	ott-23	2.46		3.95	4.77	2.46		4.02	4.73	2.11	2.89	3.55	4.69
1	nov-23		2.89	4.14	4.77	2.5	2.89	4.1	4.69	2.14	2.77	3.67	4.36
2	nov-23	2.5	2.93	4.1	4.69		2.89	4.1	4.77		2.81	3.59	4.73
3	nov-23	2.5	2.89	4.14	4.73	2.5	2.93	4.1			2.81		4.49
1	nov-23		2.89	4.14	4.77	2.5	2.89	4.1	4.69	2.15	2.77	3.63	4.3
2	nov-23	2.5	2.89	4.14	4.69		2.93	4.1	4.77	2.11	2.81	3.59	4.69
3	nov-23	2.5	2.93	4.14	4.69	2.5	2.89	4.1		2.11	2.81	3.59	4.49
1	nov-23		2.89	4.1	4.77		2.89	4.1	4.77	2.15	2.77	3.67	4.29
2	nov-23	2.5	2.93	4.14	4.77	2.5	2.93	4.1	4.73	2.07	2.81		4.59
3	nov-23	2.5		4.02	4.84		2.89	4.14	4.77		2.81	3.59	4.69
1	dic-23	2.5	2.93	4.14	4.8	2.46	2.93	4.14	4.77	2.14	2.85	3.78	
2	dic-23		2.93	4.02	4.73	2.5	2.93	3.98	4.77	2.14	2.85	3.67	4.77
3	dic-23	2.46	2.93	4.14	4.77			4.14	4.77	2.1	2.85		4.8
1	dic-23	2.5	2.93	4.14	4.8	2.5	2.93	4.14	4.77	2.11	2.85	3.84	4.8
2	dic-23	2.46	2.93	3.98	4.77	2.46	2.93	3.98	4.77	2.15	2.81	3.67	4.77
3	dic-23		2.93	4.14	4.73		2.93	4.14	4.77		2.85	3.75	4.53
1	dic-23	2.5	2.93	4.1	4.8	2.5	2.93	4.14	4.8	2.11	2.85	3.84	4.8
2	dic-23	2.46	2.93	3.98	4.77	2.46	2.93	4.02	4.77	2.18	2.85	3.67	4.77
3	dic-23		2.89	4.14	4.73		2.89	4.14	4.77	2.14	2.81	3.87	4.34

5.3.1 Vertical direction (x)

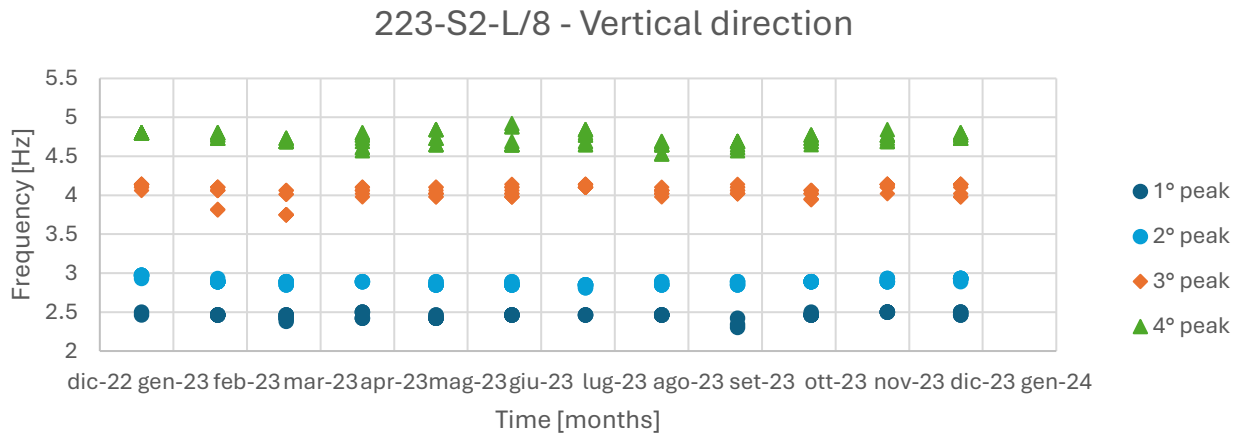

Figure 5-9: 223 – S2 – L/8 - Natural frequencies obtained in vertical direction

5.3.2 Longitudinal direction (y)

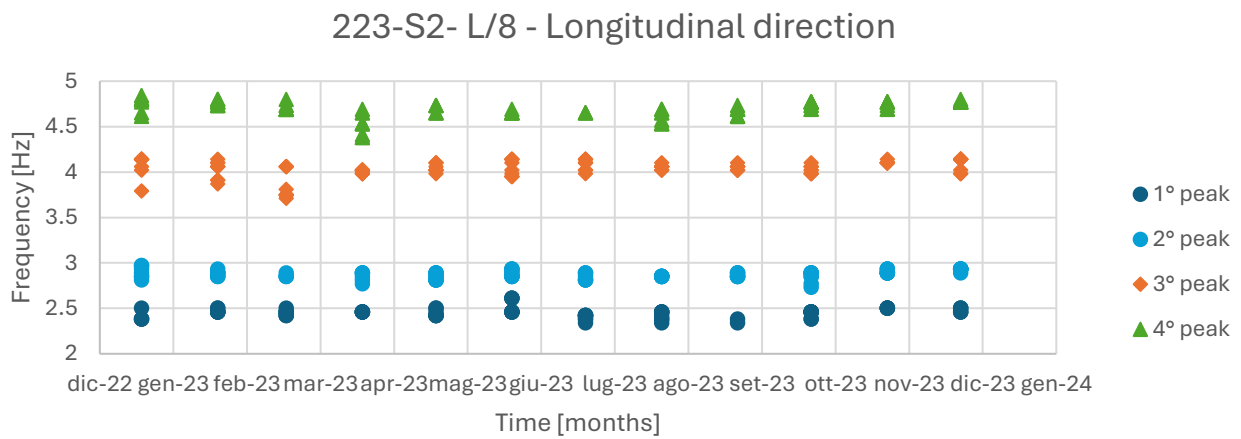

Figure 5-10: 223 – S2 – L/8 - Natural frequencies obtained in longitudinal direction

5.3.3 Transverse direction (z)

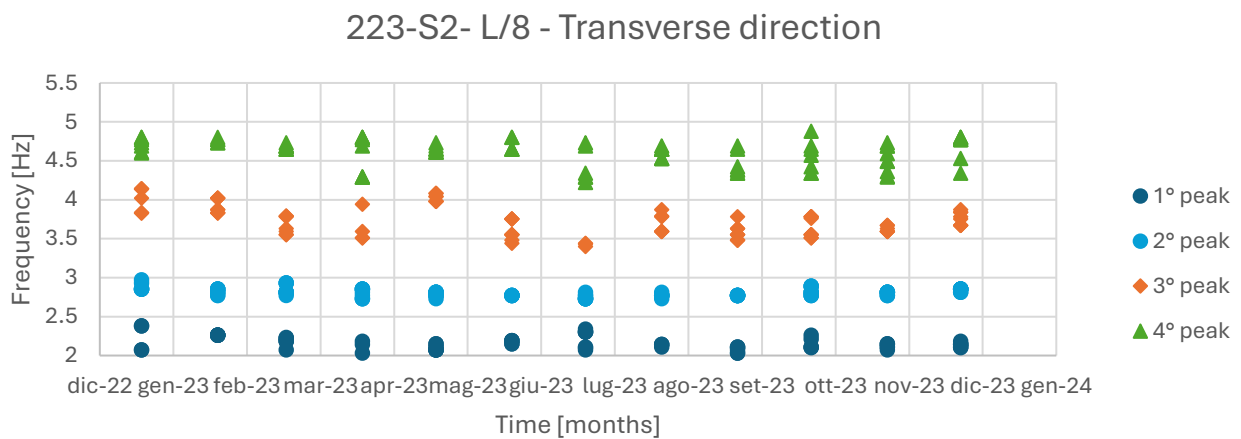

Figure 5-11: 223- S2 - L/8 - Natural frequencies obtained in transverse direction

5.4 223 SP2 West pier Sensor 319BC

All the obtained frequencies have been now classified and represented in such a way to obtain the variation of the values during the year. So, the peaks value has been separated and the representation for the vertical, longitudinal and transverse direction have been obtained.

Table 5-5 2023 natural frequencies [Hz] identified for sensor 319BC – 223 SP2 West pier

	Vertical direction				Longitudinal direction				Transverse direction			
	1° peak	2° peak	3° peak	4° peak	1° peak	2° peak	3° peak	4° peak	1° peak	2° peak	3° peak	4° peak
Numerosity	39	90	101	105	62	83	100	90	49	105	93	82
MEAN	2.33	2.84	3.98	4.71	2.45	2.87	4.05	4.72	2.25	2.81	3.74	4.41
SD	0.17	0.06	0.14	0.12	0.04	0.06	0.08	0.07	0.14	0.05	0.18	0.19
C.o.V.	7.1%	2.1%	3.6%	2.5%	1.8%	2.1%	1.9%	1.5%	6.1%	1.9%	4.7%	4.2%
Rating	26%	84%	84%	95%	59%	78%	95%	89%	34%	100%	71%	65%
1 gen-23	2.14	2.85	4.14	4.8	2.38	2.93	4.14	4.8	2.3	2.81	3.83	4.35
2 gen-23	2.38	2.89	4.14	4.8			4.1	4.84	1.95	2.85	4.01	4.65
3 gen-23		2.93	4.1	4.8		2.93	4.1	4.77	2.34	2.89	3.98	
1 gen-23		2.85	4.14	4.8	2.38	2.93	4.14	4.8		2.81	3.83	4.39
2 gen-23	2.34	2.89	4.14	4.8			4.14	4.84		2.85	3.98	4.65
3 gen-23		2.93	4.1	4.8		2.93	4.1	4.77	2.34	2.85	3.98	4.45
1 gen-23		2.93	4.14	4.77	2.38	2.93	4.14	4.8	2.5	2.85	3.83	
2 gen-23	2.38	2.89	4.14	4.8		2.93	4.14	4.77		2.85	3.9	4.53
3 gen-23		2.93	4.1	4.8			4.1	4.84	2.3	2.89	3.98	
1 feb-23		2.89	3.83	4.73	2.46		4.06	4.8	2.34	2.89	3.83	4.77
2 feb-23		2.81	4.06	4.8	2.46	2.89	3.91	4.77		2.77	3.98	
3 feb-23		2.81	3.83	4.73	2.5	2.93	4.06	4.73		2.77	3.98	
1 feb-23		2.89	3.83	4.8	2.46		4.06	4.8	2.34	2.85	3.83	4.77
2 feb-23		2.85	4.06	4.8	2.46	2.89	3.91	4.77		2.81	3.98	
3 feb-23		2.85	3.79	4.8	2.5	2.93	4.1	4.73		2.81	4.02	
1 feb-23		2.85	4.06	4.8	2.46	2.89	4.06	4.73	2.34	2.85	3.83	4.76
2 feb-23		2.89	3.83	4.77	2.46	2.89	3.91	4.77		2.81	4.01	
3 feb-23		2.85	3.83	4.8	2.46		4.06	4.8		2.81	4.02	4.72
1 mar-23	2.38	2.81	3.79	4.69	2.42	2.85	4.02	4.69	2.19	2.93	3.79	4.29
2 mar-23		2.93	3.67	4.65	2.46		3.71	4.69	2.46	2.81	3.63	4.34
3 mar-23	2.46	2.85	4.1	4.73	2.46	2.89	4.06	4.73		2.85	3.67	
1 mar-23	2.38	2.81	3.79	4.69	2.42	2.85	4.02	4.69	2.18	2.93	3.79	4.29
2 mar-23		2.93	3.67	4.69	2.46		3.71	4.69	2.39	2.81	3.63	4.34
3 mar-23	2.46	2.85	4.06	4.73	2.46	2.89	4.06	4.73		2.85	3.67	
1 mar-23	2.42	2.81	3.79	4.69	2.42	2.85	4.02	4.69	2.18	2.93	3.79	4.29
2 mar-23			4.06	4.73	2.46		3.71	4.69		2.81	3.63	4.34
3 mar-23		2.93	3.67	4.65	2.38		4.06	4.69	2.18	2.77		
1 apr-23	2.51	2.89	4.1	4.8	2.5	2.89		4.77	2.46	2.89	3.55	
2 apr-23			4.06	4.8			4.1	4.8		2.81		4.29
3 apr-23		2.81	3.9	4.65		2.85	4.02	4.65		2.81	3.98	
1 apr-23	2.54	2.89	4.1	4.77	2.5	2.89		4.77	2.46	2.89	3.55	4.29
2 apr-23		2.77	3.87	4.65				4.8		2.85		4.29
3 apr-23			4.06	4.8		2.85	4.02			2.77	3.82	

Monitoring activity on Fiorenza Node of A4 Highway

1	apr-23	2.5	2.89	4.1	4.77	2.5	2.89	4.77	2.46	2.77	3.52	4.29	
2	apr-23		2.85		4.69		2.85	4.1	4.69		2.89	3.55	4.29
3	apr-23		2.73	4.17	4.65		2.81	4.02	4.65		2.77	3.82	4.34
1	mag-23	2.42	2.85	4.02	4.88	2.42	2.85	4.02		2.38	2.77	3.55	4.73
2	mag-23	2.1	2.85	4.06	4.65	2.38	2.85	4.02	4.65	2.1	2.77		
3	mag-23			4.1	4.69		2.85	4.02	4.73		2.77	3.55	
1	mag-23	2.42	2.82	4.02	4.88	2.42	2.81	4.02		2.38	2.77	3.55	4.73
2	mag-23	2.07	2.82	4.02	4.65	2.38	2.81	4.06	4.65	2.11	2.77	4.01	
3	mag-23			4.1	4.73		2.85	4.06	4.73		2.77	3.78	4.34
1	mag-23	2.42	2.81	4.02	4.84	2.42	2.81	4.02		2.38	2.77	3.55	4.73
2	mag-23	2.07	2.81	4.1	4.65	2.42	2.81	4.06	4.65	2.11	2.77	4.01	4.34
3	mag-23			4.1	4.73			4.06	4.73		2.77	3.51	4.34
1	giu-23		2.77	3.87	4.53		2.66	4.02	4.65		2.77	3.48	4.1
2	giu-23			3.75	4.73	2.46	2.89	3.98	4.69		2.77	3.71	4.69
3	giu-23			3.48	4.69		2.89	4.06	4.69	2.23	2.77	3.67	4.3
1	giu-23		2.77	3.87	4.53		2.66	4.1	4.65		2.77	3.48	4.1
2	giu-23		2.93	3.74	4.73	2.42	2.85	3.98	4.69		2.77	3.71	4.65
3	giu-23	2.46	2.77	4.1	4.96		2.85	4.1	4.69	2.18	2.73	3.63	4.3
1	giu-23		2.77	3.87	4.53		2.66	4.06	4.65		2.77	3.48	4.1
2	giu-23			3.75	4.73	2.42		4.1		2.18	2.77	3.63	4.29
3	giu-23		2.85	4.06	4.73		2.85	4.06	4.69		2.73	3.71	4.68
1	lug-23	2.07	2.81	4.06	4.69		2.85	4.02	4.65	2.11	2.77	3.4	4.26
2	lug-23	2.38	2.73	4.1			2.81			2.3	2.81		4.14
3	lug-23	2.34	2.77	4.06	4.8	2.38		4.1			2.73		4.26
1	lug-23	2.34	2.73	4.1			2.85	4.02	4.65	2.1	2.77	3.4	4.26
2	lug-23	2.07	2.81	4.02	4.69		2.81			2.3	2.81		4.26
3	lug-23	2.3	2.77	4.02	4.84	2.38	3.01	4.1			2.73		4.14
1	lug-23	2.07	2.81	4.06	4.69		2.85	4.02	4.65	2.07	2.77	3.4	4.26
2	lug-23	2.38	2.73	4.1			2.81			2.3	2.81		4.14
3	lug-23	2.34	2.77	4.06	4.84	2.38		4.1			2.73		4.26
1	ago-23	2.34	2.73	4.02	4.49	2.46	2.85	4.02	4.65	2.34	2.73	3.59	4.53
2	ago-23	1.95	2.77	4.06	4.69	2.38	2.89	4.06	4.49		2.77		4.61
3	ago-23		2.85	3.83	4.77	2.46		4.06	4.69		2.77	3.87	
1	ago-23	2.34	2.77	4.02	4.49	2.46	2.85	4.02	4.65	2.3	2.77	3.59	4.53
2	ago-23	1.95	2.89	4.06	4.69	2.34	2.85	4.06	4.53		2.77	3.98	4.61
3	ago-23	2.38	2.81	3.83	4.77	2.46		4.06	4.65		2.77	3.86	
1	ago-23	2.3	2.77	4.02	4.49	2.34	2.85	4.06	4.49	2.3	2.77	3.59	4.53
2	ago-23			4.1	5	2.42	2.89	4.1			2.77	3.83	4.22
3	ago-23		2.81	4.02	4.69		2.85	4.1			2.73	3.83	
1	set-23		2.85	3.98	4.38		2.85	4.02	4.61	2.1	2.81	3.52	4.3
2	set-23		2.77	3.83	4.73	2.46	2.81	4.02	4.69		2.77	3.63	4.61
3	set-23		2.81	4.1	4.73		2.89	4.06	4.69	2.18	2.77	3.55	
1	set-23		2.85	4.02	4.68		2.85	4.02	4.61		2.77	3.52	4.3
2	set-23		2.81	4.1	4.73	2.46	2.81	4.02	4.69		2.77	3.59	4.61
3	set-23		2.77	3.83	4.69		2.85	4.06	4.69	2.23	2.77	3.55	
1	set-23		2.85	4.02	4.38		2.85	4.02	4.61		2.77	3.59	4.61
2	set-23		2.81	4.1	4.73		2.89	4.06	4.69	2.1	2.77	3.52	4.3
3	set-23		2.77	3.83	4.69			4.69		2.1	2.77	3.79	4.26
1	ott-23		2.89	4.02	4.77	2.46	2.89	4.06	4.77	2.07	2.81	3.71	4.26

Monitoring activity on Fiorenza Node of A4 Highway

2	ott-23		2.85	3.79	4.73		2.85	3.95	4.69			3.83	
3	ott-23			4.02	4.73			4.02	4.73		2.81	3.83	4.53
1	ott-23		2.89	4.06	4.77	2.46	2.89	4.06	4.73			3.83	4.53
2	ott-23		2.85	3.71	4.77		2.85	3.98	4.69	2.07	2.81	3.71	4.26
3	ott-23			3.79	4.77			4.02	4.69		2.89	3.52	4.3
1	ott-23			4.02	4.73	2.46	2.89	4.06	4.77			3.83	4.53
2	ott-23		2.89	4.02	4.77	2.46	2.85	4.06			2.81	3.83	
3	ott-23			3.98	4.73	2.46	2.85	4.06	4.73		3.08	3.63	
1	nov-23		2.89		4.3	2.5	2.89	4.1			2.77	3.63	4.26
2	nov-23				4.77			4.14	4.77		2.81	3.98	4.34
3	nov-23	2.5	2.89		4.53			4.06	4.73	2.5	2.85	3.59	
1	nov-23		2.89	3.75	4.3	2.5	2.89	4.1	4.65		2.77	3.63	4.26
2	nov-23				4.77			4.1	4.77		2.81	3.98	4.38
3	nov-23	2.53	2.89	3.83	4.53	2.5	2.93	4.1		2.07	2.81		4.45
1	nov-23				4.77			4.14	4.77		2.77	3.63	4.26
2	nov-23	2.5	2.89		4.53	2.5	2.93	4.06		2.07	2.81		4.45
3	nov-23			4.1	4.53	2.5	2.89	4.1			2.85		4.34
1	dic-23		2.93	3.87	4.8	2.5	2.93	4.1	4.8	2.34	2.85	3.87	4.26
2	dic-23	2.5	2.93	4.06	4.8		2.97	3.98	4.8		2.81	3.98	4.65
3	dic-23		2.89	4.06	4.77	2.5	2.93	4.1	4.77		2.81	3.71	4.26
1	dic-23		2.97	3.91	4.8	2.5	2.93	4.1	4.8	2.34	2.85	3.9	4.26
2	dic-23	2.5	2.93	4.1	4.8		2.97	3.98	4.8		2.81	3.98	4.65
3	dic-23		2.89	4.02	4.77	2.46	2.93	4.1	4.77		2.81	3.71	4.26
1	dic-23		2.97	3.91	4.8	2.5	2.93	4.14	4.8		2.85	3.71	4.29
2	dic-23		2.89	3.98	4.77	2.5	2.93	4.1	4.73	2.1	2.85		4.71
3	dic-23		2.85	4.1	4.69		2.97	3.95	4.8		2.81	3.98	4.65

5.4.1 Vertical direction (x)

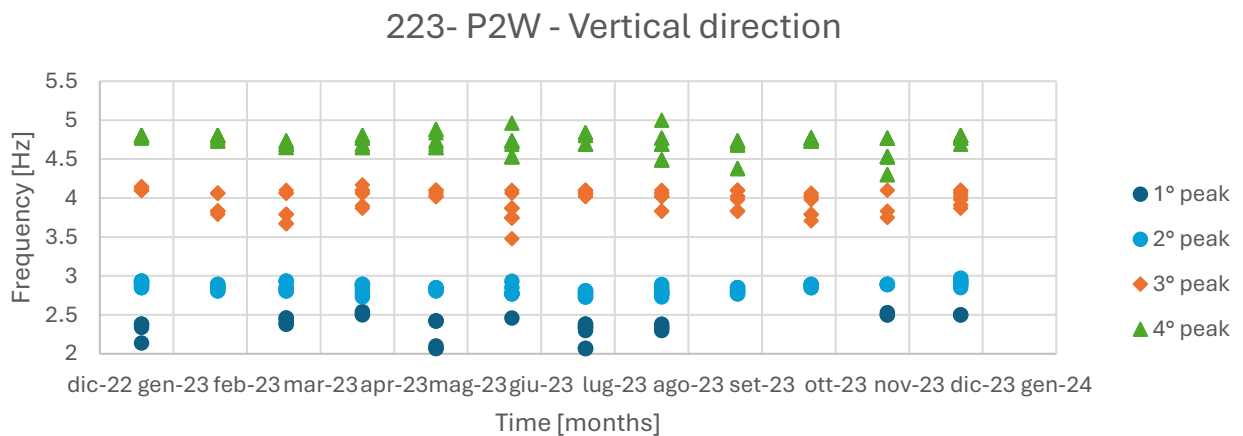

Figure 5-12: 223 – P2W - Natural frequencies obtained in vertical direction

5.4.2 Longitudinal direction (y)

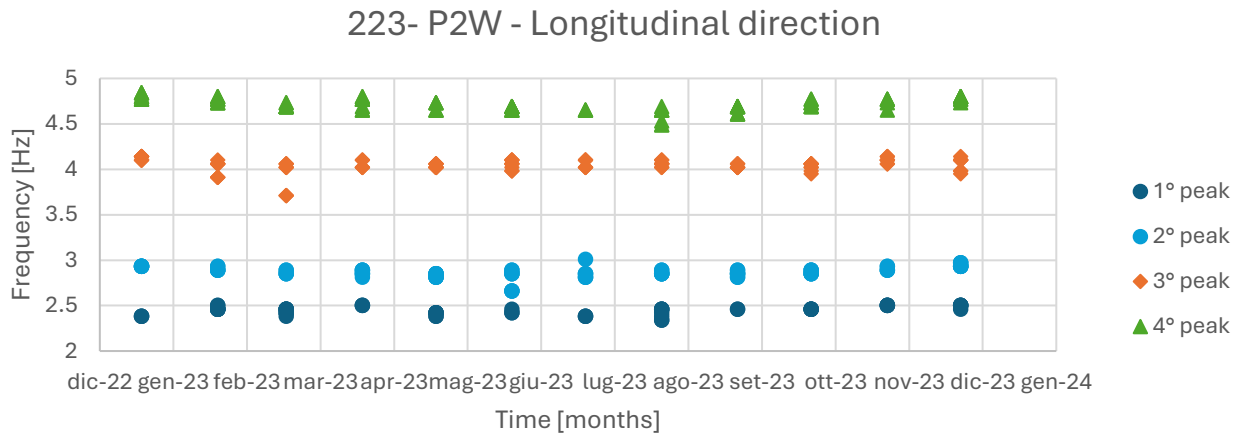

Figure 5-13: 223 – P2W - Natural frequencies obtained in longitudinal direction

5.4.3 Transverse direction (z)

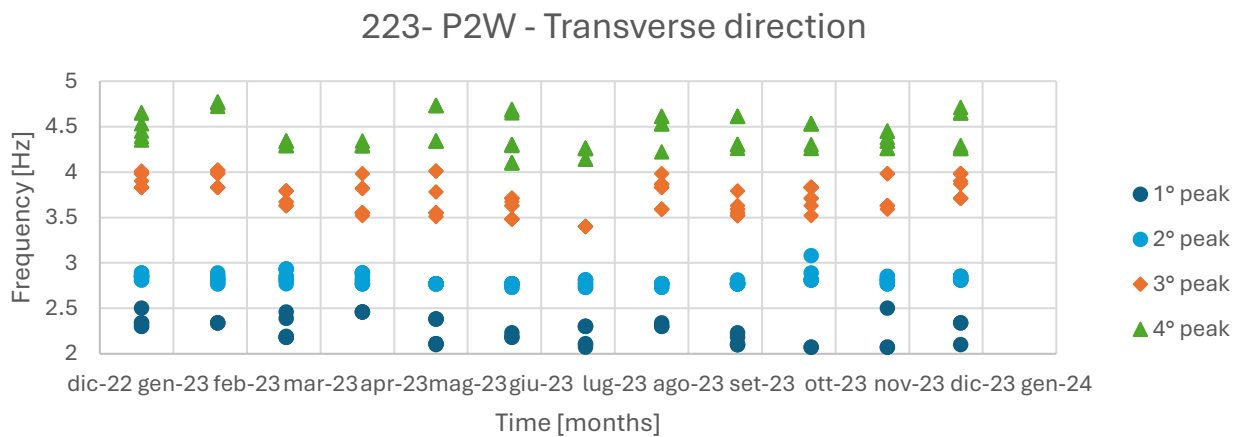

Figure 5-14: 223 - P2W - Natural frequencies obtained in transverse direction

5.5 223 SP2 East pier Sensor 319E3

All the obtained frequencies have been now classified and represented in such a way to obtain the variation of the values during the year. So, the peaks value has been separated and the representation for the vertical, longitudinal and transverse direction have been obtained.

Table 5-6 2023 natural frequencies [Hz] identified for sensor 319E3 – 223 SP2 East pier

	Vertical direction				Longitudinal direction				Transverse direction			
	1° peak	2° peak	3° peak	4° peak	1° peak	2° peak	3° peak	4° peak	1° peak	2° peak	3° peak	4° peak
Numerosity	38	92	94	93	97	85	100	103	69	102	88	94
MEAN	2.23	2.80	3.90	4.64	2.46	2.89	4.03	4.72	2.16	2.82	3.68	4.40
SD	0.12	0.07	0.24	0.16	0.03	0.04	0.09	0.08	0.10	0.08	0.13	0.18
C.o.V.	5.4%	2.5%	6.0%	3.4%	1.2%	1.5%	2.3%	1.7%	4.8%	2.8%	3.7%	4.2%
Rating	28%	84%	67%	79%	98%	84%	93%	100%	53%	91%	73%	76%

Monitoring activity on Fiorenza Node of A4 Highway

1	gen-23		4.1	4.65	2.5	2.97	4.14	4.8		2.85	3.71	4.38	
2	gen-23	2.81	4.21	4.77	2.46	2.97	4.1	4.84	2.1	2.81	3.83		
3	gen-23	2.15	4.1		2.5		4.1	4.84		2.85	4.02		
1	gen-23		4.1	4.65	2.46	2.93	4.14	4.8		2.81	3.67	4.38	
2	gen-23	2.14	4.1		2.46	2.93	4.1	4.8		2.85		4.38	
3	gen-23	2.81		4.73	2.5		4.06	4.73	2.1	2.81	3.83	4.3	
1	gen-23		4.14	4.84	2.46	3.01	4.14	4.8		2.81	3.67	4.34	
2	gen-23		4.1	4.65	2.48		4.14	4.84	2.07	2.81	3.83	4.34	
3	gen-23	2.19	4.1		2.46	3.01	4.14	4.84		2.85	3.83		
1	feb-23		2.54	3.83	4.73	2.5	2.85	4.1	4.8	1.91	3.12	3.79	4.53
2	feb-23		2.81	3.98	4.77	2.5	2.89	4.06	4.77		2.81	3.79	4.73
3	feb-23		2.81	4.06	4.8	2.5	2.97	4.02	4.73	2.27	2.77	3.83	4.73
1	feb-23		2.81	4.06	4.8	2.5	2.89	4.06	4.8		3.12	3.79	4.53
2	feb-23		2.54	3.83	4.73	2.46	2.89	4.06	4.77	2.03	2.81	3.79	4.49
3	feb-23		2.81	4.06	4.77	2.5	2.96	4.02	4.73	2.26	2.81	3.83	4.77
1	feb-23		2.54	3.83	4.77	2.5	2.89	4.06	4.73	2.34	2.81	3.83	4.73
2	feb-23		2.81	4.06	4.8	2.5	2.97	3.98	4.73		2.81	4.01	4.77
3	feb-23		2.81	4.06	4.8	2.5	2.89	4.06	4.77		2.81	3.79	
1	mar-23		2.81	3.91	4.65	2.46	2.85	4.06	4.65	2.19	2.89	3.79	
2	mar-23		2.81	4.15		2.5		4.06	4.73	2.19	2.81	3.55	4.26
3	mar-23		2.81	4.06		2.46	2.89	4.1	4.73		2.81	3.78	4.38
1	mar-23		2.81	3.91	4.65	2.46	2.85	4.06	4.65	2.19	2.89	3.79	
2	mar-23		2.81	4.15		2.46		4.06	4.73	2.15	2.85	3.55	4.26
3	mar-23		2.81	4.06		2.42	2.89	4.1	4.73		2.81		4.3
1	mar-23		2.81	4.15		2.46	2.85	4.06	4.65	2.18	2.89	3.79	4.22
2	mar-23		2.81	3.91	4.65	2.46		4.02	4.73	2.15	2.81	3.55	4.26
3	mar-23			4.1	4.61	2.46	2.89	4.1	4.73		2.81		4.3
1	apr-23		2.93	4.33	4.77	2.46	2.93	4.06	4.8	1.95	2.89	3.71	4.22
2	apr-23	2.23	2.69	3.94	4.65		2.89	4.06	4.65		2.77	3.59	4.22
3	apr-23		2.77	4.22		2.42		3.9	4.61	2.14	2.93	3.63	4.57
1	apr-23		2.89	4.33	4.77	2.46	2.93	4.02	4.8	1.95	2.89	3.71	
2	apr-23	2.23	2.73	3.91	4.65	2.42	2.89	4.02	4.65		2.77	3.59	4.22
3	apr-23		2.77	4.22		2.42		3.91	4.65	2.14	2.93	3.63	4.57
1	apr-23		2.77	4.21		2.46	2.93	4.02	4.8	1.95	2.89	3.71	
2	apr-23		2.93	4.33	4.77	2.46	2.89	4.02	4.65		2.77	3.59	4.22
3	apr-23	2.23	2.73	3.91	4.65	2.46		4.02	4.69	2.15	2.93		4.61
1	mag-23	2.29	2.77	3.83	4.45	2.46	2.85	4.02	4.77	2.18	2.73	3.79	4.65
2	mag-23	2.1	2.77		4.65	2.42	2.85		4.73	2.1	2.77	3.55	4.65
3	mag-23		2.77	3.6		2.5		4.06	4.65	2.3	2.77	3.48	4.77
1	mag-23	2.29	2.77	4.14	4.49	2.46	2.89	4.02	4.77	2.15	2.73	3.79	4.49
2	mag-23	2.1	2.77	4.21	4.65	2.46	2.85		4.65	2.1	2.77		4.61
3	mag-23		2.81	3.95	4.73	2.5		4.06	4.73		2.77	3.71	
1	mag-23	2.29	2.77	3.82	4.49	2.46	2.89	4.02	4.77	2.07	2.77		4.18
2	mag-23	2.1	2.77		4.65	2.46	2.85		4.65	2.23	2.73		4.18
3	mag-23		2.81	3.95	4.73	2.5		4.06	4.73	2.23	2.81		4.34
1	giu-23		2.73	4.1	4.49	2.42	2.85	3.87	4.65	2.07	2.77	3.52	4.09
2	giu-23	2.29	2.81		4.77	2.46		4.06	4.84	2.26	2.77	3.63	
3	giu-23		3.91	4.73		2.46	2.89	4.06	4.61			3.71	4.73

Monitoring activity on Fiorenza Node of A4 Highway

1	giu-23		2.73	4.1	4.49	2.42	2.85	3.87	4.65	2.07	2.77	3.52	4.09
2	giu-23		2.81		4.77	2.46		4.06	4.84	2.23	2.77	3.55	
3	giu-23		2.77	3.71	4.73	2.46	2.85	4.06	4.61			3.71	4.73
1	giu-23		2.73	4.1	4.49	2.46		4.06	4.8	2.1	2.77	3.52	4.09
2	giu-23		2.77		4.73	2.42	2.85	3.87				3.71	4.73
3	giu-23	2.29	2.77	3.91	4.45	2.46	2.89	4.06	4.69	2.26	2.77	3.63	
1	lug-23	2.1	2.77	3.98	4.69	2.38	2.85	4.02	4.69	2.07	2.77	3.67	4.38
2	lug-23	2.3	2.77	4.14		2.38	2.81	3.79	4.77	2.3	2.77		4.14
3	lug-23	2.38	2.85	4.18	4.88	2.42	2.81	4.06	4.84		2.73	3.67	4.26
1	lug-23	2.1	2.77	3.98	4.69	2.38	2.89	4.02	4.69	2.07	2.77	3.71	4.38
2	lug-23	2.3	2.77	4.14	4.84	2.38	2.85	3.79	4.77	2.3	2.77		4.14
3	lug-23	2.38	2.85	4.14	4.86	2.42	2.85	4.06	4.84	2.34	2.7	3.67	4.26
1	lug-23	2.3	2.77	4.14	4.84	2.42		4.14		2.3	2.77	3.36	4.34
2	lug-23		2.77	3.98	4.69	2.38	2.85	4.02	4.69	2.07	2.77		4.14
3	lug-23		2.73	4.14		2.42	2.85	4.06	4.84	2.07	2.73		4.34
1	ago-23	2.29	2.77	4.02	4.69	2.42	2.89	4.06	4.45		3.08		4.84
2	ago-23	2.34	2.77	3.55	4.53	2.46	2.89	4.02	4.65	2.3	2.73	3.55	4.53
3	ago-23	2.34		3.83	5	2.46	2.89	4.02	4.69		2.81	3.55	4.69
1	ago-23	2.34	2.77	3.55	4.53	2.42	2.89	4.06	4.49		3.08		
2	ago-23	2.3			4.34	2.46	2.89	4.02	4.65	2.3	2.73	3.55	4.53
3	ago-23	2.29	2.77	3.83	4.69	2.5	2.89	4.02	4.73	2.3	2.92	3.59	4.38
1	ago-23	2.3	2.81	3.55	4.53	2.46	2.85	4.06	4.45	2.34	2.73	3.55	4.53
2	ago-23		2.81	3.6	4.65		2.89	3.91	4.73		2.81	3.55	4.69
3	ago-23		2.81	3.55		2.46		4.06	4.57	2.34	2.93	3.55	4.38
1	set-23		2.77	3.48	4.34		2.85	4.02	4.61		2.77	3.52	4.29
2	set-23		2.77	3.59	4.73	2.46	2.85	4.14	4.65	2.23	2.81	3.55	4.29
3	set-23		2.77		4.65		2.81	4.06	4.69		2.77	3.59	4.38
1	set-23		2.77	3.43	4.34		2.85	4.02	4.65		2.77	3.52	4.29
2	set-23		2.73	3.59	4.72		2.81	4.14	4.65	2.23	2.81	3.55	4.29
3	set-23		2.73		4.65	2.46	2.85	4.06	4.65	2.07	2.77	3.59	4.38
1	set-23		2.77		4.34		2.85	4.14	4.65		2.77	3.59	4.3
2	set-23		2.77	3.59	4.73			4.06	4.73		2.77	3.48	4.3
3	set-23		2.89	3.59	4.41		2.85	4.02	4.61	2.11	2.77	3.59	
1	ott-23	2.1	2.81	3.55	4.53	2.46	2.93		4.73	2.18	2.93	3.55	4.26
2	ott-23		2.85	3.55	4.26	2.46	2.93	4.02	4.73	2.15	2.81	3.71	4.26
3	ott-23			3.83	4.53	2.46	2.89	3.98	4.69	2.34	2.85	3.79	4.45
1	ott-23	2.38	2.85	3.59	4.3	2.46	2.93		4.77	2.18	2.93	3.55	4.26
2	ott-23	2.1	2.81	3.59	4.53	2.46	2.89	3.98	4.69	2.14	2.81	3.71	4.26
3	ott-23			3.83	4.53	2.46	2.93	4.02	4.73	2.14	2.93	3.55	4.29
1	ott-23			3.83	4.53	2.46	2.93	4.02	4.73			3.83	4.53
2	ott-23		2.85	3.55	4.36	2.46		4.06	4.73	2.19	2.93	3.55	4.3
3	ott-23	2.29	2.89		4.45	2.42		4.02	4.69	2.19	2.93	3.71	4.26
1	nov-23	1.95	2.77	3.55	4.34	2.46	2.89	3.83			2.77	3.59	4.25
2	nov-23		2.81	3.59	4.45	2.46	2.89	3.63	4.77	2.07	2.81	3.59	4.34
3	nov-23		2.81		4.57	2.46	2.89		4.69			3.75	4.22
1	nov-23	1.95	2.77	3.55	4.34	2.46	2.89	3.87			2.77	3.59	4.25
2	nov-23		2.81	3.59	4.45	2.46	2.89	3.63	4.77				4.22
3	nov-23				4.57	2.46	2.89		4.69	2.07	2.81	3.59	4.34
1	nov-23		2.81	3.67	4.57	2.42		4.1	4.77		2.77	3.59	4.26

Monitoring activity on Fiorenza Node of A4 Highway

2	nov-23	1.95	2.77	3.55	4.34	2.46	2.89	4.06		1.99	2.81	4.49	
3	nov-23			3.69	4.53	2.46	2.89		4.65		2.85	3.75	4.26
1	dic-23	2.34	2.89	3.83	4.8	2.5	2.93	4.1	4.84	2.34	2.89	3.83	4.41
2	dic-23		2.89	3.83	4.77	2.46	2.93	4.1	4.84	2.15	2.85		4.53
3	dic-23		2.89	3.71	4.77			4.1	4.77	2.15	2.81	3.98	4.45
1	dic-23		2.89	3.82	4.77	2.5	2.93	4.06	4.8		2.85	3.75	4.45
2	dic-23	2.29	2.89		4.84	2.46	2.93	4.06	4.8	2.15	2.85		4.53
3	dic-23		2.93	3.82	4.77			4.1	4.77	2.15	2.85		4.49
1	dic-23	2.34	2.89	3.83	4.8	2.46	2.93	4.1	4.77	2.15	2.85	4.02	4.49
2	dic-23		2.93	3.83	4.77	2.5	2.93	4.1	4.8		2.81	3.98	4.45
3	dic-23		2.89	3.71	4.77	2.46	2.93	4.1	4.77	2.15	2.85		4.53

5.5.1 Vertical direction (x)

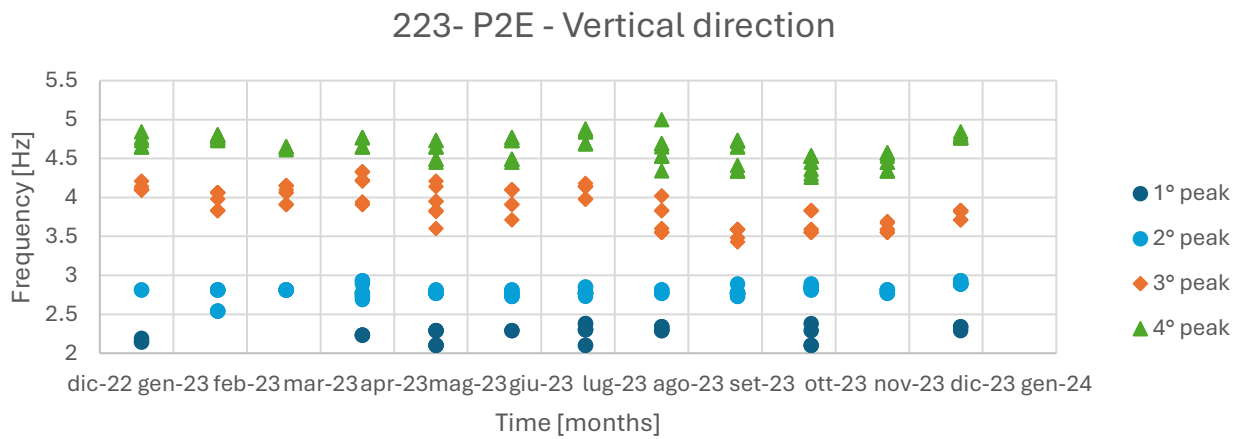

Figure 5-15: 223- P2E - Natural frequencies obtained in vertical direction

5.5.2 Longitudinal direction (y)

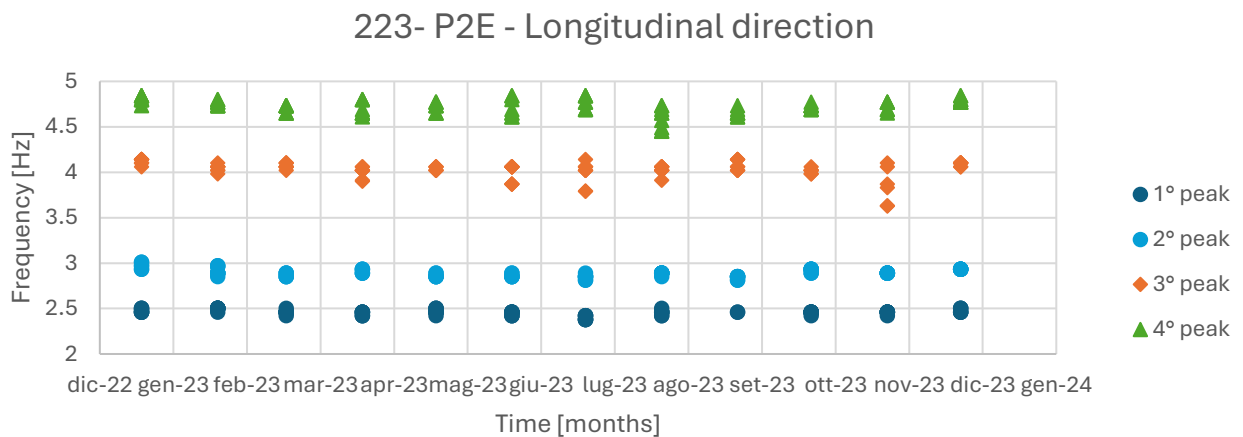

Figure 5-16: 223- P2E - Natural frequencies obtained in longitudinal direction

5.5.3 Transverse direction (z)

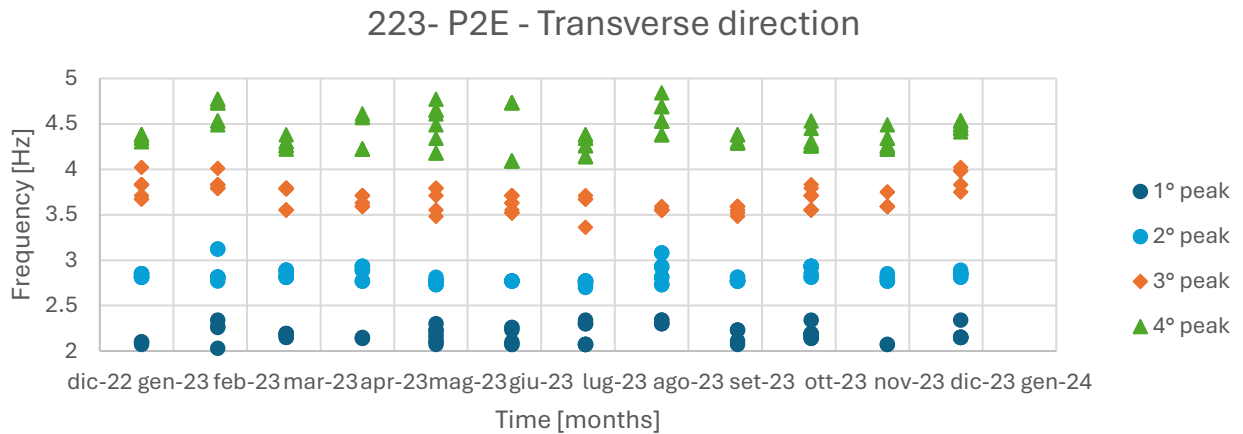

Figure 5-17: 223 - P2E - Natural frequencies obtained in transverse direction

For this pier an anomaly has been observed. Beside the frequencies shown in Table 5-6, that are regular and belong to the standard behavior of these decks, lower frequencies are found only for this sensor. These lower frequencies are found in vertical and transverse directions and are presented in Table 5-7.

Table 5-7: Frequency anomalies for sensor 319E3 – bridge 223 – Sp2 – P2E

	Frequency anomalies		
	Vertical	Transverse	
Numerosity	22	53	57
MEAN	0.56	0.27	0.95
SD	0.38	0.24	0.27
C.o.V.	67.0%	91.4%	28.3%
Rating	3%	6%	17%

1	gen-23	0.47	0.48	1.4
2	gen-23		0.43	1.13
3	gen-23		0.31	
1	gen-23	0.47	0.47	1.44
2	gen-23		0.42	
3	gen-23		0.47	1.13
1	gen-23		0.47	1.33
2	gen-23	0.47	0.43	1.17
3	gen-23			
1	feb-23		0.04	0.59
2	feb-23		0.04	0.86
3	feb-23	0.78		
1	feb-23	0.78		0.59
2	feb-23		0.04	0.86
3	feb-23		0.23	0.93
1	feb-23			
2	feb-23			

Monitoring activity on Fiorenza Node of A4 Highway

3	feb-23	0.78	0.04	0.86
1	mar-23			
2	mar-23			0.82
3	mar-23			0.51
1	mar-23			
2	mar-23			0.85
3	mar-23			0.39
1	mar-23			
2	mar-23			0.85
3	mar-23		0.39	1.29
1	apr-23		0.39	1.13
2	apr-23		0.63	
3	apr-23		0.7	1.37
1	apr-23	0.39	0.39	1.09
2	apr-23	0.66		
3	apr-23		0.7	1.33
1	apr-23		0.39	1.09
2	apr-23			
3	apr-23		0.7	1.41
1	mag-23			
2	mag-23			0.78
3	mag-23		0.04	0.66
1	mag-23			
2	mag-23		0.04	0.66
3	mag-23		0.04	1.01
1	mag-23			0.7
2	mag-23			
3	mag-23		0.08	0.78
1	giu-23		0.31	0.98
2	giu-23	0.9		
3	giu-23			
1	giu-23		0.31	0.98
2	giu-23	0.86		
3	giu-23		0.31	0.98
1	giu-23			
2	giu-23			
3	giu-23			
1	lug-23		0.39	1.09
2	lug-23			
3	lug-23			0.86
1	lug-23			0.39
2	lug-23			
3	lug-23	0.04	0.04	0.86
1	lug-23		0.39	1.13
2	lug-23	0.04		
3	lug-23			
1	ago-23	1.05	0.04	1.02

Monitoring activity on Fiorenza Node of A4 Highway

2	ago-23			
3	ago-23	1.01		
1	ago-23		0.04	1.02
2	ago-23	1.05		
3	ago-23	1.05		
1	ago-23			
2	ago-23		0.31	
3	ago-23	0.47		
1	set-23			
2	set-23			
3	set-23			
1	set-23		0.66	
2	set-23		0.78	1.33
3	set-23			
1	set-23			
2	set-23			
3	set-23			
1	ott-23		0.04	0.74
2	ott-23		0.04	0.82
3	ott-23			
1	ott-23	0.04	0.04	0.74
2	ott-23	0.04	0.04	0.86
3	ott-23		0.04	0.59
1	ott-23			
2	ott-23		0.04	0.74
3	ott-23		0.04	0.86
1	nov-23			
2	nov-23			
3	nov-23		0.04	0.9
1	nov-23	0.98		0.98
2	nov-23		0.12	0.9
3	nov-23		0.12	0.94
1	nov-23			
2	nov-23			
3	nov-23			
1	dic-23			
2	dic-23		0.04	0.74
3	dic-23		0.04	
1	dic-23			
2	dic-23	0.04	0.74	1.4
3	dic-23	0.04	0.74	1.56
1	dic-23		0.04	0.74
2	dic-23		0.04	
3	dic-23		0.04	0.74

Monitoring activity on Fiorenza Node of A4 Highway

The anomaly frequencies may suggest the presence of a damage on the pier, being the frequencies lower than the natural ones of the sound element. Like can be seen from Figure 5-18 and Figure 5-19 there are present two cracks on the pile, under the elements which give the connection between the longitudinal beams and the pile.



Figure 5-18: P2E – Field photography



Figure 5-19: P2E – Field photography

6. Bridge 223 deck 6

The Bridge 223 counts 2 monitored decks: span 2 and span 6 (see Figure 6-1).

On the deck number 6, three sensors are present: one in the midspan ($L/2$), one at $L/4$ of the span, and one at $L/8$ of the span.

The sensors present on deck number 6 are:

- 2B5E7 – situated in the midspan;
- 2BCF9 – situated at a distance of $L/4$;
- 2BCAF – situated at a distance of $L/8$.

Monitored deck

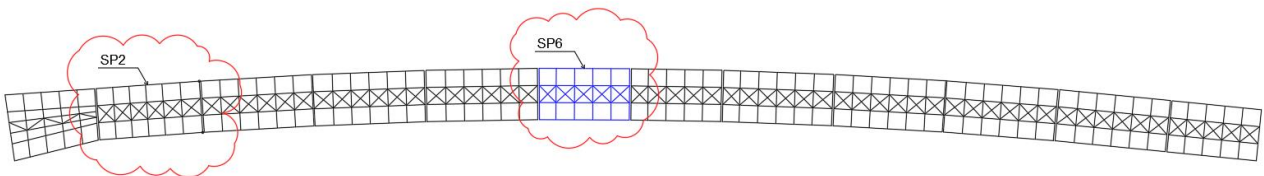
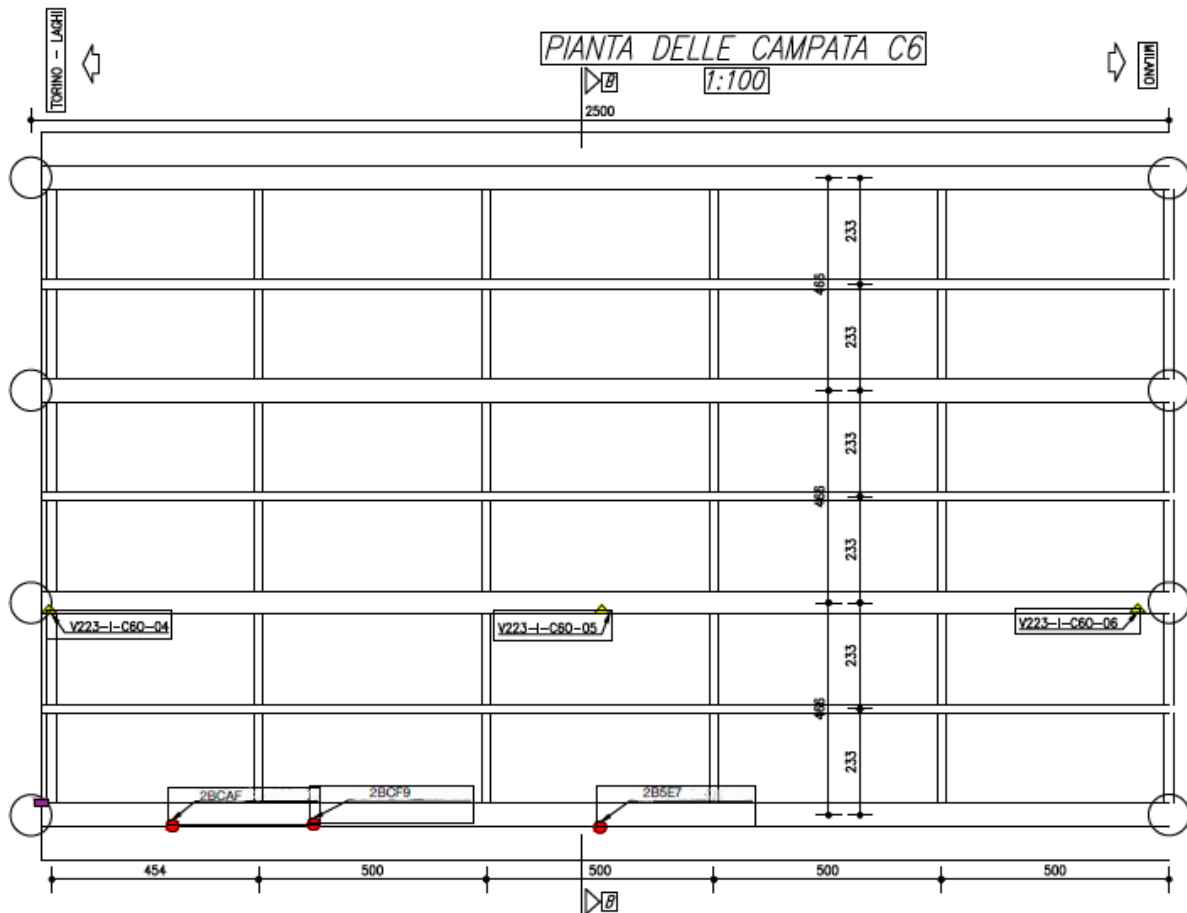

Figure 6-1: Deck 6 of 223 bridge



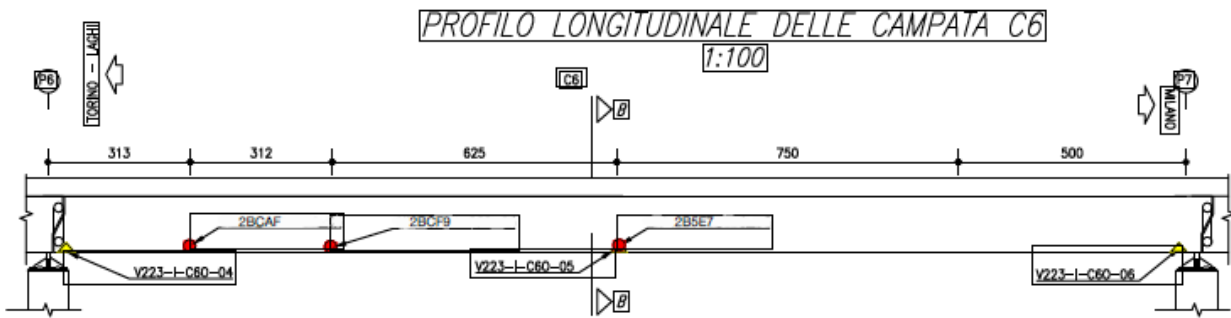

Figure 6-2: Sensor position on deck 6 of 223 bridge

All the accelerograms registered at scheduled times (every 6 hours) and long 102s have been analyzed and the results are represented in the following Annexes:

- Annex 14 – Sensor 2B5E7
- Annex 15 – Sensor 2BCF9
- Annex 16 – Sensor 2BCAF

The mean frequencies values identified for this deck are presented in the Table 6-1.

Table 6-1 2023 Average natural frequencies [Hz] identified for 223 deck 6

Direction	Frequency	L/2	L/4	L/8
Vertical	1 st			
	2 nd	2.89	2.93	2.96
	3 rd	3.71	3.71	3.71
	4 th	4.37	4.36	4.37
Longitudinal	1 st	2.30	2.32	2.32
	2 nd	2.90	2.90	2.89
	3 rd	3.67	3.64	3.66
	4 th	4.42	4.35	4.34
Transverse	1 st	2.00	2.06	2.08
	2 nd	2.80	2.84	2.86
	3 rd	3.72	3.74	3.78
	4 th	4.37	4.35	4.34

6.1 223 SP6 L/2 Sensor 2B5E7

All the obtained frequencies have been now classified and represented in such a way to obtain the variation of the values during the year. So, the peaks value has been separated and the representation for the vertical, longitudinal and transverse direction have been obtained.

Table 6-2 2023 natural frequencies [Hz] identified for sensor 2B5E7 – 223 SP6 L/2

	Vertical direction				Longitudinal direction				Transverse direction			
	1° peak	2° peak	3° peak	4° peak	1° peak	2° peak	3° peak	4° peak	1° peak	2° peak	3° peak	4° peak
Numerosity		14	105	104	108	73	96	64	25	41	30	94
MEAN		2.89	3.71	4.37	2.30	2.90	3.67	4.42	2.00	2.80	3.72	4.37

Monitoring activity on Fiorenza Node of A4 Highway

SD	0.13	0.04	0.05	0.08	0.06	0.16	0.21	0.12	0.06	0.03	0.05
C.o.V.	4.5%	1.0%	1.1%	3.6%	2.0%	4.5%	4.7%	6.1%	2.3%	0.9%	1.2%
Rating	10%	100%	98%	84%	64%	70%	46%	16%	35%	29%	88%
1 gen-23		3.78	4.45	2.11	2.93	3.91	4.65				4.41
2 gen-23		3.75		2.23	3.01	3.87	4.69				4.45
3 gen-23		3.75	4.45	2.15	2.97	3.87					4.49
1 gen-23		3.71	4.45	2.15		3.9					4.45
2 gen-23		3.75	4.45	2.38	3.04	3.71	4.72			3.75	
3 gen-23		3.79		2.37	2.93	3.91				3.75	
1 gen-23		3.79	4.45	2.11	2.97	3.91	4.69				4.45
2 gen-23		3.75	4.41	2.23	2.97	3.87	4.65				4.45
3 gen-23		3.75	4.45	2.15		3.91					
1 feb-23		3.75	4.38	2.34		3.87	4.34				4.38
2 feb-23		3.75	4.38	2.34		3.98	4.38	2.22	2.89	3.78	4.38
3 feb-23		3.75	4.38	2.11	2.93	3.75				3.74	4.38
1 feb-23		3.75	4.41	2.1	2.92	3.75					
2 feb-23		3.75	4.41	2.34		3.87	4.3			3.75	
3 feb-23		3.75	4.41	2.38		3.98	4.38			3.75	
1 feb-23		3.75	4.41	2.34		3.83	4.3				4.41
2 feb-23		3.75	4.41	2.38		3.98	4.38				4.41
3 feb-23		3.75	4.41	2.11	2.89	3.75		2.23	2.93	3.79	4.38
1 mar-23	2.73	3.71	4.34	2.34	2.89	3.71	4.21	2.14	2.81		4.3
2 mar-23		3.71	4.34	2.34	3.01	3.55	4.3		2.77		4.38
3 mar-23		3.71	4.3	2.11	2.89	3.52					4.34
1 mar-23	2.73	3.71	4.34	2.34	2.89	3.71	4.22	2.14	2.81		4.3
2 mar-23		3.71	4.34	2.34	3.01	3.55	4.3				4.38
3 mar-23		3.71	4.34	2.11	2.89	3.52					4.34
1 mar-23	2.81	3.67	4.34	2.34	2.89	3.75	4.22	2.11	2.81		4.3
2 mar-23		3.75	4.41	2.34	3.01	3.55	4.3				4.38
3 mar-23	2.77	3.71	4.34	2.3	2.93	3.59			2.81	3.75	4.38
1 apr-23		3.71	4.38	2.34		3.63	4.26		2.93		4.38
2 apr-23		3.67	4.3	2.34	2.93	3.59	4.34				
3 apr-23		3.71	4.34	2.42	3.01	3.83			2.85		4.38
1 apr-23		3.71	4.38	2.34		3.63	4.26		2.92		4.38
2 apr-23		3.71	4.34	2.3	2.93	3.59	4.34				
3 apr-23		3.67	4.34	2.34		3.59					4.34
1 apr-23		3.71	4.38	2.34		3.63	4.26				4.34
2 apr-23		3.71	4.26	2.3	2.93	3.59	4.34				
3 apr-23		3.71	4.34	2.42	2.96	3.83					4.34
1 mag-23	2.93	3.71	4.34	2.23	2.81	3.52	4.38		2.73		4.34
2 mag-23	2.81	3.67	4.34	2.3	2.81	3.59	4.19	1.91	2.77		4.34
3 mag-23		3.6	4.3	2.34	2.85	3.52			2.77		4.34
1 mag-23	2.93	3.71	4.34	2.23	2.81	3.51	4.34	1.95	2.73		4.34
2 mag-23	2.77	3.67	4.34	2.3	2.81	3.59	4.19	1.95	2.77		4.34
3 mag-23		3.67	4.3	2.34	2.85	3.52			2.73		4.3
1 mag-23	2.81	3.67	4.34	2.23	2.81	3.52	4.38	1.91	2.73		4.34
2 mag-23	2.93	3.67	4.34	2.3	2.85	3.59	4.19	1.91	2.77		4.34
3 mag-23		3.71	4.38	2.34	2.85	3.55					

Monitoring activity on Fiorenza Node of A4 Highway

1	giu-23		3.67	4.34	2.34				2.73		4.3	
2	giu-23		3.71	4.3	2.34	2.85	3.51		2.73		4.3	
3	giu-23		3.71	4.38	2.38		3.71				4.3	
1	giu-23		3.67	4.34	2.34				2.73	3.67	4.3	
2	giu-23		3.71	4.34	2.34	2.85	3.51				4.3	
3	giu-23		3.71	4.38	2.38	2.97	3.71		2.73	3.67	4.38	
1	giu-23		3.63	4.3	2.34		3.4				4.3	
2	giu-23		3.71	4.3	2.38	2.85	3.55		2.73	3.71	4.3	
3	giu-23		3.71	4.38	2.27		3.79		2.85		4.38	
1	lug-23		3.67	4.3	2.34		4.22	1.91	2.77		4.3	
2	lug-23		3.71	4.26	2.34	2.85	3.52	4.18	2.77		4.25	
3	lug-23		3.67	4.34	2.38			4.84	1.95	3.71	4.34	
1	lug-23		3.71	4.3	2.34		3.52	4.22	2.77		4.3	
2	lug-23		3.71	4.25	2.34	2.85		4.19	1.89	2.81	4.28	
3	lug-23		3.71	4.34	2.38			4.84	1.95	3.67	4.3	
1	lug-23		3.71	4.3	2.34			4.22	1.95	3.67	4.34	
2	lug-23		3.71	4.26	2.34	2.81	3.48	4.34	1.88		4.3	
3	lug-23		3.71	4.34	2.38			4.84	1.95	2.77	4.3	
1	ago-23		3.67	4.34	2.34	2.85	3.55	4.49			4.3	
2	ago-23		3.75		2.34	2.89	3.59		2.77		4.34	
3	ago-23		3.71	4.34	2.34		3.55		2.24		4.3	
1	ago-23		3.67	4.34	2.34	2.85	3.55	4.49			4.3	
2	ago-23		3.75	4.34	2.34	2.85	3.59					
3	ago-23		3.71	4.34	2.34		3.55		1.88	2.77	4.38	
1	ago-23		3.71	4.34	2.34	2.85	3.55	4.49	2.24	3.67	4.3	
2	ago-23		3.67	4.34	2.34		3.55					
3	ago-23				2.34		3.55	4.22			4.3	
1	set-23		3.63	4.34	2.34	2.89	3.48	4.22		3.71	4.34	
2	set-23		3.63	4.38	2.34	2.81	3.48	4.22		3.71	4.3	
3	set-23	3.09		4.38	2.34	2.93	3.59			3.71	4.41	
1	set-23	3.06	3.64	4.34	2.34	2.89	3.48	4.22		3.71		
2	set-23		3.64	4.38	2.34	2.81	3.48			3.71	4.3	
3	set-23	3.09		4.38	2.34	2.93	3.59			3.71	4.41	
1	set-23		3.67	4.38	2.34	2.89	3.48	4.22		3.67	4.38	
2	set-23	3.03	3.63	4.33	2.38	2.93	3.59				4.38	
3	set-23		3.67	4.34	2.38	2.81	3.51	4.26		3.67	4.34	
1	ott-23		3.75	4.41	2.34	2.89	3.55		2.85		4.41	
2	ott-23		3.75	4.34	2.15		3.55				4.38	
3	ott-23		3.75	4.41	2.3	2.85	3.55	4.34			4.34	
1	ott-23		3.75	4.41	2.34	2.89	3.55		2.85		4.41	
2	ott-23		3.75	4.34	2.15		3.55	4.43	2.77	3.71	4.34	
3	ott-23		3.75	4.41	2.3	2.85	3.59	4.39			4.38	
1	ott-23		3.75	4.41	2.34	2.93	3.83	4.49			4.41	
2	ott-23		3.75	4.34	2.15		3.83		2.85		4.41	
3	ott-23		3.83	4.41	2.34	2.89	3.55				4.38	
1	nov-23		3.67	4.41	2.34	2.93	3.63	4.39	1.91	2.89	3.71	4.41
2	nov-23		3.71	4.41	2.19	2.93			1.95		4.41	
3	nov-23		3.71	4.41	2.38		3.98	4.73			4.41	
1	nov-23		3.71	4.41	2.19	2.93		4.39	1.91	2.89	3.71	4.41

Monitoring activity on Fiorenza Node of A4 Highway

2	nov-23		3.71	4.41	2.34	2.93	3.63	4.39			3.75	4.41
3	nov-23		3.71	4.41	2.38		4.01	4.73				4.45
1	nov-23		3.71	4.41	2.18	2.93			1.95	2.81		4.38
2	nov-23		3.75	4.41	2.38		4.01	4.73				4.41
3	nov-23		3.71	4.41	2.34	2.93	3.63	4.38				4.41
1	dic-23		3.71	4.41	2.38	2.93	3.63	4.84				4.45
2	dic-23		3.75	4.38	2.19	2.93	4.01				3.71	4.45
3	dic-23		3.75	4.41	2.38		3.63	4.77	2.03	2.89		4.45
1	dic-23		3.71	4.41	2.38	2.93	3.63	4.84				4.45
2	dic-23		3.75	4.38	2.19	2.93	4.01				3.71	4.45
3	dic-23		3.75	4.53	2.38		3.63	4.39		2.93		4.45
1	dic-23		3.75	4.38	2.38	2.93	3.63	4.84		2.81	3.75	4.41
2	dic-23		3.71	4.41	2.19	2.93	4.02					
3	dic-23		3.71	4.45	2.19	2.93		4.39				4.45

6.1.1 Vertical direction (x)

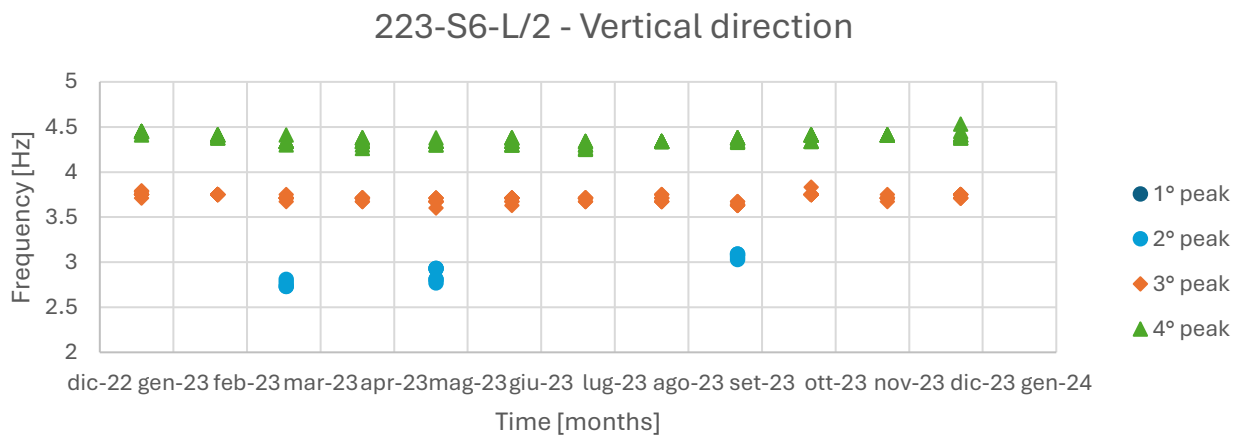

Figure 6-3: 223- S6 – L/2 - Natural frequencies obtained in vertical direction

6.1.2 Longitudinal direction (y)

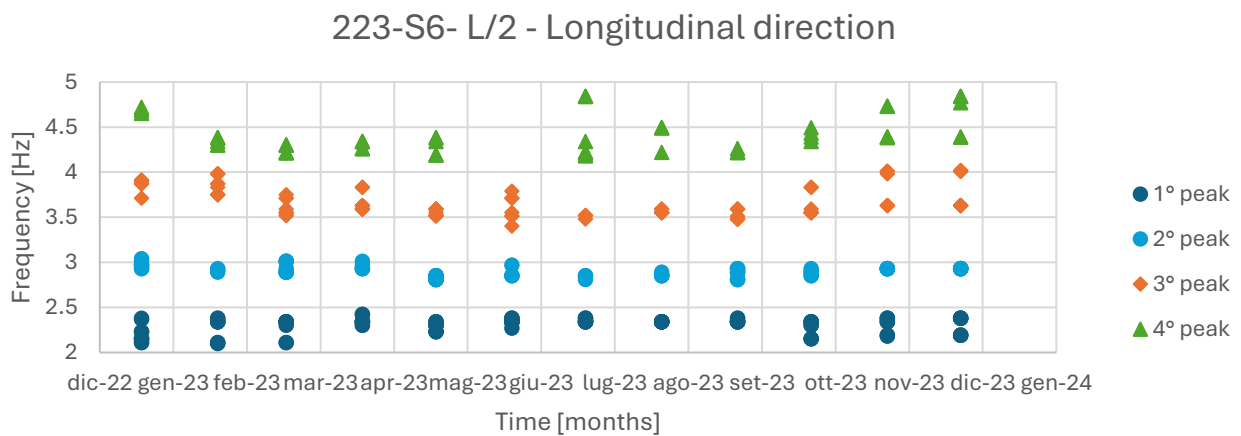

Figure 6-4: 223- S6 – L/2 - Natural frequencies obtained in longitudinal direction

6.1.3 Transverse direction (z)

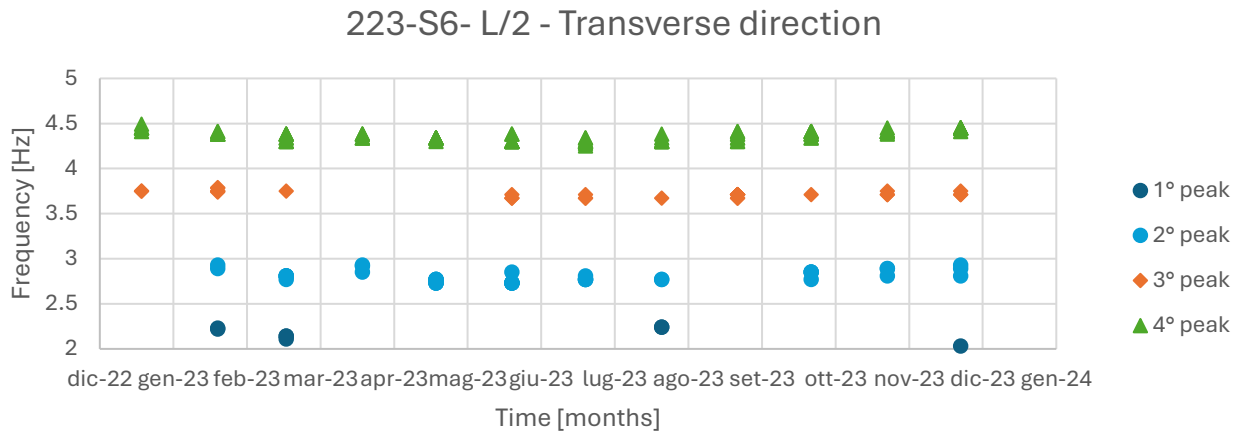

Figure 6-5: 223- S6 - L/2 - Natural frequencies obtained in transverse direction

6.2 223 SP6 L/4 Sensor 2BCF9

All the obtained frequencies have been now classified and represented in such a way to obtain the variation of the values during the year. So, the peaks value has been separated and the representation for the vertical, longitudinal and transverse direction have been obtained.

Table 6-3 2023 natural frequencies [Hz] identified for sensor 2BCF9 – 223 SP6 L/4

	Vertical direction				Longitudinal direction				Transverse direction			
	1° peak	2° peak	3° peak	4° peak	1° peak	2° peak	3° peak	4° peak	1° peak	2° peak	3° peak	4° peak
Numerosity	0	3	108	108	107	59	101	99	50	79	26	82
MEAN		2.93	3.71	4.36	2.32	2.90	3.64	4.35	2.06	2.84	3.74	4.35
SD		0.00	0.04	0.05	0.07	0.06	0.09	0.10	0.16	0.07	0.06	0.08
C.o.V.		0.0%	1.0%	1.0%	2.9%	1.9%	2.5%	2.3%	7.6%	2.4%	1.6%	1.9%
Rating		3%	100%	100%	84%	50%	82%	82%	29%	65%	23%	71%
1	gen-23		3.75	4.42	2.38	3.01	3.71	4.45				4.38
2	gen-23		3.71	4.45	2.34		3.75	4.34	2.85			4.45
3	gen-23		3.75	4.34	2.38		3.79	4.39	2.85			4.38
1	gen-23		3.75	4.41	2.38	3.01	3.71	4.49				4.38
2	gen-23		3.71	4.45	2.34		3.79	4.34	2.34	2.89		4.49
3	gen-23		3.75	4.41	2.34		3.75	4.38	2.11		3.75	4.38
1	gen-23		3.75	4.41	2.38	3.01	3.75	4.49				4.38
2	gen-23		3.71	4.45	2.34		3.79	4.34		2.81		4.49
3	gen-23		3.71	4.49	2.38		3.75	4.34		2.81		4.38
1	feb-23		3.75	4.42	2.38		3.75	4.34	2.19	2.97	3.79	4.38
2	feb-23		3.75	4.38	2.34		3.71	4.34				
3	feb-23		3.75	4.42	2.11	2.93	3.75	4.34			3.79	
1	feb-23		3.75	4.41	2.38		3.75	4.34	2.15	2.97	3.79	4.38
2	feb-23		3.75	4.41	2.34		3.67	4.34				
3	feb-23		3.75	4.41	2.11	2.93	3.75	4.34			3.71	

Monitoring activity on Fiorenza Node of A4 Highway

1	feb-23		3.75	4.41	2.38		3.67	4.34			3.75	
2	feb-23		3.71	4.41	2.11		3.75		2.07			
3	feb-23		3.75	4.38	2.34		3.71				3.75	4.41
1	mar-23		3.71	4.34	2.38	2.93	3.55	4.3	1.91	2.81	3.83	4.21
2	mar-23		3.75	4.38	2.38	2.89	3.71	4.26	1.95	2.89		
3	mar-23		3.71	4.34	2.11	2.93	3.78	4.3		3.01		4.3
1	mar-23		3.71	4.34	2.34	3.05	3.55	4.3	1.91	2.81	3.79	4.22
2	mar-23		3.75	4.41	2.34	2.89	3.71	4.26	1.99	2.89		
3	mar-23		3.75	4.34	2.11	2.89	3.49	4.26		3.01	3.68	4.3
1	mar-23		3.71	4.34	2.34	3.05	3.55	4.3	1.91	2.81	3.75	4.22
2	mar-23		3.75	4.38	2.34	2.89	3.71	4.3	1.99	2.89		
3	mar-23		3.71	4.34	2.3	2.89						4.38
1	apr-23		3.67	4.38	2.34		3.71	4.26	2.03	2.93		4.41
2	apr-23		3.67	4.3	2.3	2.93	3.59	4.41				4.34
3	apr-23		3.71	4.33	2.42	2.97	3.75			2.85		4.34
1	apr-23		3.67	4.38	2.34		3.67	4.26	2.03	2.93		4.38
2	apr-23		3.67	4.26	2.3	2.93	3.55	4.41				4.34
3	apr-23		3.71	4.34	2.3	2.89	3.67	4.34				
1	apr-23		3.71	4.38	2.34	3.01	3.71	4.26	1.99	2.93		4.41
2	apr-23		3.67	4.26	2.34	2.93	3.6	4.41				
3	apr-23		3.71	4.38	2.34					2.77		4.22
1	mag-23		3.67	4.34	2.3	2.85	3.52	4.38	2.11	2.77		4.18
2	mag-23	2.93	3.71	4.34	2.3	2.81	3.67	4.3	1.95	2.77		4.3
3	mag-23		3.55	4.3	2.34		3.55	4.3		2.73		4.26
1	mag-23		3.67	4.34	2.3	2.85	3.52	4.38	2.1	2.77		4.19
2	mag-23	2.93	3.71	4.34	2.3	2.81	3.67	4.3	1.99	2.77		4.3
3	mag-23		3.67	4.34	2.34		3.52	4.3		2.77		4.34
1	mag-23		3.67	4.34	2.3	2.81	3.52	4.38	2.11	2.77		4.18
2	mag-23	2.93	3.67	4.34	2.3	2.81	3.67	4.3	1.95	2.77		4.3
3	mag-23		3.67	4.38	2.34		3.55	4.3				
1	giu-23		3.71	4.38	2.34					2.81		4.26
2	giu-23		3.71	4.34	2.38	2.85	3.55	4.22	1.85	2.77		
3	giu-23		3.71	4.3	2.38		3.67	4.34		2.73		
1	giu-23		3.71	4.38	2.34					2.81		4.26
2	giu-23		3.71	4.3	2.34	2.85	3.55	4.26	1.85	2.77	3.67	4.3
3	giu-23		3.71	4.34	2.38		3.63	4.34		2.73		4.26
1	giu-23		3.71	4.3	2.34					2.81		4.26
2	giu-23		3.67	4.3	2.34	2.85	3.55	4.26	1.88	2.77		
3	giu-23		3.75	4.34	2.34		3.63	4.3				
1	lug-23		3.71	4.3	2.34		3.55	4.3	2.1	2.77		4.3
2	lug-23		3.71	4.3	2.34	2.85	3.55	4.19		2.77		4.22
3	lug-23		3.71	4.3	2.38		3.55	4.88				
1	lug-23		3.71	4.3	2.38			4.3		2.77		4.3
2	lug-23		3.71	4.3	2.34	2.85	3.55	4.19		2.77		4.22
3	lug-23		3.71	4.34	2.38		3.55	4.84				
1	lug-23		3.71	4.3	2.34			4.36	2.1	2.77		4.3
2	lug-23		3.71	4.3	2.34	2.85	3.55	4.18	2.1	2.77		4.22
3	lug-23		3.71	4.34	2.34	2.85	3.48	4.34				
1	ago-23		3.67	4.34	2.34	2.89	3.59	4.19	2.27	2.77		4.34

Monitoring activity on Fiorenza Node of A4 Highway

2	ago-23	3.75	4.34	2.34	2.85	3.59	4.41	2.34			4.26
3	ago-23	3.67	4.34	2.34		3.69	4.38	2.27	2.77	3.67	4.26
1	ago-23	3.75	4.34	2.34	2.89	3.59	4.19	2.34			4.26
2	ago-23	3.67	4.3	2.34	2.85	3.59	4.41	2.27	2.77		4.34
3	ago-23	3.67	4.34	2.34		3.69	4.38	2.27	2.77	3.67	4.26
1	ago-23	3.71	4.33	2.34	2.89	3.59	4.19	2.34	2.89	3.67	
2	ago-23	3.71	4.34	2.34	2.85	3.55	4.22				
3	ago-23	3.67	4.34	2.34		3.63		2.38			
1	set-23	3.67	4.34	2.3	2.89	3.48	4.34		2.77		4.38
2	set-23	3.63	4.34	2.34	2.93	3.55	4.34	1.91	2.89	3.71	4.34
3	set-23	3.67	4.3	2.3		3.55	4.34	1.88	2.85	3.71	4.34
1	set-23	3.63	4.34	2.34	2.89	3.48	4.34		2.77	3.89	4.45
2	set-23	3.63	4.34	2.34	2.93	3.55	4.34	1.91	2.96	3.59	4.38
3	set-23	3.63	4.34	2.34	2.85	3.59	4.34		2.81		4.3
1	set-23	3.67	4.38	2.3	2.89	3.48	4.34		2.77		4.45
2	set-23	3.67	4.38	2.34	2.93	3.55	4.38	2.3			
3	set-23	3.67	4.34	2.3		3.55	4.38	2.3			
1	ott-23	3.75	4.41	2.15	2.93	3.75	4.41		2.89		4.34
2	ott-23	3.75	4.34	2.34	2.85	3.55	4.3		2.85		4.41
3	ott-23	3.75	4.41	2.38		3.75	4.3		2.93		4.38
1	ott-23	3.75	4.41	2.15		3.75	4.41		2.89		4.34
2	ott-23	3.75	4.41	2.34	2.89	3.55	4.3		2.85		4.38
3	ott-23	3.75	4.34	2.3		3.59	4.38	1.91	2.85	3.75	4.41
1	ott-23	3.75	4.34	2.15	2.97	3.75	4.41		2.89		4.34
2	ott-23	3.75	4.41	2.34		3.75	4.34		2.93		4.38
3	ott-23	3.75	4.41	2.3		3.55	4.3		2.85		4.41
1	nov-23	3.75	4.41	2.34		3.67	4.3	2.03	2.85		4.45
2	nov-23	3.75	4.41	2.19	2.93	3.71	4.45	1.88	2.89		4.38
3	nov-23	3.75	4.41	2.34	2.93	3.63	4.34		2.81		4.38
1	nov-23	3.71	4.38	2.19	2.93	3.71	4.45	2.05	2.85		4.45
2	nov-23	3.71	4.41	2.34		3.67	4.34	1.88	2.89		4.38
3	nov-23	3.75	4.41	2.34	2.93	3.59	4.34		2.89		4.45
1	nov-23	3.75	4.41	2.19	2.93	3.71	4.45	2.03	2.85		4.49
2	nov-23	3.75	4.41	2.34		3.75	4.38	1.88	2.89		4.38
3	nov-23	3.75	4.41	2.34		3.63	4.34		2.85		4.49
1	dic-23	3.75	4.41	2.34		3.71	4.3		2.89	3.79	4.45
2	dic-23	3.75	4.41	2.38	2.93	3.75	4.45	2.03	2.89		4.49
3	dic-23	3.75	4.38	2.38		3.83	4.41		2.93	3.75	4.41
1	dic-23	3.75	4.41	2.38		3.71	4.3	2.07	2.93		4.45
2	dic-23	3.75	4.38	2.38	2.93	3.75	4.45		2.89	3.73	4.41
3	dic-23	3.75	4.45	2.19	2.93	3.75	4.38		2.89	3.71	4.41
1	dic-23	3.75	4.38			3.63	4.38	1.95	2.85	3.79	4.41
2	dic-23	3.75	4.41	2.38		3.71	4.3	1.95		3.79	
3	dic-23	3.75	4.41	2.38	2.93	3.75	4.45				

6.2.1 Vertical direction (x)

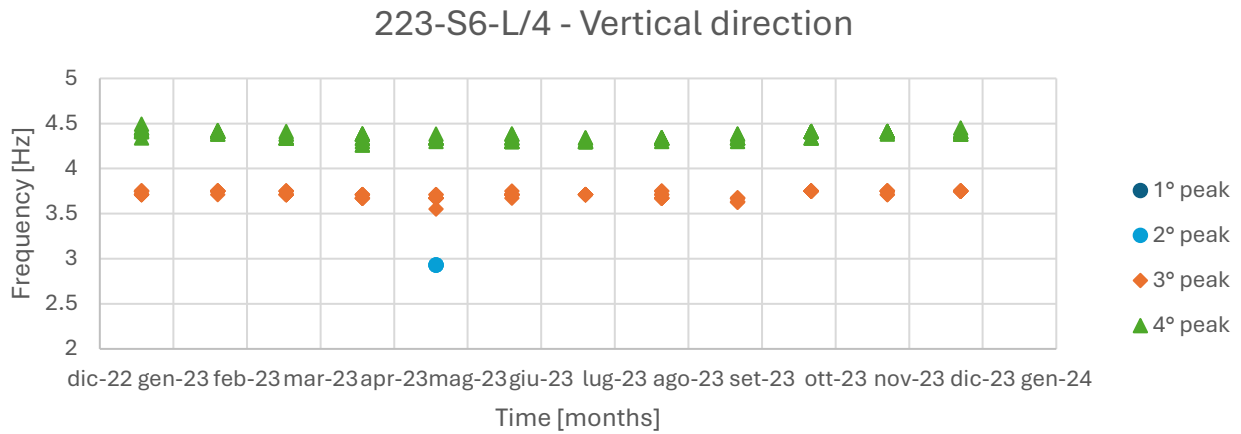

Figure 6-6: 223- S6 – L/4 - Natural frequencies obtained in vertical direction

6.2.2 Longitudinal direction (y)

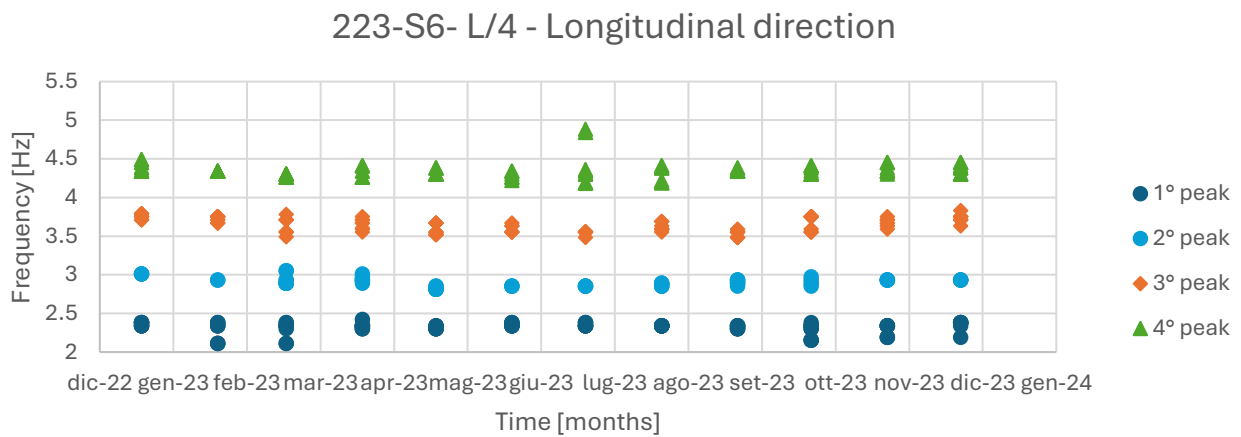

Figure 6-7: 223- S6 – L/4 - Natural frequencies obtained in longitudinal direction

6.2.3 Transverse direction (z)

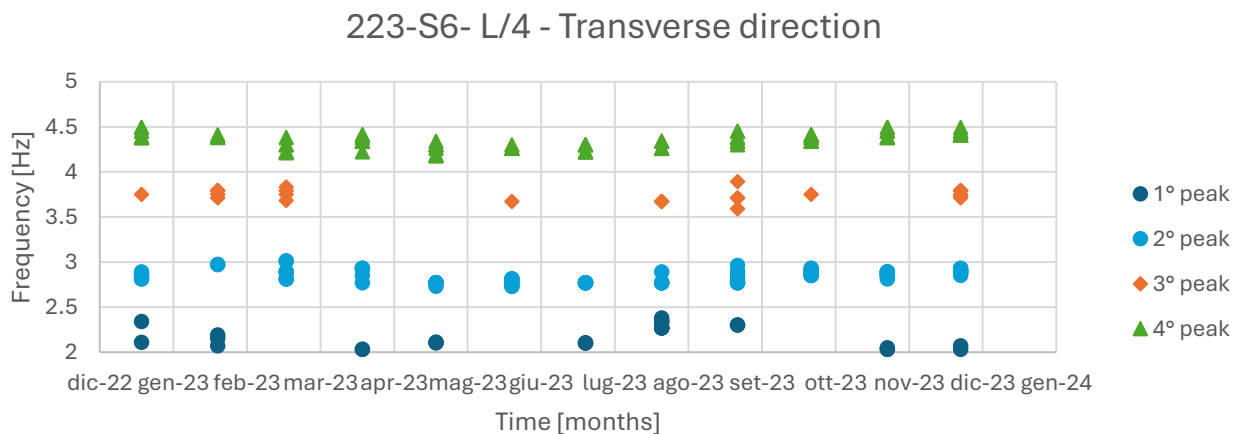

Figure 6-8: 223- S6 - L/4 - Natural frequencies obtained in transverse direction

6.3 223 SP6 L/8 Sensor 2BCAF

All the obtained frequencies have been now classified and represented in such a way to obtain the variation of the values during the year. So, the peaks value has been separated and the representation for the vertical, longitudinal and transverse direction have been obtained.

Table 6-4 2023 natural frequencies [Hz] identified for sensor 2BCAF – 223 SP6 L/8

	Vertical direction				Longitudinal direction				Transverse direction			
	1° peak	2° peak	3° peak	4° peak	1° peak	2° peak	3° peak	4° peak	1° peak	2° peak	3° peak	4° peak
Numerosity	0	3	97	99	102	52	105	101	34	95	9	64
MEAN		2.96	3.71	4.37	2.32	2.89	3.66	4.34	2.08	2.86	3.78	4.34
SD		0.02	0.05	0.04	0.06	0.06	0.09	0.07	0.18	0.08	0.06	0.17
C.o.V.		0.6%	1.3%	1.0%	2.5%	1.9%	2.5%	1.7%	8.7%	2.9%	1.6%	4.0%
Rating		3%	95%	100%	90%	48%	93%	96%	20%	82%	9%	51%
1 gen-23			3.79	4.41			3.75	4.42				
2 gen-23					2.34		3.75	4.45	2.93	3.79	4.38	
3 gen-23			3.75	4.41	2.38		3.75					
1 gen-23			3.79	4.45	2.27		3.75	4.41	2.93			
2 gen-23			3.71	4.45	2.34		3.71	4.45	2.93	3.79	4.41	
3 gen-23			3.71	4.45			3.75	4.41	2.89			
1 gen-23				4.45	2.34		3.71	4.41		3.75		
2 gen-23			3.75	4.41	2.38		3.63	4.38				
3 gen-23			3.71	4.49			3.71	4.45	2.89		4.38	
1 feb-23			3.75	4.38	2.34		3.71	4.34	2.15	2.97	3.83	4.38
2 feb-23			3.75	4.38	2.1	2.93	3.75	4.38	1.91	2.85	3.83	4.34
3 feb-23			3.75	4.38	2.35		3.63	4.38		3.09		4.38
1 feb-23			3.75	4.41	2.38	2.93	3.71	4.34		2.85	3.82	4.34
2 feb-23			3.79		2.11	2.93	3.75	4.34	2.15	2.96	3.82	4.38
3 feb-23			3.79	4.41	2.38		3.71	4.38		3.09		4.38
1 feb-23			3.75	4.38	2.16		3.75	4.34		3.01	3.75	4.73
2 feb-23			3.75	4.38	2.38	2.89	3.71	4.38				
3 feb-23			3.75	4.38	2.38	2.89	3.71	4.41				
1 mar-23			3.71	4.34	2.34	3.01	3.55	4.3		2.81		4.22
2 mar-23			3.71	4.34	2.34	2.85	3.67	4.26		2.89		
3 mar-23			3.71	4.38	2.34	2.96	3.75	4.3		3.04		4.3
1 mar-23			3.71	4.34	2.3		3.55	4.3		2.81		4.18
2 mar-23			3.71	4.34	2.3	2.85	3.67	4.22		2.89		
3 mar-23			3.71	4.38	2.34	2.89	3.71	4.34		3.09		4.26
1 mar-23			3.71	4.34	2.34	3.01	3.55	4.3		2.81		4.22
2 mar-23			3.71	4.38	2.34	2.85	3.67	4.22		2.89		
3 mar-23			3.75	4.38	2.34		3.79			2.85		
1 apr-23			3.75	4.38	2.34		3.67	4.26		2.93		
2 apr-23			3.75	4.41	2.3	2.93	3.75	4.41		2.77		4.22
3 apr-23			3.67	4.3	2.34		3.67	4.34		2.81		
1 apr-23			3.79	4.38	2.3		3.67	4.26		2.93		
2 apr-23			3.79	4.34	2.3	2.93	3.75	4.41		2.73		4.22
3 apr-23				4.38	2.3	2.93	3.71	4.34		2.85		

Monitoring activity on Fiorenza Node of A4 Highway

1	apr-23		3.75	4.38	2.34		3.71	4.26		2.93		4.22
2	apr-23		3.75	4.38	2.3	2.93	3.78	4.41				
3	apr-23			4.38			3.71	4.38	1.99	2.89		
1	mag-23		3.67	4.34	2.27	2.85	3.52	4.34	1.95	2.77		4.14
2	mag-23	2.93	3.71	4.34	2.3	2.81	3.67	4.3		2.77		4.26
3	mag-23		3.52	4.34	2.34		3.52	4.3		2.77		
1	mag-23		3.67	4.34	2.26	2.85	3.52	4.34	1.91	2.77		4.1
2	mag-23	2.97	3.67	4.34	2.34	2.77	3.67	4.3	1.91	2.77		4.22
3	mag-23		3.51	4.34	2.34		3.55	4.3		2.73		
1	mag-23		3.71	4.34	2.27	2.85	3.52	4.38	1.95	2.77		4.14
2	mag-23		3.71		2.3	2.81	3.67	4.3	1.91	2.77		4.26
3	mag-23	2.97	3.67	4.34	2.34		3.55	4.3		2.77		
1	giu-23		3.67	4.34	2.34	2.85				2.81		4.92
2	giu-23		3.71	4.3	2.38	2.97	3.71	4.34	2.3	2.81		4.26
3	giu-23		3.71	4.34	2.34	2.85	3.51	4.26		2.89		
1	giu-23		3.71	4.3	2.34	2.89						
2	giu-23		3.67	4.34	2.38		3.55	4.34				
3	giu-23		3.71	4.34	2.38	2.85	3.71	4.22				
1	giu-23			4.34	2.34	2.89				2.81		4.84
2	giu-23		3.71	4.3	2.38		3.71		2.3	2.81		4.22
3	giu-23		3.71	4.33	2.38	2.93	3.71	4.3				
1	lug-23		3.71	4.34	2.34		3.63	4.26		2.77		
2	lug-23		3.71	4.3	2.38		3.55	4.18		2.81		4.18
3	lug-23			4.3	2.34	2.85	3.55	4.18		2.73		4.22
1	lug-23		3.67	4.3	2.34		3.63	4.3		2.77		
2	lug-23		3.67	4.3	2.38		3.55	4.18		2.81		4.3
3	lug-23			4.3	2.3		3.55	4.18		2.73		4.34
1	lug-23		3.71	4.3	2.34		3.63	4.26		2.77		4.18
2	lug-23		3.71	4.34	2.34	2.81	3.48	4.3		2.77		4.22
3	lug-23			4.3	2.3	2.81	3.55	4.19		2.73		
1	ago-23		3.75	4.34	2.34	2.85	3.59	4.21	2.3	2.81		4.8
2	ago-23		3.67	4.3	2.34		3.75	4.34	2.3	2.81	3.63	4.3
3	ago-23		3.75		2.34		3.55	4.38	2.3	3.04		
1	ago-23		3.75	4.38	2.34	2.85	3.59	4.21	2.3	2.81		4.8
2	ago-23		3.75		2.34		3.79	4.34	2.3	2.81		4.3
3	ago-23		3.67	4.3	2.34		3.55	4.41		3.04		
1	ago-23		3.71	4.34	2.34	2.85	3.59	4.21	2.38	2.85		
2	ago-23				2.34		3.75	4.34	2.38			
3	ago-23		3.71		2.34		3.59			2.89		4.34
1	set-23		3.63	4.38	2.34	2.85	3.48	4.34		2.81		4.3
2	set-23		3.63	4.38	2.34	2.85	3.51	4.3	1.84	2.85		4.3
3	set-23		3.71		2.34	2.96	3.55	4.34		2.97		4.38
1	set-23		3.63	4.38	2.3	2.85	3.48	4.34		2.81		4.3
2	set-23		3.63	4.38	2.34	3.01	3.55	4.38		2.96		4.38
3	set-23		3.71	4.38	2.34	2.89	3.48	4.26	1.8	2.85		4.34
1	set-23		3.63	4.38	2.3	2.85	3.48	4.34		2.81		4.3
2	set-23		3.67	4.38	2.3		3.55	4.38		2.85		4.26
3	set-23		3.71				3.67	4.26		2.97		4.38
1	ott-23		3.71	4.38	2.15	2.85	3.75	4.41	2.26	2.89		4.3

Monitoring activity on Fiorenza Node of A4 Highway

2	ott-23		4.41	2.34		3.59	4.34		2.89		
3	ott-23	3.75	4.41	2.27		3.59	4.38		2.81	4.34	
1	ott-23	3.75	4.41	2.15		3.75	4.41	2.26	2.89	4.3	
2	ott-23	3.75	4.41	2.34	2.85	3.59	4.34		2.89		
3	ott-23		4.41	2.27	2.81	3.63	4.38		2.81	4.8	
1	ott-23		4.41	2.15		3.75	4.41	2.26	2.89	4.3	
2	ott-23	3.75	4.41	2.3		3.75	4.3		2.89	4.38	
3	ott-23	3.75	4.41	2.3		3.67	4.34		2.89		
1	nov-23		3.71	4.41	2.38		3.67	4.41	1.91	2.85	4.25
2	nov-23		3.71	4.41	2.38	2.93	3.67	4.41	2.03	2.85	
3	nov-23		3.71	4.41	2.38		3.79	4.41	1.91	2.85	4.45
1	nov-23		3.71	4.41	2.34		3.67	4.38	1.88	2.89	4.25
2	nov-23		3.71	4.41	2.38	2.89	3.67	4.41	2.03	2.85	
3	nov-23		3.71	4.41	2.34		3.79	4.38		2.89	
1	nov-23		3.71	4.41	2.34		3.75	4.38	2.03	2.85	
2	nov-23		3.71	4.41	2.34	2.89	3.71	4.38	1.88	2.85	4.25
3	nov-23		3.75	4.41	2.34		3.67	4.38	1.88	2.85	4.45
1	dic-23		3.75	4.41	2.38		3.71	4.34	2.07	2.93	
2	dic-23		3.75	4.38	2.38	2.93	3.79	4.45		2.93	4.41
3	dic-23		3.75	4.41	2.38	2.97	3.79	4.53		2.89	4.3
1	dic-23		3.71	4.41	2.38		3.71	4.34	2.07	2.93	
2	dic-23		3.71	4.38	2.19	2.93	3.75	4.38		2.93	4.38
3	dic-23		3.71	4.41	2.38	2.93	3.79	4.53		2.93	4.3
1	dic-23		3.75	4.38			3.63	4.38		2.93	4.14
2	dic-23		3.75	4.41	2.34		3.71	4.34	2.03	2.93	
3	dic-23		3.75	4.38	2.34		3.75	4.38			

6.3.1 Vertical direction (x)

223-S6-L/8 - Vertical direction

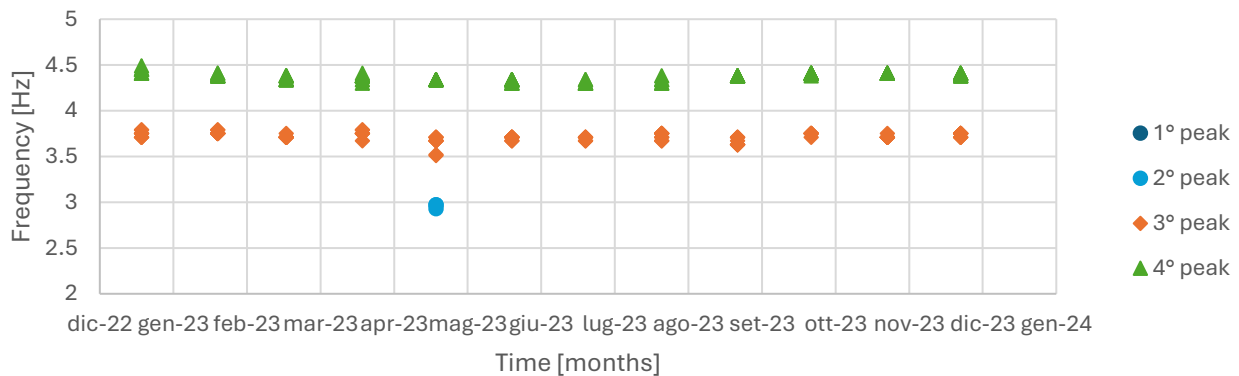

Figure 6-9: 223- S6 – L/8 - Natural frequencies obtained in vertical direction

6.3.2 Longitudinal direction (y)

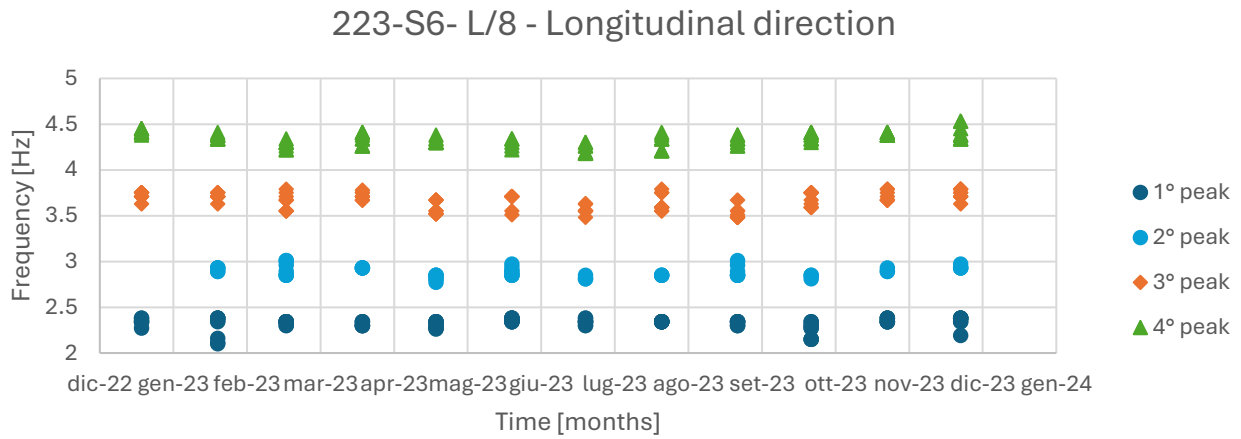

Figure 6-10: 223- S6 – L/8 - Natural frequencies obtained in longitudinal direction

6.3.3 Transverse direction (z)

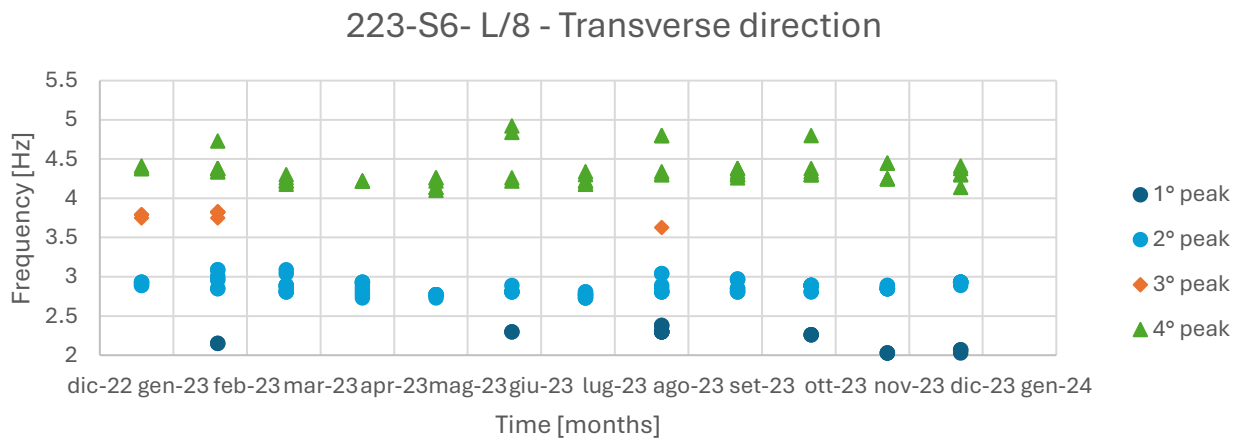

Figure 6-11: 223- S6 - L/8 - Natural frequencies obtained in transverse direction

7. SAP model

The finite element model has been created using the commercial software SAP2000 ver22.

The model consists of beam type elements and shell elements. Specifically:

- longitudinal and transverse steel beams beam elements;
- concrete piers beam elements;
- concrete slab shell elements;
- foundation footings shell elements;
- expansion joints spring elements.

Foundations rest on a bed of springs of stiffness 26 kg/cm^3 , which gives a vertical settlement of 1 mm under the action of structural and nonstructural permanent loads.

Structure 2A2 and structure 233 are modeled together because they share a common pier. The global model is shown in Figure 7-1.

The global model directions are:

- X longitudinal direction of 2A2;
- Y transverse direction of 2A2;
- Z vertical direction.

2A2 bridge consists of 11 simply supported decks. All the decks have a span of 25.00 m.

Each deck is made of 2 longitudinal steel beams, transverse steel beams and concrete slab. The longitudinal beams rest directly on circular concrete piers that are not connected at the top. A detail of the modeling of the 2A2 structure is shown in Figure 7-2.

233 bridge consists of 12 simply supported decks.

Each deck is made of 4 longitudinal steel beams, transverse steel beams and concrete slab. The decks have variable length (between 20.50 and 30.50m). The longitudinal beams rest directly on circular concrete piers that are not connected at the top. A detail of the model of 233 bridge is shown in Figure 7-3.

The joints between the different decks are modeled with springs. It was noted that the stiffness of this element affects the overall behavior of the structure significantly. Two modeling assumptions were, therefore, made:

- Model A: undamaged joint with a unit length stiffness of 200 kg/mm/m ;
- Model B: completely blocked joint with infinite stiffness.

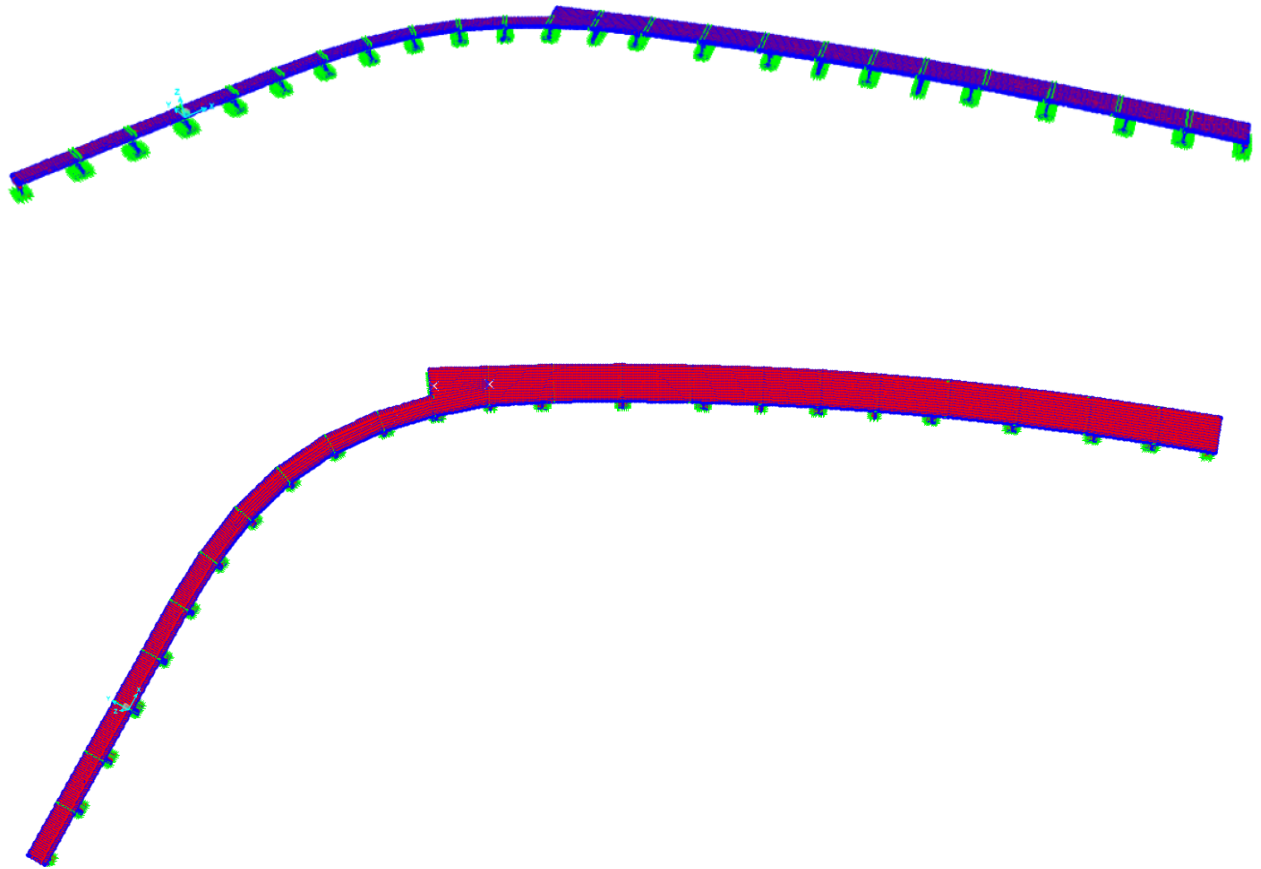

Figure 7-1: Global model of structures 2A2 and 233.

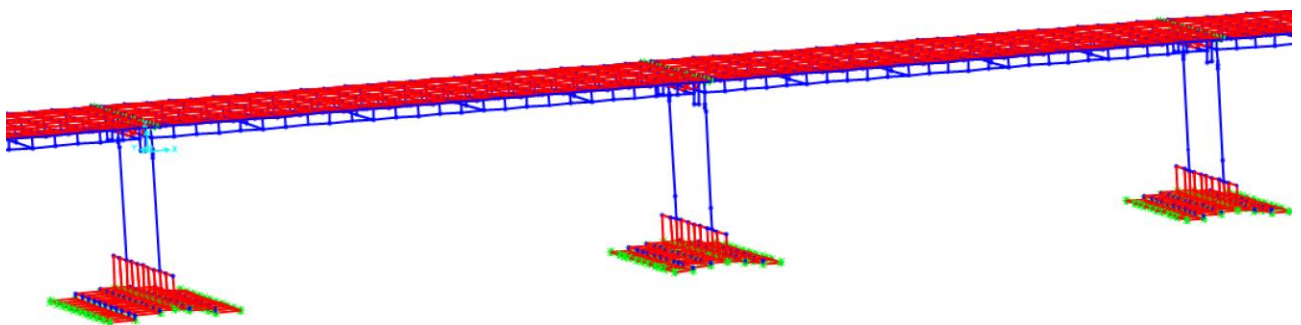

Figure 7-2: Detail of the model of structure 2A2.

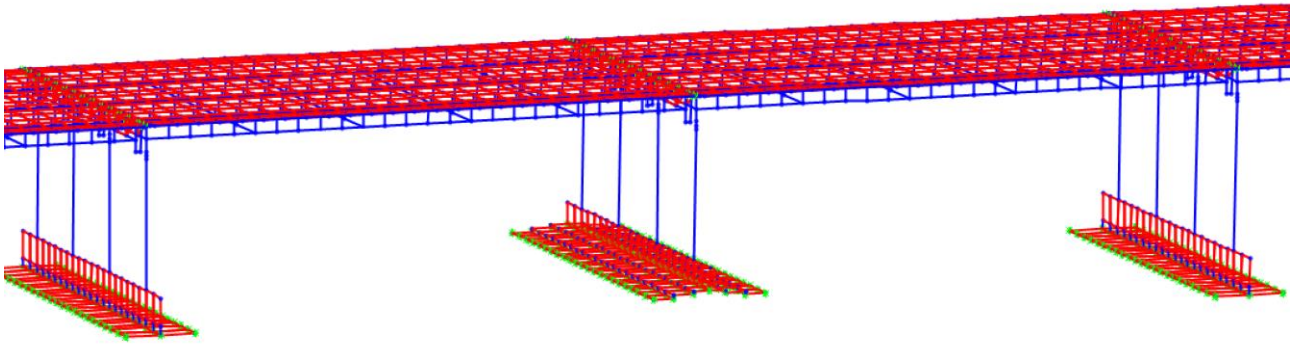

Figure 7-3: Detail of the model of structure 233.

7.1 Definition of SAP model – 2A2 bridge

The definition of the FEM is done using a commercial software called SAP2000. Both beam and shell elements are employed to define the overall structure.

The 2A2 bridge is composed of 11 spans, each one characterized by a length of 25m.

Each span is made of two steel longitudinal beams and a reinforced concrete top slab (see Figure 7-4).

Each beam is supported by one pier on one side, and it is hanged on the following beam at the other end.

Beam elements are used for piers, longitudinal and transverse beams, for the stringers, and for the links used to connect the different structural elements. Shell elements are used for foundations, deck slabs and abutments. All the structural elements have been represented along their longitudinal axis. Rigid links are used in order to connect the different elements representing their physical dimension.

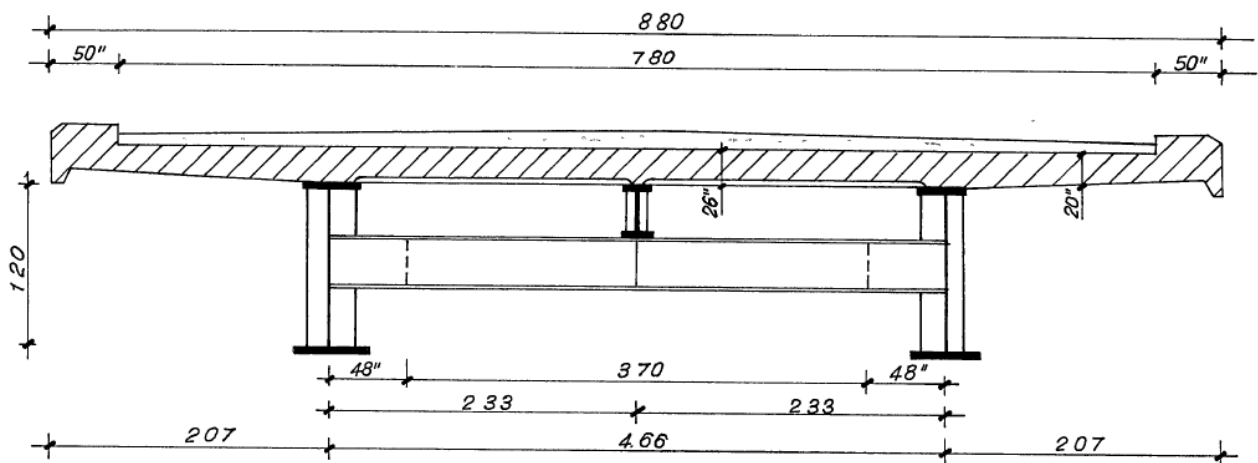

Figure 7-4: 2A2 Transverse section

The steel used is Fe430C (UNI 7070), which corresponds to the S275J0 (UNI EN 10027).

The beam section used are:

- Variable section for the longitudinal beams (constant depth but variable thickness of the plates);
- IPE450 for the transverse beams;
- IPE400 for the central stringer.

The longitudinal beams are connected by transverse beams, which have a spacing of 5m. In the middle, one stringer is used to give a central longitudinal support to the slab. The properties of the IPE beams are reported in the Table 7-1.

Table 7-1: IPE properties

	IPE400	IPE450
Outside height [m]	0.4	0.45
Top flange width [m]	0.18	0.19
Top flange thickness [m]	1.35E-02	1.46E-02
Web thickness [m]	8.60E-03	9.40E-03
Bottom flange width [m]	0.18	0.19
Bottom flange thickness [m]	1.35E-02	1.46E-02

The longitudinal beam is characterized by vertical plate of 12x1200mm, a horizontal main lower plate of 500x25mm and an upper one of 400x20mm. To give a higher rigidity and resistance to this beams, longitudinal plates are welded to the top and lower flanges along the entire length of 25.00m as shown in Figure 7-5.

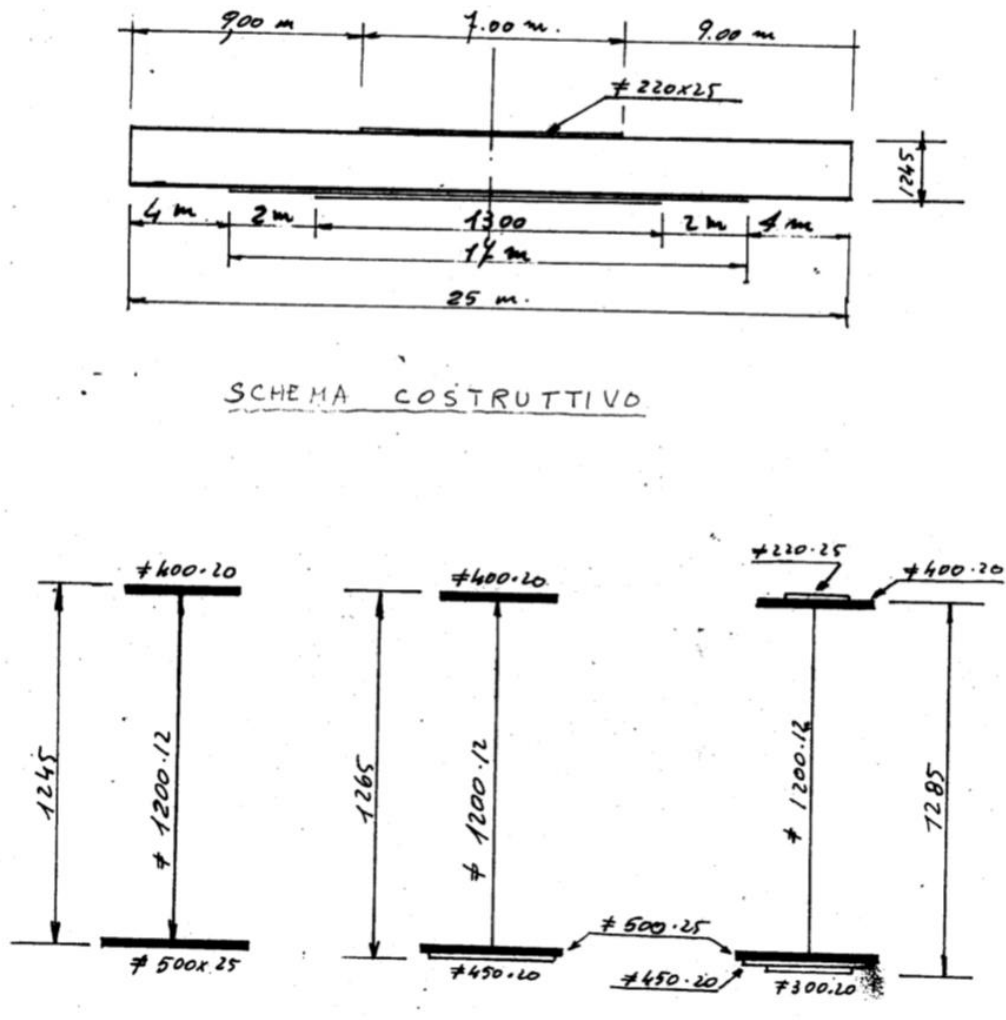

Figure 7-5: Longitudinal beam

For defining this typology of beam in SAP2000, an equivalent thickness of the upper and lower flange has been computed.

1. Upper plate thickness

- For the central 7m:

$$A_{tot} = 400 * 20 + 220 * 25 = 13500 \text{ mm}^2$$

$$h_{eq} = \frac{13500 \text{ mm}^2}{400 \text{ mm}} = 33,75 \text{ mm}$$

2. Lower plate thickness

- For the central 13m:

$$A_{tot} = 500 * 25 + 450 * 20 + 300 * 20 = 27500 \text{ mm}^2$$

$$h_{eq} = \frac{27500 \text{ mm}^2}{500 \text{ mm}} = 55 \text{ mm}$$

- For the lateral 2m:

$$A_{tot} = 500 * 25 + 450 * 20 = 21500 \text{ mm}^2$$

$$h_{eq} = \frac{21500 \text{ mm}^2}{500 \text{ mm}} = 43 \text{ mm}$$

By putting together all the thicknesses 4 different sections for the longitudinal beam have been defined:

Table 7-2: Longitudinal beam section

	Lower plate [mm]	Upper plate [mm]
Section 1	500x25	400x20
Section 2	500x43	400x20
Section 3	500x55	400x20
Section 4	500x55	400x33.75

Considering the entire length of the beam of 25.00m, section 1 was used from 0m to 4.00m, section 2 from 4.00m to 6.00m, section 3 from 6.00m to 9.00m, section 4 from 9.00 to 16.00m, section 3 from 16.00m to 19.00m, section 2 from 19.00 m to 21.00m and finally section 1 from 21.00m to 20.00m.

All the properties of the different sections used for the longitudinal beams are reported in the Table 7-3.

Table 7-3: Variable section longitudinal beams properties

	Section 1	Section 2	Section 3	Section 4
Outside height [m]	1.245	1.263	1.275	1.289
Top flange width [m]	0.40	0.40	0.40	0.40
Top flange thickness [m]	0.02	0.02	0.02	0.034
Web thickness [m]	0.012	0.012	0.012	0.012
Bottom flange width [m]	0.50	0.50	0.50	0.50
Bottom flange thickness [m]	0.025	0.043	0.055	0.055

The thickness of the concrete deck is 26cm and is constant in the middle part of the section, while in the external part it starts to become thinner, till arriving to 20cm. It was represented by using thick shell elements. After the deck has been defined over the entire structure, it was divided into smaller rectangular elements with a length lower than 1m. The deck is not an independent structure, but it needs to work together with the longitudinal beams, the transverse beams and the stringers, so through rigid links it has been connected to the other structural elements.

The piles present on this bridge have circular cross-section. They are characterized by a diameter of 1.00m. Their section also has been defined by using beam elements. The height of the piles is reported in the Table 7-4. All the piles are situated at an interaxle spacing equal to 4.66m.

Table 7-4: 2A2 height piles

Stakes number	Pile height [m]
33	4.67
32	6.13
31	5.21
30	4.51
29	4.44
28	4.53
27	4.63
26	4.55
25	4.80
24	4.64
23	4.68

Two different types of spread footing are present: type A and type B. The footing of type B is present on stakes 33, 32 and 31, while the footing of type A is present on the stakes 30, 29, 28, 27, 26, 25, 24 and 23. For defining this typology of structure, shell elements has been used. After the definition of this typology of elements, a bed of springs of stiffness equal to 26 kg/cm³ have been applied. This value has been defined be keeping in mind that a settlement lower 1mm in vertical direction need to be obtained under the application of the structural and not structural permanent loads.

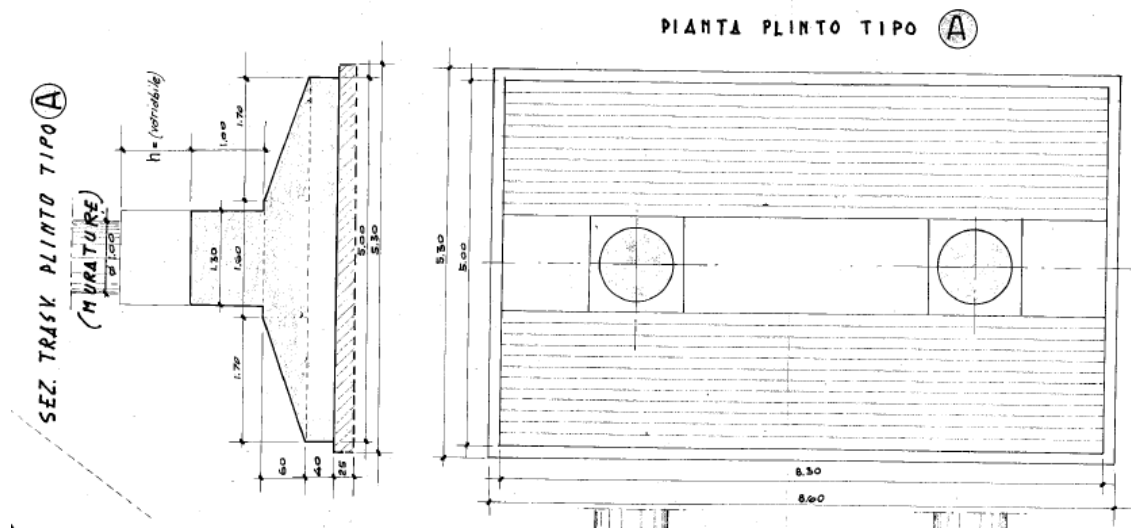

Figure 7-6: 2A2 horizontal section of the spread footing - Type A

To define the trapezoidal equivalent section of the type A foundation, three different shell elements characterized by different thicknesses have been implemented (see Figure 7-7).

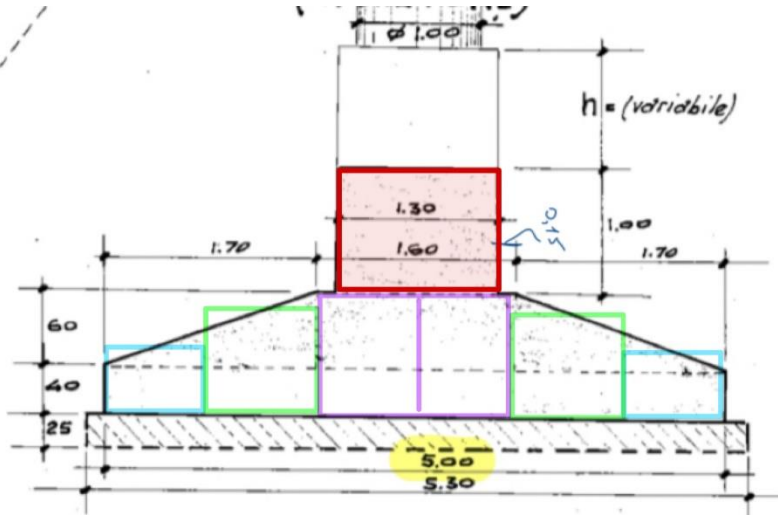

Figure 7-7: 2A2 vertical section of the spread footing - Type A

The first central shell element is characterized by a length of 0.8m and a thickness of 1.00m. The green one is 0.85m thick, while the blue one is 0.55m. Moreover, like can be seen from Figure 7-7, in the foundation of type A, is also present a quadratic enlargement at the base of the pier. This enlargement is represented in red. This typology of footing has a transverse length of 5.00m. All the shell elements positioned at a different level are connected between them through rigid links.

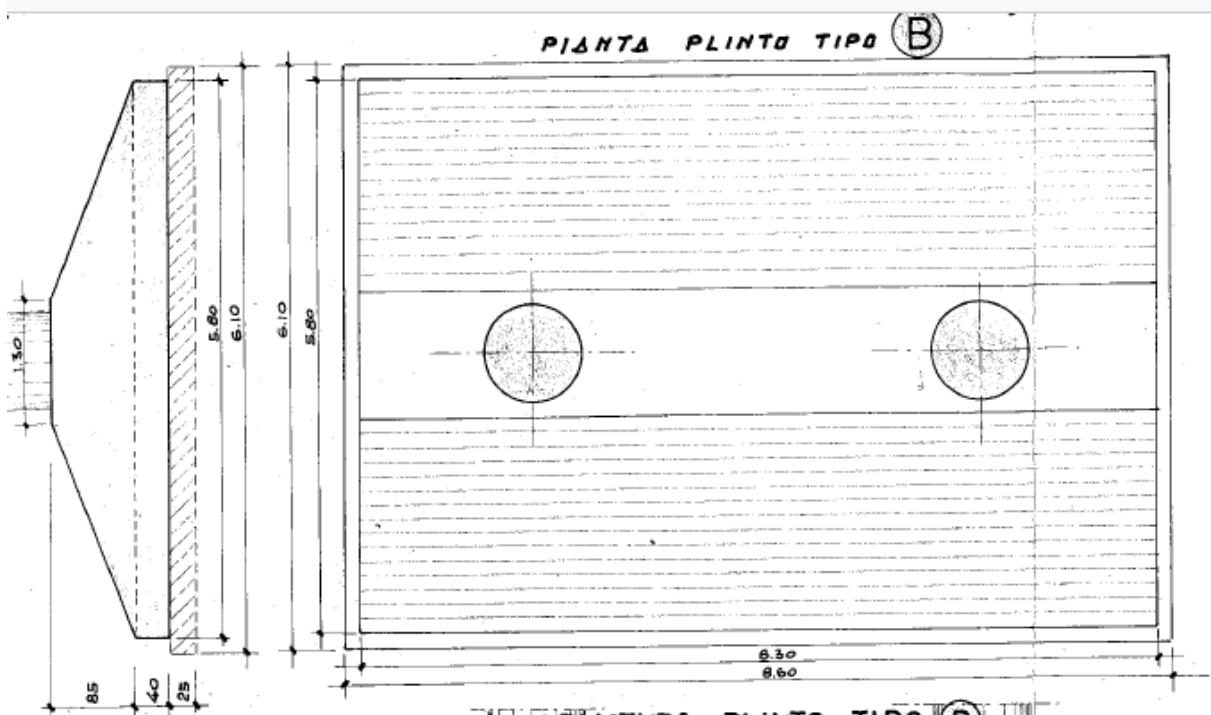

Figure 7-8: 2A2 horizontal section of the spread footing - Type B

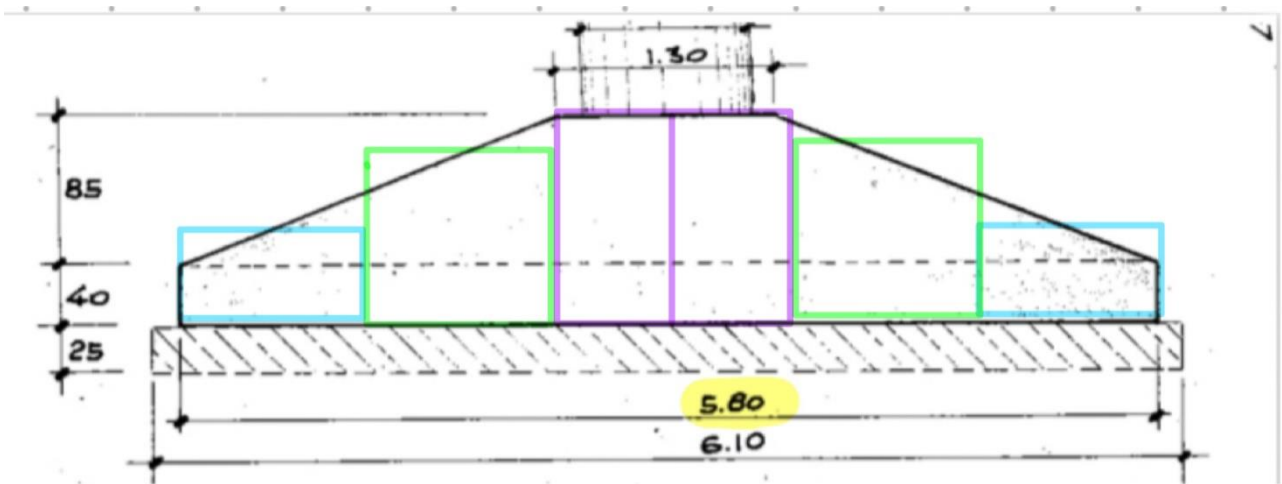

Figure 7-9: 2A2 vertical section of the spread footing - Type B

The shell elements thicknesses for the type B footing are different. In this case the central shell elements are 1.25m thick, the green one 1.03m and the blue one 0.61m. Another difference with respect to the type A footing, is that in this case the transverse section length is equal to 5.80m.

The longitudinal beams are connected to the pillar through a particular typology of elements, which are characterized by a higher rigidity in one direction with respect to the other. This type of connection is represented in the Figure 7-10 and 7-11.



Figure 7-10: Longitudinal beam - pile connection

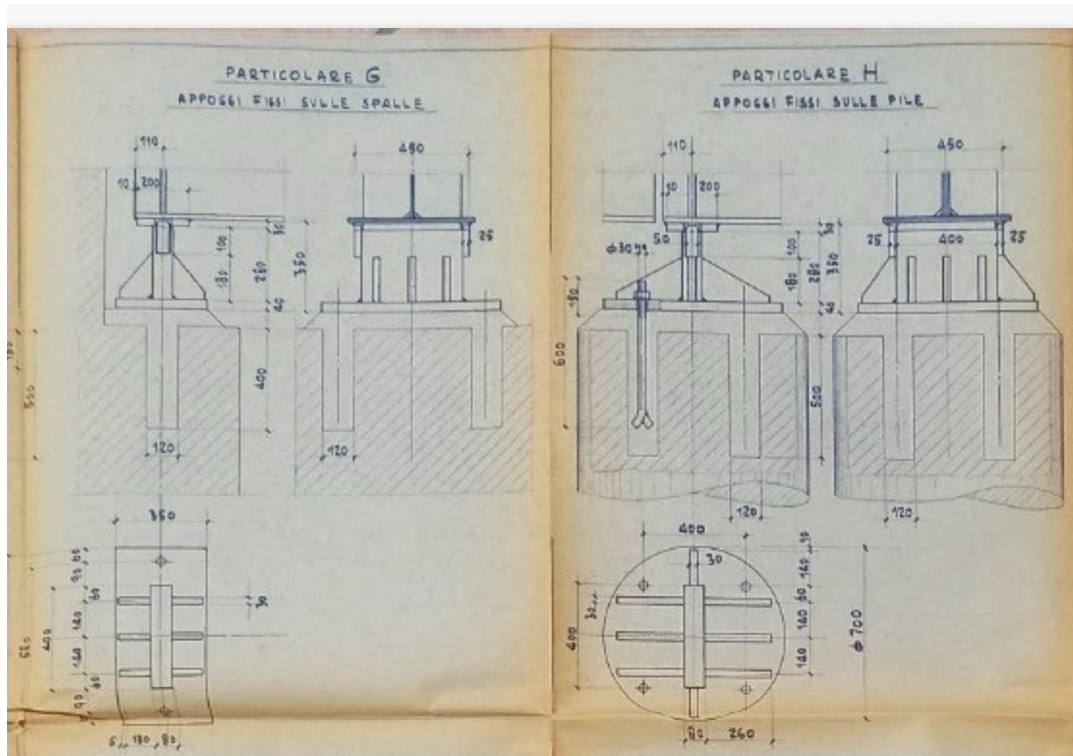

Figure 7-11: Longitudinal beam - pile connection

For defining this type of elements connection in SAP2000, a modifier value has been applied to the inertia of the element used, to obtain an element with similar properties like the real one. The base element used in the FEM is a rectangular section characterized by dimension of 400x80mm.

The inertia value of the base element is: $I_2 = 4.267 * 10^{-4} m^4$ and $I_3 = 1.707 * 10^{-5} m^4$.

While the total inertia of the element used in the construction of the bridge is:

- $I_{2real} = 4.267 * 10^{-4} + 4.57 * 10^{-6} = 4.31 * 10^{-4}$
- $I_{3real} = 1.707 * 10^{-5} + 8.79 * 10^{-5} = 1.05 * 10^{-4}$

So, the modifiers applied to the section reported in SAP2000 are equal to:

- $modifier_{I_2} = \frac{I_{real}}{I_2} = \frac{4.31 * 10^{-4}}{4.267 * 10^{-4}} = 1.0107$
- $modifier_{I_3} = \frac{I_{real}}{I_3} = \frac{1.05 * 10^{-4}}{1,707 * 10^{-5}} = 6.1482$

The connection between two consecutive decks is ensured by a specific type of element called slider. Its representation is reported in the next figure (see Figure7-12). To this element, a release of the moment about the major axis is applied. This element connection has a rectangular cross-section, defined by a dimension of 0.18m x0.07m.

PARTICOLARE APPOGGIO MOBILE - A BIELLA -

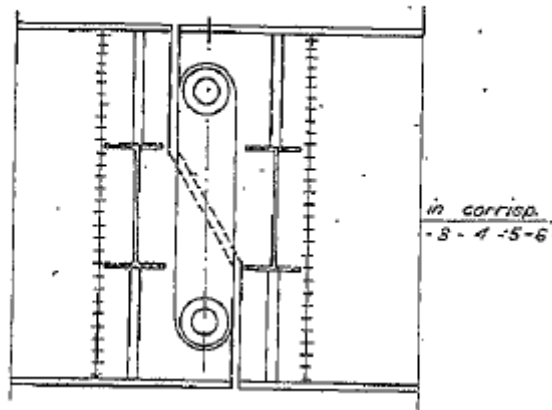

Figure 7-12: Slider connection

An abutment is present in Turin direction. It is characterized by a pile of a diameter of 1.00m and a rectangular spread footing of a thickness equal to 1.00m. Also, an earth retaining wall with a thickness equal to 0.50m is present. All the dimensions of the abutment are reported (see the Figure 7-13).

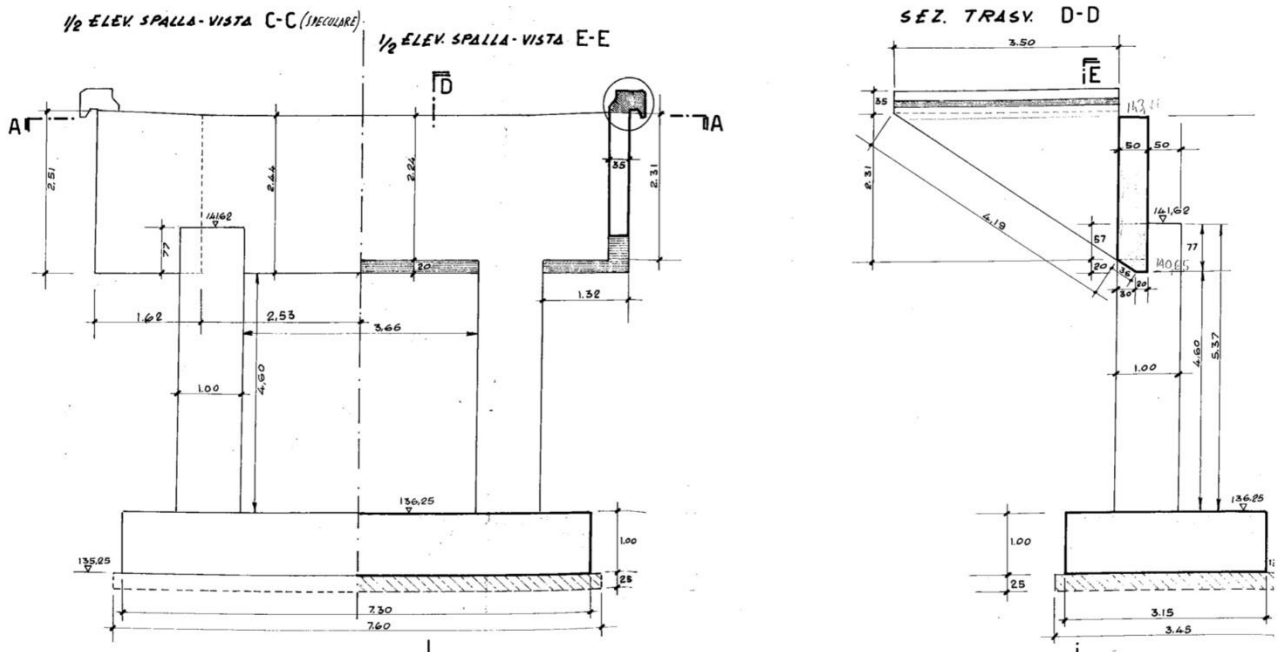

Figure 7-13: Abutment - direction Turin

Like in the previous cases, for the columns a beam type section was used, while for the other elements which are present in the abutment, shell elements have been used.

The curb element was designed by using a beam element. It has a rectangular section of 0.5m x 0.15m.

At this point the structural and nonstructural permanent loads have been applied to the overall structure. The structural loads are already kept inside the FEM by considering the typology of material used for structural element. While the nonstructural permanent loads are:

1. Pavement = 1.80 kN/m²;
2. Vehicle Restraint System = 0.75 kN/m.

These loads have been combined by applying to them the correspondent partial coefficient factor.

The pavement load has been applied to the carriageway defined through the shell elements, while the vehicle restraint system load has been applied to the external part of the cross-section like a linear load.

7.2 Definition of SAP model – 223 bridge

The 223 bridge is a part of the A8 motorway Milano-Varese. It is composed of 12 decks. In this case the decks haven't the same length, like in the case of 2A2 bridge, but it varies between 25m and 30.5m. In the next table are reported the different span lengths of the decks.

Table 7-5: 223 deck span

Deck number	Deck length [m]
1	25.00
2	30.50
3	30.50
4	30.50
5	30.50
6	25.00
7	25.00
8	30.50
9	30.50
10	30.50
11	28.50
12	25.00

Also, the definition of the 223 bridge started from the individuation of its transverse section.

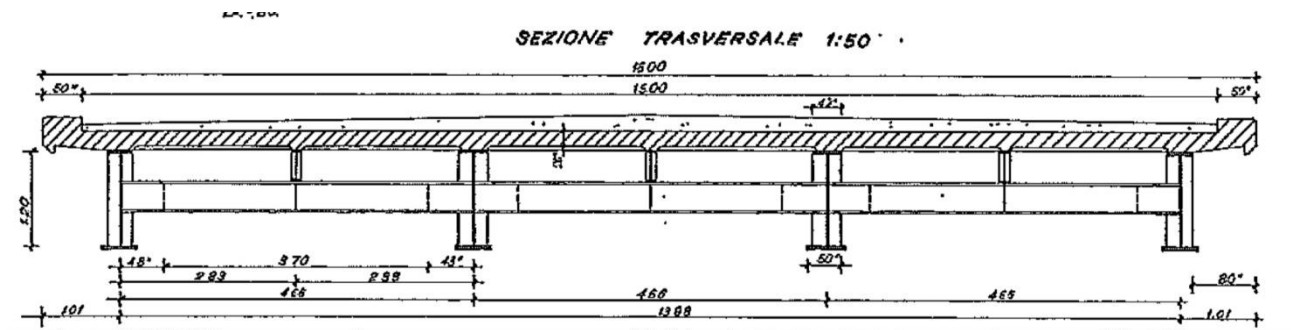

Figure 7-14: 223 - Transverse section

This transverse section is kept constant along all the length of the bridge. Its width is equal to 16.00m. One exception is the deck which divide the vehicular flow into the one which goes toward Turin (2A2 bridge) and one toward Varese. Close to the point in which the flow is divided, the deck can reach a transversal length equal to 21.03m.

In this case four longitudinal beams are present, while the 2A2 is characterized by the presence of 2 beams. Like in the previous case, they are situated at a distance equal to 4.66m.

Like for the 2A2 bridge, three different typologies of steel beams are present:

- Variable section for the longitudinal beams (constant depth but variable thickness of the plates);
- IPE450 for the transverse beams;
- IPE400 for the central stringer.

The properties of these IPE steel beams are the same as the ones of 2A2 bridge beams.

Like can be seen in the transverse section (see Figure 7-14), the thickness of the concrete deck is equal to 26 cm in the middle, while it starts to become thinner in the external part. Like previously described, the deck was modeled through shell elements.

Like in the previous case, the height of the pillars is variable. Their value varies between 4.25m and 6.72m (see table 7-6). They have circular cross-section, and the diameter is equal to 0.90m. The interaxle is equal to 4.66m and a group of 4 piles are present on each stake.

Table 7-6: 223 height piles

Stakes number	Pile height [m]
22	5.26
21	4.90
20	5.72
19	5.40
18	5.74
17	5.83
16	6.72
15	5.68
14	5.72
13	4.81
12	4.85

Also, in this case 2 different typologies of spread footings are present: type 1 and type 2. Type 1 footing is present on the stakes 21, 20, 19, 17, 15, 14, 13 and 12, while type 2 on the stakes number 22, 18 and 16. The footings of type 1 has similar geometrical dimensions as the ones of the type A of the bridge 2A2 (see Figure 7-15). The difference in this case is the dimension of the enlargement at the base of the pier. It is not quadratic but is rectangular and goes along the entire footing.

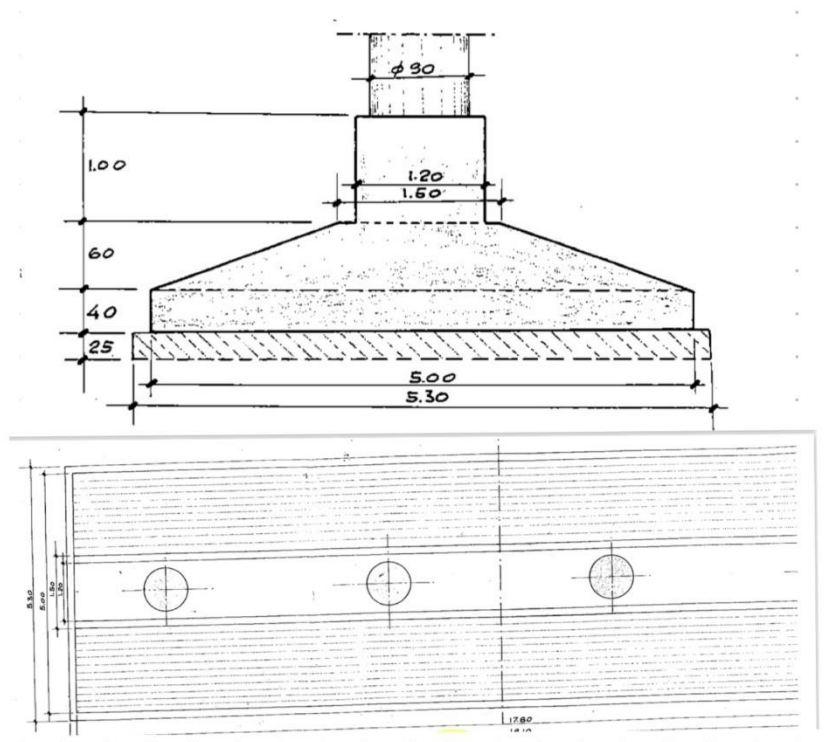

Figure 7-15: 223 Spread footing - type 1

The footing of type 2 is a rectangular spread footing. The enlargement of the pier goes along the entire structure (see Figure 7-16), like the type 1 footing. The thickness is equal to 0.75m, while the enlargement has a height equal to 1.25m.

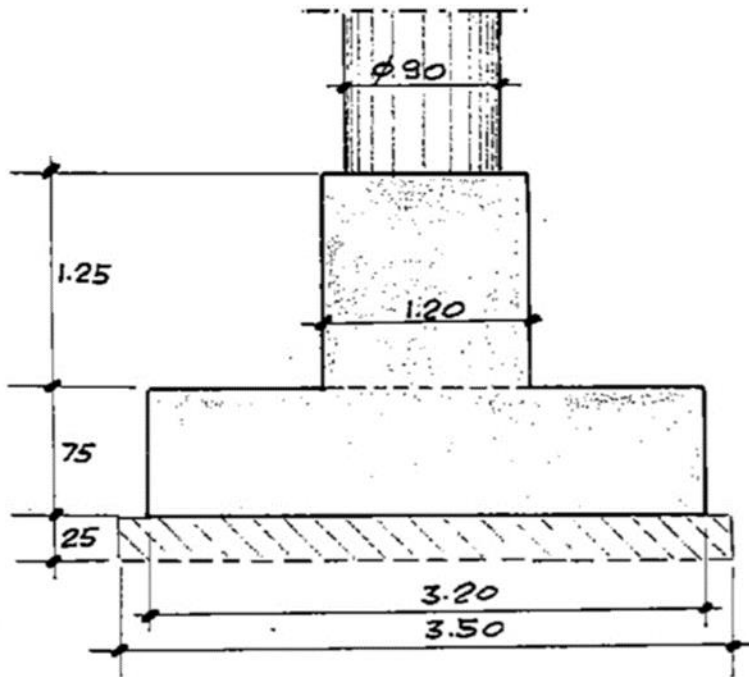

Figure 7-16: 223 vertical section of the spread footings - type 2

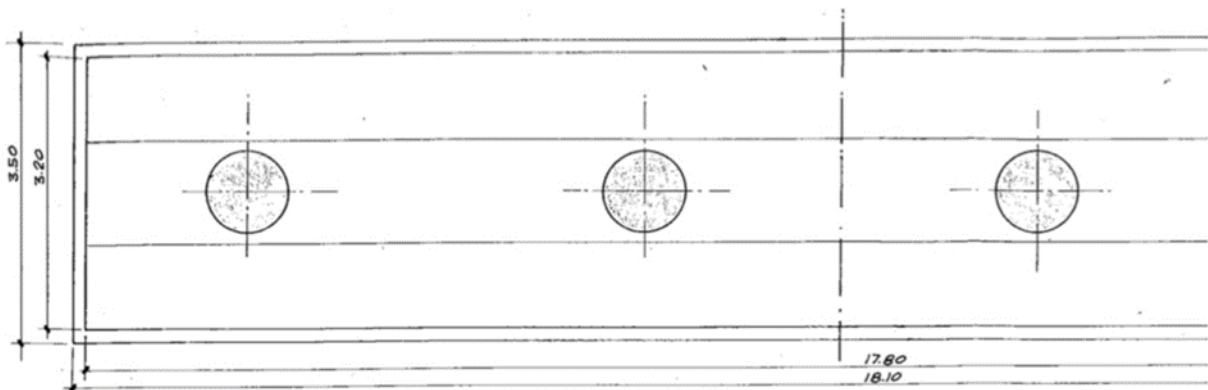

Figure 7-17: 223 horizontal section of the spread footing - type 2

Like previously described, the longitudinal beams are connected to the pillars through a specific type of element, characterized by a higher rigidity in one direction. Moreover, the connection between two consecutive longitudinal beams, is endured by the slider.

The deck number 1 is characterized by the presence of an abutment. Its geometrical properties are reported in the Figure 7-18 and Figure 7-19. The pile has been defined through beam elements, while the spread footing and the retaining wall through shell elements.

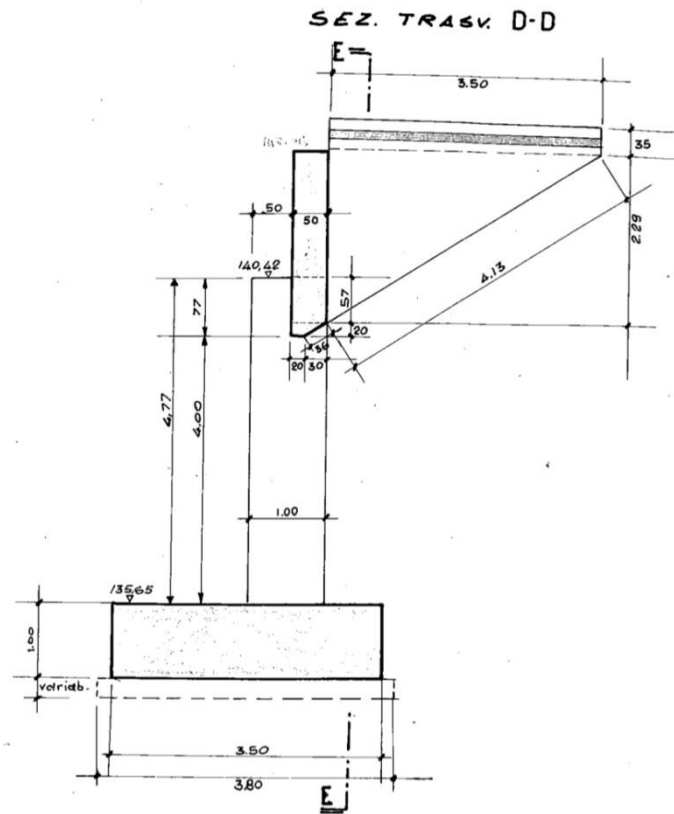

Figure 7-18: 223 abutment - transverse section

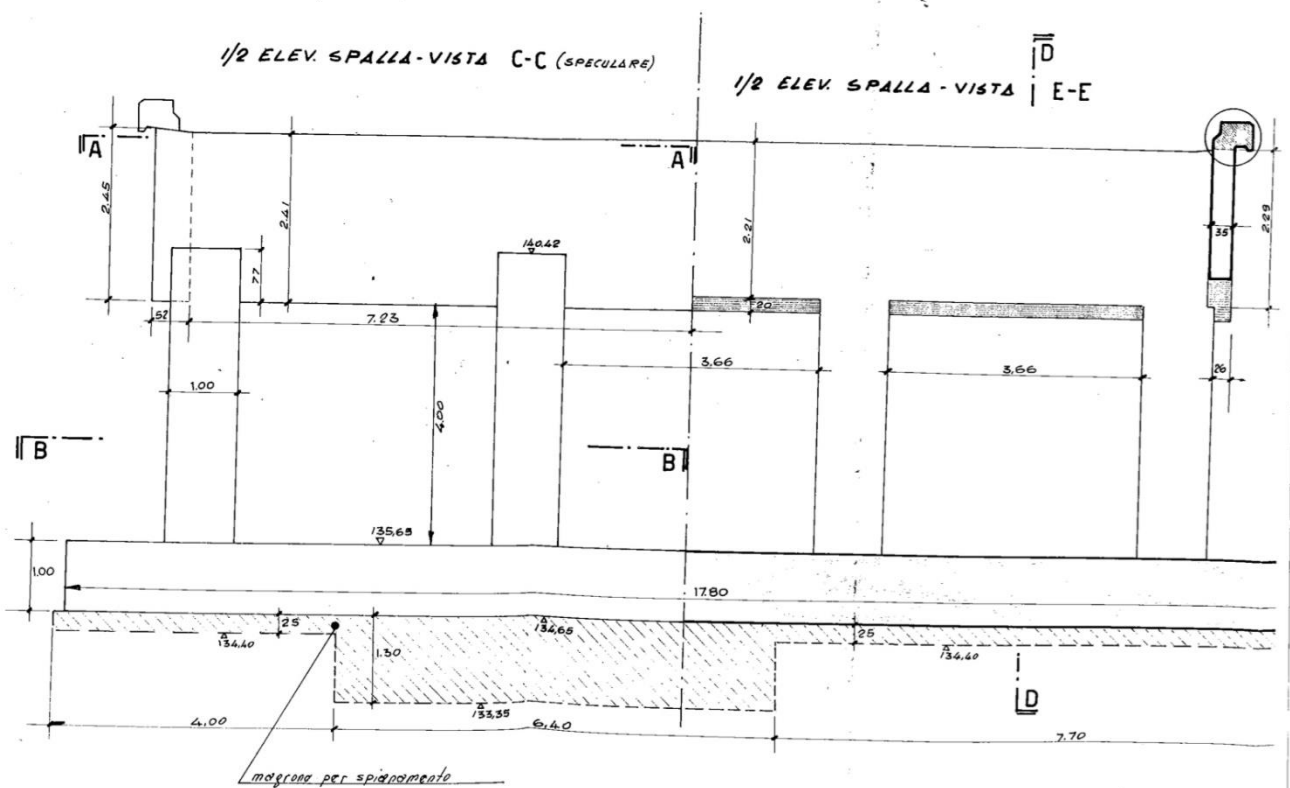

Figure 7-19: 223 abutment - longitudinal section

The curb has been defined through beam element along the entire length of the bridge. It has rectangular cross-section of dimension 0.5m x 0.15m.

Finally, the load combination has been defined. The permanent structural loads are already considered by the FEM, by considering the cross-section used and the typology of the material from which they are composed. While the permanent nonstructural loads are:

1. Pavement = 1.80 kN/m²;
2. Vehicle Restraint System = 0.75 kN/m.

Like previously specified, the pavement load has been applied to the shell elements which represent the carriageway, while the vehicle restraint system has been applied to the external part the deck.

7.3 Results of Model A

In this model at frequencies between 0.9 and 1.5 Hz there are 14 local modes due to low stiffness in transverse direction, due to the tensed pendulum support mechanism, as shown in Figure 7-20 to Figure 7-24.

The vertical modes of the decks of structure 223 occur between 1.53 and 1.57 Hz and are presented in Figure 7-25. The vertical modes of the decks of structure 2A2 occur at the frequency of 2.29 Hz and are presented in Figure 7-26.

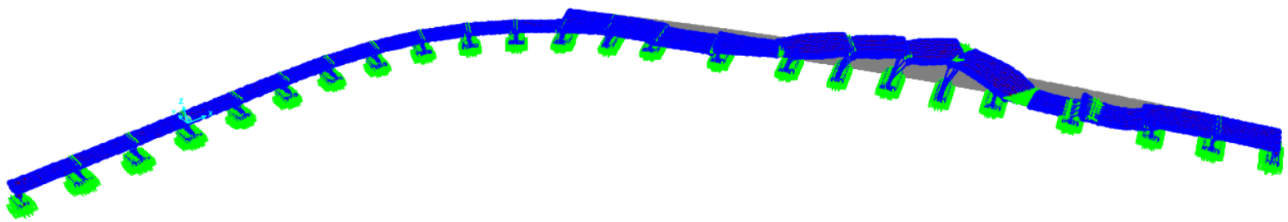

Figure 7-20: Example of local mode of model A.

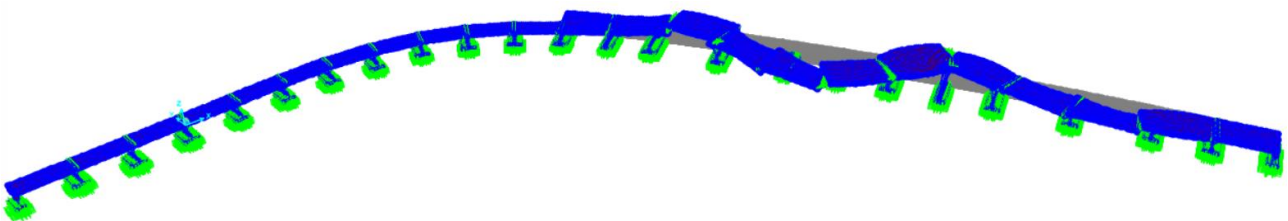

Figure 7-21: Example of local mode of model A.

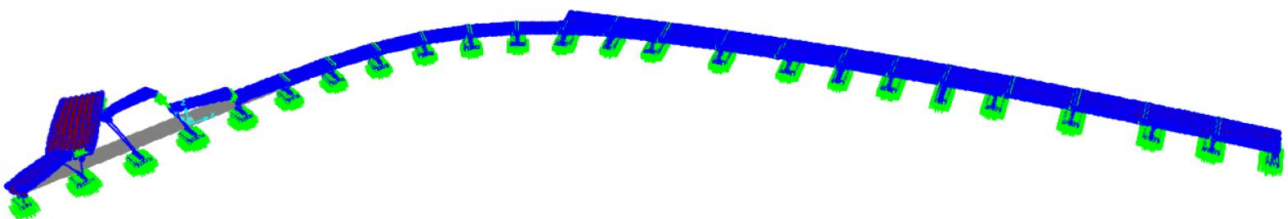

Figure 7-22: Example of local mode of model A.

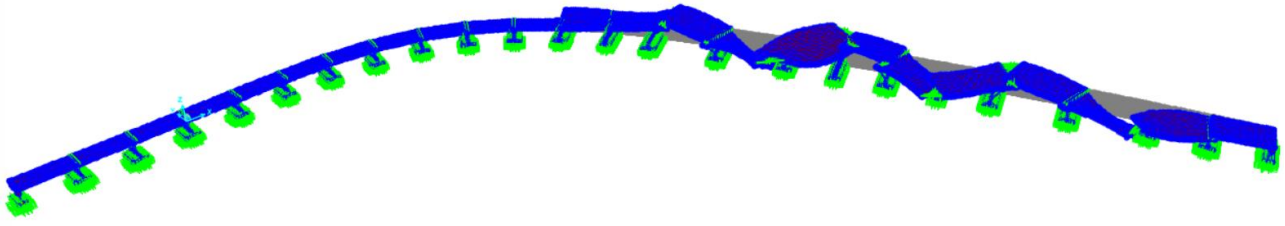

Figure 7-23: Example of local mode of model A.

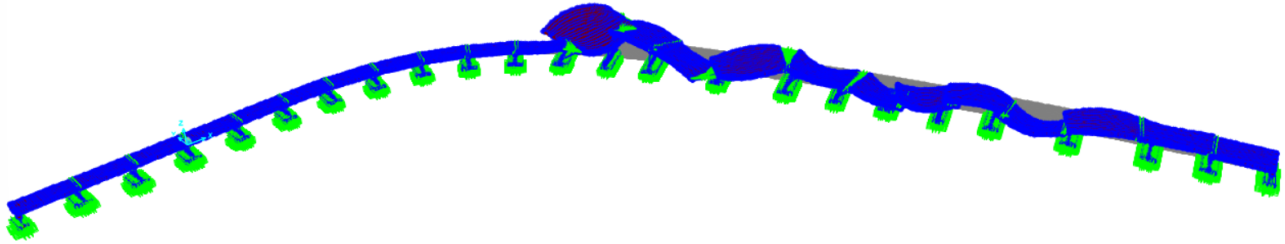

Figure 7-24: Example of local mode of model A.

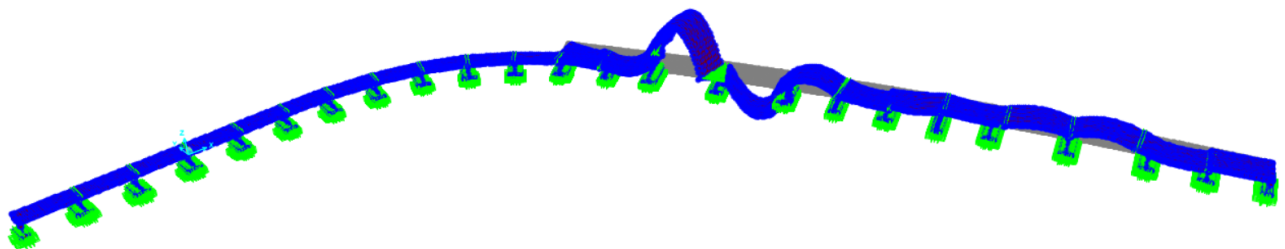

Figure 7-25: Vertical mode of the decks of structure 223 model A.

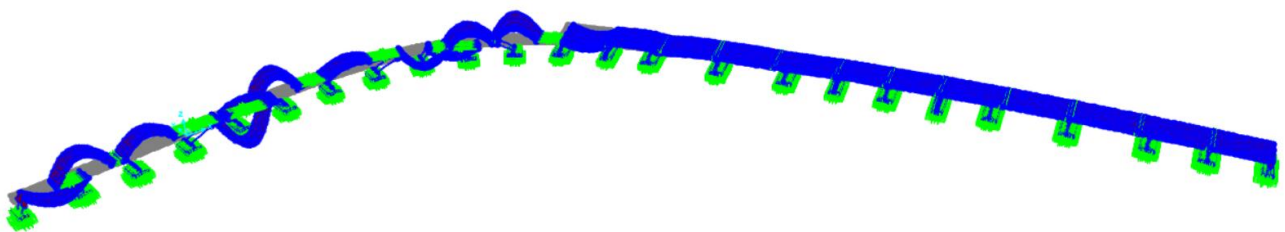

Figure 7-26: Vertical mode of the decks of structure 2A2 model A.

7.4 Results of Model B

In this model, the structural behavior is more global. The previously reported local modes are not present and are replaced by modes that involve the whole structure (see Figure 7-27 and Figure 7-28).

The vertical modes of the decks of structure 223 occur between 1.50 Hz and 1.66 Hz (see Figure 7-29). Another vertical mode present on this bridge occur between 4.39 Hz and 4.83 Hz (see Figure 7-30).

The vertical modes of the decks of structure 2A2 occur at the frequency between 2.48 Hz and 2.74 Hz (see Figure 7-31 and Figure 7-32). Like can be seen from these 2 figures, these values are characteristic also for the 223 bridge.

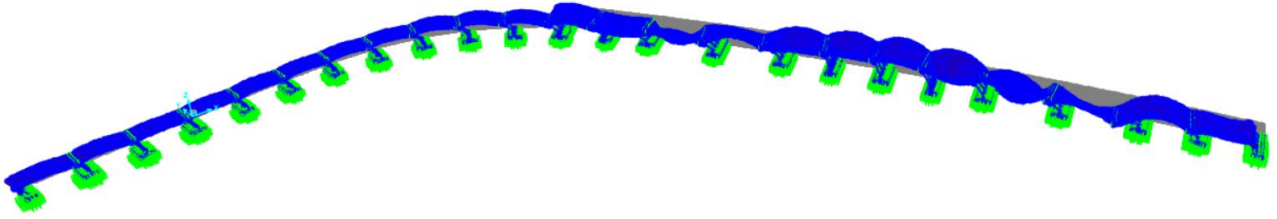

Figure 7-27: Example of global mode of model B.

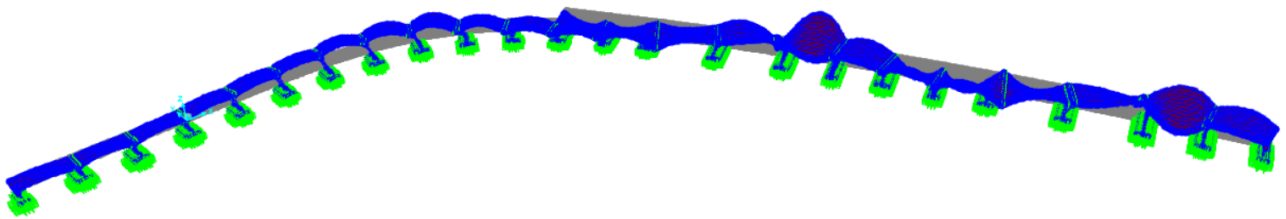

Figure 7-28: Example of global mode of model B.

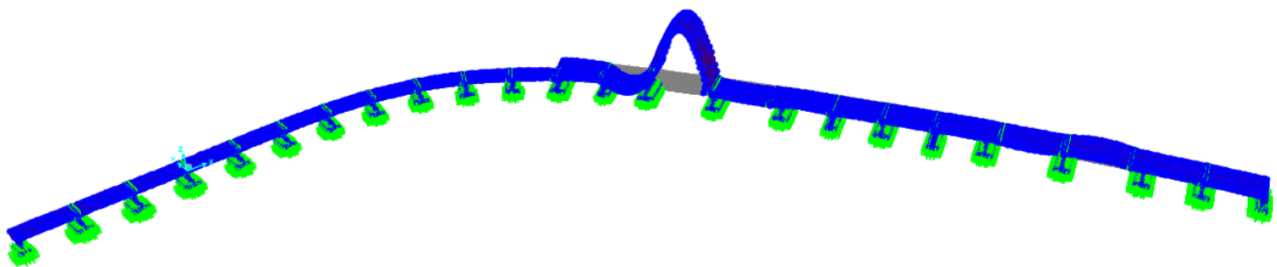

Figure 7-29: Vertical mode of the decks of structure 223 model B.

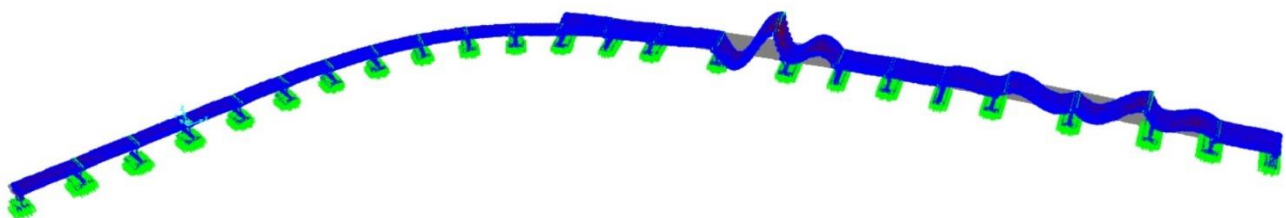

Figure 7-30: Vertical mode of the decks of structure 223 model B.

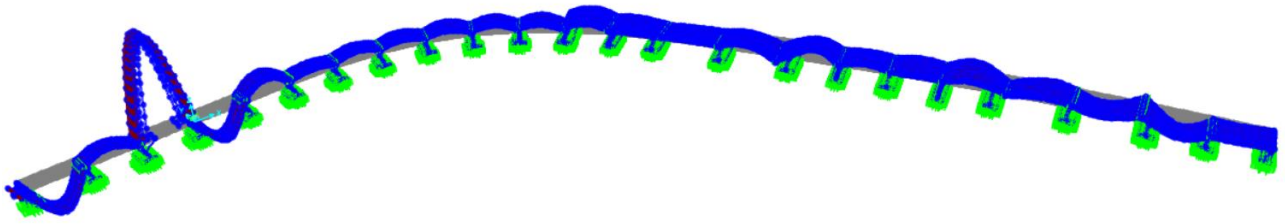

Figure 7-31: Vertical mode of the decks of structure 2A2 model B.

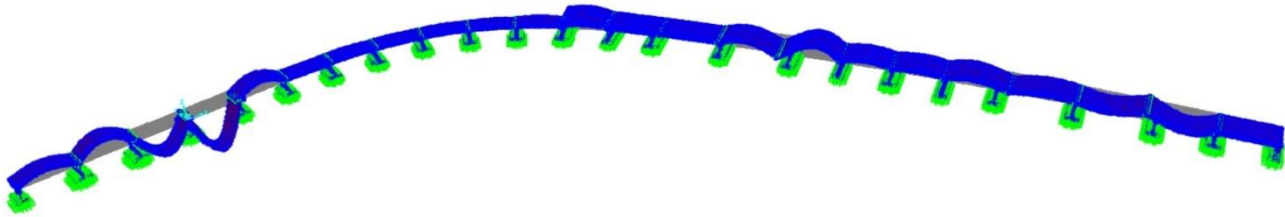

Figure 7-32: Vertical mode of the decks of structure 2A2 model B.

8. OMA Identification

Operational Modal Analysis (OMA) is a method used to determine the dynamic characteristics of structures under actual operating conditions. Compared to the traditional Experimental Modal Analysis (EMA), which always requires artificial excitation, OMA relies on operational forces acting on the structures. This makes this typology of analysis to be particularly useful for large structures, such as bridges, where artificial excitation is challenging to be applied. It is only an output-only method. This means that in order to perform this typology of analysis, only the measurement of the response of structure is needed, and not the input forces. Usually, the response acquisition is made in terms of acceleration, velocities or displacements. The primary goal of this type of procedure is the identification of the modal parameters of the structure, like for example the natural frequencies or the mode shapes. The advantages of this typology of analysis with respect to the traditional EMA are:

- is cheaper, because it reduces the need for expensive excitation systems;
- the made analysis are performed on more realistic and operational condition;
- the monitoring system does not interfere with the normal usage of the infrastructure.

In the case of the bridges on which the monitoring process is applied, the input excitation is random, and it can be caused by the wind and traffic loads. So, after the acquisitions have been made, a filtering process may be applied. But, if the registered data is disturbed by a lot of noise, caused maybe by the wrong installation of the acquisition system, no type of post-processing procedure will be useful to make usable the acquisitions.

The OMA methods can be classified by following different criteria. Each method points out a specific aspect and it help the user to select the most suitable analysis method. A first distinction can be made between parametric and nonparametric methods. If a model is fitted to data, the method is referred to be a parametric method. This method is more complex and computational demanding with respect to the nonparametric one. But they usually show better performance with respect to the second. Since nonparametric method is faster, it can be used during field test to get a quick insight about the results of dynamic identification. Another distinction can be made between SDOF and MDOF methods. This distinction is made depending on the assumption about the number of modes which determines the structural response in each bandwidth. SDOF method assumes that if only one mode is dominant, it is possible to assume that the structural response in that frequency range depends only on that mode. Moreover, this mode can be applied only if the modes of the structure are well separated. In contrast, when closely spaced or coincided modes are present, MDOF method should be applied. Finally, a third distinction which can be made, is based on the domain of implementation. So, time or frequency domain can be distinguished.

Frequency domain method is based on the spectral density function analysis. In this case, to handle the present noise in the signal, averaging procedure is applied. An example of this type of method is the Basic Frequency Domain (peak-picking) method. In this case, to identify the frequencies, a picking procedure of the peaks from the PSD plots is made.

Time domain methods are based on the analysis of response time histories. Furthermore, they are usually more suitable to handle noisy data. They take advantage from the singular value decomposition procedure to reject noise. An example of time domain method is the Covariance-Driven Stochastic Subspace Identification (Cov-SSI) method. It is a method used in case of stochastic input data, so when we must identify a stochastic state-space model from output only data. This method can be applied only when the overall system can be controlled and observed. A state system is defined like to be controllable, when it can be reached from any initial state of the system in a finite time interval by some control actions. While a state system is defined to be observable if the knowledge of the output over a finite time interval completely determinates the state. In order to have a system of order (n) that can be defined like to be observable or controllable, the correspondent observability or controllability matrix should be of rank (n). This method starts from the computation of the output correlation matrix ($[\hat{R}_i]$), at the time lag (i):

$$[\widehat{R}_l] = \frac{1}{N-i} [Y_{(1:N-i)}][Y_{(i:N)}]^T$$

where:

- $[Y_{(1:N-i)}]$ is obtained from $l \times N$ data matrix $[Y]$ by removing the last (i) samples;
- $[Y_{(i:N)}]$ is obtained from the $[Y]$ data matrix by removing the first (i) samples.

Now the Toeplitz matrix $[T_{1|i}]$ can be defined. It is composed by the estimated correlation matrixes at different time lags (i) .

$$[T_{1|i}] = \begin{bmatrix} [\widehat{R}_l] & [\widehat{R}_{l-1}] & \dots & [\widehat{R}_1] \\ [\widehat{R}_{l+1}] & [\widehat{R}_l] & \ddots & [\widehat{R}_2] \\ \vdots & \vdots & \ddots & \vdots \\ [\widehat{R}_{2l-1}] & [\widehat{R}_{2l-2}] & \dots & [\widehat{R}_l] \end{bmatrix}$$

Each correlation matrix has dimensions $l \times l$, so the Toeplitz matrix is characterized by $li \times li$ dimensions. For the identification of a system of order (n) , the number of block rows (i) has to fulfill the condition for which $li > n$.

Now a factorization property should be presented, for which one we will have:

$$[R_i] = [C][A]^{i-1}[G]$$

where:

- $[C]$ is the observation matrix;
- $[A]$ is the state matrix;
- $[G]$ is the next state-output covariance matrix.

By applying this factorization property to the block of the Toeplitz matrix, the observability and the controllability matrices will be defined.

$$[T_{1|i}] = \begin{bmatrix} [C] \\ [C][A] \\ \vdots \\ [C][A]^{i-1} \end{bmatrix} [[A]^{i-1}[G] \quad \dots \quad [A][G] \quad [G]] = [O_i][\Gamma_i]$$

where:

- $\begin{bmatrix} [C] \\ [C][A] \\ \vdots \\ [C][A]^{i-1} \end{bmatrix} = [O_i]$ is the observability matrix;
- $[[A]^{i-1}[G] \quad \dots \quad [A][G] \quad [G]] = [\Gamma_i]$ is the controllability matrix.

Both the introduced upper matrices are characterized by dimensions of $li \times n$. If the condition for which $li > n$ is fulfilled and the system is observable and controllable, the rank of the block Toeplitz matrix equals (n) . In fact, it is a product of a matrix with (n) columns $[O_i]$ and a matrix with (n) rows $[\Gamma_i]$.

Now the singular values decomposition of the Toeplitz matrix can be written like:

$$[T_{1|i}] = [U][\Sigma][V]^T = [[U_1] \quad [U_2]] \begin{bmatrix} [\Sigma_1] & 0 \\ 0 & 0 \end{bmatrix} [V_1]^T$$

Where the matrices $[U_1]$ and $[V_1]^T$ have dimensions $(li \times n)$ and $(n \times li)$, and the $(n \times n)$ diagonal matrix $[\Sigma_1]$ holds the positive singular values arranged in descending order. The matrices $[O_i]$ and $[\Gamma_i]$ can be computed by splitting the singular value decomposition in two parts:

$$[O_i] = [U_1][\Sigma_1]^{\frac{1}{2}}[T]$$

$$[\Gamma_i] = [T]^{-\frac{1}{2}} [\Sigma_1]^{\frac{1}{2}} [V_1]^T$$

The matrix $[T]$ is a nonsingular matrix which determines one of the infinite equivalent realizations of the state-space model. So, this matrix can be set equal to the identity matrix $[I]$.

Finally, the state matrix $[A]$, can be computed according to different approaches. The first one is based on the decomposition property of the one-lag shifted Toeplitz matrix:

$$[T_{2|i+1}] = \begin{bmatrix} [\widehat{R}_{i+1}] & [\widehat{R}_i] & \cdots & [\widehat{R}_2] \\ [\widehat{R}_{i+2}] & [\widehat{R}_{i+1}] & \ddots & [\widehat{R}_3] \\ \vdots & \vdots & \ddots & \vdots \\ [\widehat{R}_{2i}] & [\widehat{R}_{2i-1}] & \cdots & [\widehat{R}_{i+1}] \end{bmatrix} = [O_i][A][\Gamma_i]$$

From this expression, the state matrix can be obtained:

$$[A] = [O_i]^+ [T_{2|i+1}] [\Gamma_i]^+$$

Now, by substituting the above obtained expressions of the observability and the controllability matrices, and considering the identity matrix, the state matrix will be obtained:

$$[A] = [\Sigma_1]^{-\frac{1}{2}} [U_1]^T [T_{2|i+1}] [V_1] [\Sigma_1]^{-\frac{1}{2}}$$

Another procedure used in the definition of the state matrix is the one which use the weighting matrices. Pre- and post-multiplying the matrix $[T_{1|i}]$ by the weighting matrices $[W_1]$ and $[W_2]$, computing the singular value decomposition of the weighted Toeplitz matrix and omitting the zero singular values, yield to the following expression of the observability matrix:

$$[O_i] = [W_1]^{-1} [U_1] [\Sigma_1]^{\frac{1}{2}}$$

The state matrix is obtained by computing:

$$[A] = [O_i^\uparrow]^+ [O_i^\downarrow]$$

where $[O_i^\uparrow]$ and $[O_i^\downarrow]$ are obtained from the observability matrix $[O_i]$ by removal of the last and the first (l) rows respectively.

For defining if the obtained mode shapes are correlated between them, the Modal assurance criterion (MAC) index have been computed. The MAC index is a squared linear regression correlation coefficient, and it provides a measure of the consistency between the two vectors under comparison. Given for example an experimentally estimated mode shape ($\{\phi_n^e\}$) and a numerically predicted one ($\{\phi_n^a\}$) of the n -th mode of the investigated structure, the MAC value can be computed as follows:

$$MAC(\{\phi_n^a\}, \{\phi_n^e\}) = \frac{|\{\phi_n^a\}^T \{\phi_n^e\}|^2}{(\{\phi_n^a\}^T \{\phi_n^a\}) (\{\phi_n^e\}^T \{\phi_n^e\})}$$

Its value is enclosed between 0 and 1. For inconsistent correspondence 0 is obtained, while for perfectly consistent correspondence a MAC value equal to 1 is obtained. This value provides only a measure of consistency between the vectors, but it does not ensure validity of the analyzed vectors.

In order to identify all modes in the analyzed frequency range, some prior knowledge about the order of the model should be known. In fact, the number of modes should be estimated in advance, based for example from the peaks in the output power spectra or in the case of stochastic subspace identification the order of the model can be

defined from the rank of the Toeplitz matrix. Unfortunately, due to noise and modeling inaccuracies, it often happens that no clear gap is visible in the sequence of the singular values of those matrices. Usually, an overspecification of the order of the model is adopted, in such a way that this permits the identification of all physical modes. This operation introduces spurious poles, which must be separated from the physical ones. The spurious modes can be:

- Noise modes: they are represented by poles of the excitation system, and, as such they are due to physical reasons;
- Mathematical modes: they are created by the model in addition to the physical poles to ensure the mathematical description of the measured data. Thus, they are the result of the overestimation of the order of the model.

The separation of the physical poles from the spurious mathematical ones can be made by the construction of the stabilization diagram. It is a diagram on which abscissa we can find the frequency [Hz], while on the ordinate the model order is identified. By following the evolution of the poles, for an increasing model order, the physical modes can be identified from alignments of stable poles, since the spurious mathematical poles tend to be more irregular. The alignments of stable poles can start at lower or higher values of the model order, depending in the level of excitation of the modes. To define if a pole is stable or not, some conditions should be verified. This condition is based on the comparison of the poles associated to a given order with those obtained from a one-order lower model. The inequalities which need to be fulfilled are:

$$\left(\frac{|f(n) - f(n+1)|}{f(n)} \right) < 0.01$$

$$\left(\frac{|\xi(n) - \xi(n+1)|}{\xi(n)} \right) < 0.05$$

$$[1 - MAC(\{\phi(n)\}, \{\phi(n+1)\})] < 0.02$$

The first one indicates that the natural frequency scatter between two subsequent model orders must be lower than 1%, the damping ratio scatter should be lower than 5% and the MAC value higher than 0.98.

In the case of stochastic subspace identification methods, the stabilization diagram can be efficiently constructed once the factorization property reported has been computed for the maximum order of the model.

$$[T_{1i}] = \begin{bmatrix} [C] \\ [C][A] \\ \vdots \\ [C][A]^{i-1} \end{bmatrix} \begin{bmatrix} [[A]^{i-1}[G] & \dots & [A][G] & [G]] \\ [O_i][\Gamma_i] \end{bmatrix}$$

In fact, models of lower order can be directly obtained by excluding an increasing number of singular values in the computation of the observability ($[O_i]$) and the controllability ($[\Gamma_i]$) matrices. Moreover, the poles in complex conjugate pairs allow plotting the stabilization diagram considering only those characterized by positive imaginary components.

8.1 Description of the framework

The most energetic signal sets are selected and analyzed by the SSI-Cov method. For each month, the 3 dates where the signals are most energetic are selected. For each date, the SSI-Cov identification algorithm is applied. The algorithm provides a stabilization diagram as output, as shown in Figure 8-1. It can be seen that for the same structure, the stabilization diagram can be extremely clear (Figure 8-1 (a)) or very noisy (Figure 8-1 (b)) which depends on the signal-to-noise ratio of the examined accelerograms.

The vibration modes of the monitored system are represented by the stable pole alignments (blue dots on the stabilization diagram). Stable pole alignments are extracted by applying the DBSCAN clustering algorithm; which bases its clustering principle on the density of presence in a region. For the extraction of alignments, 2 parameters were used: the minimum number of stable poles in the alignment which must be at least 45 and the maximum frequency variation within the alignment which must be less than 0.01 Hz.

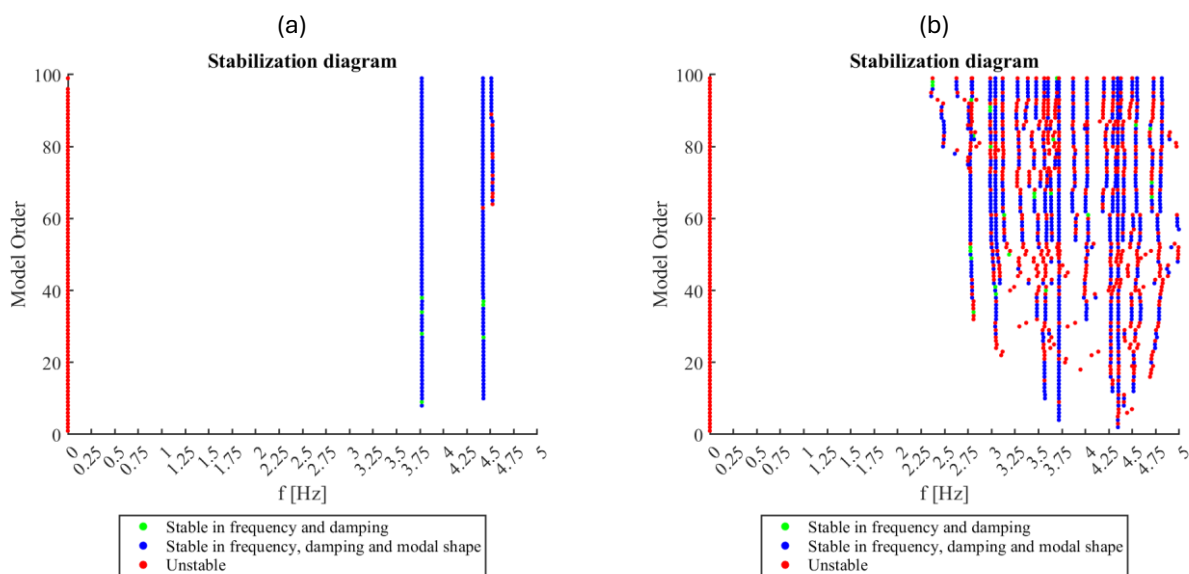

Figure 8-1: Examples of stabilization diagram. (a) January, deck 6 of opera 223. (b) March, deck 6 of opera 223.

Therefore, for each month, the identified system frequencies, damping, and modal forms are extracted. A comparison of the identified modes for each month over the entire year is then performed in order to find the repeating modes of the structure. This selection is performed based on two parameters: a maximum mode frequency variation of 0.12 Hz and a minimum MAC between modes of 0.7.

8.2 Decks 4 and 5 of bridge 2A2

The identification of modal shapes of decks 4 and 5 of bridge 2A2 is done using the three most overall energetic accelerograms for each month for the spans of the bridge. Date of the most energetic records for each month is given in Table 8-1.

Table 8-1 2023 First three most energetic accelerograms for span 4 and 5 of bridge 2A2 in 2023

Month	Date and time of Most energetic accelerograms		
	1	2	3
January	2023-01-31_07-00	2023-01-19_13-00	2023-01-17_07-00
February	2023-02-01_13-00	2023-02-06_13-00	2023-02-03_13-00
March	2023-03-16_13-00	2023-03-04_13-00	2023-03-08_13-00
April	2023-04-20_08-00	2023-04-07_08-00	2023-04-06_20-00
May	2023-05-23_14-00	2023-05-04_14-00	2023-05-19_14-00
June	2023-06-13_08-00	2023-06-27_14-00	2023-06-28_14-00
July	2023-07-17_14-00	2023-07-20_14-00	2023-07-07_14-00
August	2023-08-07_14-00	2023-08-29_08-00	2023-08-02_08-00
September	2023-09-20_11-00	2023-09-14_11-00	2023-09-26_15-00
October	2023-10-02_08-00	2023-10-19_12-00	2023-10-10_12-00
November	2023-11-07_17-00	2023-11-11_14-00	2023-11-06_17-00
December	2023-12-06_10-00	2023-12-13_08-00	2023-12-12_15-00

Results in terms of identified vibrational frequencies are reported for set 1, set 2, and set 3; respectively in Figure 8-2, Figure 8-3 and Figure 8-4.

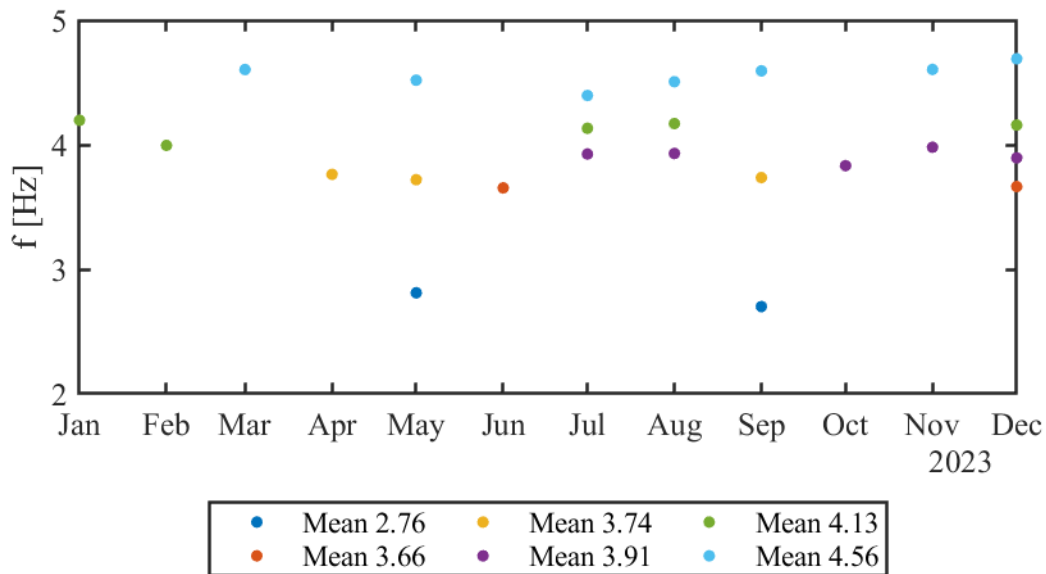

Figure 8-2: 2A2 - Identified frequencies for set 1

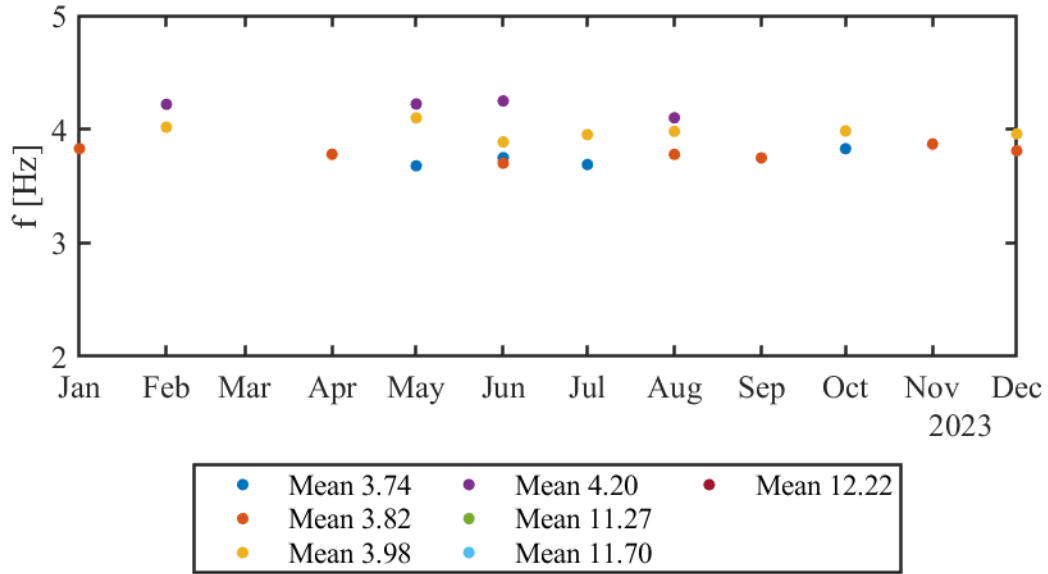

Figure 8-3: 2A2 - Identified frequencies for set 2

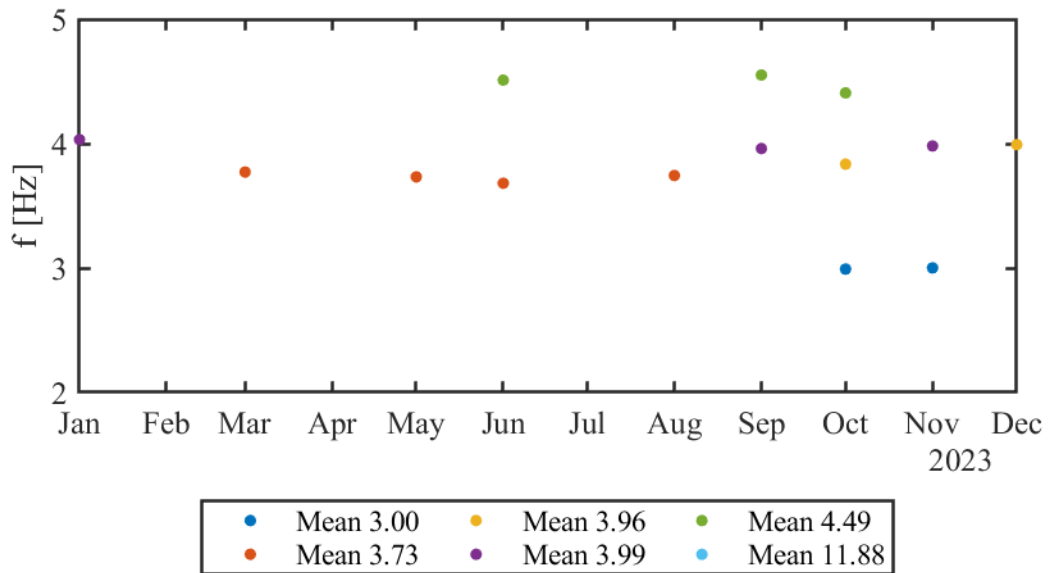

Figure 8-4: 2A2 - Identified frequencies for set 3

In order to evaluate the most frequently occurring modes that are present in all sets, the three sets are merged and the results are shown in Figure 8-5 and the modal shapes are shown in Figure 8-6.

The most frequent modes are between 3.7 Hz and 4.6 Hz. It is possible to see that some alignments are characterized by very close frequencies and similar modal shapes.

Monitoring activity on Fiorenza Node of A4 Highway

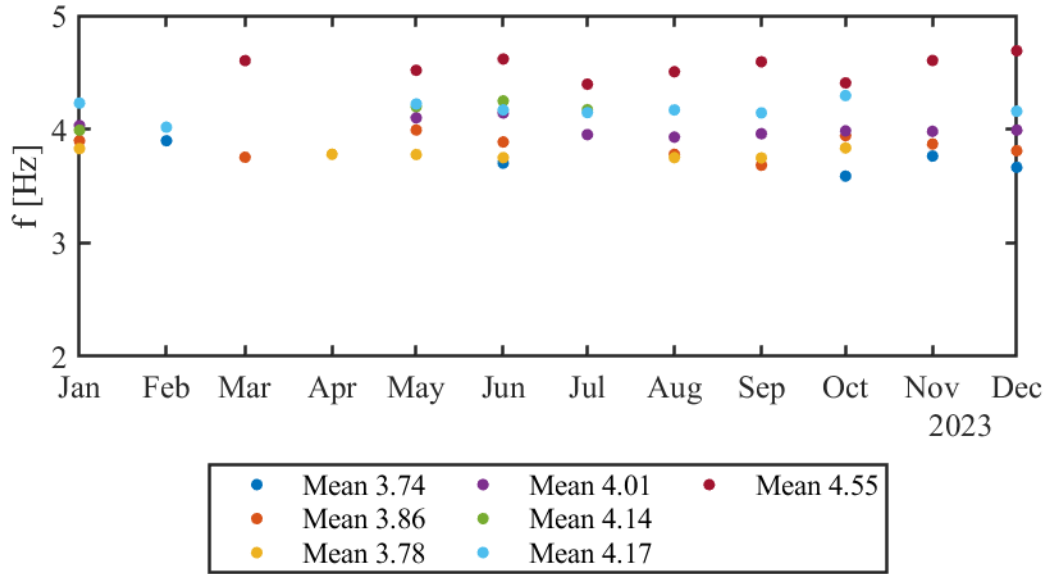
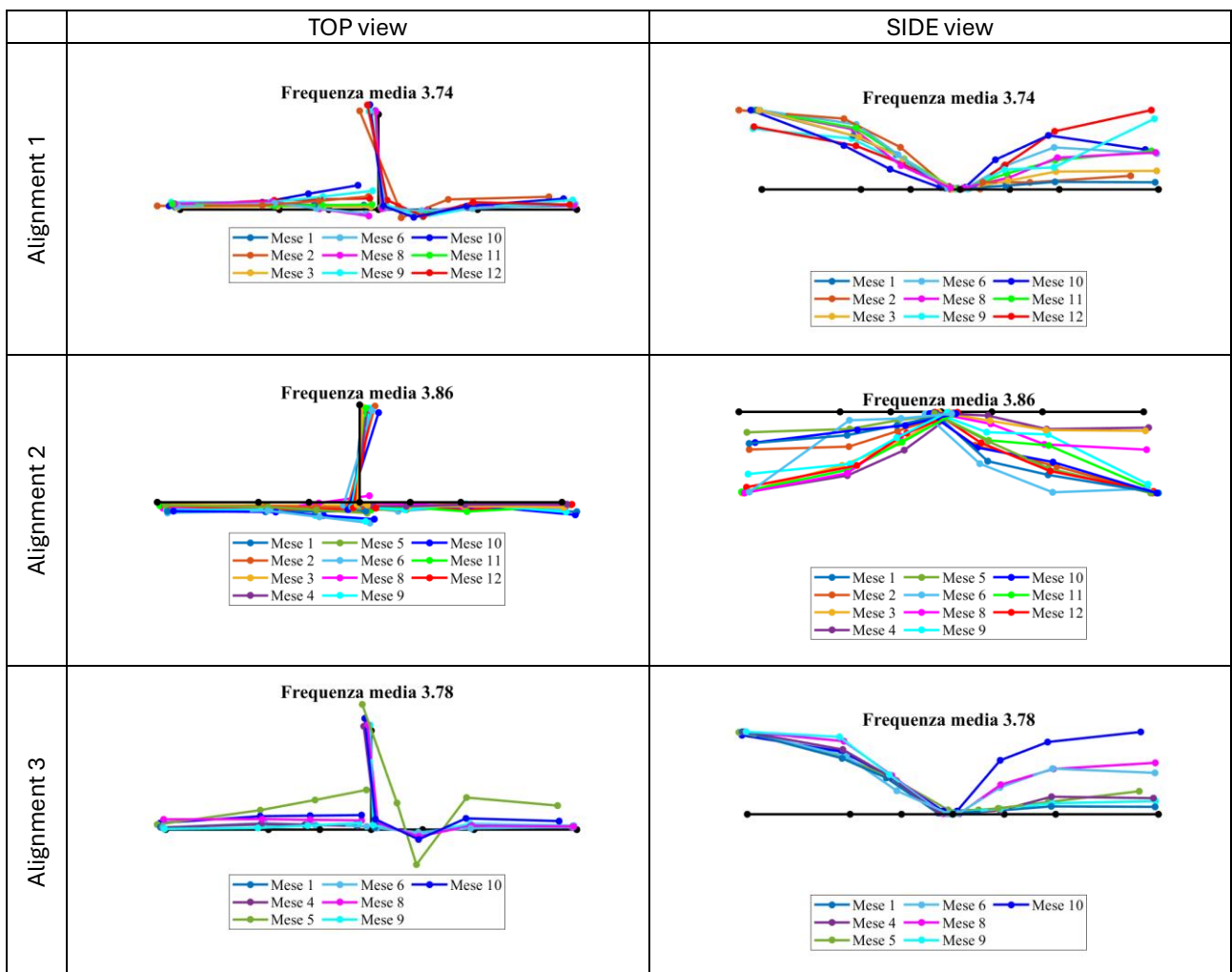

Figure 8-5: 2A2 - Identified frequencies for the merge of the sets



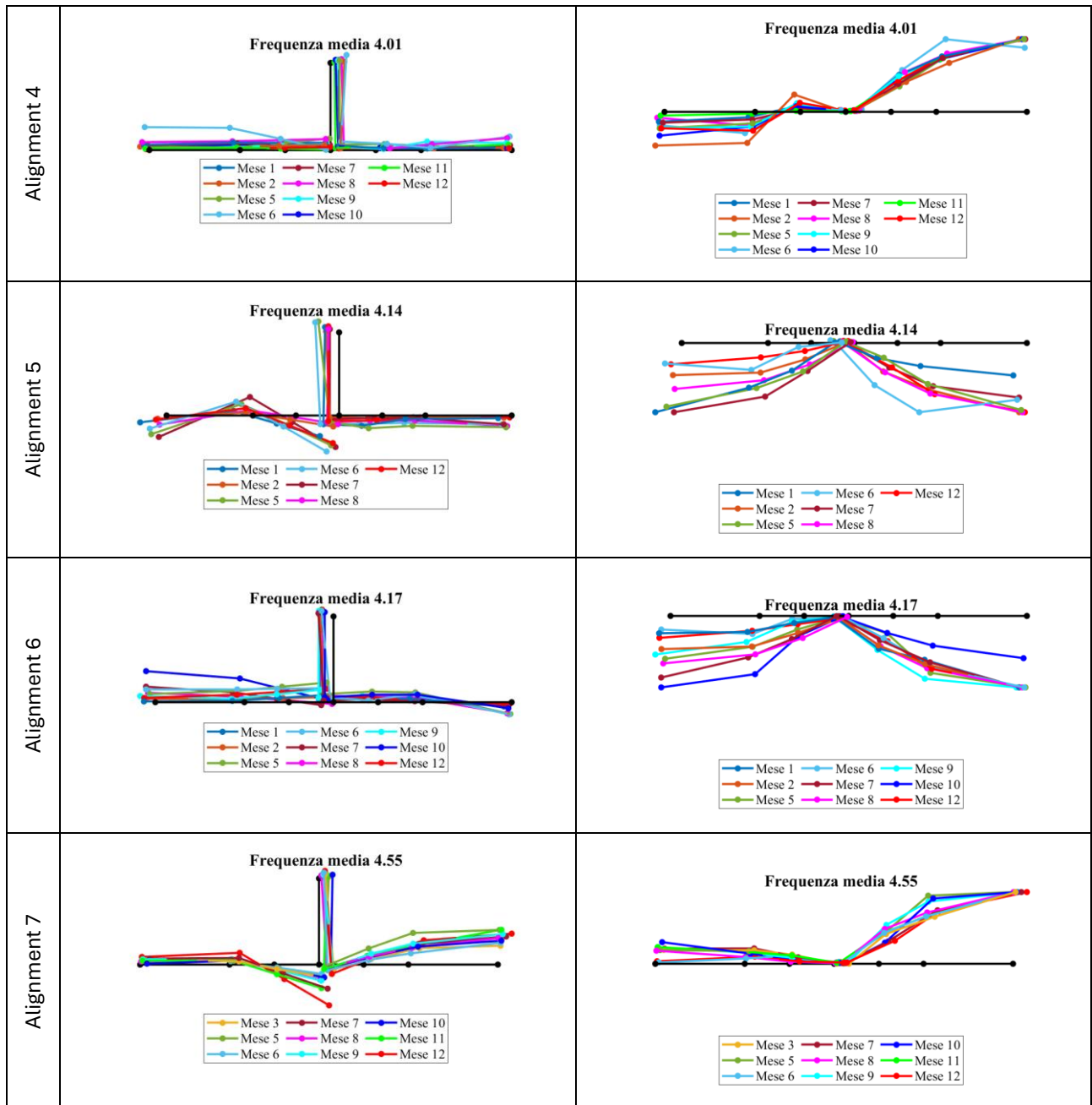

Figure 8-6: 2A2 - Modal shape of the identified modes

At this point, by analyzing the above obtained results, it can be noticed that the alignments 1 and 3 represent the same modal shape, with a slightly different value for the frequency obtained, respectively of 3.74 and 3.78 Hz. Numerically, two different frequencies have been obtained, but basically, they represent the same thing.

Both are in counterphase with the alignment 2, which frequency is equal to 3.86 Hz.

8.3 Deck 2 of bridge 223

The identification of modal shapes of deck 2 of bridge 223 is done using the three most overall energetic accelerograms for each month for the span of the bridge. Date of the most energetic records for each month is given in Table 8-2.

Table 8-2 2023 First three most energetic accelerograms for span 2 of bridge 223 in 2023

Month	Date and time of Most energetic accelerograms		
	1	2	3
January	2023-01-30_07-00	2023-01-31_07-00	2023-01-26_13-00
February	2023-02-01_13-00	2023-02-06_13-00	2023-02-17_13-00
March	2023-03-16_13-00	2023-03-04_13-00	2023-03-08_13-00
April	2023-04-13_08-00	2023-04-24_14-00	2023-04-18_14-00
May	2023-05-23_14-00	2023-05-04_14-00	2023-05-22_08-00
June	2023-06-10_08-00	2023-06-21_08-00	2023-06-13_08-00
July	2023-07-06_14-00	2023-07-07_14-00	2023-07-17_14-00
August	2023-08-07_14-00	2023-08-02_08-00	2023-08-07_20-00
September	2023-09-26_15-00	2023-09-15_11-00	2023-09-27_03-00
October	2023-10-12_09-00	2023-10-26_12-00	2023-10-25_10-00
November	2023-11-06_17-00	2023-11-28_11-00	2023-11-14_10-00
December	2023-12-18_08-00	2023-12-06_10-00	2023-12-28_09-00

Results in terms of identified vibrational frequencies are reported for set 1, set 2, and set 3; respectively in Figure 8-7, Figure 8-8 and Figure 8-9.

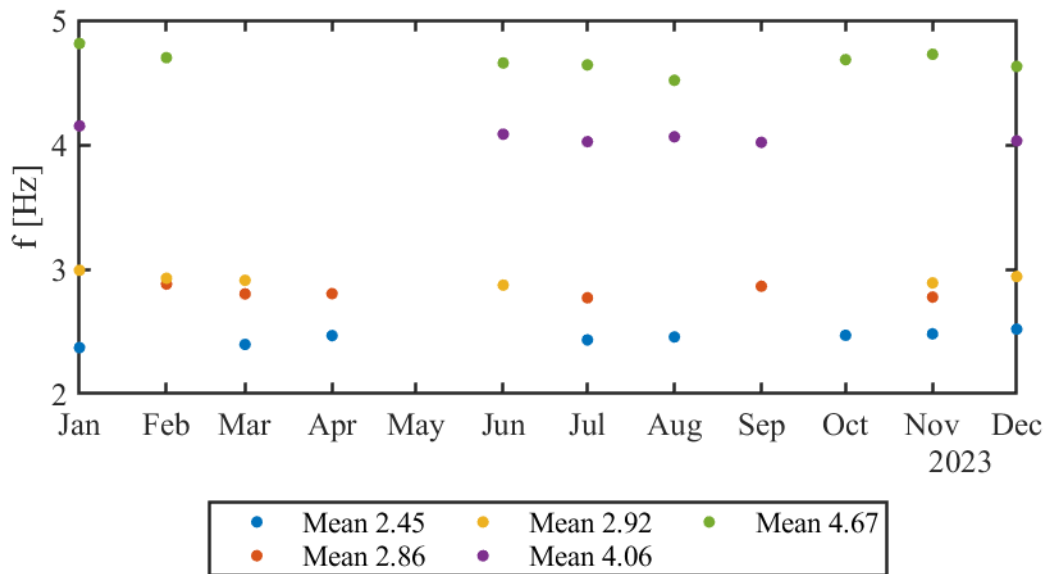

Figure 8-7: 223 deck 2 - Identified frequencies for set 1

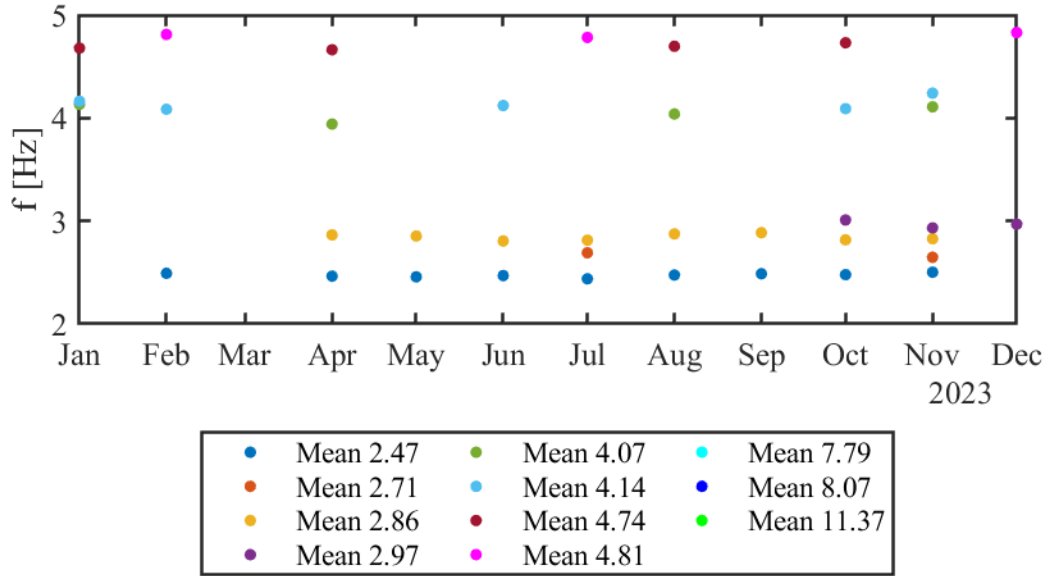

Figure 8-8: 223 deck 2 - Identified frequencies for set 2

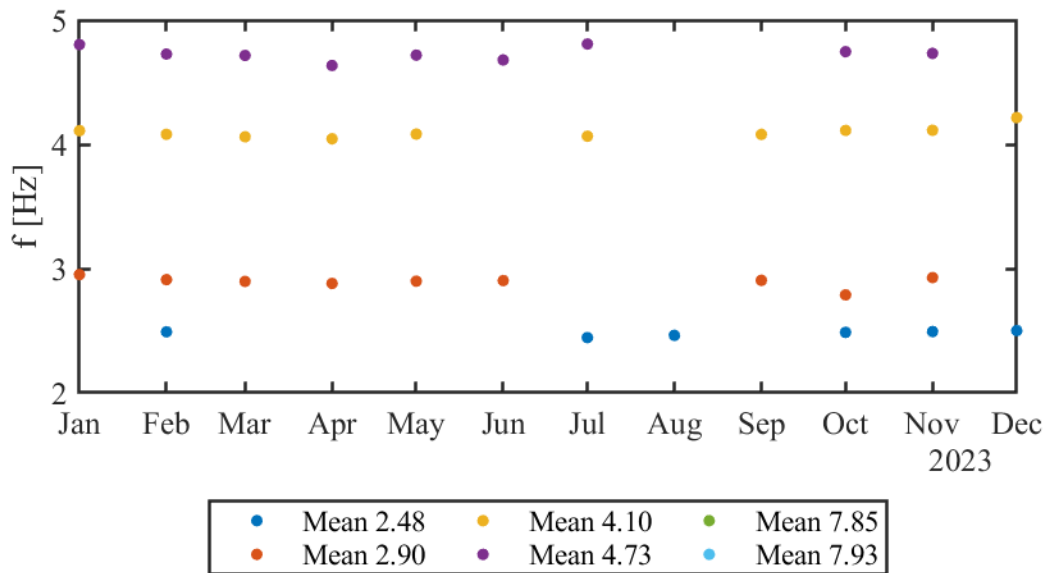

Figure 8-9: 223 deck 2 - Identified frequencies for set 3.

In order to evaluate the most frequently occurring modes that are present in all sets, the three sets are merged and the results are shown in Figure 8-10 and the modal shapes are shown in Figure 8-11.

The most frequent modes are between 2.4 Hz and 4.7 Hz. It is possible to see that some alignments are characterized by very close frequencies and similar modal shapes.

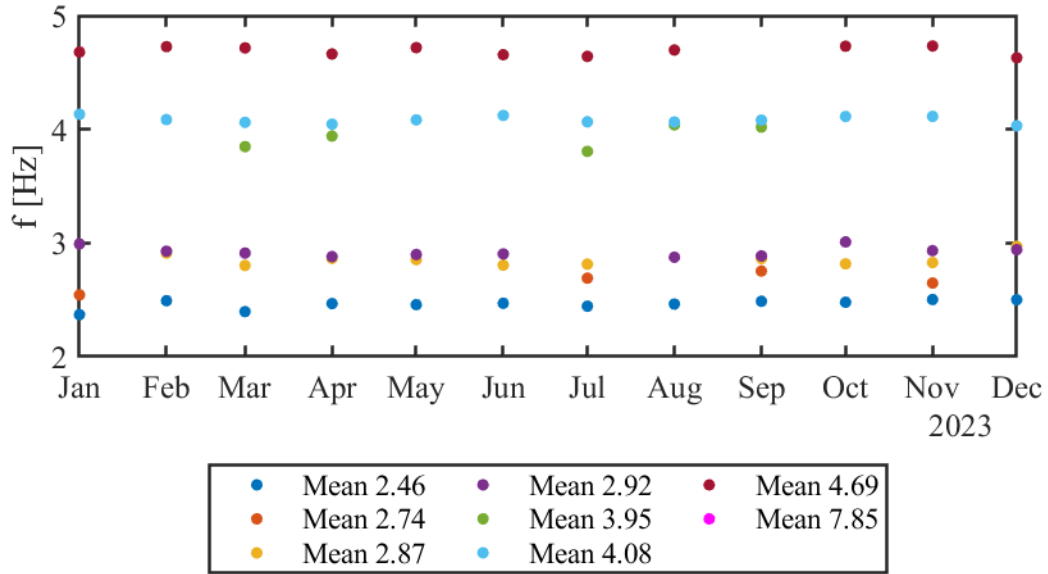
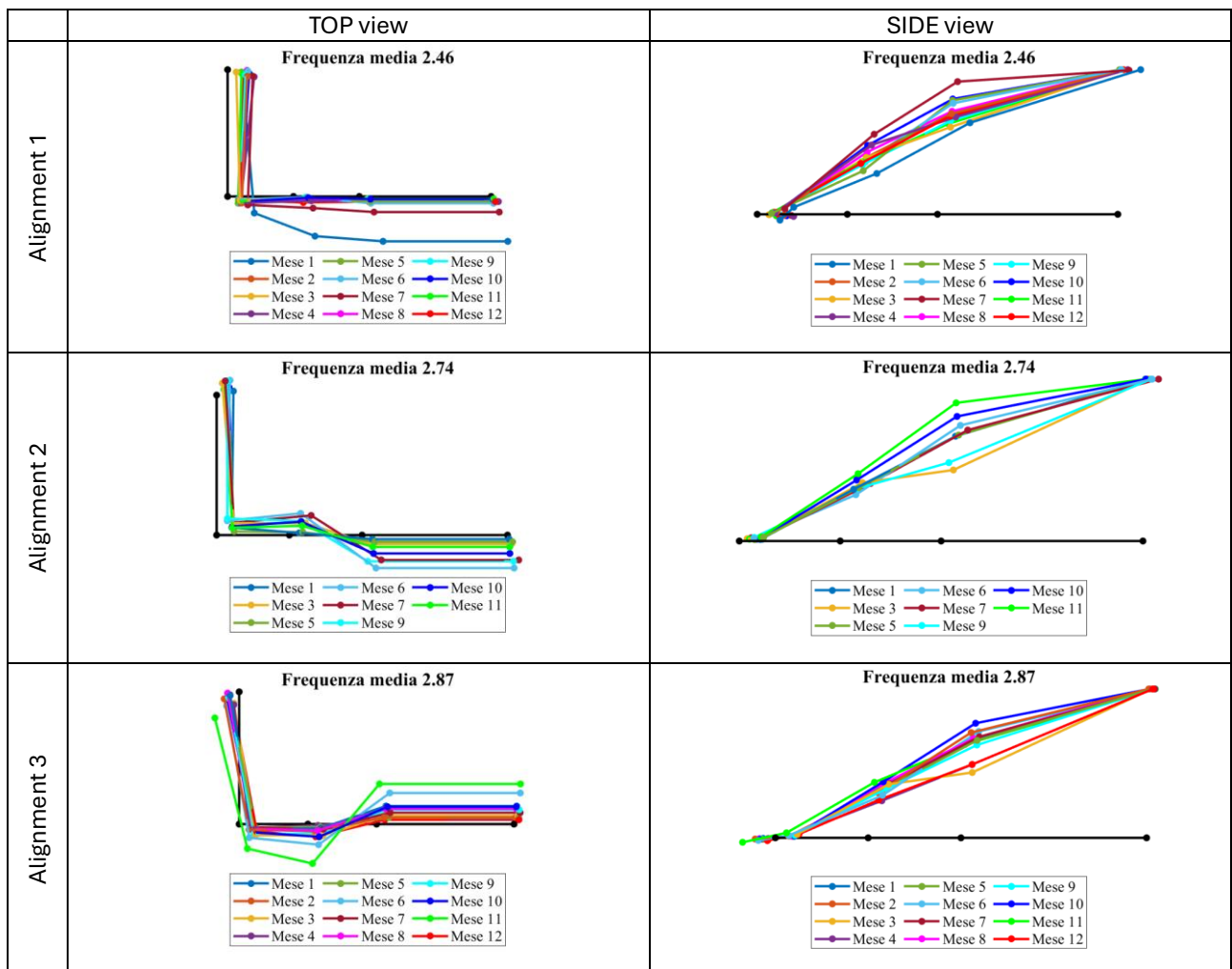

Figure 8-10: 223 deck 2 - Identified frequencies for the merge of the sets.



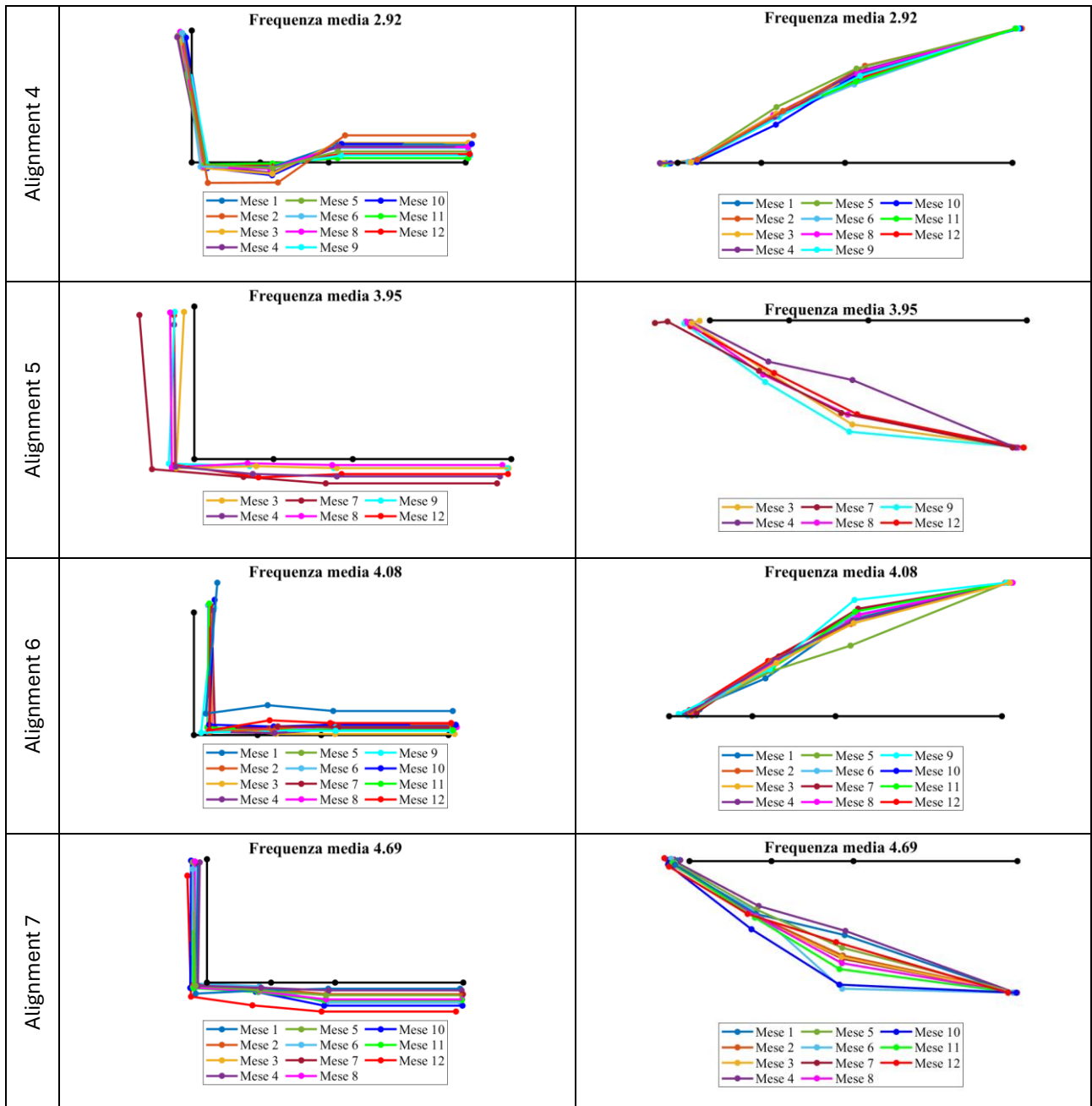

Figure 8-11: 223 deck 2 - Modal shape of the identified modes.

By analyzing the above reported results, it can be deduced that the alignment 5 and 6 have the same modal shape, but they are counterphase. Numerically, two different frequencies have been obtained, but basically they represent the same thing.

Another conclusion which can be made is that the alignment 3 and 4 are the same modal shape, with a slightly different obtained value for the frequency.

8.4 Deck 6 of bridge 223

The identification of modal shapes of deck 6 of bridge 223 is done using the three most overall energetic accelerograms for each month for the span of the bridge. Date of the most energetic records for each month is given in Table 8-3.

Table 8-3 2023 First three most energetic accelerograms for span 6 of bridge 223 in 2023

Month	Date and time of Most energetic accelerograms		
	1	2	3
January	2023-01-30_19-00	2023-01-30_07-00	2023-01-16_13-00
February	2023-02-01_13-00	2023-02-11_13-00	2023-02-06_13-00
March	2023-03-04_13-00	2023-03-16_13-00	2023-03-31_08-00
April	2023-04-13_08-00	2023-04-24_14-00	2023-04-19_08-00
May	2023-05-04_14-00	2023-05-23_14-00	2023-05-31_14-00
June	2023-06-13_08-00	2023-06-20_14-00	2023-06-27_14-00
July	2023-07-07_14-00	2023-07-06_14-00	2023-07-05_20-00
August	2023-08-07_14-00	2023-08-02_08-00	2023-08-03_08-00
September	2023-09-26_09-00	2023-09-26_15-00	2023-09-20_11-00
October	2023-10-12_09-00	2023-10-25_10-00	2023-10-24_10-00
November	2023-11-06_17-00	2023-11-07_17-00	2023-11-28_11-00
December	2023-12-28_09-00	2023-12-18_08-00	2023-12-14_16-00

Results in terms of identified vibrational frequencies are reported for set 1, set 2, and set 3; respectively in Figure 8-12, Figure 8-13 and Figure 8-14.

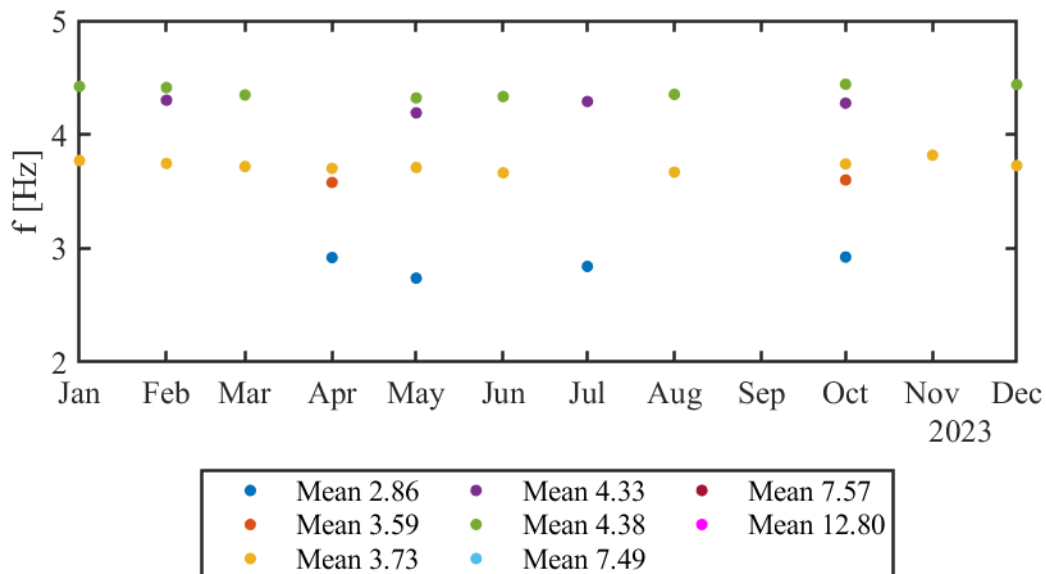

Figure 8-12: 223 deck 6 - Identified frequencies for set 1

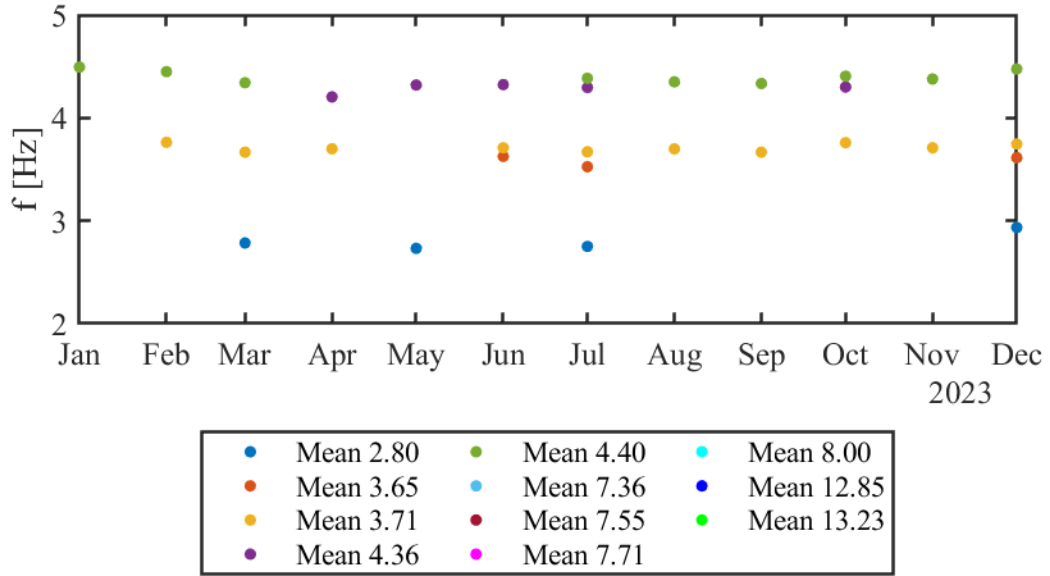

Figure 8-13: 223 deck 6 - Identified frequencies for set 2

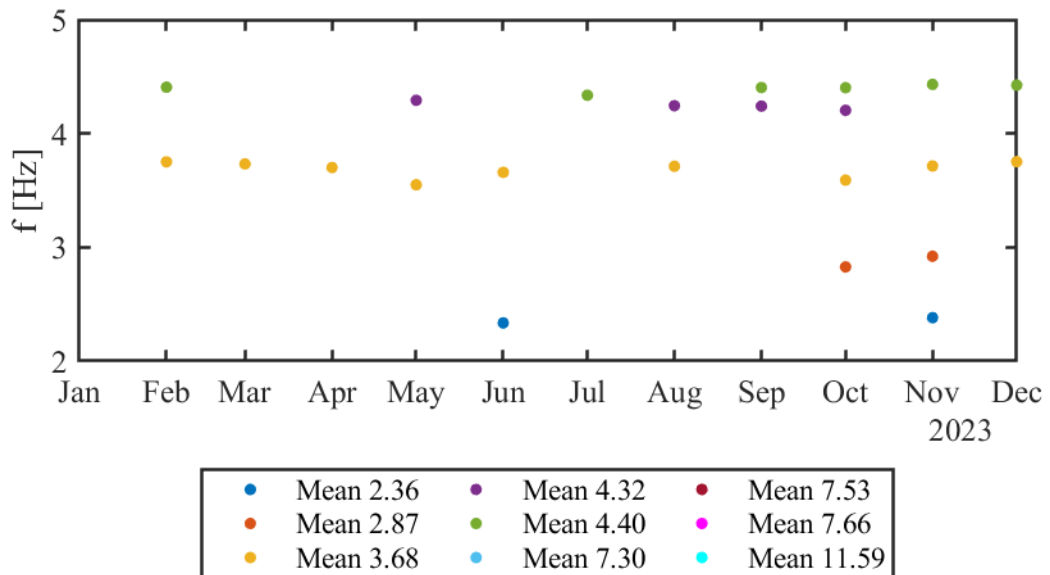

Figure 8-14: 223 deck 6 - Identified frequencies for set 3

In order to evaluate the most frequently occurring modes that are present in all sets, the three sets are merged and the results are shown in Figure 8-15 and the modal shapes are shown in Figure 8-16.

The most frequent modes are between 2.8 Hz and 4.4 Hz. It is possible to see that some alignments are characterized by very close frequencies and similar modal shapes.

Monitoring activity on Fiorenza Node of A4 Highway

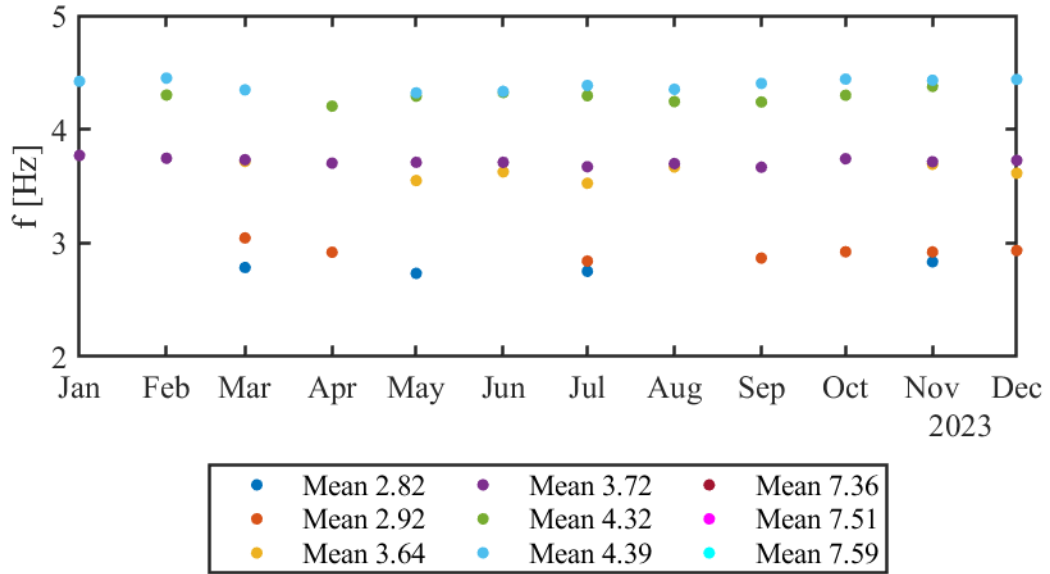
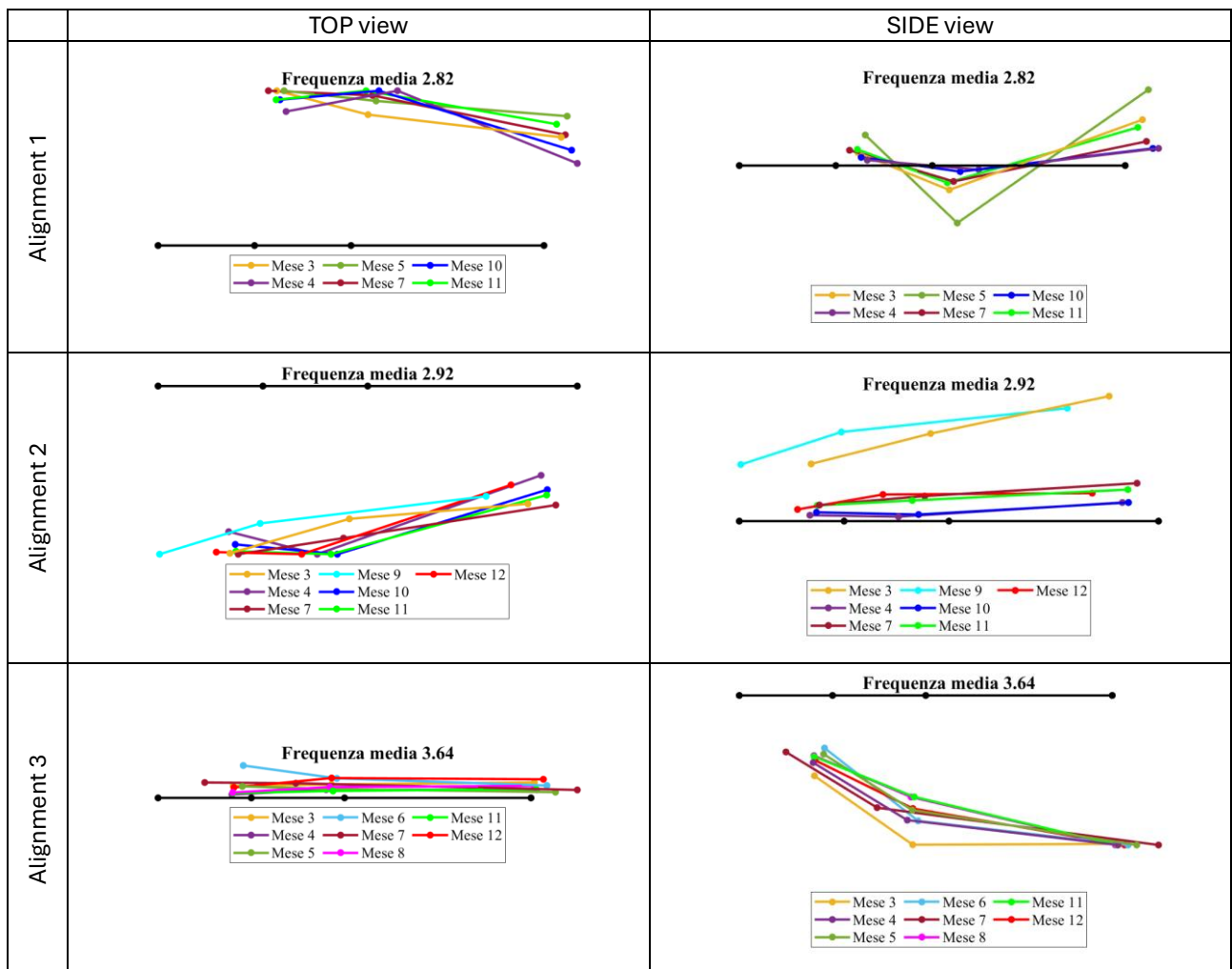

Figure 8-15: 223 deck 6 - Identified frequencies for the merge of the sets



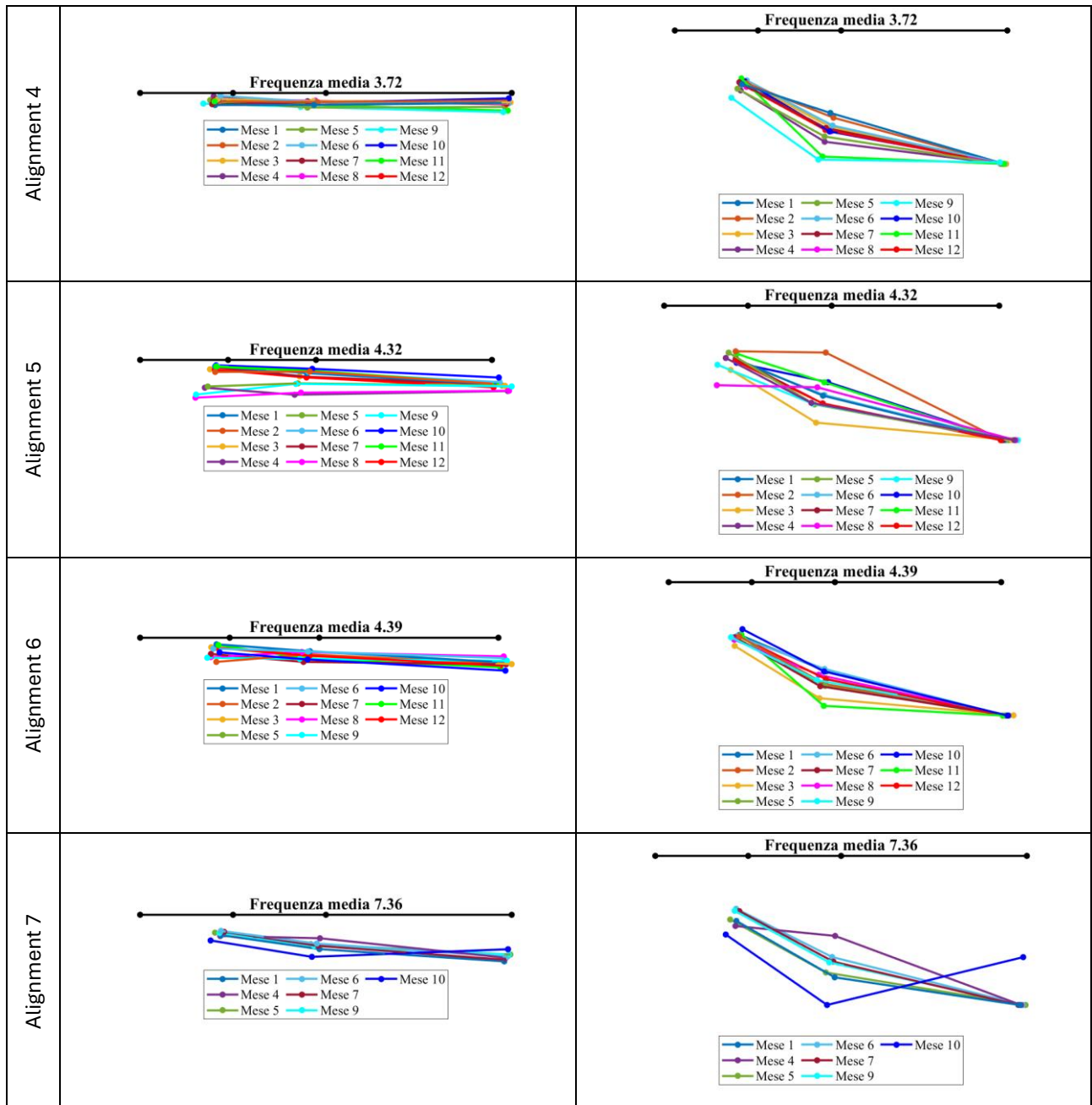

Figure 8-16: 223 deck 6 - Modal shape of the identified modes.

Finally, by analyzing the results obtained for the deck 6 of the 223 bridge, it can be noticed that the alignments 5 and 6 represent the same modal shape, with a slightly different value for the frequency obtained, respectively of 4.32 and 4.39 Hz.

9. Conclusion

Three different type of computation procedure have been made in order to define the proper natural frequencies of the bridges 223 and 2A2: peak-picking procedure from the plots of the power spectral density functions of the most energetic accelerograms; modeling of the structures in SAP2000 and the results obtained by applying the Operational Modal Analysis (OMA) to the most overall energetic accelerograms. This have been done in order to establish if a correlation can be obtained between the three different methods. The obtained results are collected in the Table 9-1.

Table 9-1 2023 Obtained results

		Peak-picking	FEM	OMA
2A2 deck 4 deck 5	1° peak	2.65-2.76	2.48-2.74	-
	2° peak	3.22-3.67	-	-
	3° peak	3.75-4.09	-	3.74-4.14
	4° peak	4.29-4.66	4.39	4.55
<hr/>				
223 deck 2	1° peak	2.23-2.46	2.50	2.46
	2° peak	2.80-2.89	2.68	2.74-2.92
	3° peak	3.90-4.06	-	3.95-4.08
	4° peak	4.64-4.73	4.73	4.69
<hr/>				
223 deck 6	1° peak	-	-	-
	2° peak	2.89-2.96	2.68	2.82-2.92
	3° peak	3.71	-	3.64-3.72
	4° peak	4.36-4.37	4.40	4.32-4.39

For the bridge 2A2, a correlation between the results obtained with the FEM and the OMA has been defined for the 4th peak. The mode shapes identified for this peak are reported from Figure 9-1 to Figure 9-3.

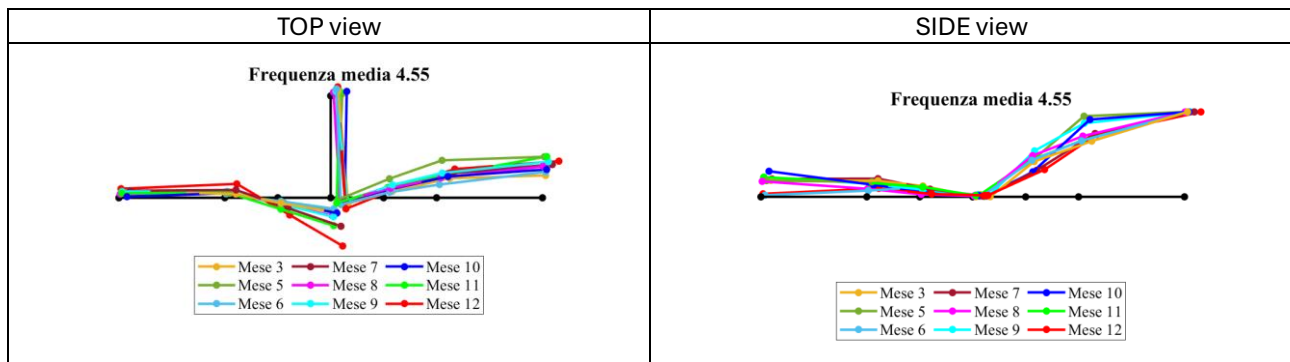

Figure 9-1: 2A2 deck 4 and deck 5 - Modal shape identified with the OMA – Top and Side view.

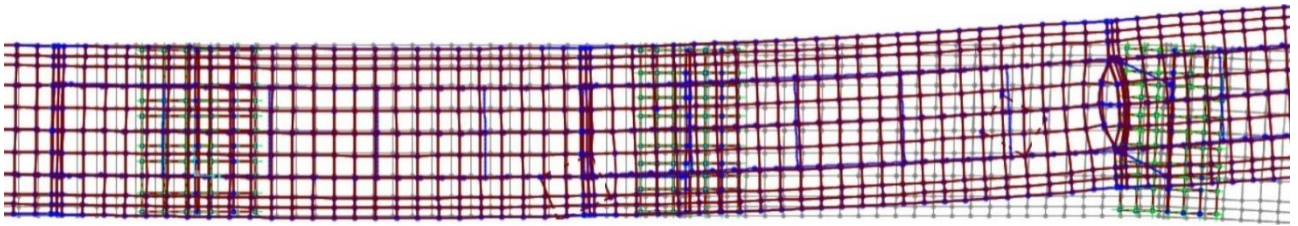

Figure 9-2: 2A2 deck 4 and deck 5 - Modal shape identified with the FEA – Top view – 4.39Hz.

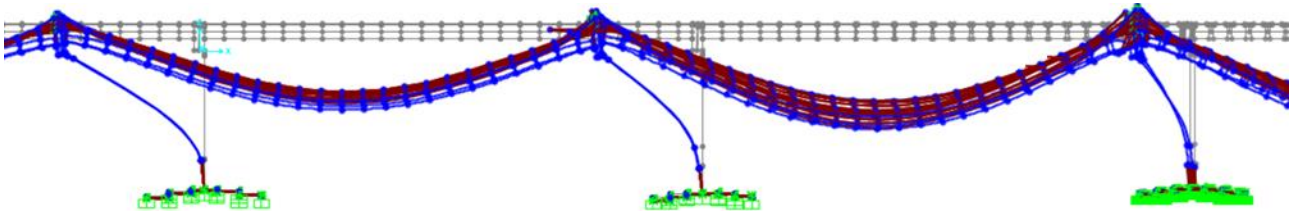

Figure 9-3: 2A2 deck 4 and deck 5 - Modal shape identified with the FEA – Side view – 4.39Hz.

For the deck 2 of the bridge 223, a conformity between the 1st, the 2nd and 4th peak has been defined. The mode shapes obtained with the FEA and the OMA are reported from Figure 9-4 to Figure 9-12.

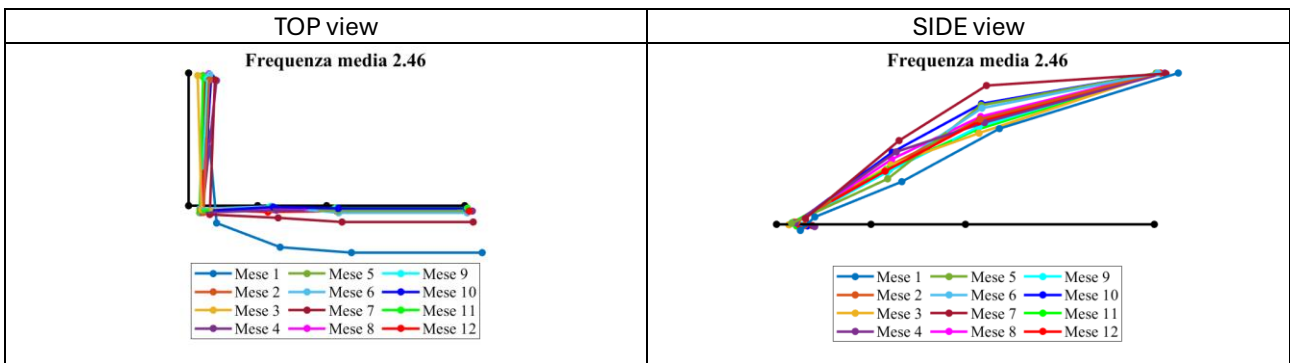

Figure 9-4: 223 deck 2 - Modal shape identified with the OMA – Top and Side view.

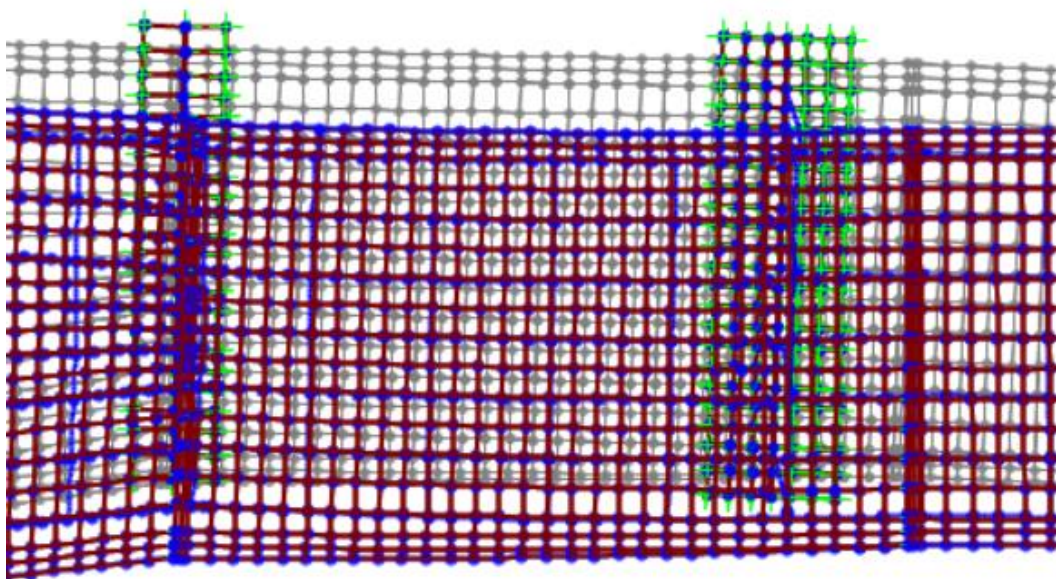

Figure 9-5: 223 deck 2 - Modal shape identified with the FEA – Top view – 2.50Hz.

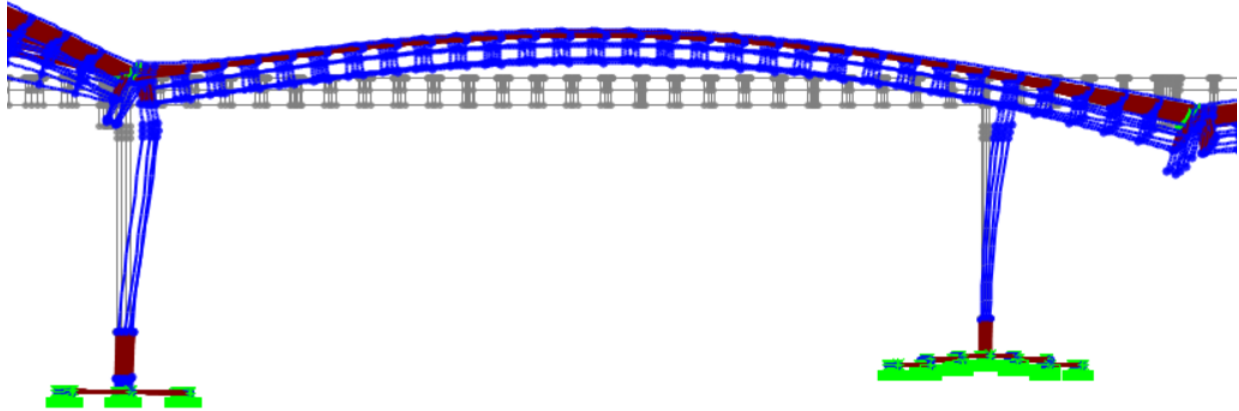

Figure 9-6: 223 deck 2 - Modal shape identified with the FEA – side view – 2.50Hz.

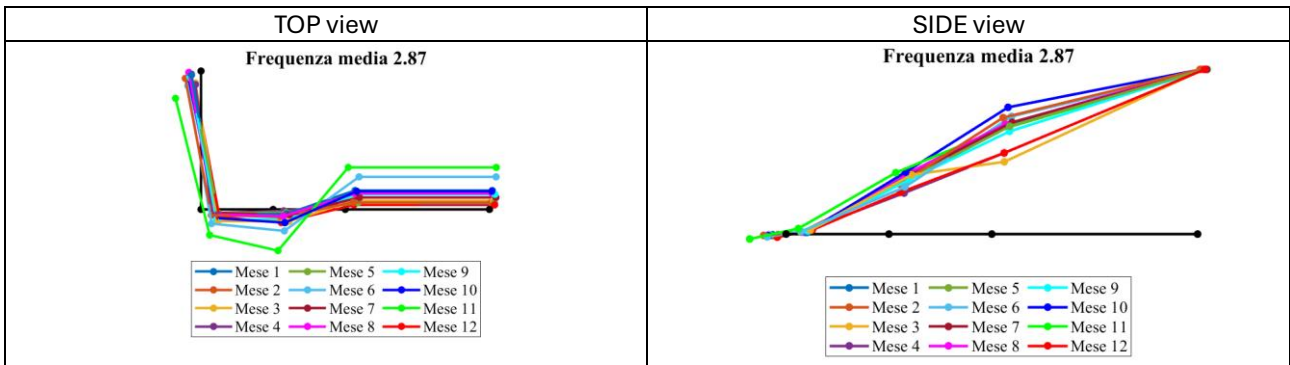

Figure 9-7: 223 deck 2 - Modal shape identified with the OMA – Top and Side view.

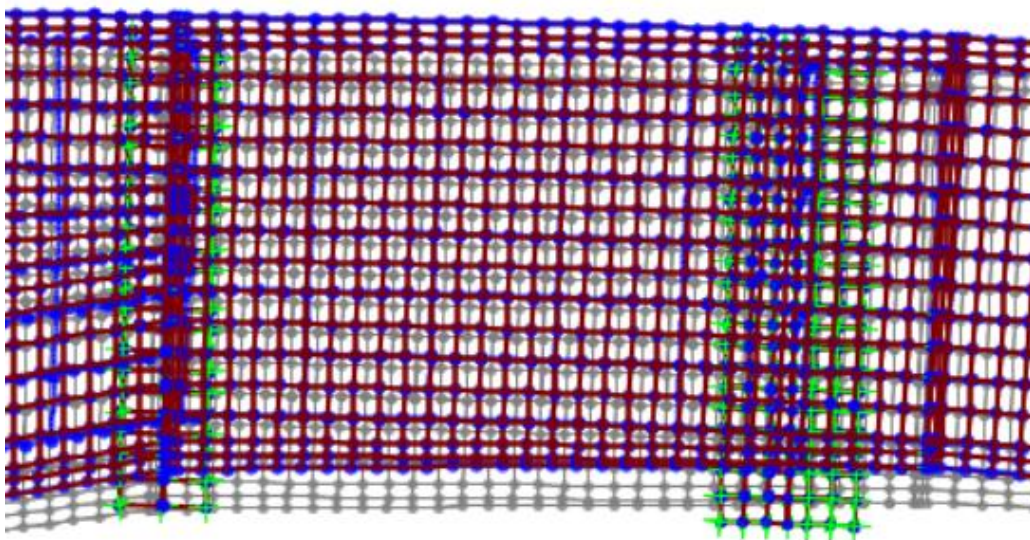

Figure 9-8: 223 deck 2 - Modal shape identified with the FEA – Top view – 2.68Hz.

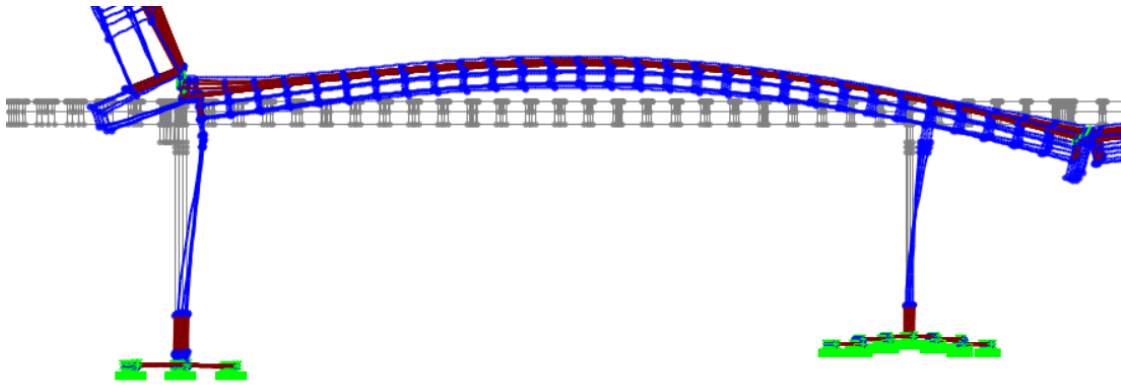

Figure 9-9: 223 deck 2 - Modal shape identified with the FEA – Side view – 2.68Hz.

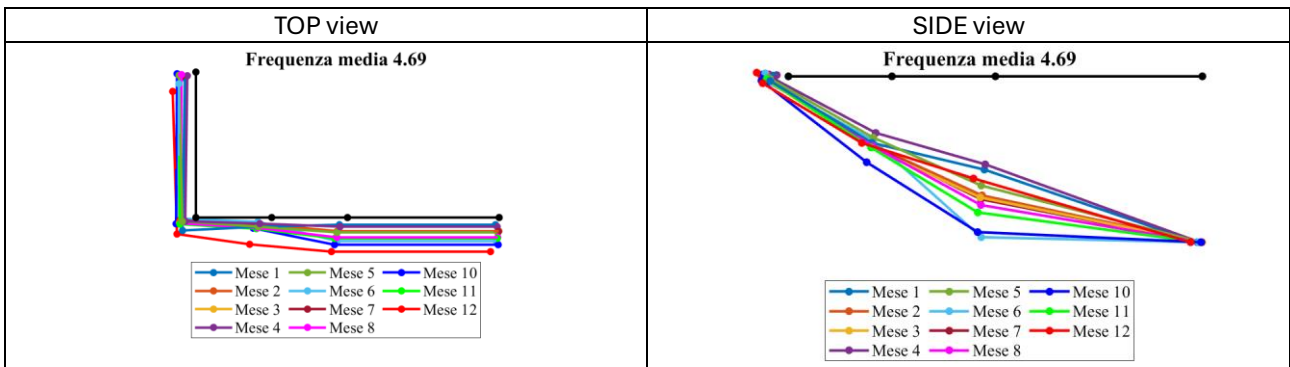

Figure 9-10: 223 deck 2 - Modal shape identified with the OMA – Top and Side view.

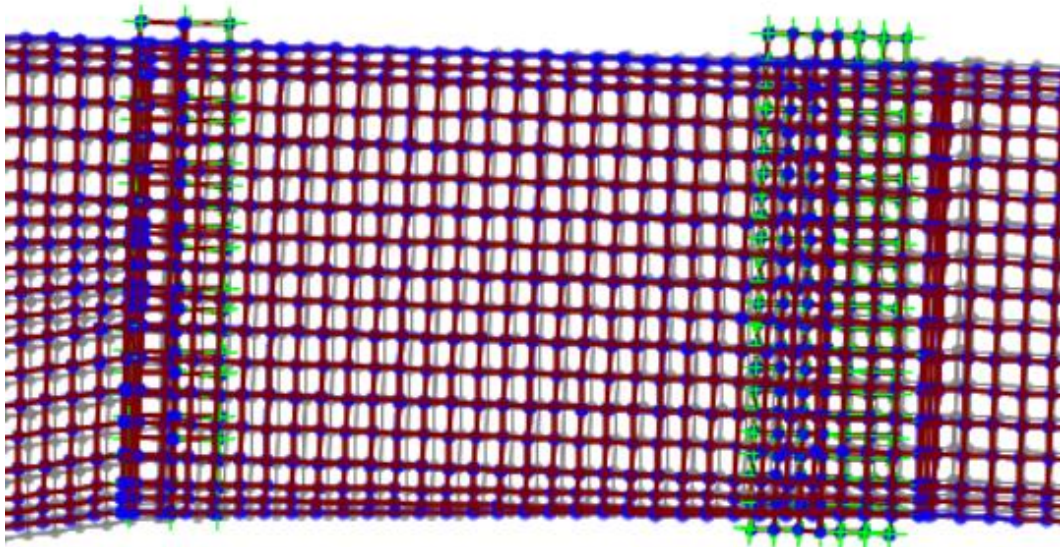

Figure 9-11: 223 deck 2 - Modal shape identified with the FEA – Top view – 4.73Hz.

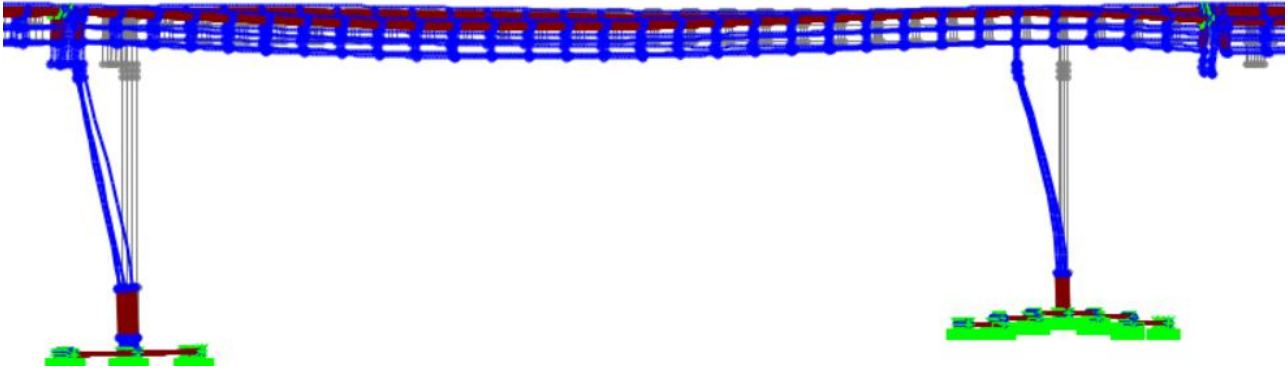

Figure 9-12: 223 deck 2 - Modal shape identified with the FEA – Side view – 4.73Hz.

Finally, for the deck 6 of the bridge 223, a conformity between 2nd and 4th peak has been defined. The mode shapes obtained with the FEA and the OMA are reported from the Figure 9-13 to Figure 9-18.

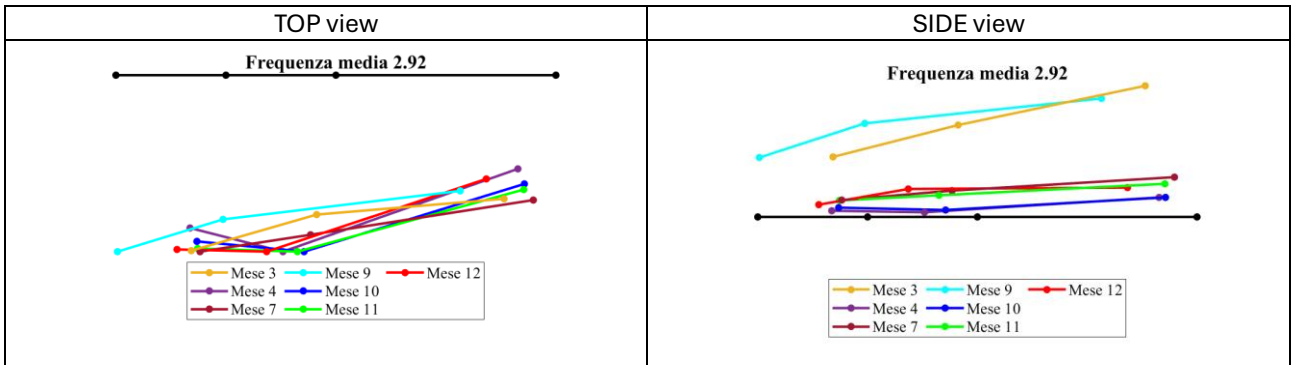

Figure 9-13: 223 deck 6 - Modal shape identified with the OMA – Top and Side view.

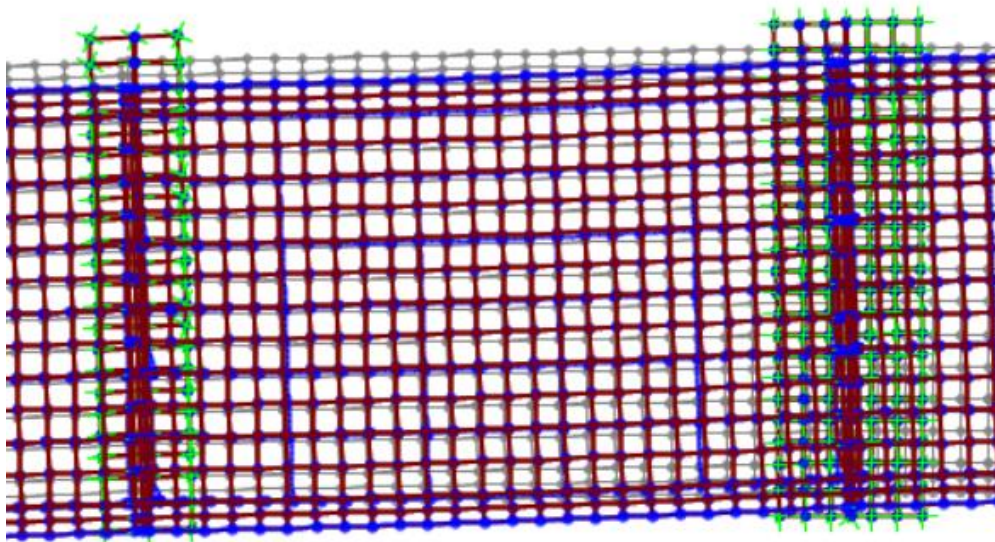

Figure 9-14: 223 deck 6 - Modal shape identified with the FEA – Top view – 2.68Hz.

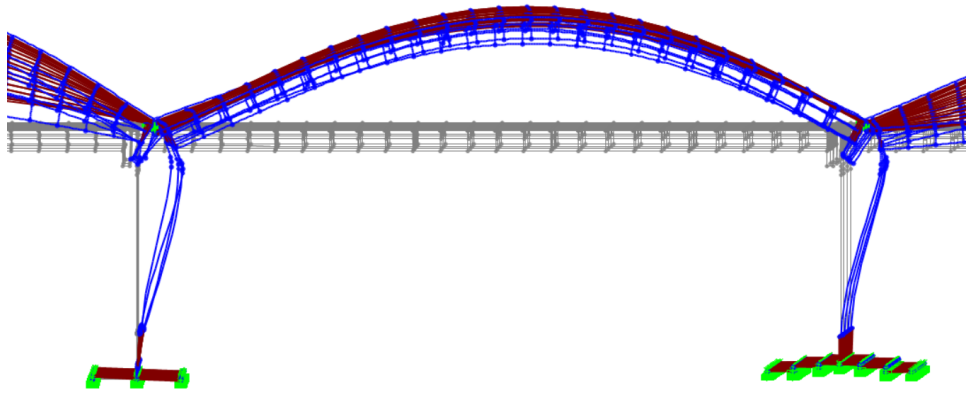

Figure 9-15: 223 deck 6 - Modal shape identified with the FEA – Side view – 2.68Hz.

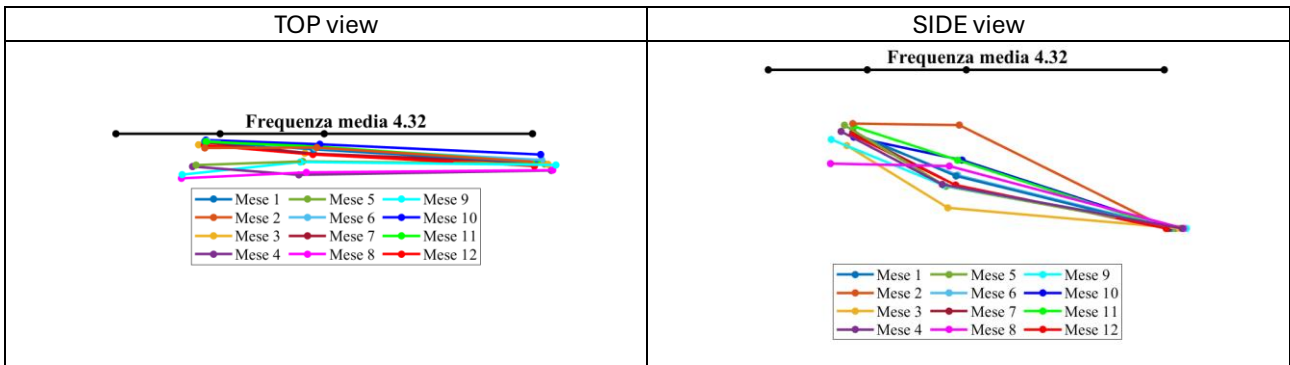

Figure 9-16: 223 deck 6 - Modal shape identified with the OMA – Top and Side view.

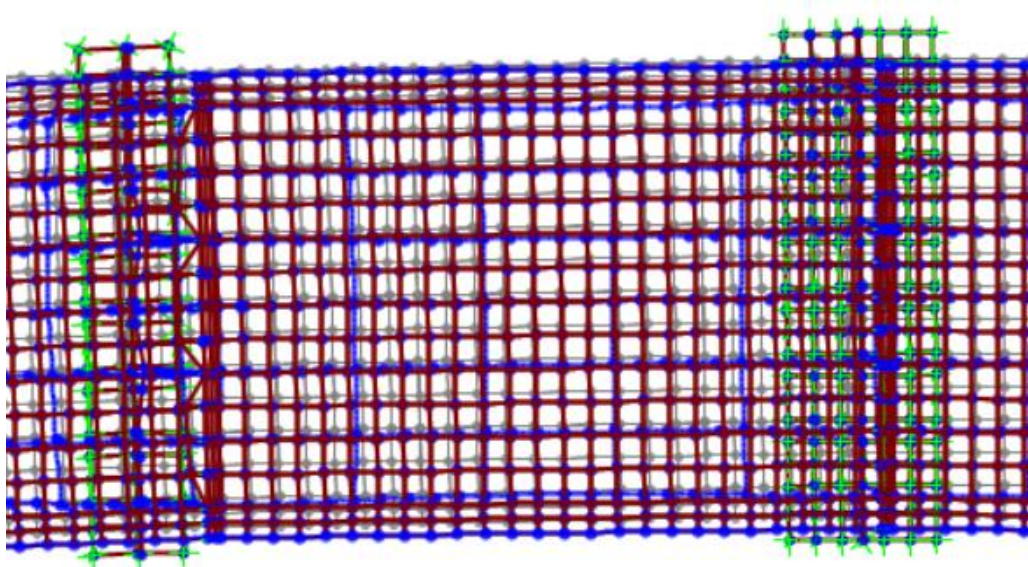

Figure 9-17: 223 deck 6 - Modal shape identified with the FEA – Top view – 4.40Hz.

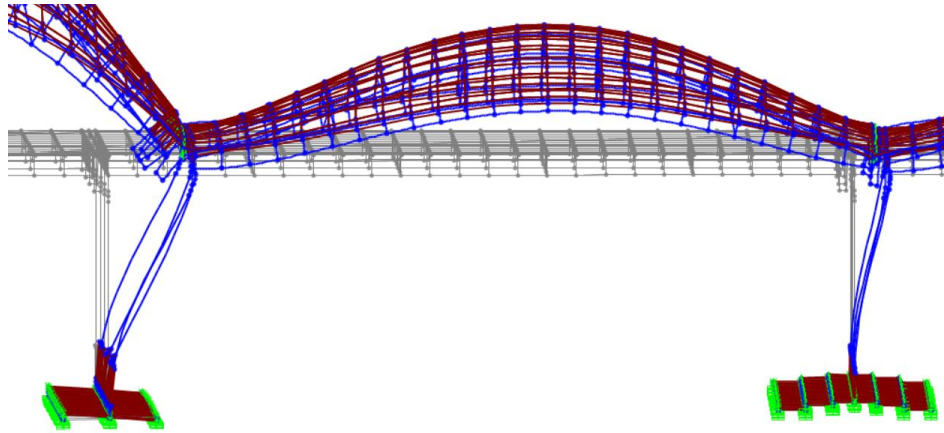

Figure 9-18: 223 deck 6 - Modal shape identified with the FEA – Side view – 4.40Hz.

Like can be seen from the Table 9-1, the results obtained with the Peak-picking method and the Operational Modal Analysis (OMA) are almost the same, while the results obtained from the FEM are a little bit different, especially the third peak identified with the peak-picking method and the OMA is missing in the FEA. This can be the consequence of the unknown of the complete project of the bridge, like in this case, where the model has been made by analyzing the original projects and reports which are date back to 1960s.

Finally, another conclusion which can be made is that the identified frequencies are constant during the entire year and every structure is characterized by the same range of frequencies. This peculiarity helped in the identification of a crack present in one pile of the 223 bridge, for which one an anomalous low frequency has been identified.

Bibliography

- [1] Carlo Rainieri and Giovanni Fabbrocino. “Operational Modal Analysis of Civil Engineering Structures”.
- [2] Computers & Structures, INC. “SAP 2000 – Integrated Solution for Structural Analysis and Design”.
- [3] Computers & Structures, INC. “SAP 2000 – Bridge Examples”.
- [4] Autostrade – Concessioni e costruzioni Autostrade S.p.A., “Lavori di costruzione del lotto N°6 – Viadotto Milano-Torino - Impalcato”
- [5] Costruzioni Metalliche Finsider S.p.A., “Autostrada Milano-Torino Svincolo di Firenze – Strutture metalliche dell’impalcato”, 25/10/1963
- [6] Autostrade – Concessioni e costruzioni Autostrade S.p.A., “Lavori di costruzione del lotto N°6 – Viadotto Milano-Torino – Spalla lato Torino – Armatura e Murature – Pile e plinti”
- [7] Autostrade – Concessioni e costruzioni Autostrade S.p.A., “Lavori di costruzione del lotto N°6 – Viadotto Milano-Torino – Disegno nr.5”
- [8] Autostrade – Concessioni e costruzioni Autostrade S.p.A., “Lavori di costruzione del lotto N°6 – Viadotto Milano-Torino – Disegno nr.29401/5”, 15/03/1994
- [9] Autostrade per l’Italia, “Cav. Carr. Dx A/8 – Ex viadotto Milano Laghi”
- [10] Autostrade per l’Italia, “Progetto esecutivo – Svincolo Firenze – Cavalcavia 2 – N° elaborato R-004”
- [11] Autostrade per l’Italia, “Svincoli di Firenze – Viadotto S.S. Varesina – Disegno N°8”
- [12] Autostrade – Concessioni e costruzioni Autostrade S.p.A., “Lavori di costruzione del lotto N°6 – Viadotto Milano-Laghi – Disegno nr.5”
- [13] Autostrade – Concessioni e costruzioni Autostrade S.p.A., “Lavori di costruzione del lotto N°6 – Viadotto Milano-Laghi – Spalla lato Torino – Armatura e Murature”
- [14] Autostrade – Concessioni e costruzioni Autostrade S.p.A., “Lavori di costruzione del lotto N°6 – Viadotto Milano-Laghi – Armatura e Murature delle Pile – Disegno N°4”
- [15] Autostrade per l’Italia, “Cav. SS233 Varesina – Ex viadotto S.S. Varesina”
- [16] Autostrade per l’Italia, “Svincolo Firenze – Stralcio 41760/D”, 11/12/1963
- [17] Autostrade – Concessioni e costruzioni Autostrade S.p.A., “Lavori di costruzione del lotto N°6 – Viadotto S.S. Varesina – Impalcato”
- [18] Autostrade per l’Italia, “Cav. SV. Innesso SS233 Varesina”
- [19] Autostrade – Concessioni e costruzioni Autostrade S.p.A., “Svincoli di Firenze – Viadotto Torino-Bergamo”
- [20] IMI Intelligent Monitoring, “Pianta e Sezioni Impalcato – Opera 0002A2 – Elaborato N°2”, Giugno 2022
- [21] IMI Intelligent Monitoring, “Pianta e Sezioni Impalcato – Opera 0002A2 – Elaborato N°3”, Giugno 2022

Acknowledgements

First, I would like to thank the professor Gabriele Bertagnoli, which one furnished to me all the material and all the knowledges needed for the completion of this master thesis. He gives to me all the support and all the necessary advices which helped me to finish this work. I would like to extend my gratitude also to the Engineer Mario Ferrara, which one with his ideas and the technical support helped me to solve every problem.

I want to show my appreciation to my friends, peoples which I met during my bachelor's and my master's degree, thanks to who all the moments passed merrily. Especially to Valeria and Fatiha, which ones became an example for me during this period, so I always tried to don't lose sight of these persons, this is why I will always be grateful to them.

I would like also to express my gratitude to all the teachers which I met during my entire educational career; they all have been contributed to the person which I had become.

A special acknowledgement is for my family. Without their effort, I wouldn't be here, and I couldn't reach this goal. A particular characteristic for which I'm grateful to them, is the faith which they give to me. This permit to grow up and to become a better person.

Lastly, I would like to express my deep gratitude to Giulia: my "little monkey" which came in my life 6 years ago. Thanks to her, the sad and bad moments disappeared. Her levity and state of mind helped me to overcome every thought which pushed me down.

Annex 13

The Bridge 223 counts 2 monitored decks: span 2 and span 6 (see Figure 0-1).

On each deck, 4 sensors are present: one in the midspan ($L/2$), one at $L/4$ of the span, one at $L/8$ of the span and the last one near the pier.

The sensors present on deck number 2 are:

- 2BE0F – situated in the midspan;
- 2BA63 – situated at a distance of $L/4$;
- 31205 – situated at a distance of $L/8$;
- 319BC – situated nearby the west pier;
- 319E3 – situated nearby the east pier.

The sensors present on deck number 6 are:

- 2B5E7 – situated in the midspan;
- 2BCF9 – situated at a distance of $L/4$ of the deck;
- 2BCAD – situated at a distance of $L/8$ of the deck;

Monitored deck

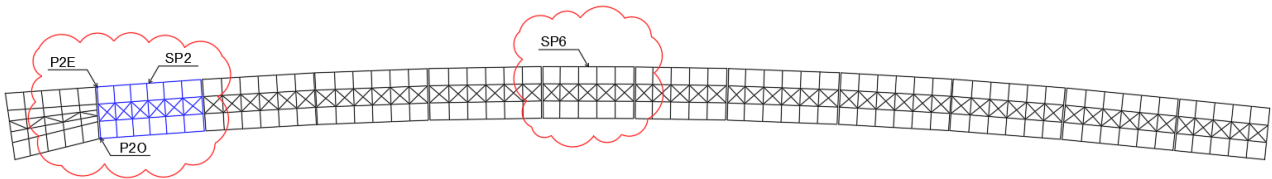

Figure 0-1 Monitored decks of 223 bridge

The accelerograms of the 319E3 sensor have been analyzed and the results are represented in the following paragraphs.

10.1 January

The results obtained for the January dataset are shown in the following tables.

Table 0-1: January 2023 - Accelerograms with the maximum standard deviation

	#	Accelerogram	Standard deviation
Vertical direction (x)	1°	319E3_2023-01-24_01-00-20	8.76E-05
	2°	319E3_2023-01-27_01-00-20	8.52E-05
	3°	319E3_2023-01-26_13-00-20	7.85E-05
Longitudinal direction (y)	1°	319E3_2023-01-30_07-00-21	5.86E-04
	2°	319E3_2023-01-26_13-00-20	5.59E-04
	3°	319E3_2023-01-31_07-00-21	5.41E-04
Transverse direction (z)	1°	319E3_2023-01-24_01-00-20	5.67E-04
	2°	319E3_2023-01-27_01-00-20	4.34E-04
	3°	319E3_2023-01-16_13-00-20	4.12E-04

Table 0-2: January 2023 - Accelerograms defined by the maximum area and peak of the power spectral density function

Vertical direction (x)				
#	Accelerogram	Peak value	Accelerogram	Area
1	319E3_2023-01-31_07-00-21	5.58E-09	319E3_2023-01-24_01-00-20	1.73E-09
2	319E3_2023-01-24_01-00-20	5.29E-09	319E3_2023-01-26_13-00-20	1.30E-09
3	319E3_2023-01-26_13-00-20	5.16E-09	319E3_2023-01-27_01-00-20	1.29E-09
Longitudinal direction (y)				
	Accelerogram	Peak value	Accelerogram	Area
1	319E3_2023-01-30_07-00-21	4.18E-07	319E3_2023-01-30_07-00-21	6.92E-08
2	319E3_2023-01-31_07-00-21	3.30E-07	319E3_2023-01-26_13-00-20	6.60E-08
3	319E3_2023-01-26_13-00-20	3.29E-07	319E3_2023-01-27_01-00-20	6.01E-08
Transverse direction (z)				
	Accelerogram	Peak value	Accelerogram	Area
1	319E3_2023-01-24_01-00-20	2.57E-07	319E3_2023-01-24_01-00-20	7.30E-08
2	319E3_2023-01-27_01-00-20	1.61E-07	319E3_2023-01-25_07-00-21	3.81E-08
3	319E3_2023-01-26_07-00-21	1.58E-07	319E3_2023-01-27_01-00-20	3.67E-08

Table 0-3: January 2023 – Statistical analysis

	Vertical X			Longitudinal Y			Transverse Z		
	Std	Peak	Area	Std	Peak	Area	Std	Peak	Area
1	A	-	A	D	D	D	A	A	A
2	B	A	C	C	E	C	B	B	-
3	C	C	B	E	C	-	-	-	B

10.1.1 Vertical direction (x)

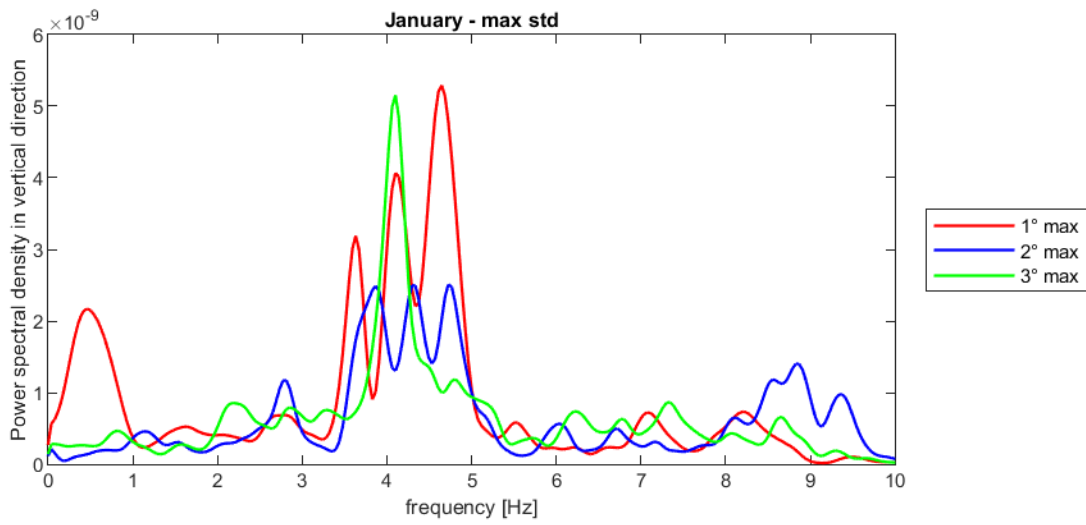

Figure 0-2: Results obtained from the 3 accelerograms with maximum SD in time domain

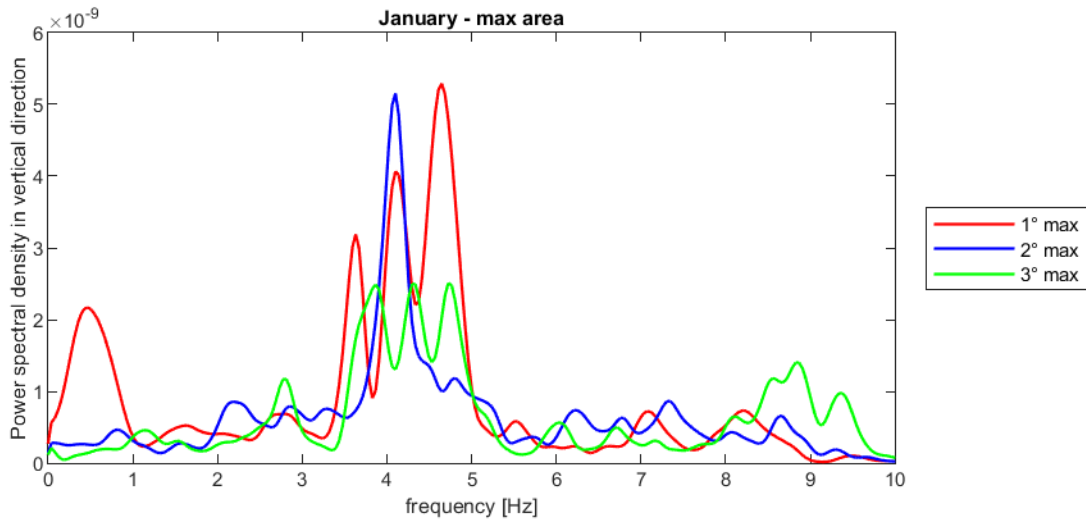

Figure 0-3: Results obtained from the 3 accelerograms with maximum area of PSD

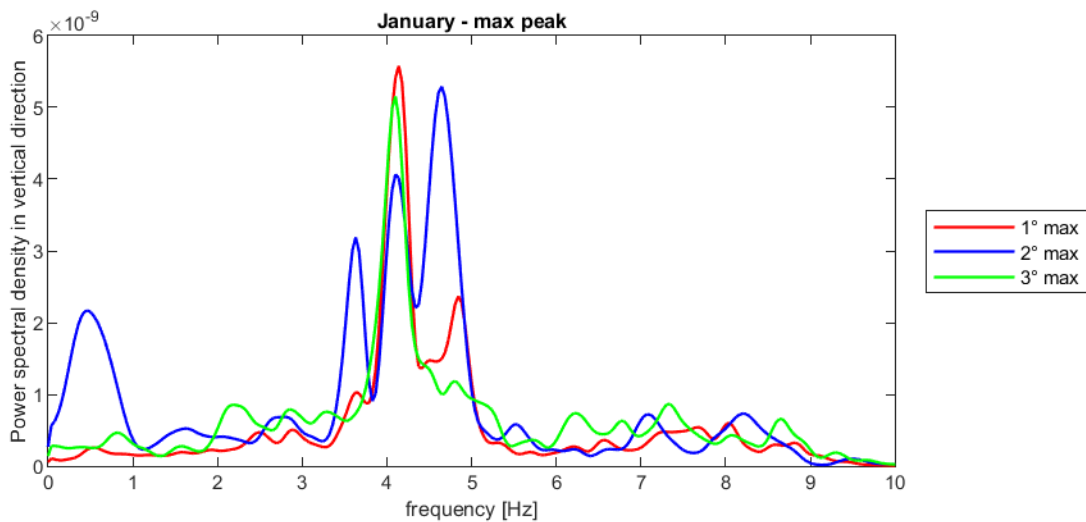

Figure 0-4: Results obtained from the 3 accelerograms with highest peak if PSD

Monitoring activity on Fiorenza Node of A4 Highway

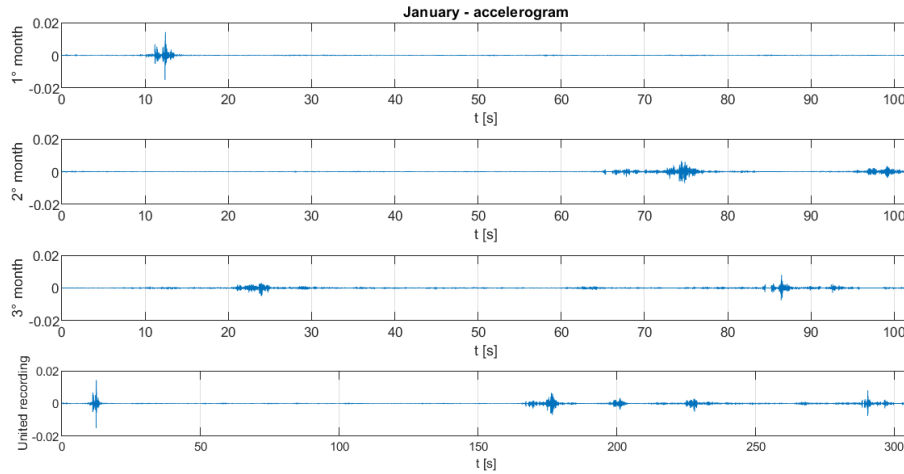

Figure 0-5: Accelerograms in vertical (x) direction with maximum standard deviation in time domain

10.1.2 Longitudinal direction (y)

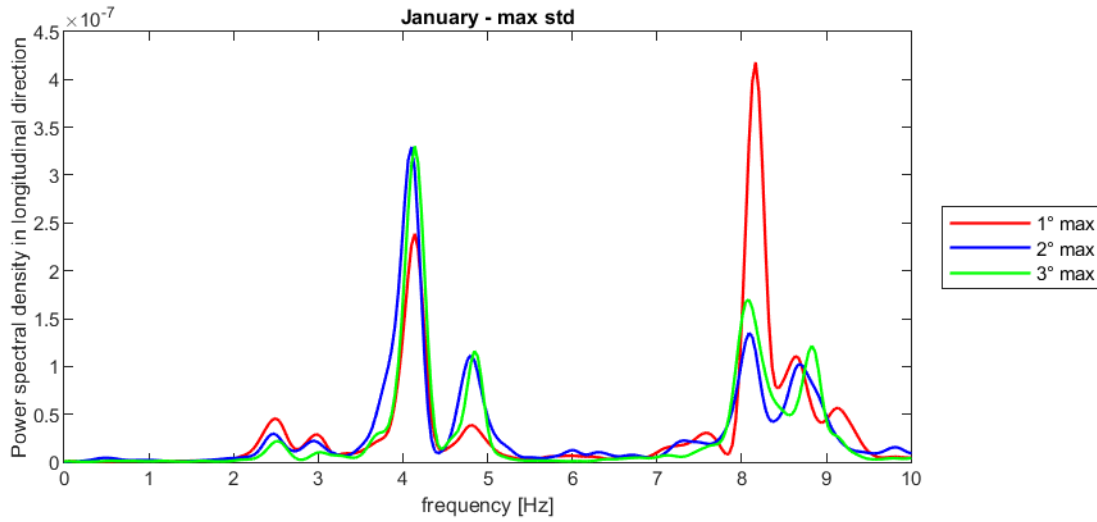

Figure 0-6: Results obtained from the 3 accelerograms with maximum SD in time domain

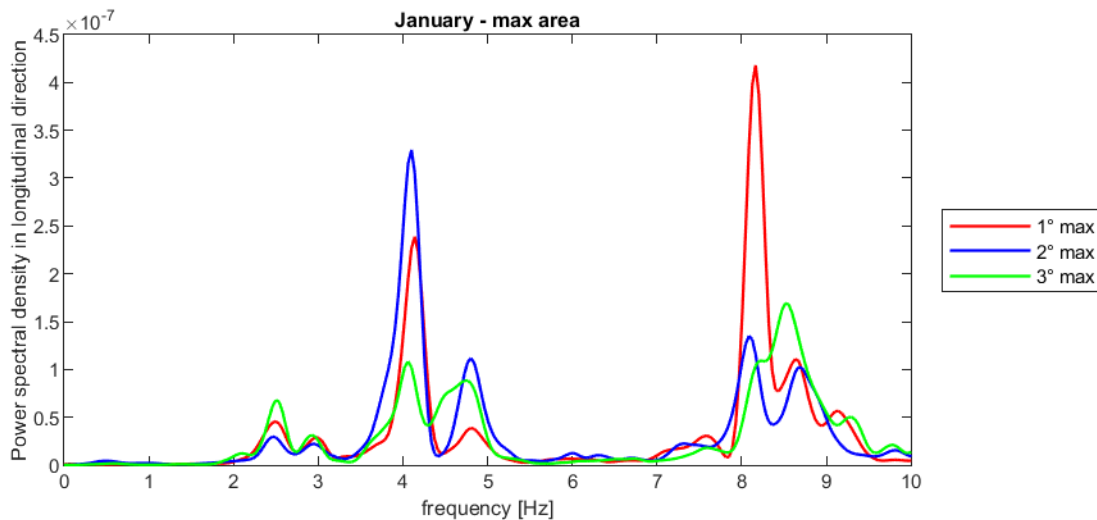

Figure 0-7: Results obtained from the 3 accelerograms with maximum area of PSD

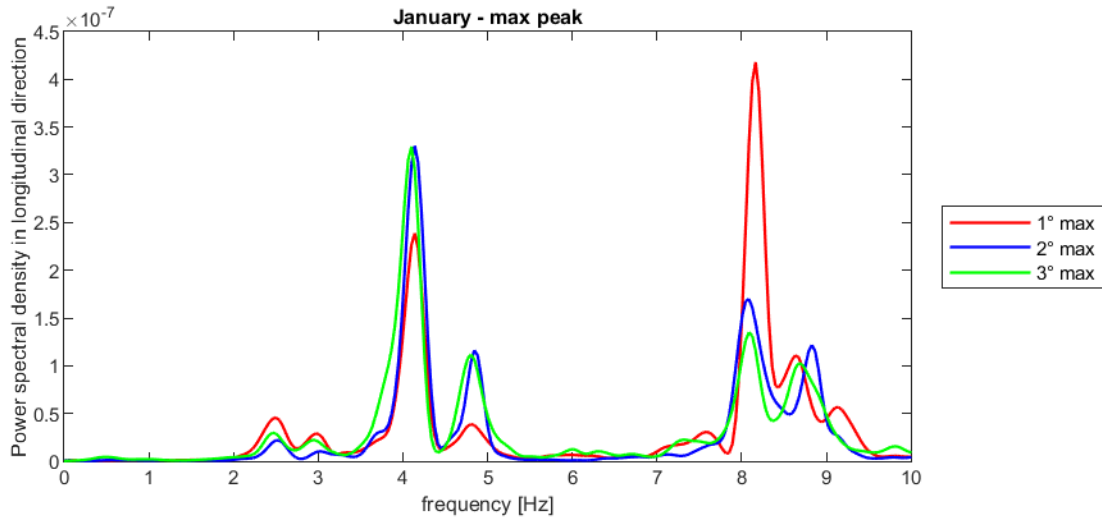

Figure 0-8: Results obtained from the 3 accelerograms with highest peak in PSD

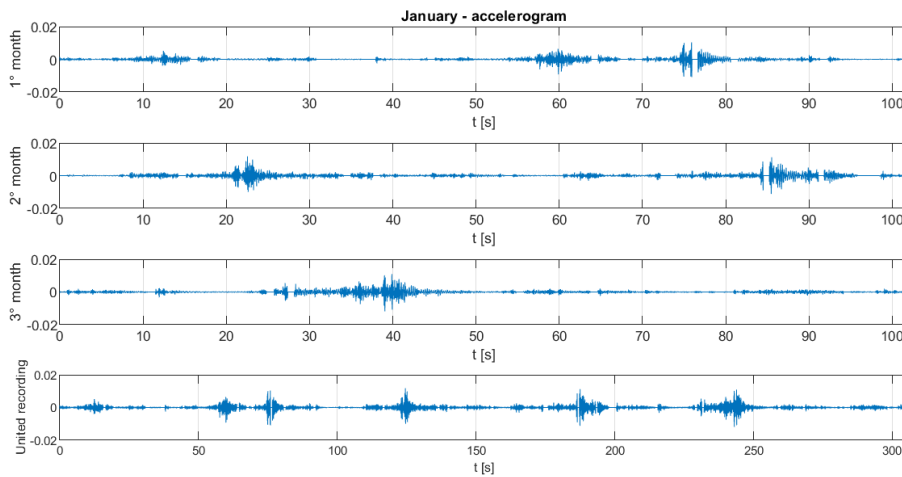

Figure 0-9: Accelerograms in longitudinal (y) direction with maximum standard deviation in time domain

10.1.3 Transverse direction (z)

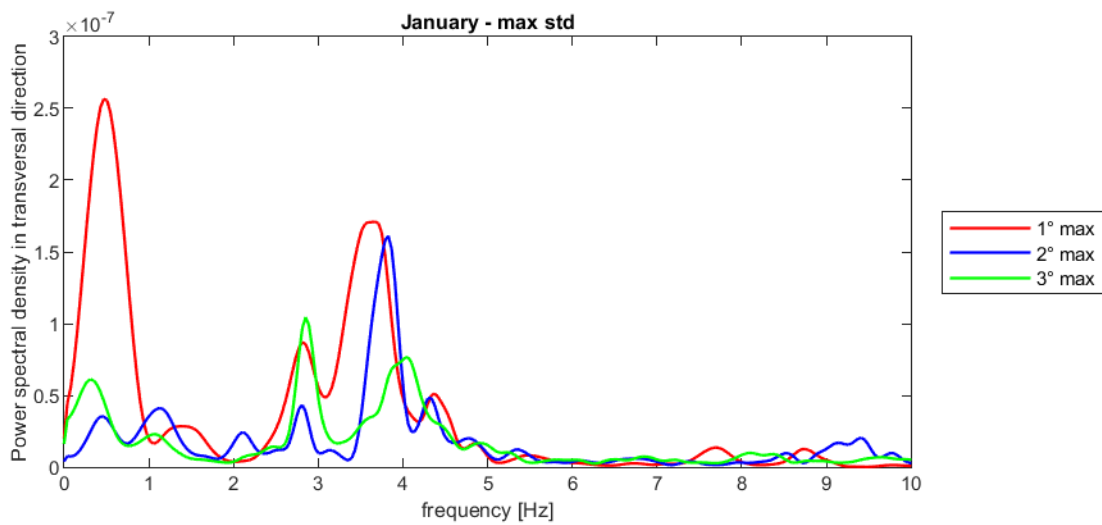

Figure 0-10: Results obtained from the 3 accelerograms with maximum SD in time domain

Monitoring activity on Fiorenza Node of A4 Highway

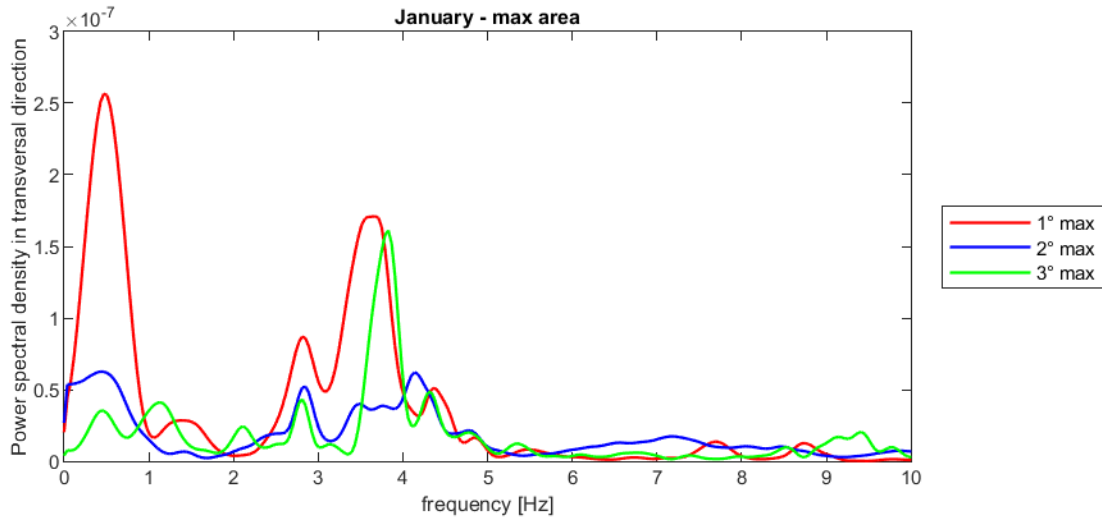

Figure 0-11: Results obtained from the 3 accelerograms with maximum area of PSD

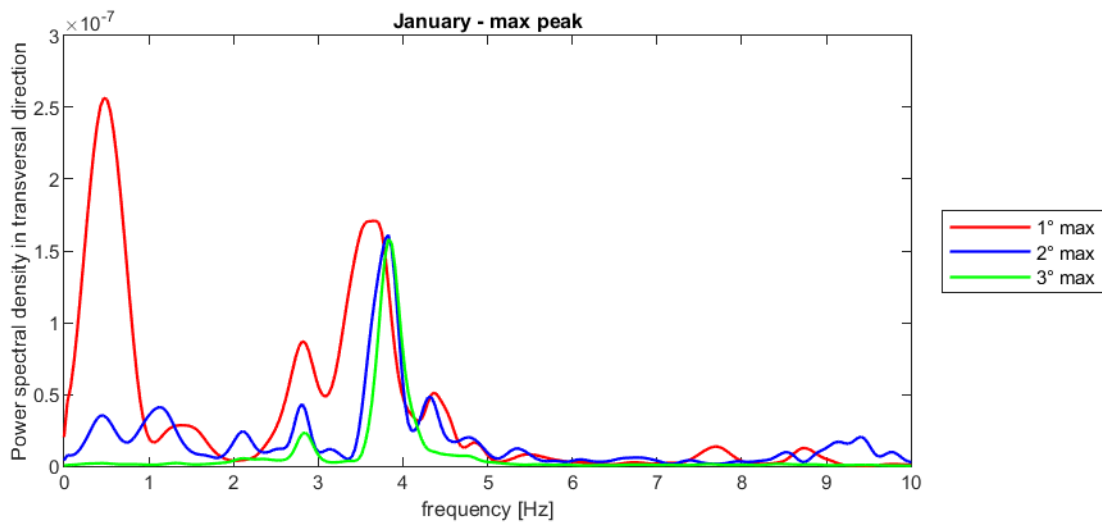

Figure 0-12: Results obtained from the 3 accelerograms with highest peak in PSD

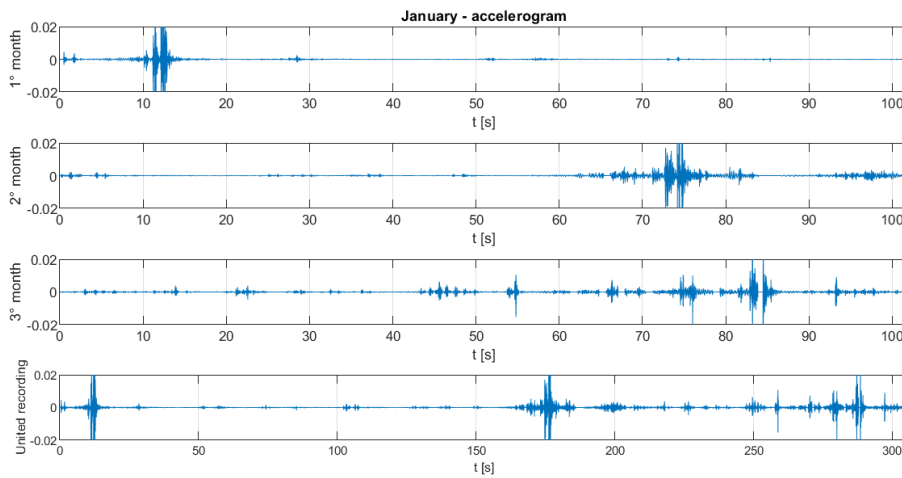

Figure 0-13: Accelerograms in transverse (z) direction with maximum standard deviation in time domain

10.2 February

The results obtained for the February dataset are shown in the following tables.

Table 0-4: February 2023 - Accelerograms with the maximum standard deviation

	#	Accelerogram	Standard deviation
Vertical direction (x)	1°	319E3_2023-02-01_13-00-20	1.03E-04
	2°	319E3_2023-02-17_13-00-20	1.01E-04
	3°	319E3_2023-02-08_13-00-20	1.00E-04
Longitudinal direction (y)	1°	319E3_2023-02-06_13-00-20	7.48E-04
	2°	319E3_2023-02-23_13-00-20	7.04E-04
	3°	319E3_2023-02-01_13-00-20	6.96E-04
Transverse direction (z)	1°	319E3_2023-02-07_13-00-20	6.32E-04
	2°	319E3_2023-02-17_13-00-20	6.12E-04
	3°	319E3_2023-02-01_13-00-20	5.34E-04

Table 0-5: February 2023 - Accelerograms defined by the maximum area and peak of the power spectral density function

Vertical direction (x)				
#	Accelerogram	Peak value	Accelerogram	Area
1	319E3_2023-02-01_13-00-20	1.03E-08	319E3_2023-02-08_13-00-20	2.09E-09
2	319E3_2023-02-06_13-00-20	7.29E-09	319E3_2023-02-01_13-00-20	2.07E-09
3	319E3_2023-02-08_13-00-20	4.39E-09	319E3_2023-02-06_13-00-20	1.99E-09
Longitudinal direction (y)				
	Accelerogram	Peak value	Accelerogram	Area
1	319E3_2023-02-17_13-00-20	5.43E-07	319E3_2023-02-06_13-00-20	1.12E-07
2	319E3_2023-02-01_13-00-20	5.25E-07	319E3_2023-02-23_13-00-20	1.08E-07
3	319E3_2023-02-23_13-00-20	4.62E-07	319E3_2023-02-01_13-00-20	1.01E-07
Transverse direction (z)				
	Accelerogram	Peak value	Accelerogram	Area
1	319E3_2023-02-01_13-00-20	4.22E-07	319E3_2023-02-07_13-00-20	7.76E-08
2	319E3_2023-02-06_13-00-20	2.10E-07	319E3_2023-02-17_13-00-20	6.67E-08
3	319E3_2023-02-17_13-00-20	1.82E-07	319E3_2023-02-08_13-00-20	5.51E-08

Table 0-6: February 2023 – Statistical analysis

	Vertical X			Longitudinal Y			Transverse Z		
	Std	Peak	Area	Std	Peak	Area	Std	Peak	Area
1	A	A	C	D	-	D	F	A	F
2	-	D	A	E	A	E	B	-	B
3	C	C	D	A	E	A	A	B	-

10.2.1 Vertical direction (x)

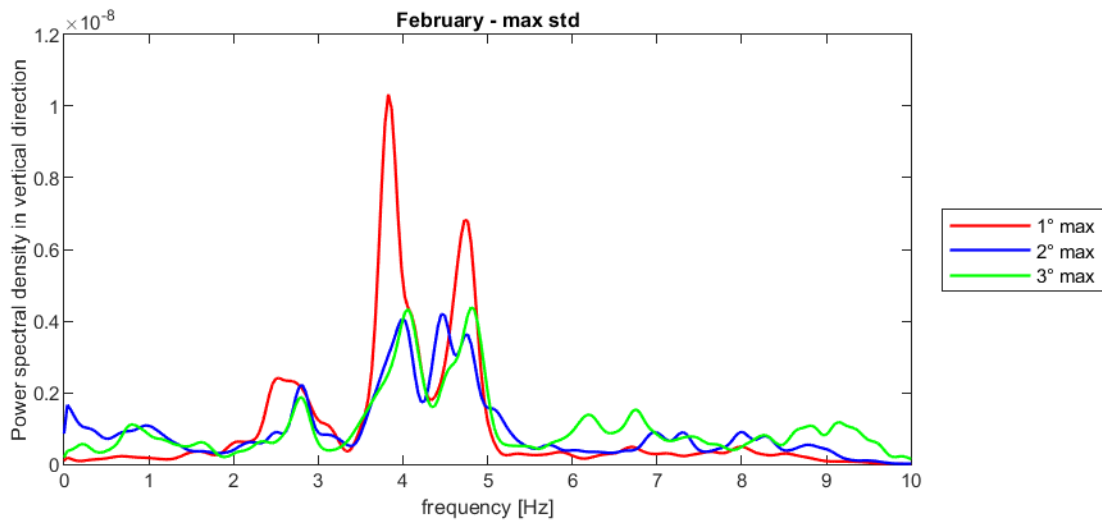

Figure 0-14: Results obtained from the 3 accelerograms with maximum SD in time domain

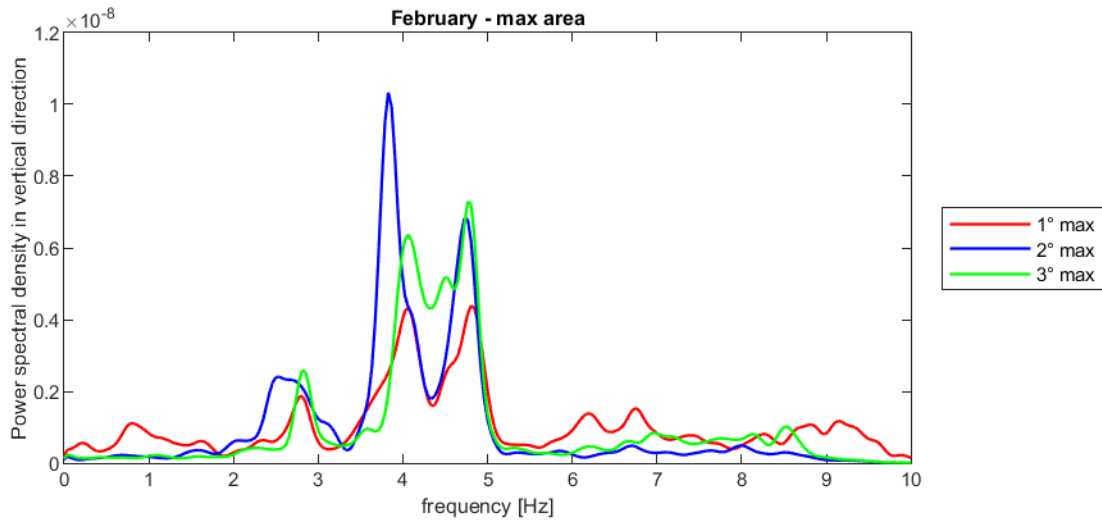

Figure 0-15: Results obtained from the 3 accelerograms with maximum area of PSD

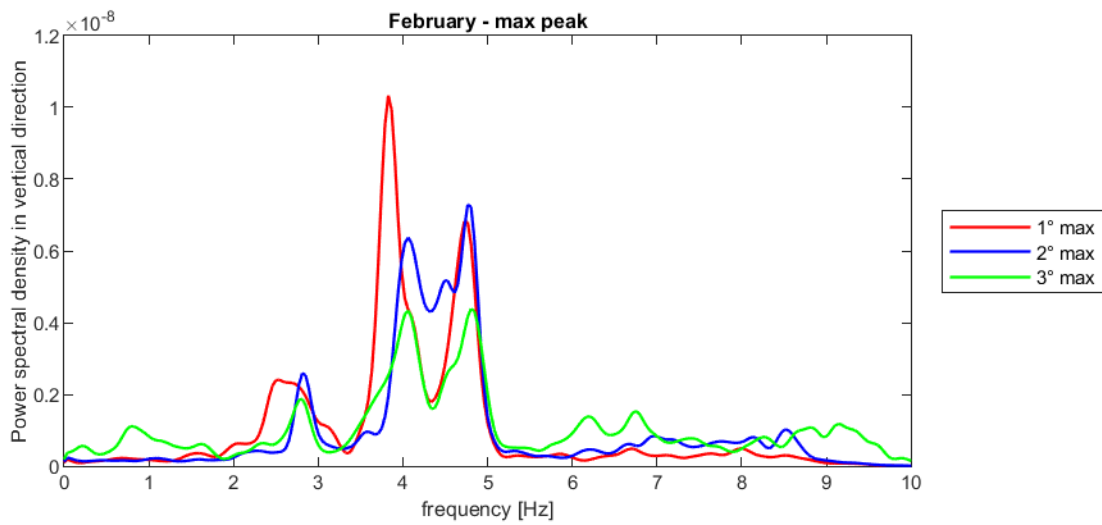

Figure 0-16: Results obtained from the 3 accelerograms with highest peak if PSD

Monitoring activity on Fiorenza Node of A4 Highway

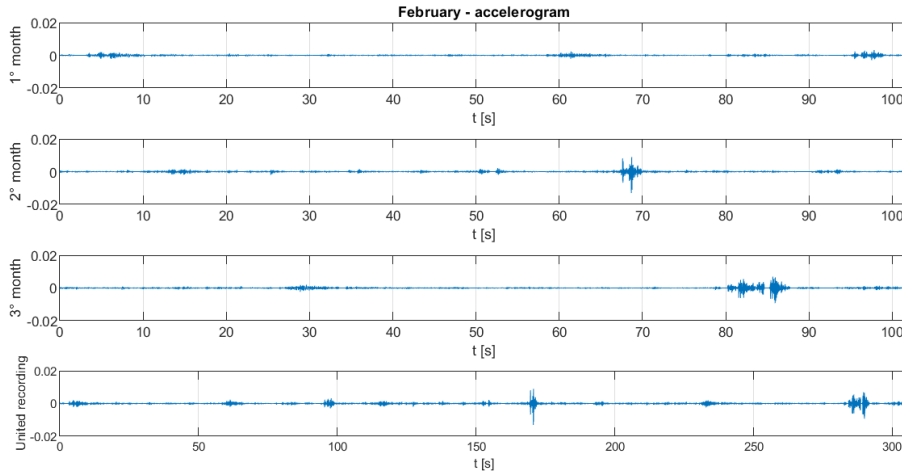

Figure 0-17: Accelerograms in vertical (x) direction with maximum standard deviation in time domain

10.2.2 Longitudinal direction (y)

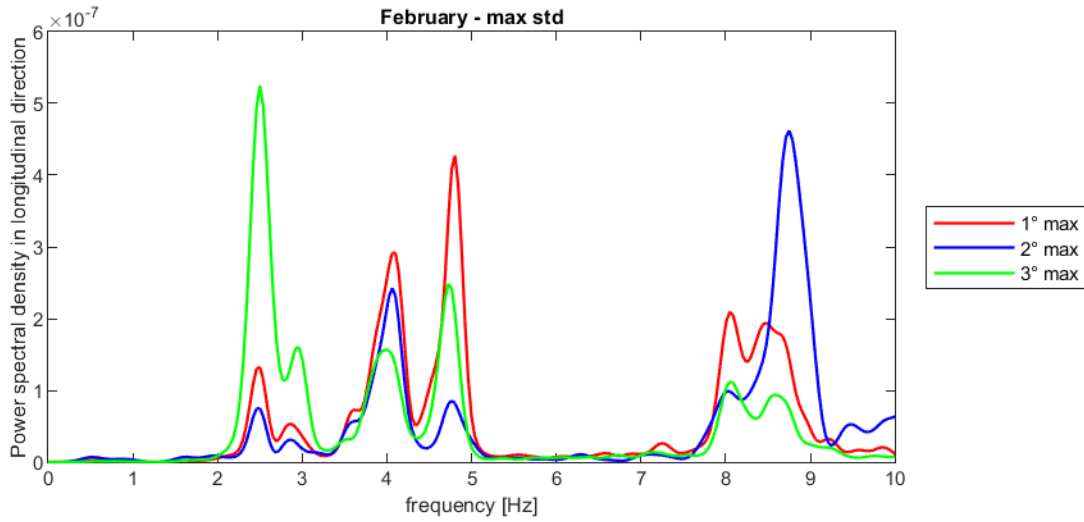

Figure 0-18: Results obtained from the 3 accelerograms with maximum SD in time domain

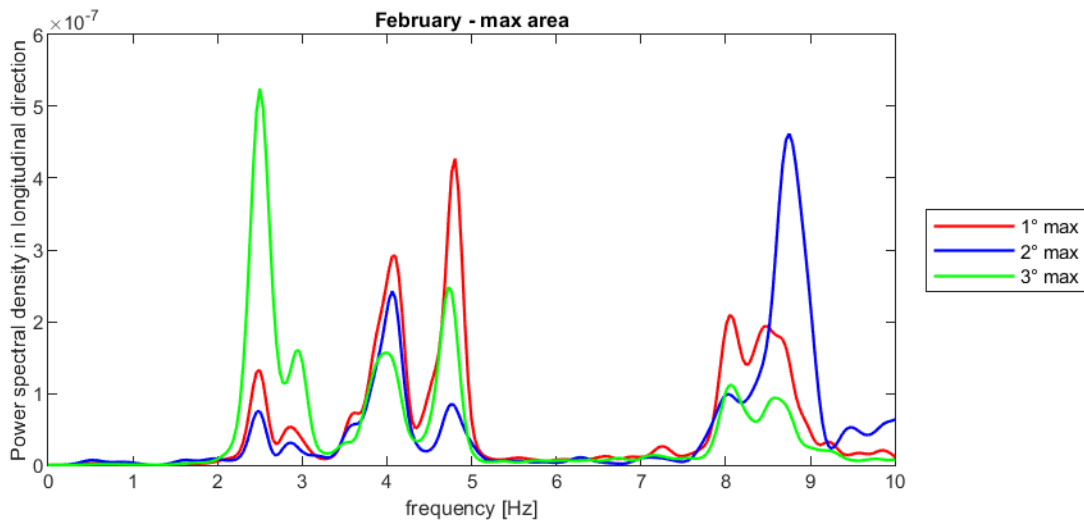

Figure 0-19: Results obtained from the 3 accelerograms with maximum area of PSD

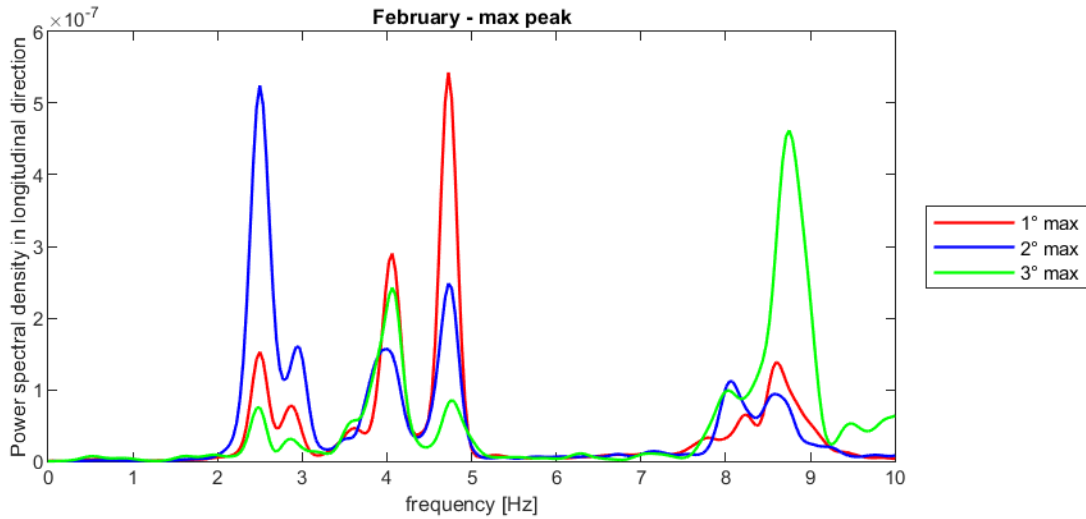

Figure 0-20: Results obtained from the 3 accelerograms with highest peak if PSD

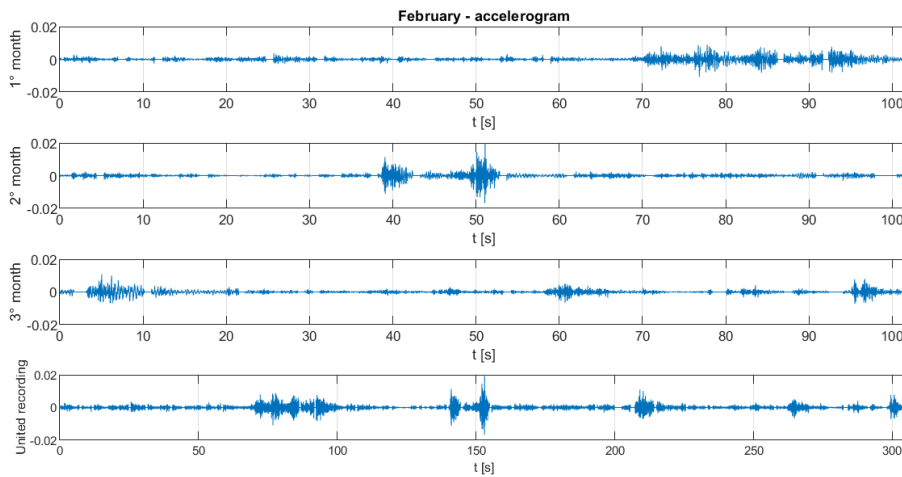

Figure 0-21: Accelerograms in longitudinal (y) direction with maximum standard deviation in time domain

10.2.3 Transverse direction (z)

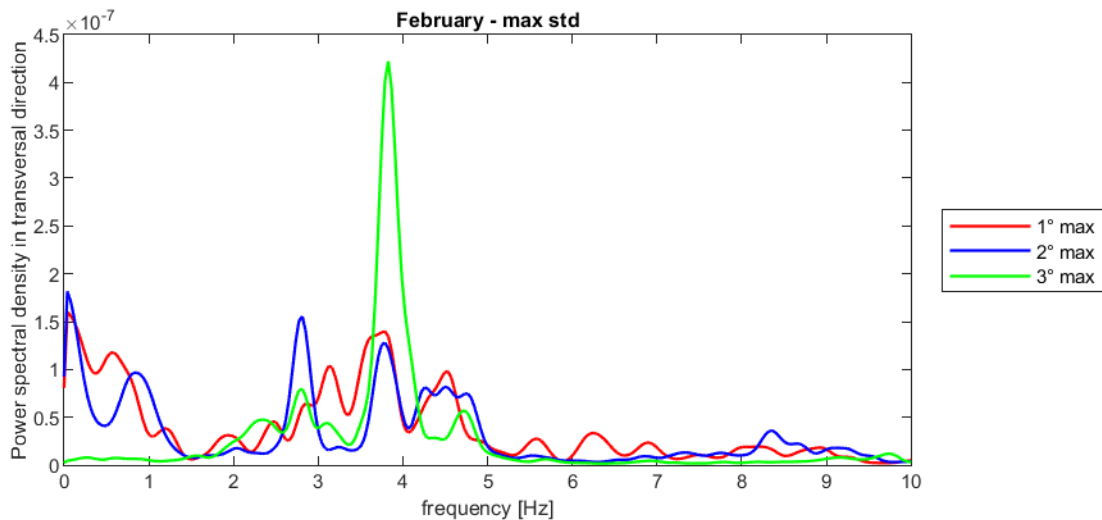

Figure 0-22: Results obtained from the 3 accelerograms with maximum SD in time domain

Monitoring activity on Fiorenza Node of A4 Highway

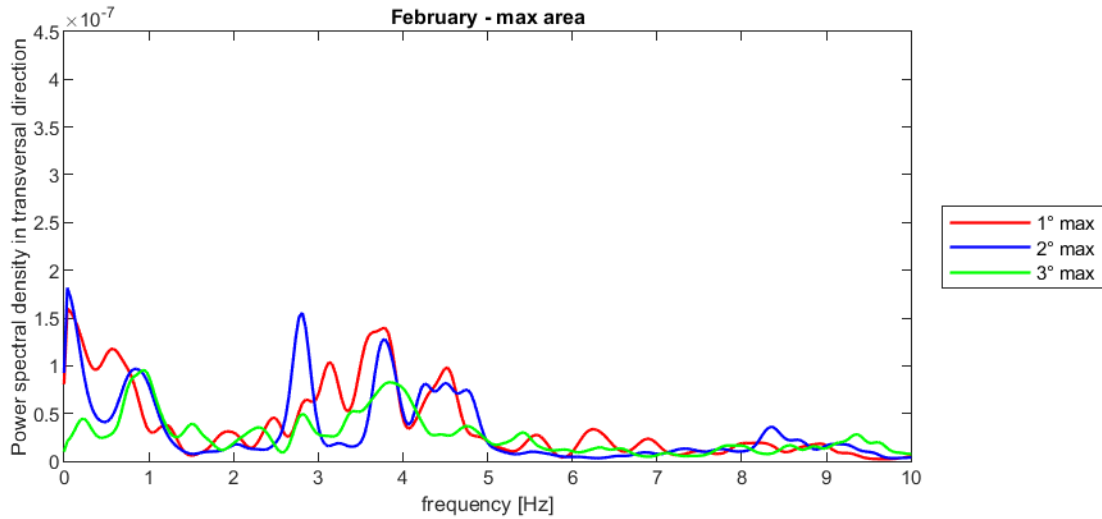

Figure 0-23: Results obtained from the 3 accelerograms with maximum area of PSD

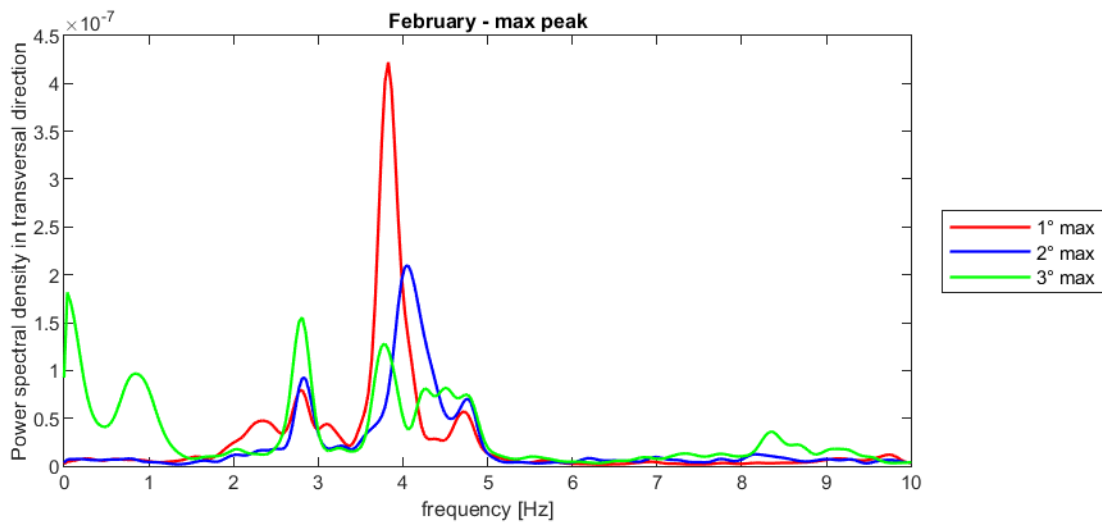

Figure 0-24: Results obtained from the 3 accelerograms with highest peak if PSD

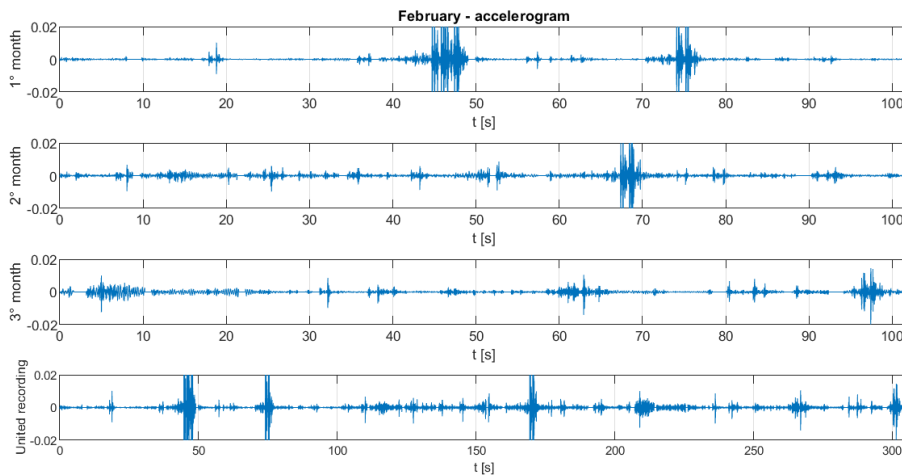

Figure 0-25: Accelerograms in transverse (z) direction with maximum standard deviation in time domain

10.3 March

The results obtained for the March dataset are shown in the following tables.

Table 0-7: March 2023 - Accelerograms with the maximum standard deviation

	#	Accelerogram	Standard deviation
Vertical direction (x)	1°	319E3_2023-03-16_13-00-20	1.49E-04
	2°	319E3_2023-03-04_13-00-20	1.30E-04
	3°	319E3_2023-03-31_08-00-20	1.02E-04
Longitudinal direction (y)	1°	319E3_2023-03-16_13-00-20	1.13E-03
	2°	319E3_2023-03-04_13-00-20	8.94E-04
	3°	319E3_2023-03-08_13-00-21	7.80E-04
Transverse direction (z)	1°	319E3_2023-03-16_13-00-20	7.51E-04
	2°	319E3_2023-03-04_13-00-20	6.84E-04
	3°	319E3_2023-03-18_07-00-20	6.17E-04

Table 0-8: March 2023 - Accelerograms defined by the maximum area and peak of the power spectral density function

Vertical direction (x)				
#	Accelerogram	Peak value	Accelerogram	Area
1	319E3_2023-03-04_13-00-20	1.56E-08	319E3_2023-03-16_13-00-20	4.57E-09
2	319E3_2023-03-16_13-00-20	1.45E-08	319E3_2023-03-04_13-00-20	3.52E-09
3	319E3_2023-03-18_07-00-20	7.32E-09	319E3_2023-03-31_08-00-20	2.16E-09
Longitudinal direction (y)				
	Accelerogram	Peak value	Accelerogram	Area
1	319E3_2023-03-16_13-00-20	1.41E-06	319E3_2023-03-16_13-00-20	2.68E-07
2	319E3_2023-03-29_14-00-21	7.27E-07	319E3_2023-03-04_13-00-20	1.66E-07
3	319E3_2023-03-08_13-00-21	6.85E-07	319E3_2023-03-08_13-00-21	1.25E-07
Transverse direction (z)				
	Accelerogram	Peak value	Accelerogram	Area
1	319E3_2023-03-16_13-00-20	4.61E-07	319E3_2023-03-16_13-00-20	1.16E-07
2	319E3_2023-03-04_13-00-20	4.31E-07	319E3_2023-03-04_13-00-20	9.77E-08
3	319E3_2023-03-14_13-00-20	2.72E-07	319E3_2023-03-14_13-00-20	7.84E-08

Table 0-9: March 2023 – Statistical analysis

	Vertical X			Longitudinal Y			Transverse Z		
	Std	Peak	Area	Std	Peak	Area	Std	Peak	Area
1	A	B	A	A	A	A	A	A	A
2	B	A	B	B	-	B	B	B	B
3	C	-	C	D	D	D	-	E	E

10.3.1 Vertical direction (x)

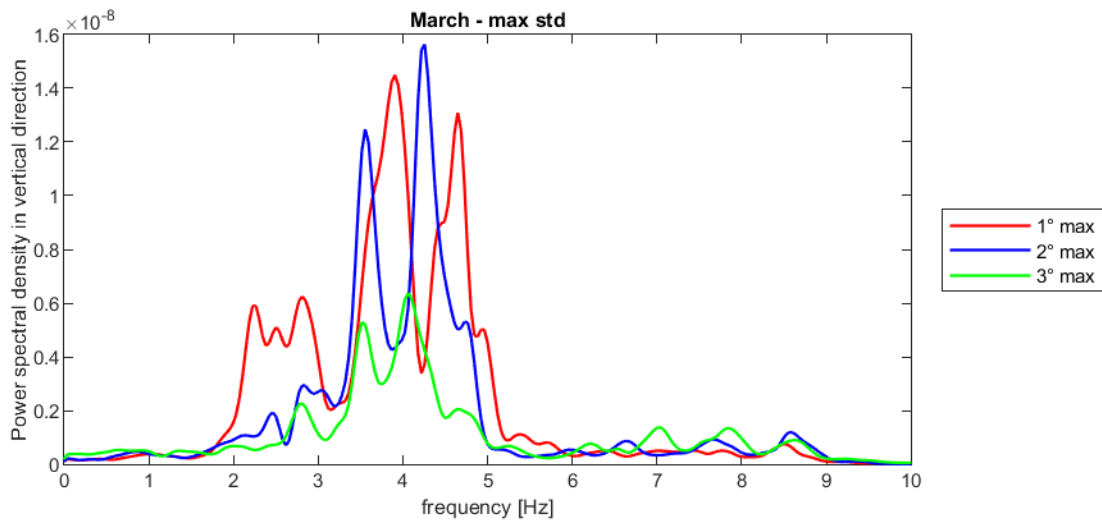

Figure 0-26: Results obtained from the 3 accelerograms with maximum SD in time domain

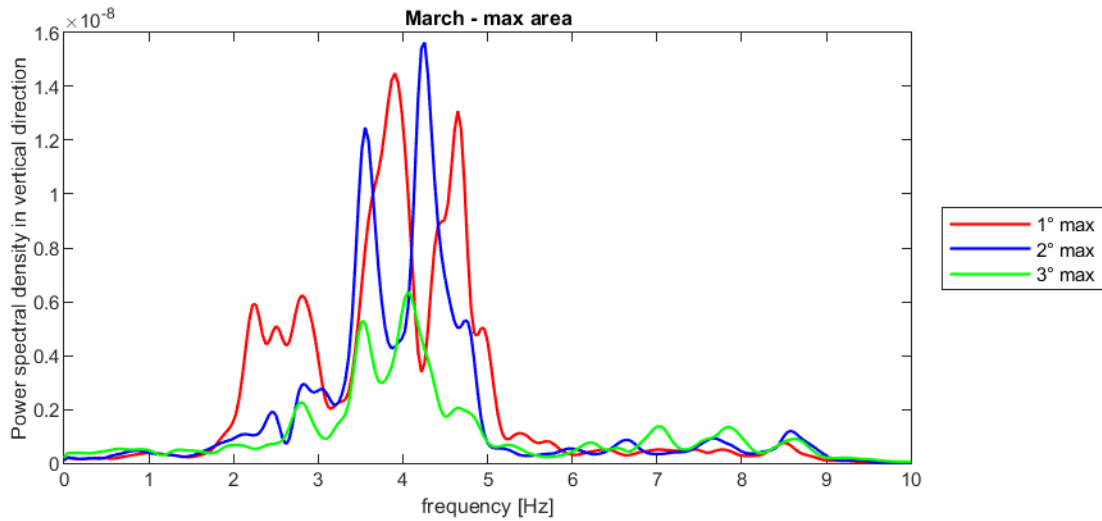

Figure 0-27: Results obtained from the 3 accelerograms with maximum area of PSD

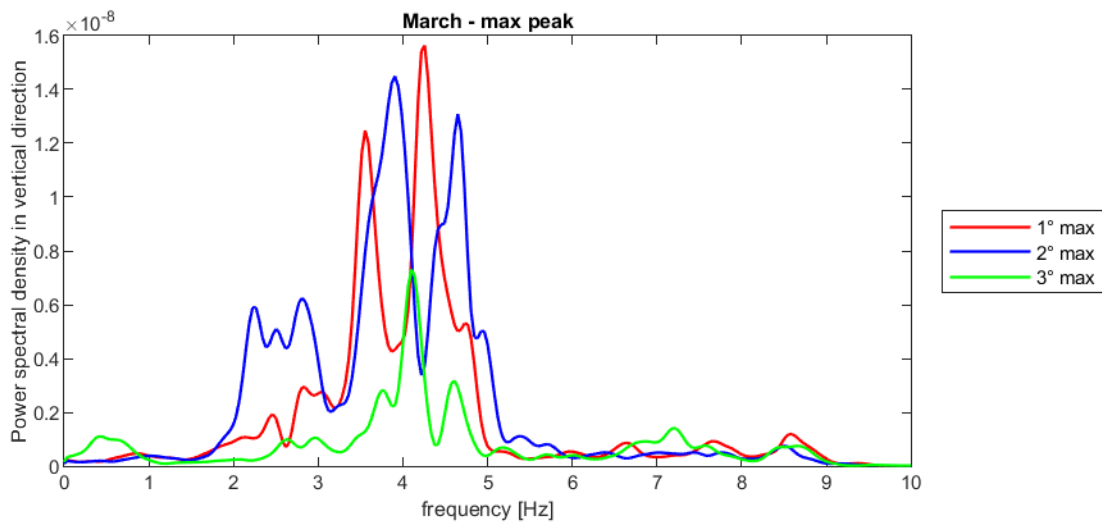

Figure 0-28: Results obtained from the 3 accelerograms with highest peak if PSD

Monitoring activity on Fiorenza Node of A4 Highway

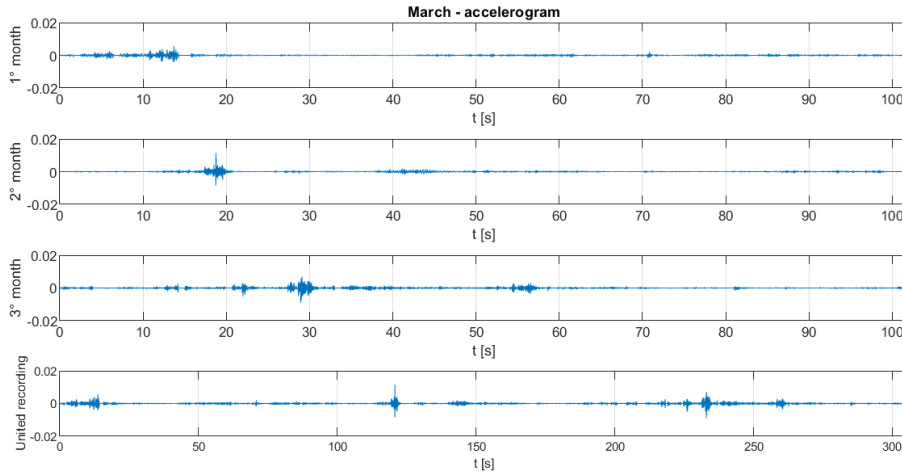

Figure 0-29: Accelerograms in vertical (x) direction with maximum standard deviation in time domain

10.3.2 Longitudinal direction (y)

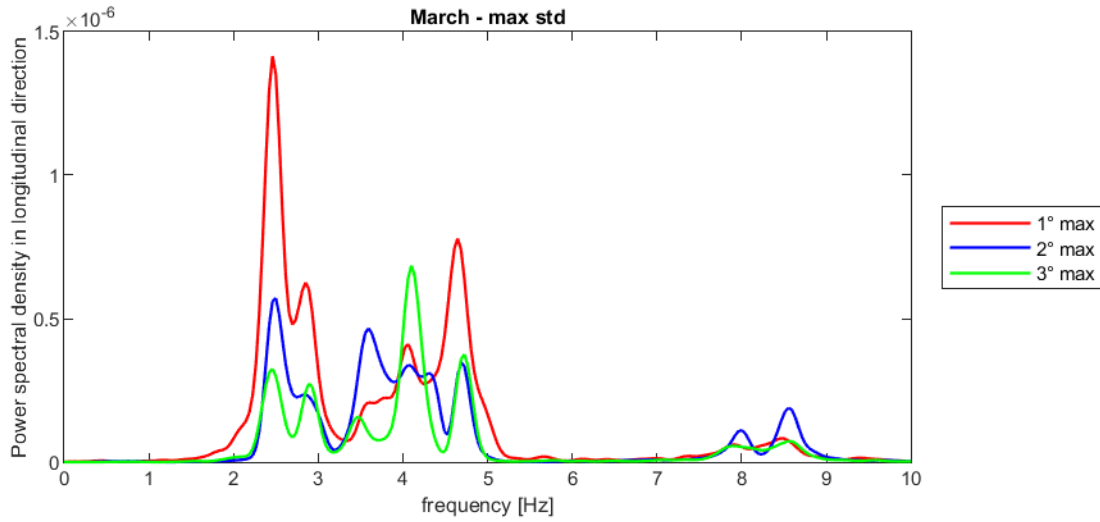

Figure 0-30: Results obtained from the 3 accelerograms with maximum SD in time domain

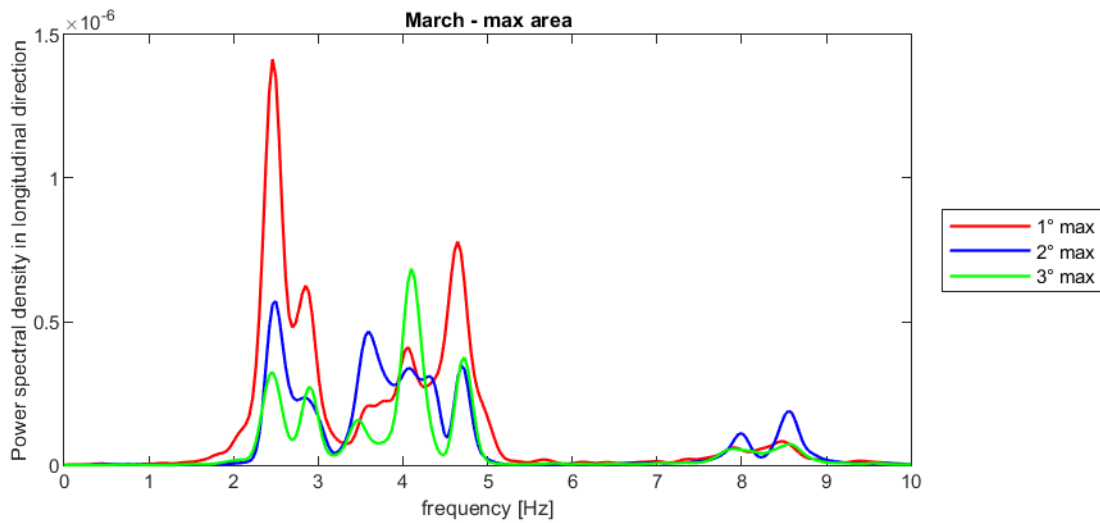

Figure 0-31: Results obtained from the 3 accelerograms with maximum area of PSD

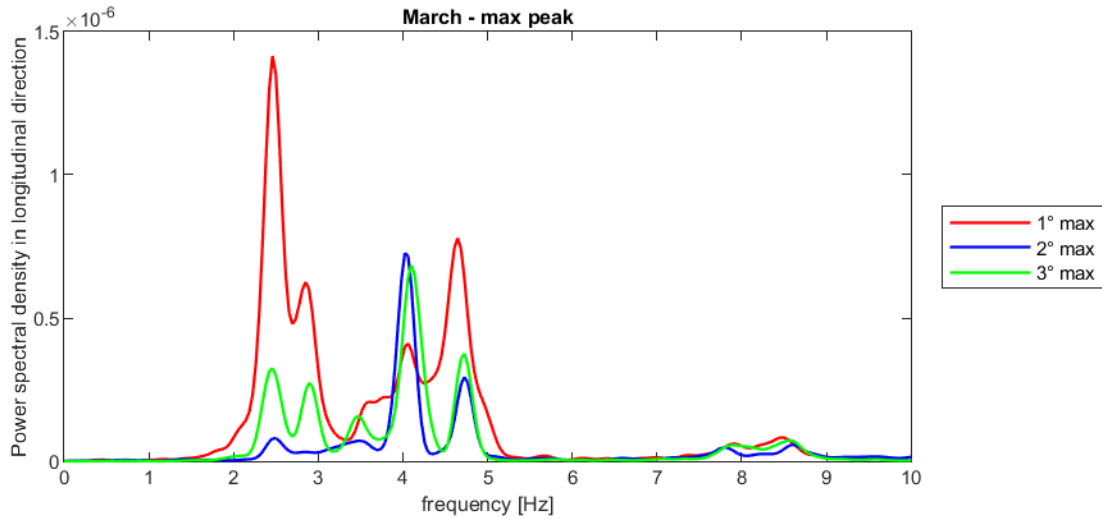

Figure 0-32: Results obtained from the 3 accelerograms with highest peak if PSD

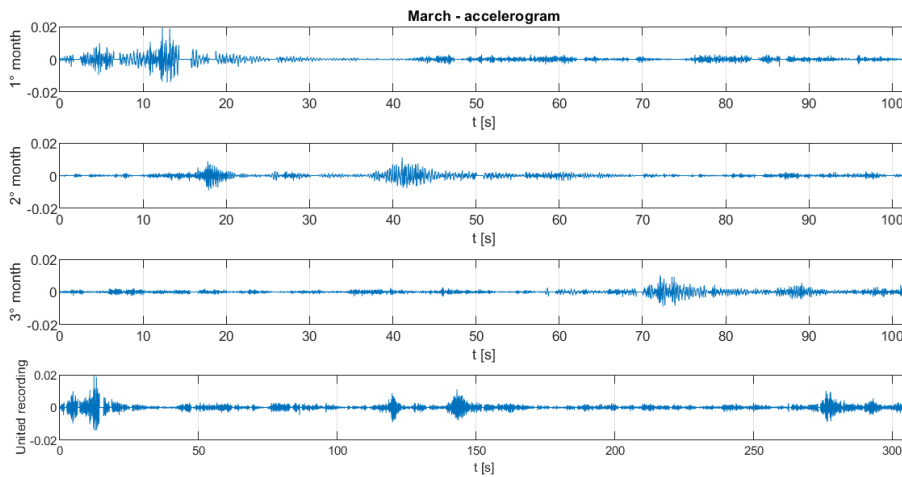

Figure 0-33: Accelerograms in longitudinal (y) direction with maximum standard deviation in time domain

10.3.3 Transverse direction (z)

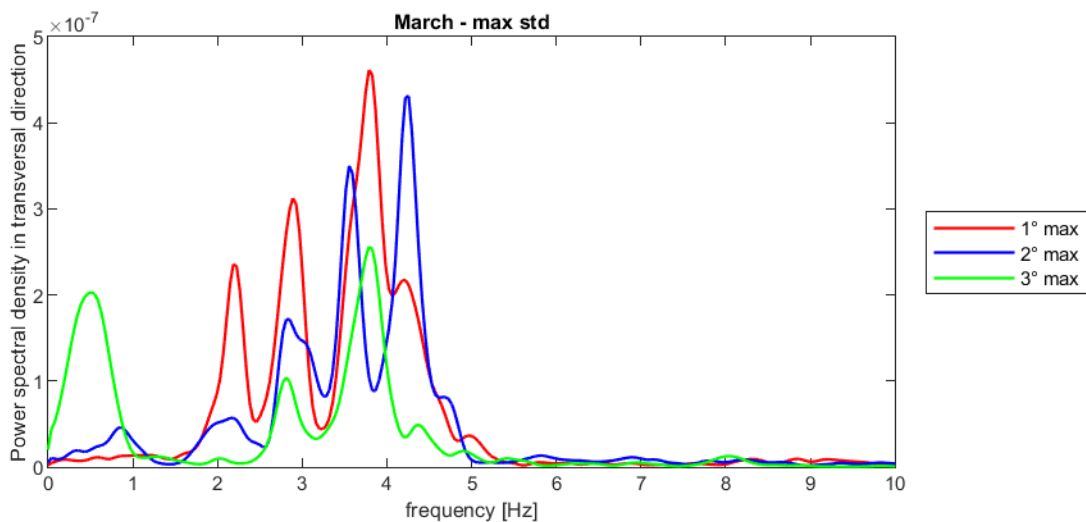

Figure 0-34: Results obtained from the 3 accelerograms with maximum SD in time domain

Monitoring activity on Fiorenza Node of A4 Highway

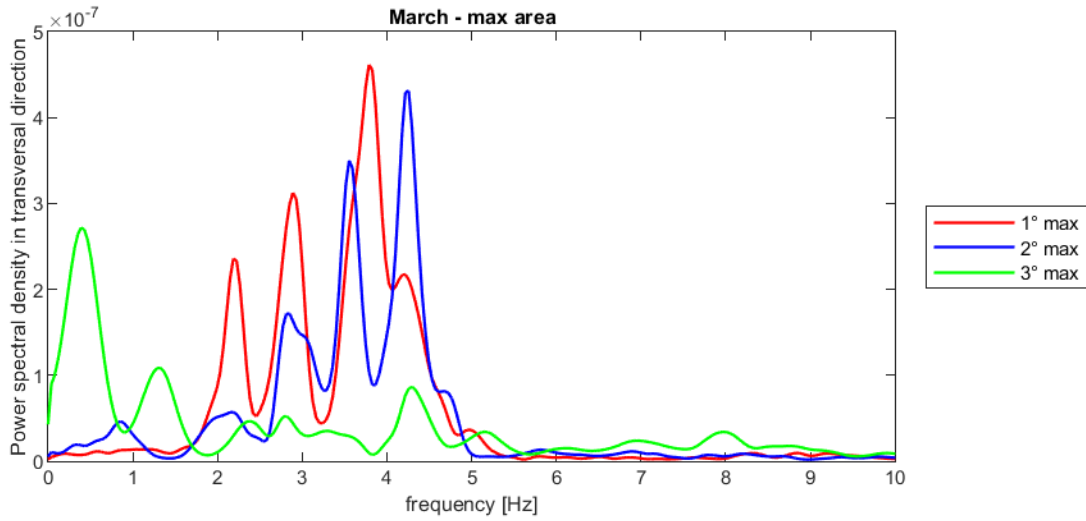

Figure 0-35: Results obtained from the 3 accelerograms with maximum area of PSD

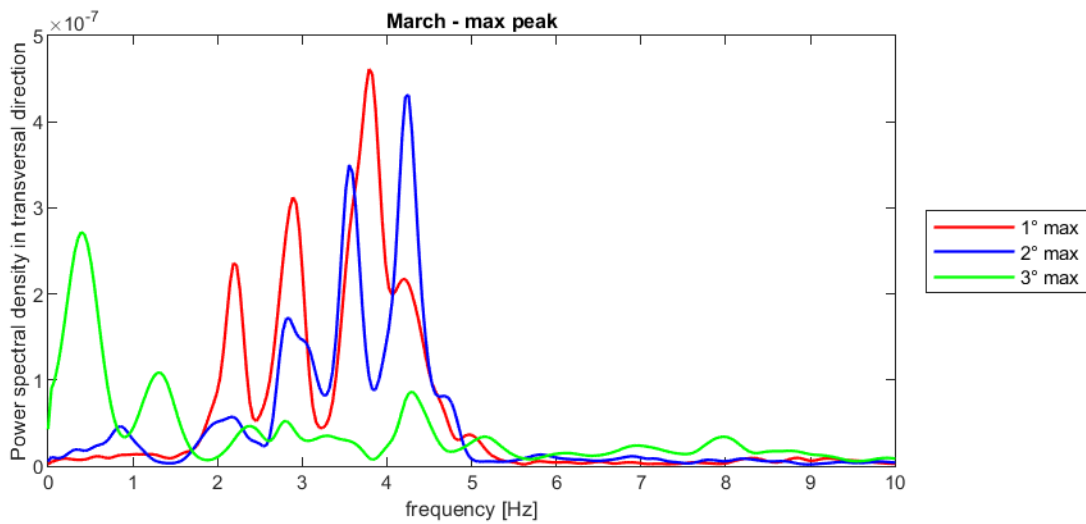

Figure 0-36: Results obtained from the 3 accelerograms with highest peak if PSD

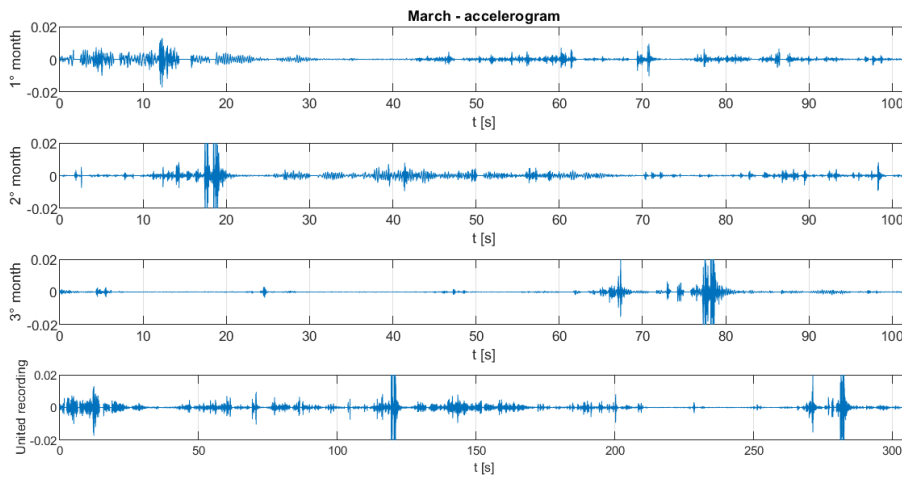

Figure 0-37: Accelerograms in transverse (z) direction with maximum standard deviation in time domain

10.4 April

The results obtained for the April dataset are shown in the following tables.

Table 0-10: April 2023 - Accelerograms with the maximum standard deviation

	#	Accelerogram	Standard deviation
Vertical direction (x)	1°	319E3_2023-04-13_08-00-21	1.33E-04
	2°	319E3_2023-04-18_14-00-20	1.13E-04
	3°	319E3_2023-04-24_14-00-21	1.10E-04
Longitudinal direction (y)	1°	319E3_2023-04-13_08-00-21	1.12E-03
	2°	319E3_2023-04-18_14-00-20	7.42E-04
	3°	319E3_2023-04-24_14-00-21	7.19E-04
Transverse direction (z)	1°	319E3_2023-04-13_08-00-21	1.01E-03
	2°	319E3_2023-04-24_14-00-21	7.35E-04
	3°	319E3_2023-04-18_14-00-20	6.90E-04

Table 0-11: April 2023 - Accelerograms defined by the maximum area and peak of the power spectral density function

Vertical direction (x)				
#	Accelerogram	Peak value	Accelerogram	Area
1	319E3_2023-04-24_14-00-21	1.08E-08	319E3_2023-04-13_08-00-21	3.53E-09
2	319E3_2023-04-13_08-00-21	1.04E-08	319E3_2023-04-18_14-00-20	2.69E-09
3	319E3_2023-04-18_14-00-20	9.32E-09	319E3_2023-04-24_14-00-21	2.45E-09
Longitudinal direction (y)				
	Accelerogram	Peak value	Accelerogram	Area
1	319E3_2023-04-13_08-00-21	1.48E-06	319E3_2023-04-13_08-00-21	2.59E-07
2	319E3_2023-04-18_14-00-20	5.54E-07	319E3_2023-04-18_14-00-20	1.11E-07
3	319E3_2023-04-04_14-00-20	5.15E-07	319E3_2023-04-24_14-00-21	1.04E-07
Transverse direction (z)				
	Accelerogram	Peak value	Accelerogram	Area
1	319E3_2023-04-13_08-00-21	8.78E-07	319E3_2023-04-13_08-00-21	2.03E-07
2	319E3_2023-04-24_14-00-21	8.07E-07	319E3_2023-04-24_14-00-21	1.15E-07
3	319E3_2023-04-18_14-00-20	5.16E-07	319E3_2023-04-18_14-00-20	9.62E-08

Table 0-12: April 2023 – Statistical analysis

	Vertical X			Longitudinal Y			Transverse Z		
	Std	Peak	Area	Std	Peak	Area	Std	Peak	Area
1	A	C	A	A	A	A	A	A	A
2	B	A	B	B	B	B	C	C	C
3	C	B	C	C	-	C	B	B	B

10.4.1 Vertical direction (x)

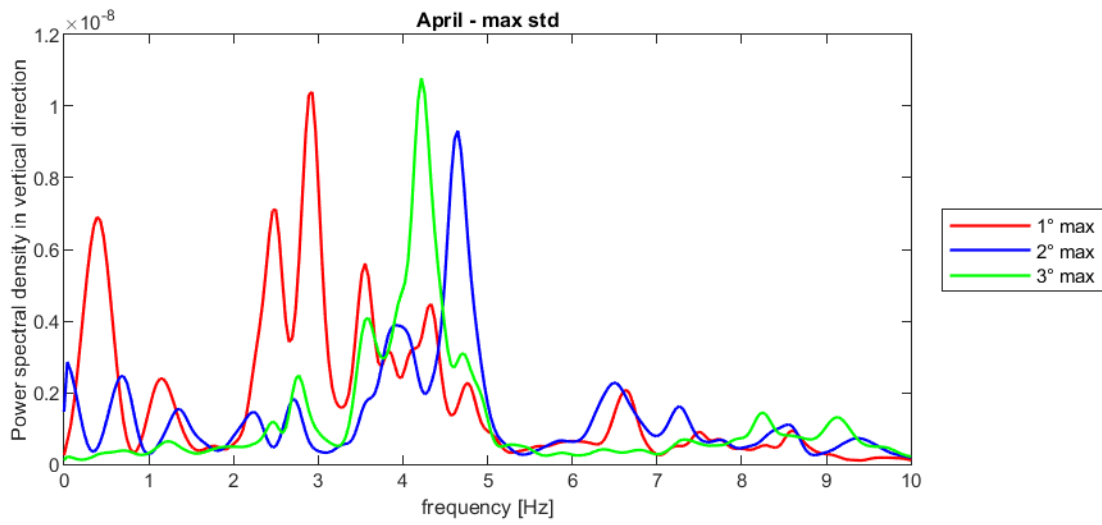

Figure 0-38: Results obtained from the 3 accelerograms with maximum SD in time domain

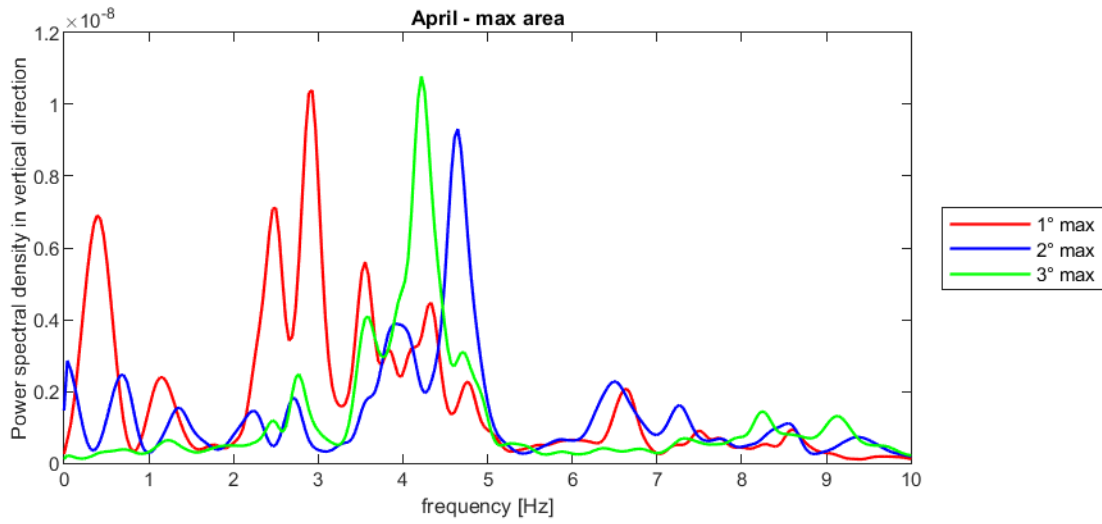

Figure 0-39: Results obtained from the 3 accelerograms with maximum area of PSD

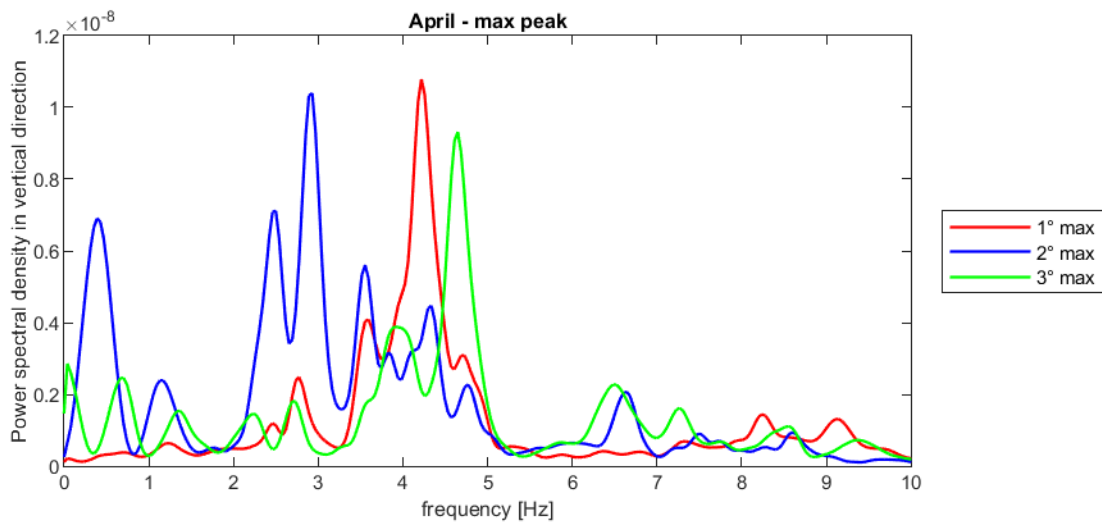

Figure 0-40: Results obtained from the 3 accelerograms with highest peak if PSD

Monitoring activity on Fiorenza Node of A4 Highway

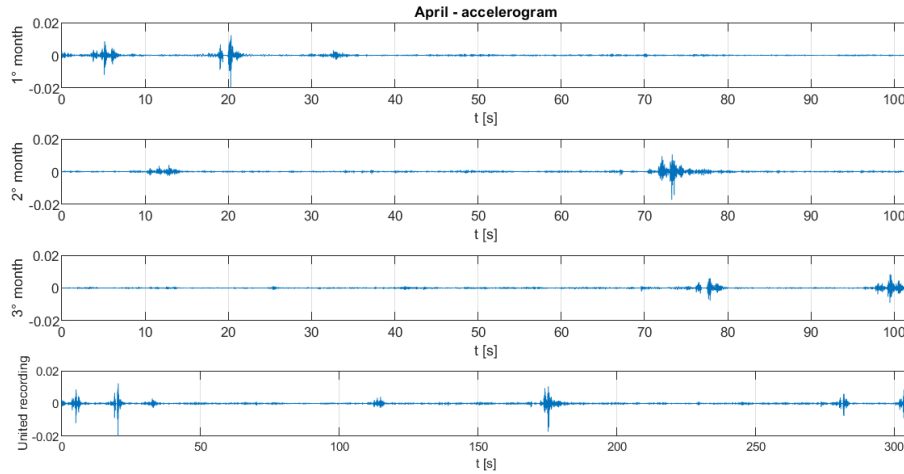

Figure 0-41: Accelerograms in vertical (x) direction with maximum standard deviation in time domain

10.4.2 Longitudinal direction (y)

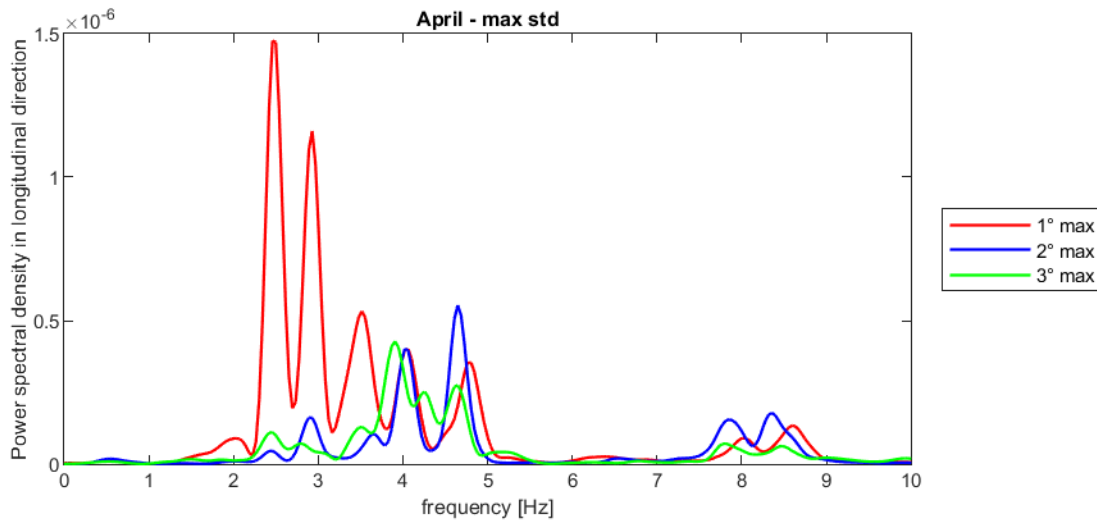

Figure 0-42: Results obtained from the 3 accelerograms with maximum SD in time domain

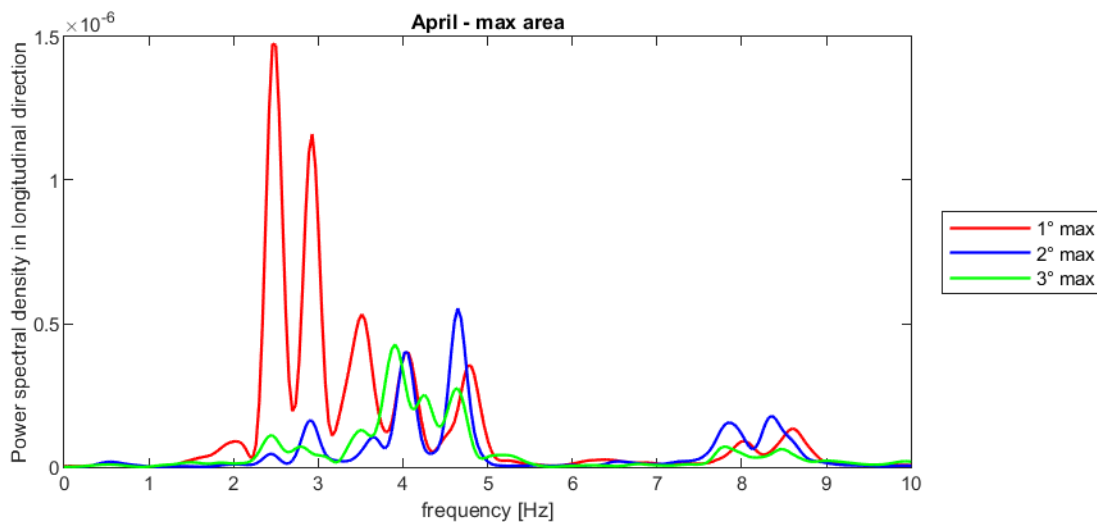

Figure 0-43: Results obtained from the 3 accelerograms with maximum area of PSD

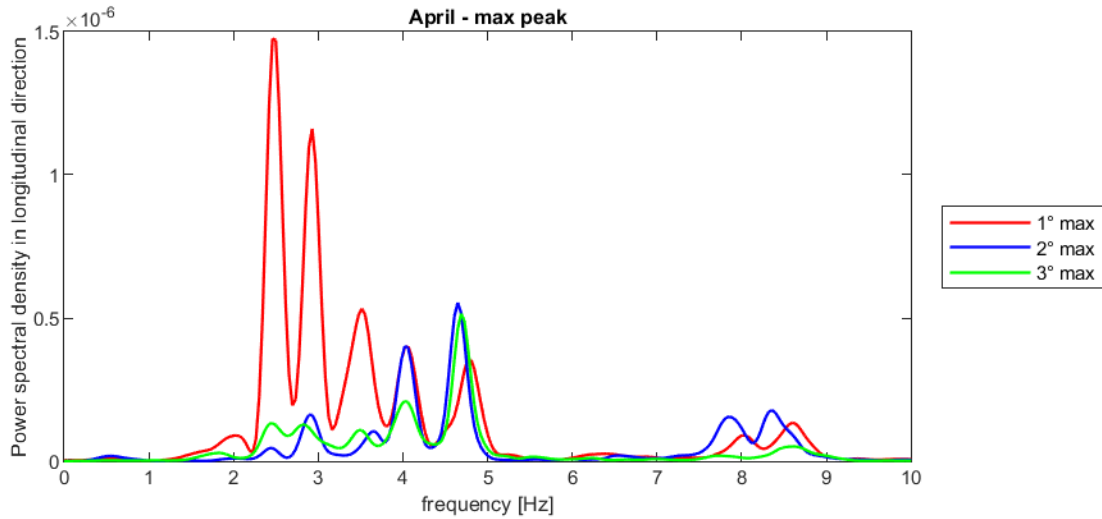

Figure 0-44: Results obtained from the 3 accelerograms with highest peak if PSD

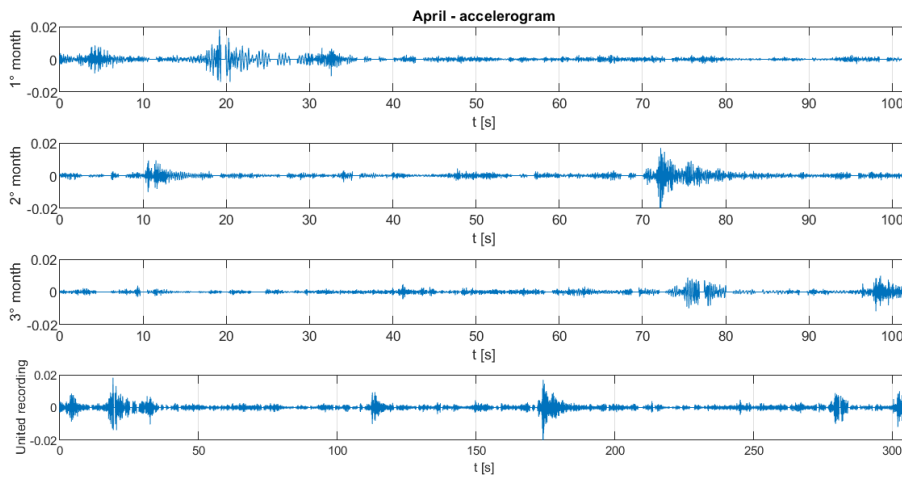

Figure 0-45: Accelerograms in longitudinal (y) direction with maximum standard deviation in time domain

10.4.3 Transverse direction (z)

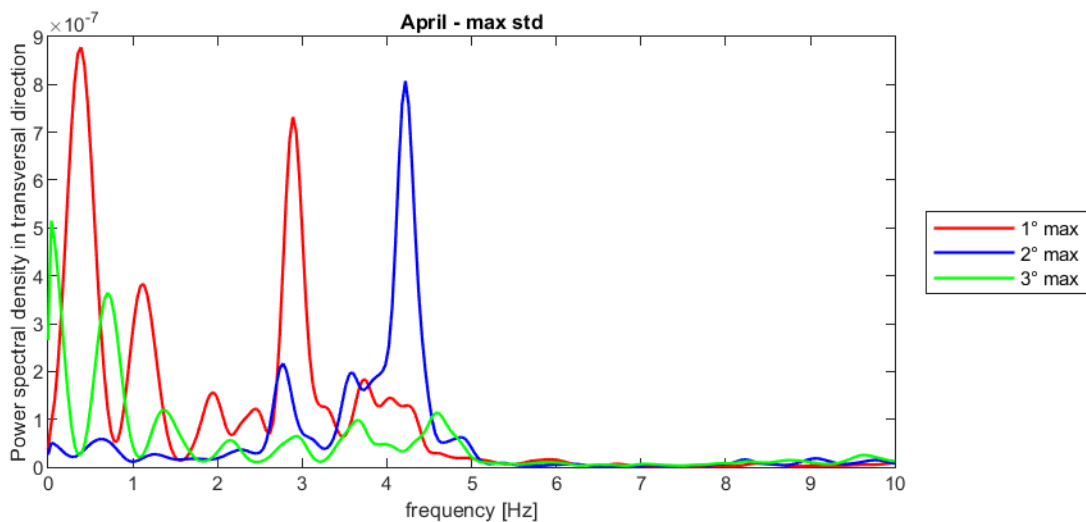

Figure 0-46: Results obtained from the 3 accelerograms with maximum SD in time domain

Monitoring activity on Fiorenza Node of A4 Highway

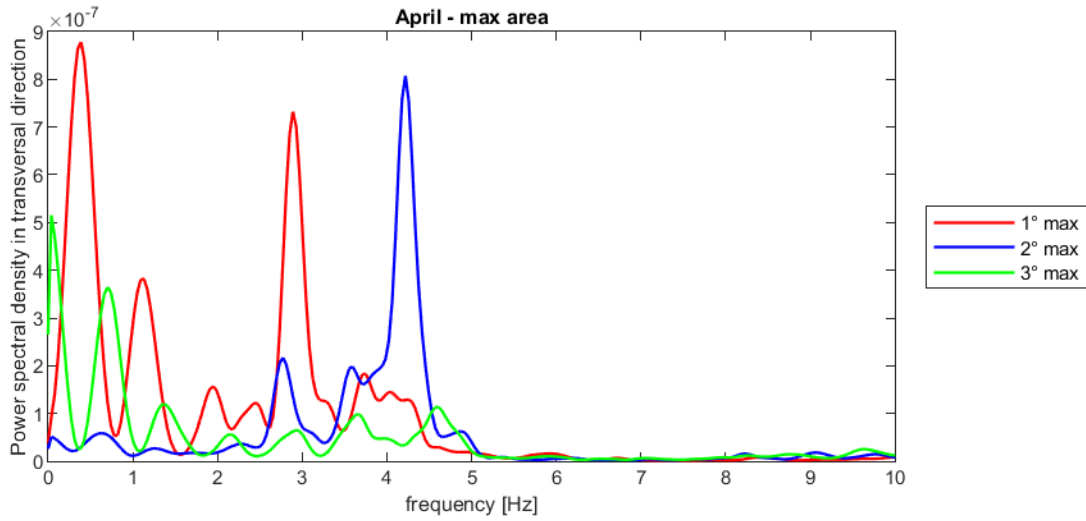

Figure 0-47: Results obtained from the 3 accelerograms with maximum area of PSD

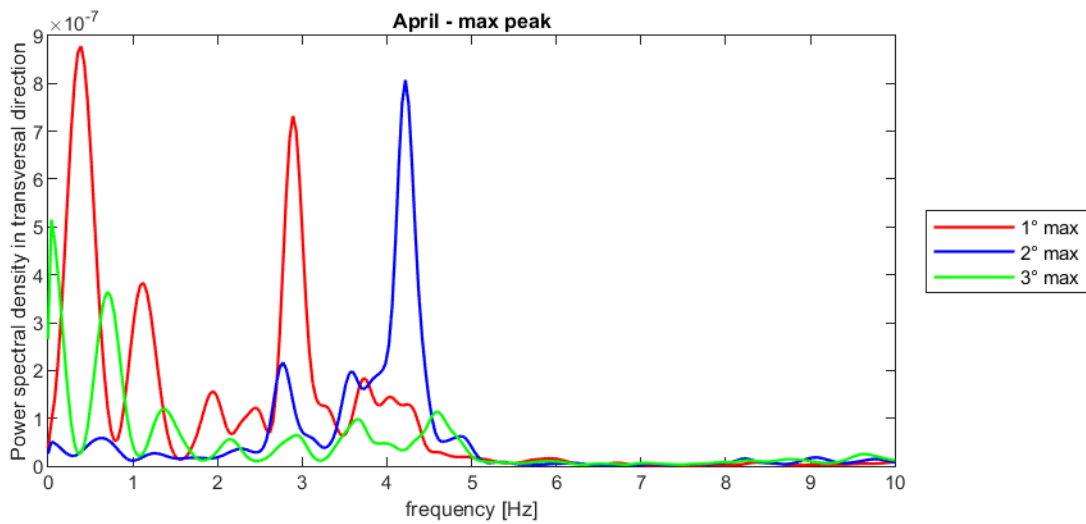

Figure 0-48: Results obtained from the 3 accelerograms with highest peak if PSD

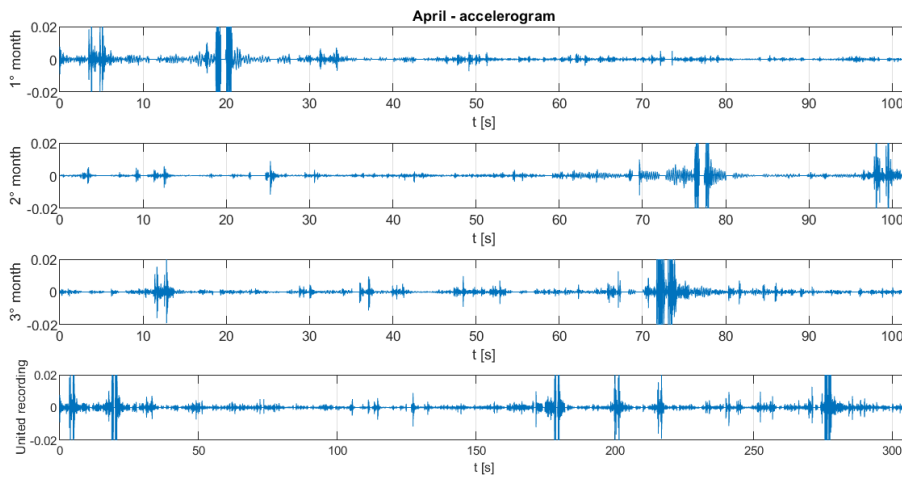

Figure 0-49: Accelerograms in transverse (z) direction with maximum standard deviation in time domain

10.5 May

The results obtained for the May dataset are shown in the following tables.

Table 0-13: May 2023 - Accelerograms with the maximum standard deviation

	#	Accelerogram	Standard deviation
Vertical direction (x)	1°	319E3_2023-05-23_14-00-20	1.46E-04
	2°	319E3_2023-05-04_14-00-20	1.12E-04
	3°	319E3_2023-05-15_08-00-20	9.22E-05
Longitudinal direction (y)	1°	319E3_2023-05-23_14-00-20	1.34E-03
	2°	319E3_2023-05-04_14-00-20	8.25E-04
	3°	319E3_2023-05-22_08-00-21	7.71E-04
Transverse direction (z)	1°	319E3_2023-05-23_14-00-20	8.57E-04
	2°	319E3_2023-05-04_14-00-20	6.10E-04
	3°	319E3_2023-05-15_08-00-20	5.63E-04

Table 0-14: May 2023 - Accelerograms defined by the maximum area and peak of the power spectral density function

Vertical direction (x)				
#	Accelerogram	Peak value	Accelerogram	Area
1	319E3_2023-05-23_14-00-20	1.48E-08	319E3_2023-05-23_14-00-20	3.89E-09
2	319E3_2023-05-04_14-00-20	1.10E-08	319E3_2023-05-04_14-00-20	2.79E-09
3	319E3_2023-05-22_08-00-21	6.88E-09	319E3_2023-05-22_08-00-21	1.70E-09
Longitudinal direction (y)				
	Accelerogram	Peak value	Accelerogram	Area
1	319E3_2023-05-23_14-00-20	3.28E-06	319E3_2023-05-23_14-00-20	3.65E-07
2	319E3_2023-05-04_14-00-20	5.74E-07	319E3_2023-05-04_14-00-20	1.46E-07
3	319E3_2023-05-22_08-00-21	5.69E-07	319E3_2023-05-22_08-00-21	1.24E-07
Transverse direction (z)				
	Accelerogram	Peak value	Accelerogram	Area
1	319E3_2023-05-04_14-00-20	5.14E-07	319E3_2023-05-23_14-00-20	1.09E-07
2	319E3_2023-05-23_14-00-20	4.94E-07	319E3_2023-05-04_14-00-20	7.91E-08
3	319E3_2023-05-15_08-00-20	1.97E-07	319E3_2023-05-02_08-00-21	6.62E-08

Table 0-15: May 2023 – Statistical analysis

	Vertical X			Longitudinal Y			Transverse Z		
	Std	Peak	Area	Std	Peak	Area	Std	Peak	Area
1	A	A	A	A	A	A	A	B	A
2	B	B	B	B	B	B	B	A	B
3	-	D	D	D	D	D	C	C	-

10.5.1 Vertical direction (x)

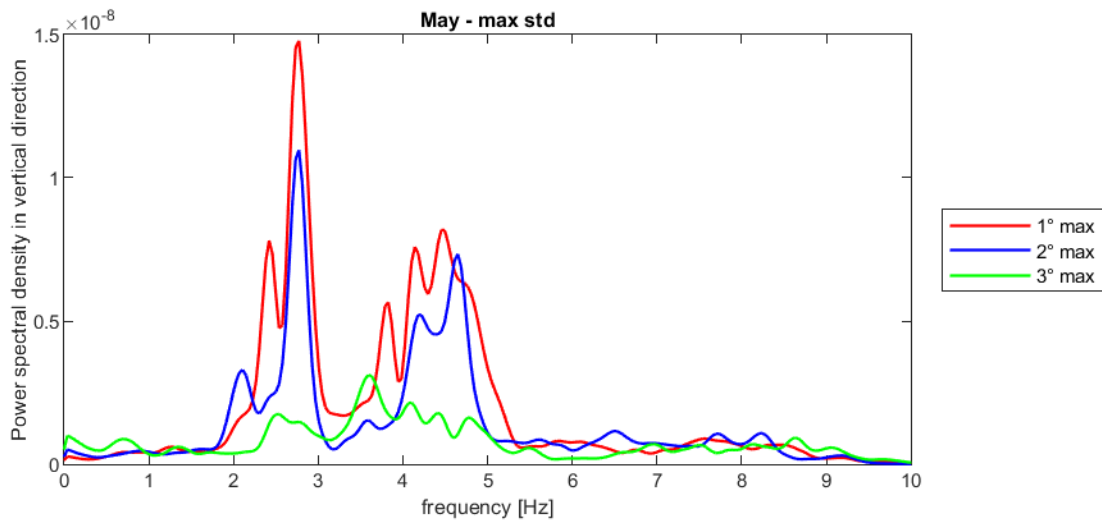

Figure 0-50: Results obtained from the 3 accelerograms with maximum SD in time domain

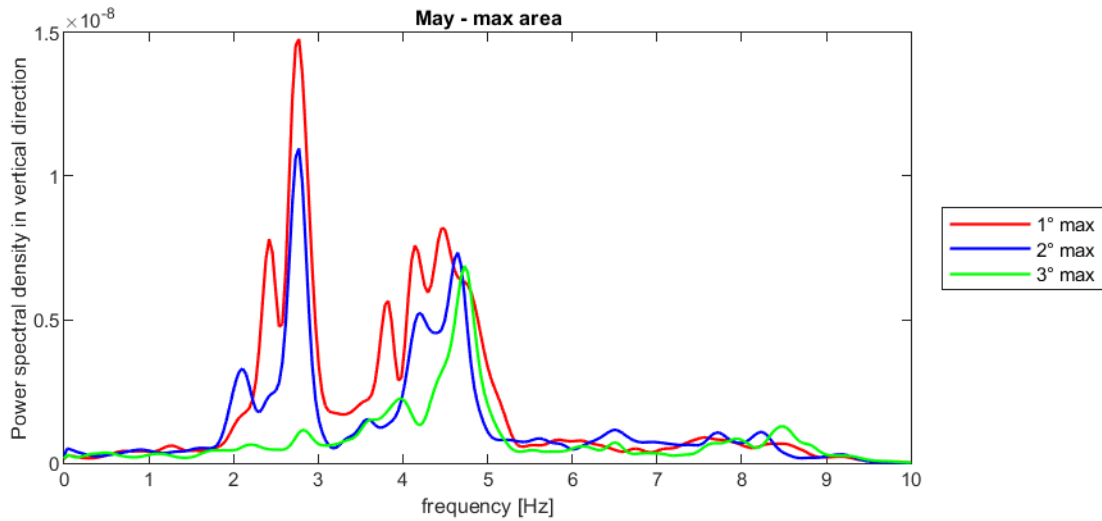

Figure 0-51: Results obtained from the 3 accelerograms with maximum area of PSD

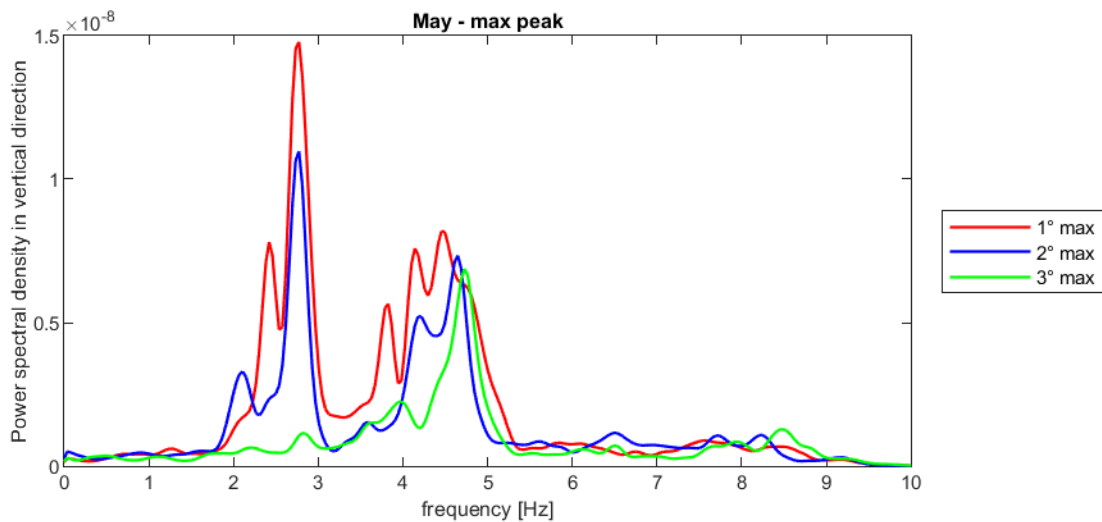

Figure 0-52: Results obtained from the 3 accelerograms with highest peak if PSD

Monitoring activity on Fiorenza Node of A4 Highway

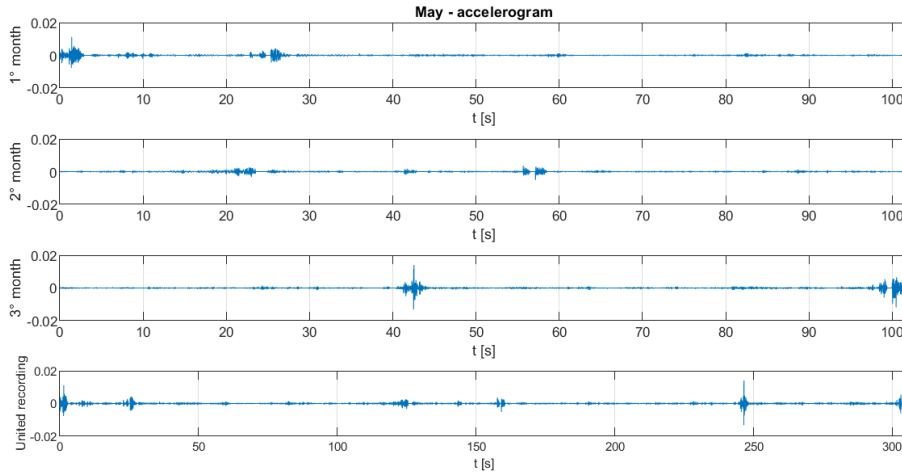

Figure 0-53: Accelerograms in vertical (x) direction with maximum standard deviation in time domain

10.5.2 Longitudinal direction (y)

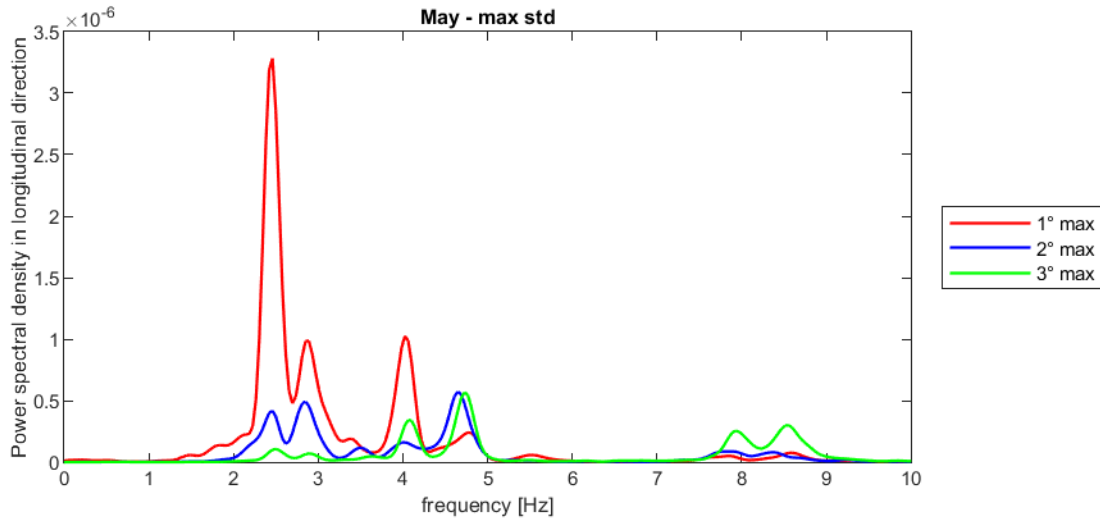

Figure 0-54: Results obtained from the 3 accelerograms with maximum SD in time domain

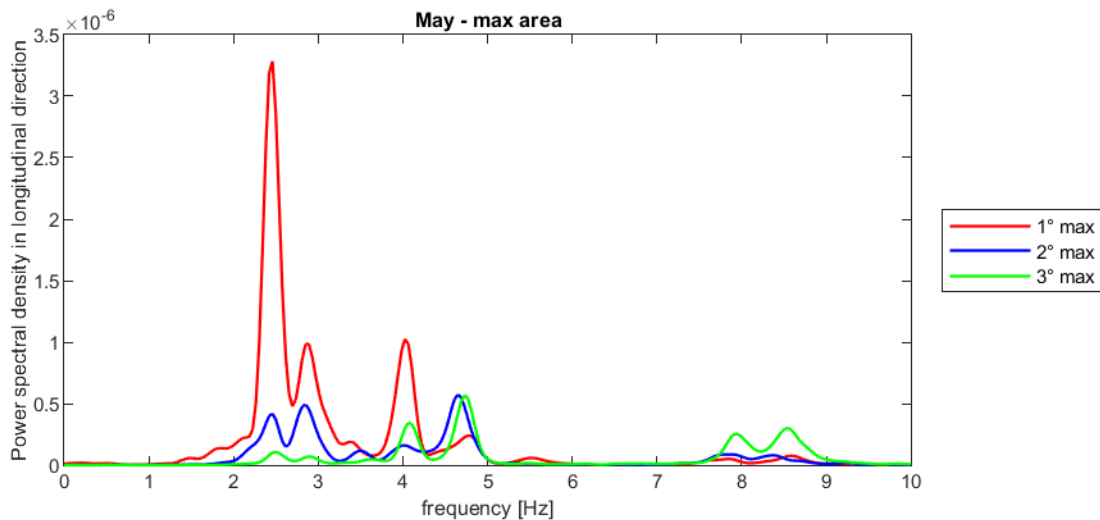

Figure 0-55: Results obtained from the 3 accelerograms with maximum area of PSD

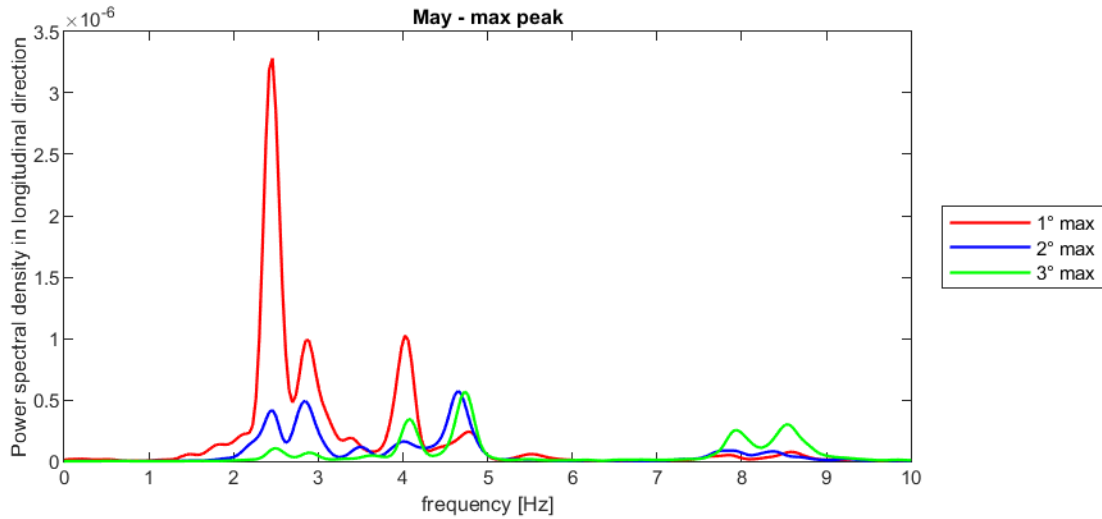

Figure 0-56: Results obtained from the 3 accelerograms with highest peak if PSD

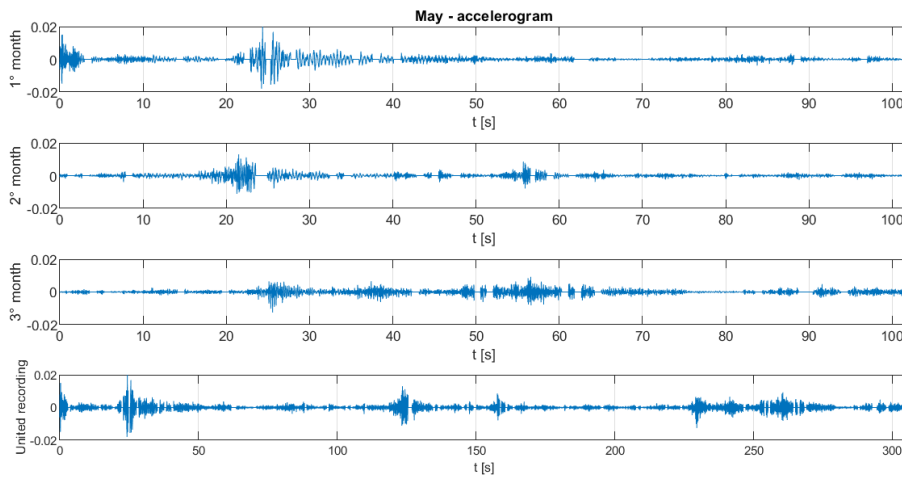

Figure 0-57: Accelerograms in longitudinal (y) direction with maximum standard deviation in time domain

10.5.3 Transverse direction (z)

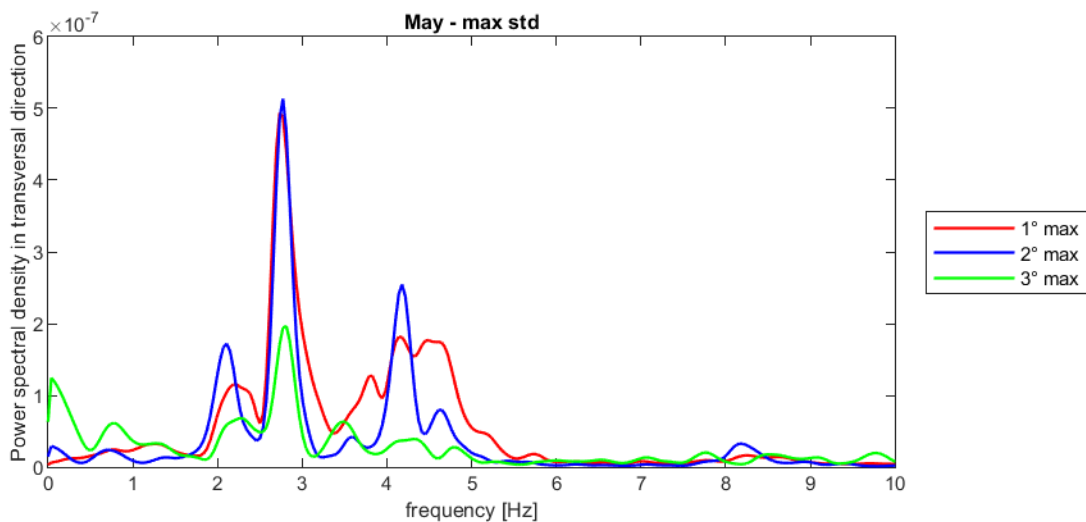

Figure 0-58: Results obtained from the 3 accelerograms with maximum SD in time domain

Monitoring activity on Fiorenza Node of A4 Highway

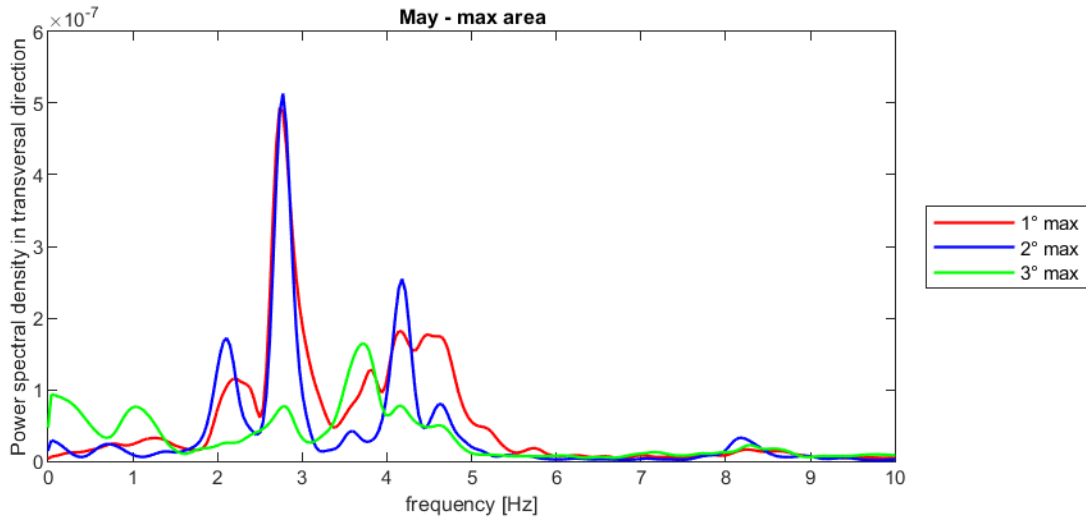

Figure 0-59: Results obtained from the 3 accelerograms with maximum area of PSD

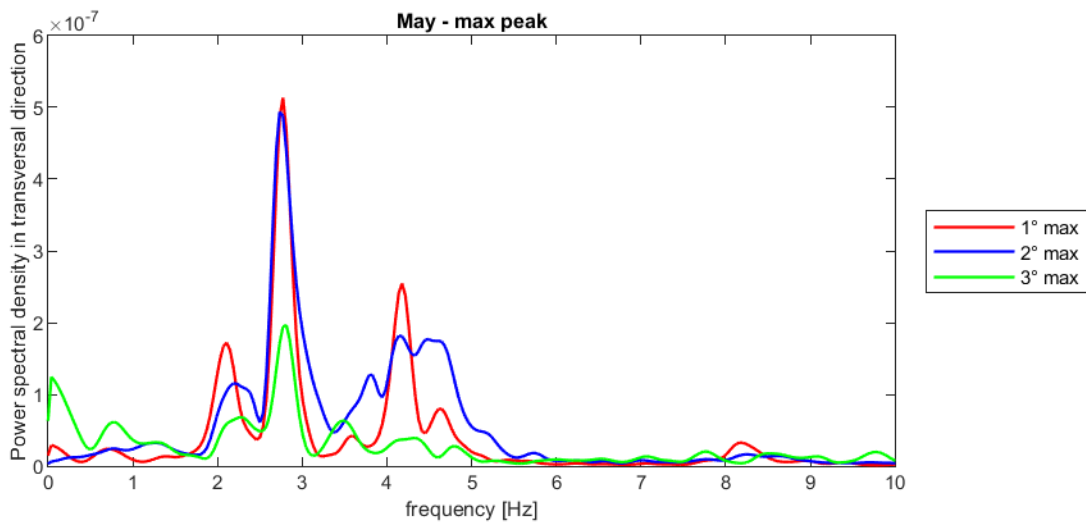

Figure 0-60: Results obtained from the 3 accelerograms with highest peak if PSD

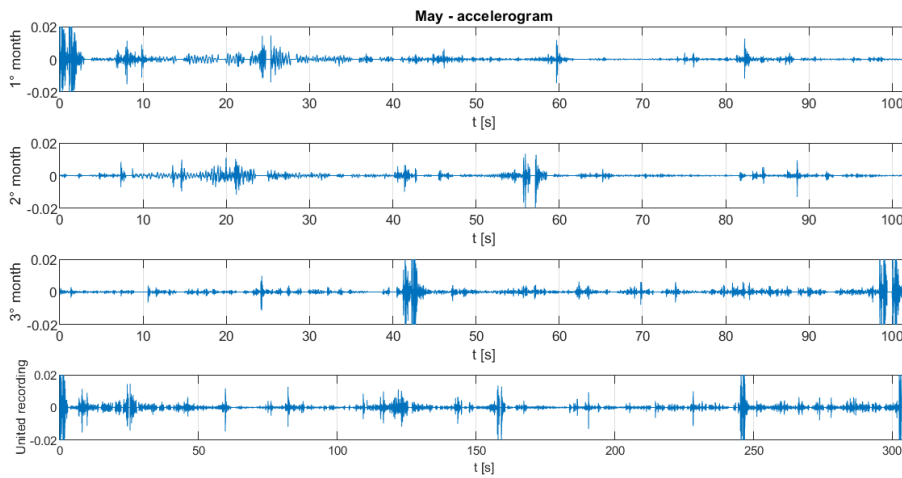

Figure 0-61: Accelerograms in transverse (z) direction with maximum standard deviation in time domain

10.6 June

The results obtained for the June dataset are shown in the following tables.

Table 0-16: June 2023 - Accelerograms with the maximum standard deviation

	#	Accelerogram	Standard deviation
Vertical direction (x)	1°	319E3_2023-06-10_08-00-21	1.27E-04
	2°	319E3_2023-06-08_08-00-21	1.12E-04
	3°	319E3_2023-06-13_08-00-20	1.08E-04
Longitudinal direction (y)	1°	319E3_2023-06-10_08-00-21	1.07E-03
	2°	319E3_2023-06-21_08-00-21	8.65E-04
	3°	319E3_2023-06-13_08-00-20	7.68E-04
Transverse direction (z)	1°	319E3_2023-06-10_08-00-21	7.69E-04
	2°	319E3_2023-06-21_08-00-21	5.68E-04
	3°	319E3_2023-06-13_08-00-20	5.46E-04

Table 0-17: June 2023 - Accelerograms defined by the maximum area and peak of the power spectral density function

Vertical direction (x)				
#	Accelerogram	Peak value	Accelerogram	Area
1	319E3_2023-06-10_08-00-21	1.33E-08	319E3_2023-06-10_08-00-21	3.50E-09
2	319E3_2023-06-13_08-00-20	1.04E-08	319E3_2023-06-08_08-00-21	2.55E-09
3	319E3_2023-06-21_08-00-21	9.50E-09	319E3_2023-06-13_08-00-20	2.36E-09
Longitudinal direction (y)				
	Accelerogram	Peak value	Accelerogram	Area
1	319E3_2023-06-21_08-00-21	1.45E-06	319E3_2023-06-10_08-00-21	2.29E-07
2	319E3_2023-06-10_08-00-21	1.24E-06	319E3_2023-06-21_08-00-21	1.60E-07
3	319E3_2023-06-15_08-00-20	5.15E-07	319E3_2023-06-13_08-00-20	1.21E-07
Transverse direction (z)				
	Accelerogram	Peak value	Accelerogram	Area
1	319E3_2023-06-10_08-00-21	8.30E-07	319E3_2023-06-10_08-00-21	1.21E-07
2	319E3_2023-06-13_08-00-20	4.21E-07	319E3_2023-06-21_08-00-21	6.85E-08
3	319E3_2023-06-21_08-00-21	3.86E-07	319E3_2023-06-13_08-00-20	5.97E-08

Table 0-18: June 2023 – Statistical analysis

	Vertical X			Longitudinal Y			Transverse Z		
	Std	Peak	Area	Std	Peak	Area	Std	Peak	Area
1	A	A	A	A	D	A	A	A	A
2	B	C	B	D	A	D	D	C	D
3	C	-	C	C	-	C	C	D	C

10.6.1 Vertical direction (x)

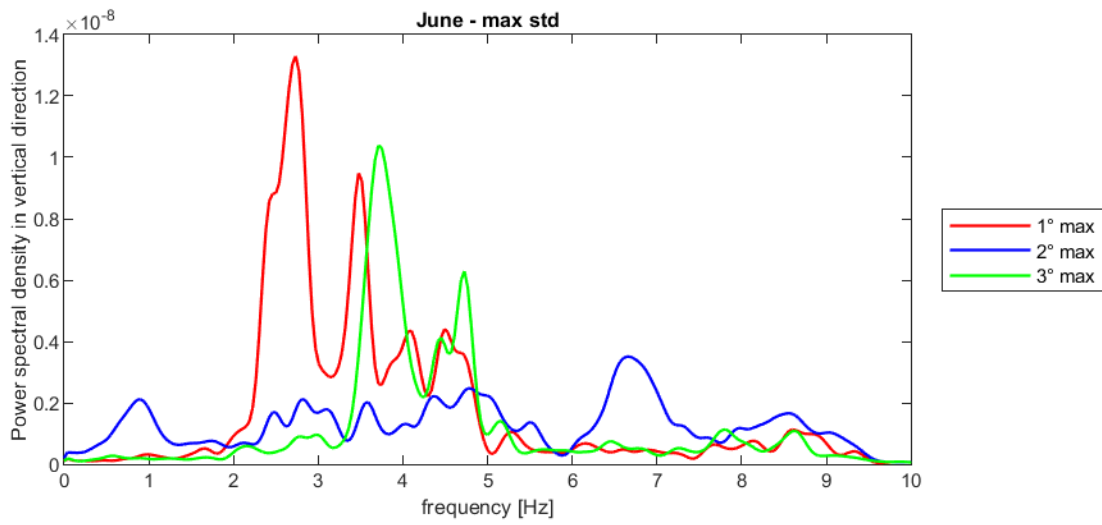

Figure 0-62: Results obtained from the 3 accelerograms with maximum SD in time domain

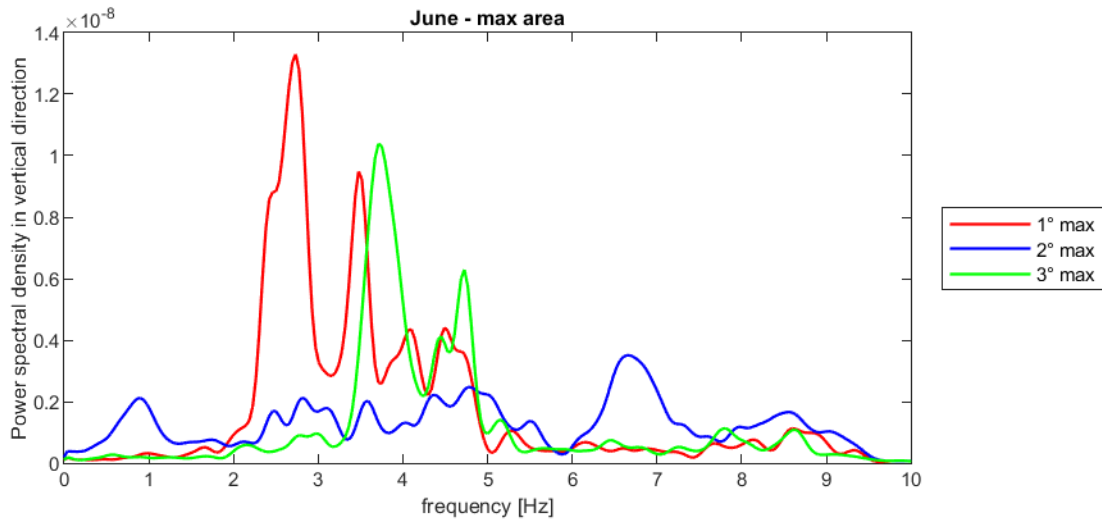

Figure 0-63: Results obtained from the 3 accelerograms with maximum area of PSD

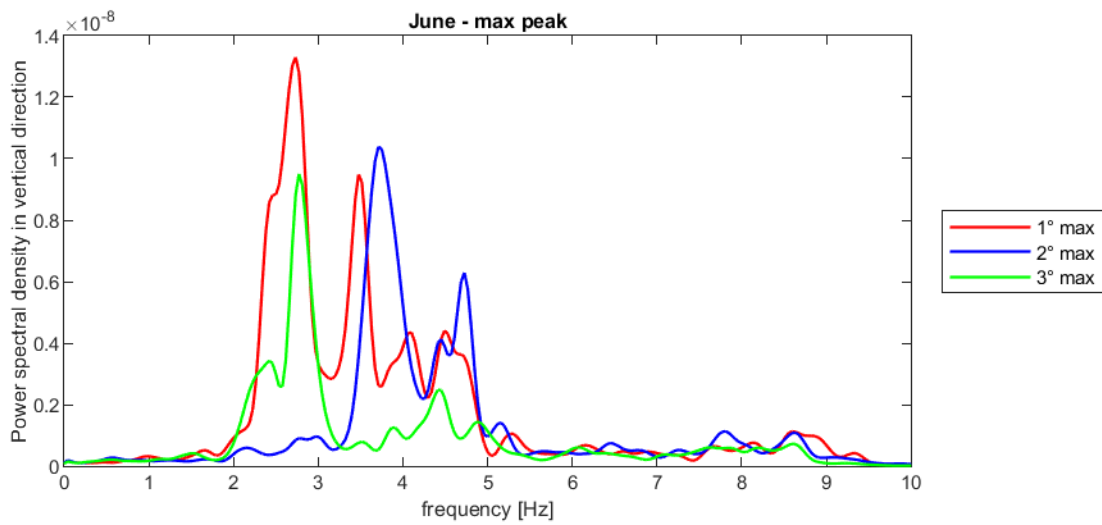

Figure 0-64: Results obtained from the 3 accelerograms with highest peak if PSD

Monitoring activity on Firenze Node of A4 Highway

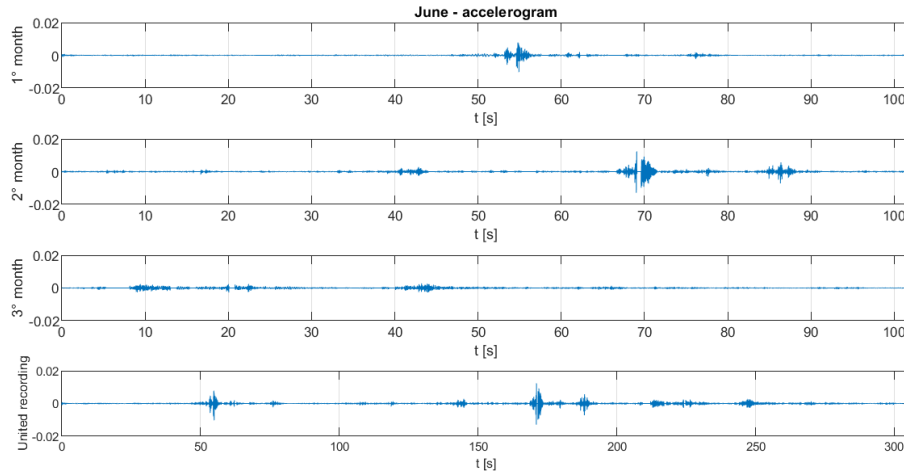

Figure 0-65: Accelerograms in vertical (x) direction with maximum standard deviation in time domain

10.6.2 Longitudinal direction (y)

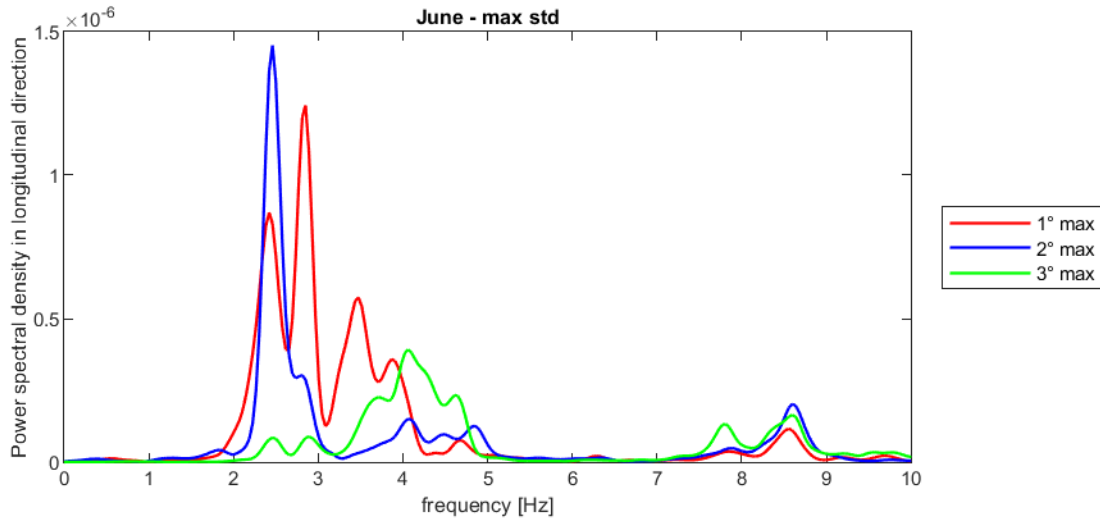

Figure 0-66: Results obtained from the 3 accelerograms with maximum SD in time domain

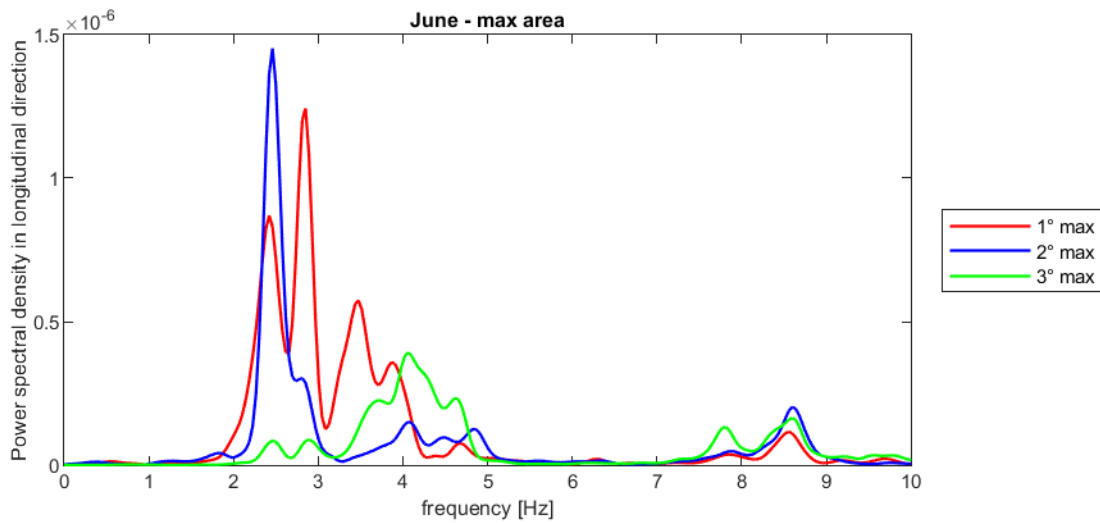

Figure 0-67: Results obtained from the 3 accelerograms with maximum area of PSD

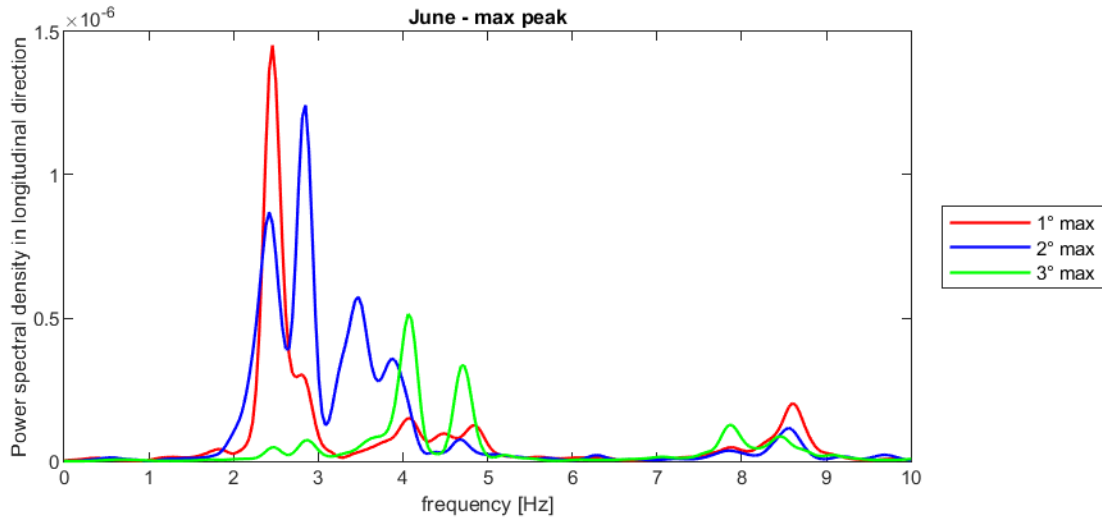

Figure 0-68: Results obtained from the 3 accelerograms with highest peak if PSD

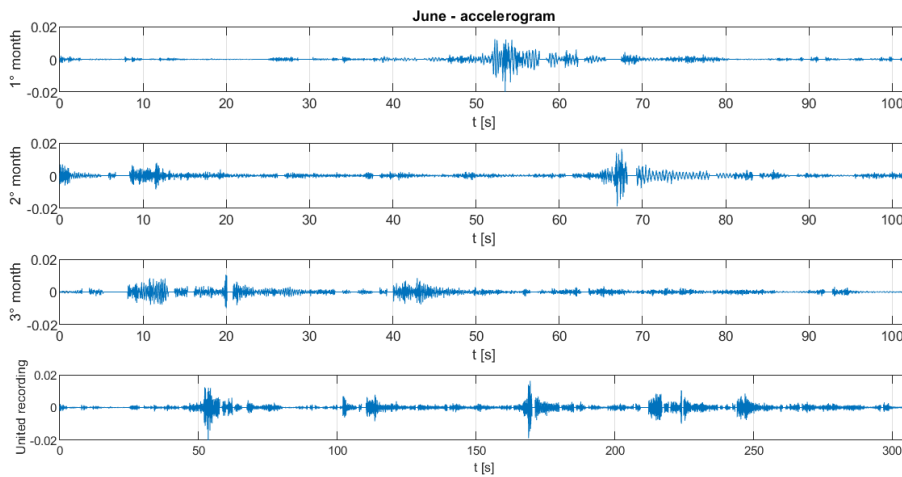

Figure 0-69: Accelerograms in longitudinal (y) direction with maximum standard deviation in time domain

10.6.3 Transverse direction (z)

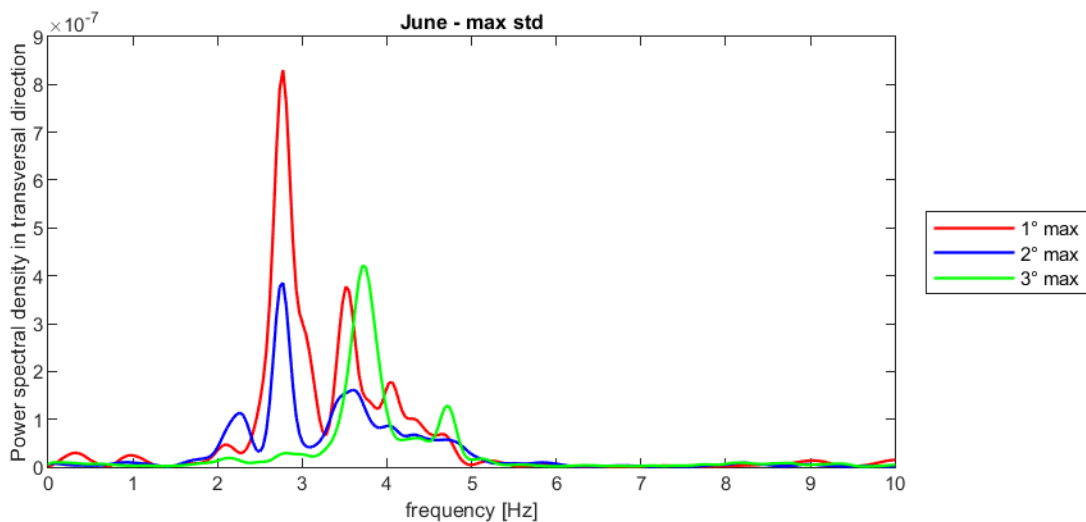

Figure 0-70: Results obtained from the 3 accelerograms with maximum SD in time domain

Monitoring activity on Fiorenza Node of A4 Highway

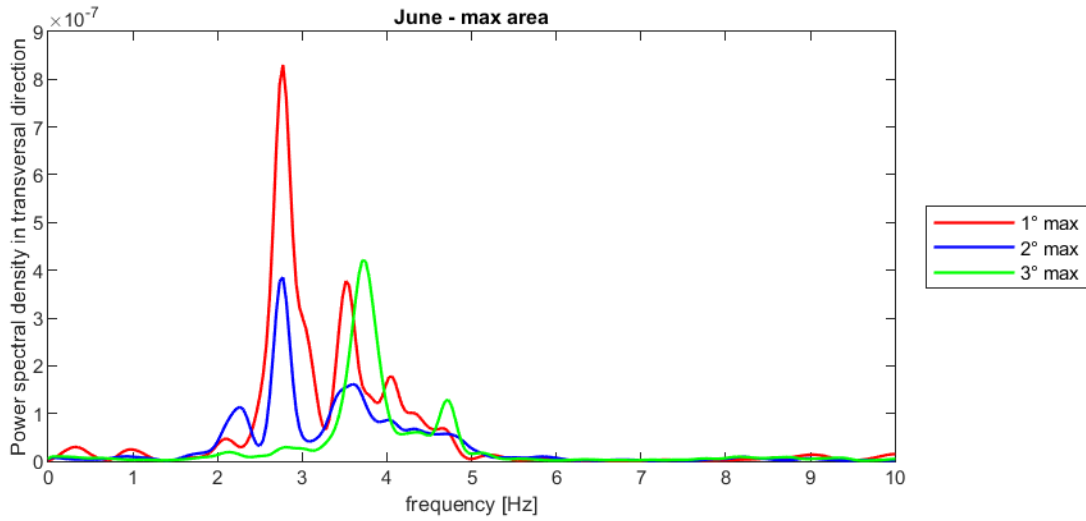

Figure 0-71: Results obtained from the 3 accelerograms with maximum area of PSD

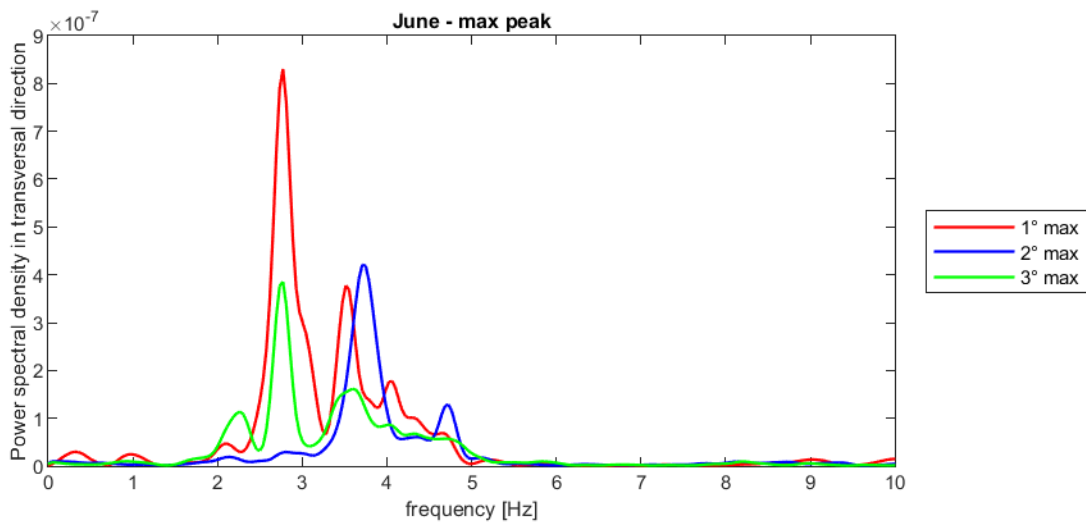

Figure 0-72: Results obtained from the 3 accelerograms with highest peak if PSD

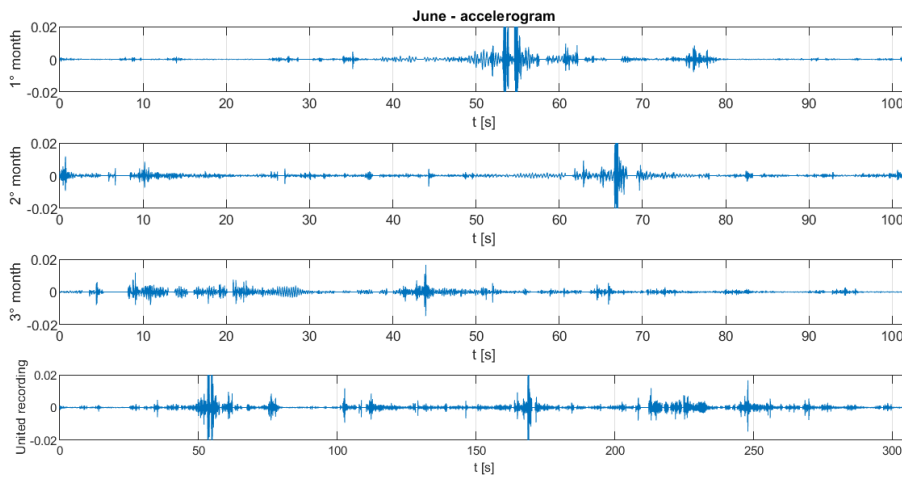

Figure 0-73: Accelerograms in transverse (z) direction with maximum standard deviation in time domain

10.7 July

The results obtained for the July dataset are shown in the following tables.

Table 0-19: July 2023 - Accelerograms with the maximum standard deviation

	#	Accelerogram	Standard deviation
Vertical direction (x)	1°	319E3_2023-07-06_14-00-21	1.22E-04
	2°	319E3_2023-07-07_14-00-21	1.15E-04
	3°	319E3_2023-07-22_14-00-21	9.75E-05
Longitudinal direction (y)	1°	319E3_2023-07-06_14-00-21	9.84E-04
	2°	319E3_2023-07-07_14-00-21	8.56E-04
	3°	319E3_2023-07-20_14-00-21	8.19E-04
Transverse direction (z)	1°	319E3_2023-07-06_14-00-21	8.44E-04
	2°	319E3_2023-07-07_14-00-21	7.07E-04
	3°	319E3_2023-07-22_14-00-21	6.42E-04

Table 0-20: July 2023 - Accelerograms defined by the maximum area and peak of the power spectral density function

Vertical direction (x)				
#	Accelerogram	Peak value	Accelerogram	Area
1	319E3_2023-07-07_14-00-21	1.52E-08	319E3_2023-07-06_14-00-21	3.05E-09
2	319E3_2023-07-06_14-00-21	1.15E-08	319E3_2023-07-07_14-00-21	2.68E-09
3	319E3_2023-07-17_14-00-20	4.78E-09	319E3_2023-07-22_14-00-21	1.87E-09
Longitudinal direction (y)				
	Accelerogram	Peak value	Accelerogram	Area
1	319E3_2023-07-17_14-00-20	8.24E-07	319E3_2023-07-06_14-00-21	1.75E-07
2	319E3_2023-07-06_14-00-21	7.92E-07	319E3_2023-07-07_14-00-21	1.40E-07
3	319E3_2023-07-20_14-00-21	7.37E-07	319E3_2023-07-20_14-00-21	1.32E-07
Transverse direction (z)				
	Accelerogram	Peak value	Accelerogram	Area
1	319E3_2023-07-06_14-00-21	8.51E-07	319E3_2023-07-06_14-00-21	1.46E-07
2	319E3_2023-07-07_14-00-21	5.46E-07	319E3_2023-07-07_14-00-21	1.01E-07
3	319E3_2023-07-19_08-00-20	3.21E-07	319E3_2023-07-22_14-00-21	8.20E-08

Table 0-21: July 2023 – Statistical analysis

	Vertical X			Longitudinal Y			Transverse Z		
	Std	Peak	Area	Std	Peak	Area	Std	Peak	Area
1	A	B	A	A	-	A	A	A	A
2	B	A	B	B	A	B	B	B	B
3	C	-	C	D	D	D	C	-	C

10.7.1 Vertical direction (x)

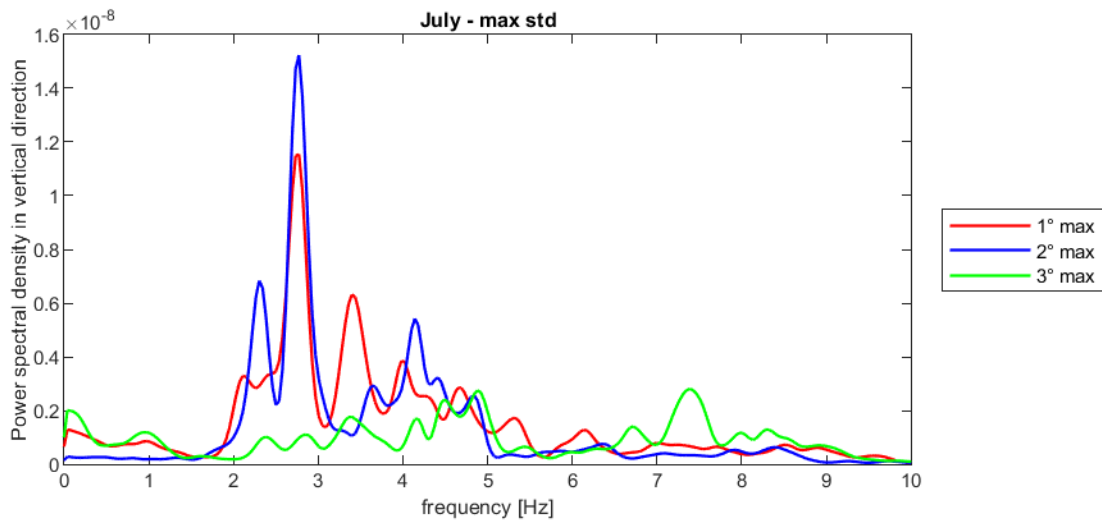

Figure 0-74: Results obtained from the 3 accelerograms with maximum SD in time domain

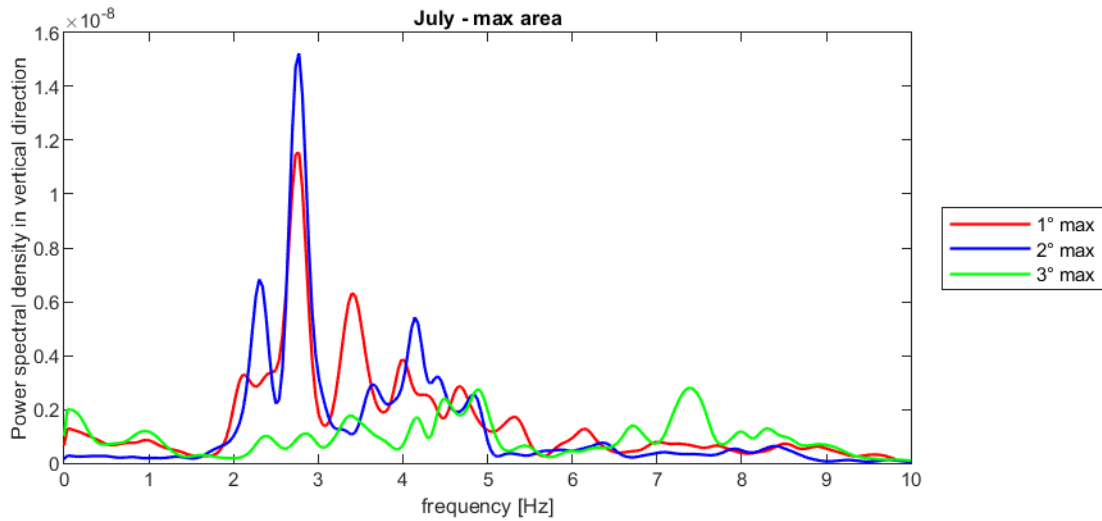

Figure 0-75: Results obtained from the 3 accelerograms with maximum area of PSD

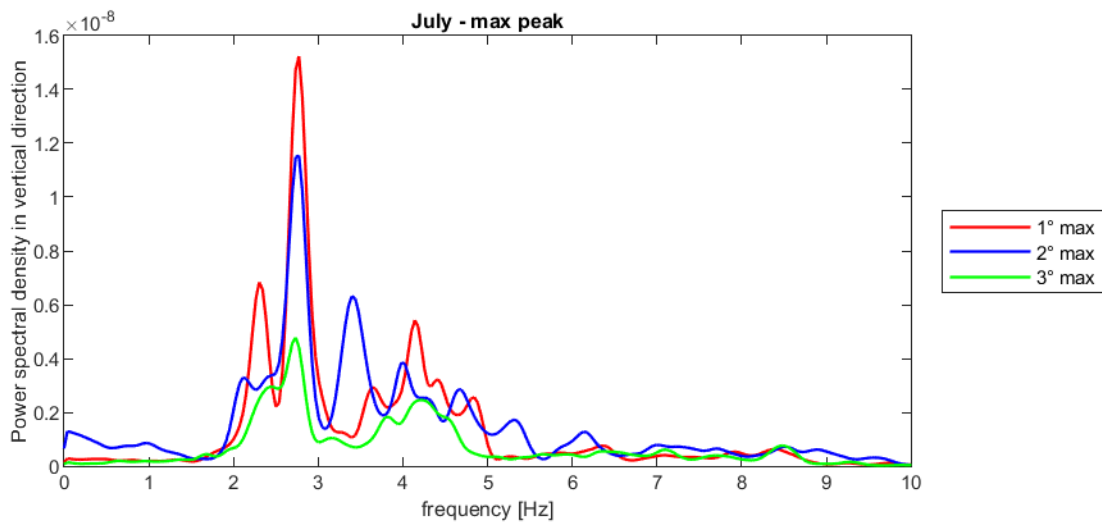

Figure 0-76: Results obtained from the 3 accelerograms with highest peak if PSD

Monitoring activity on Fiorenza Node of A4 Highway

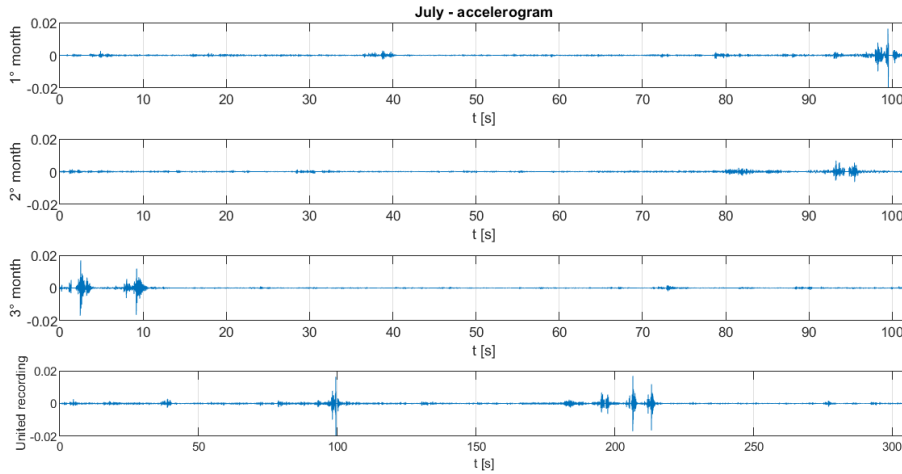

Figure 0-77: Accelerograms in vertical (x) direction with maximum standard deviation in time domain

10.7.2 Longitudinal direction (y)

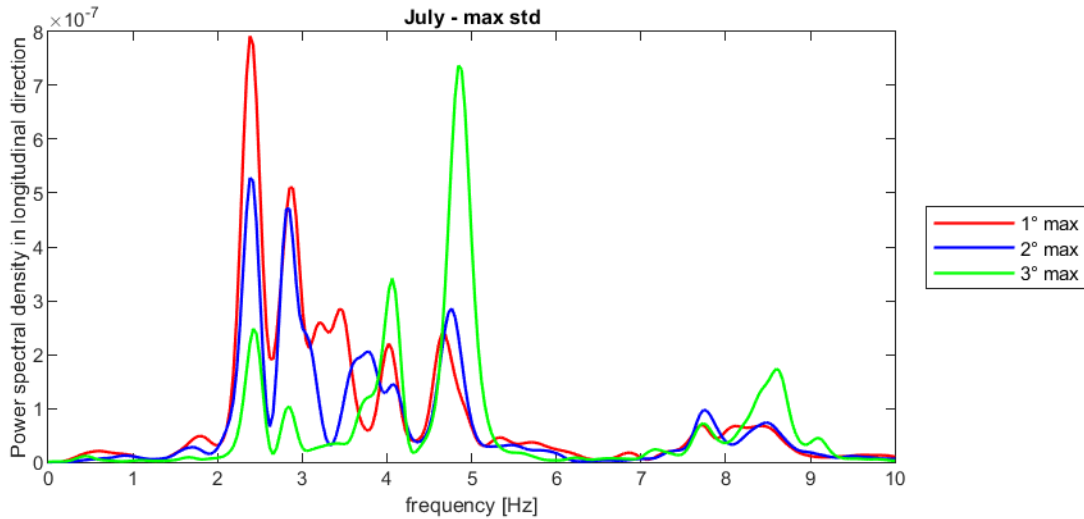

Figure 0-78: Results obtained from the 3 accelerograms with maximum SD in time domain

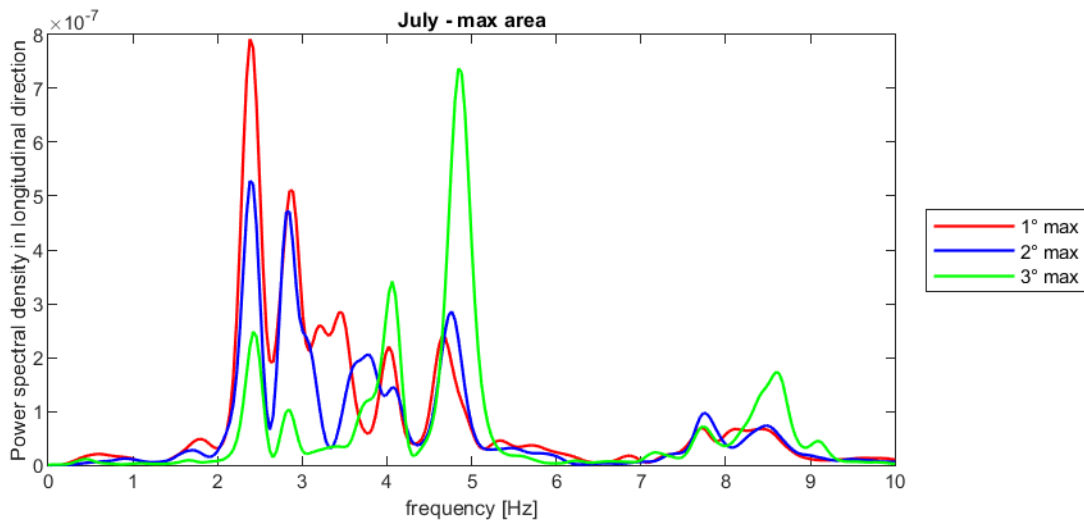

Figure 0-79: Results obtained from the 3 accelerograms with maximum area of PSD

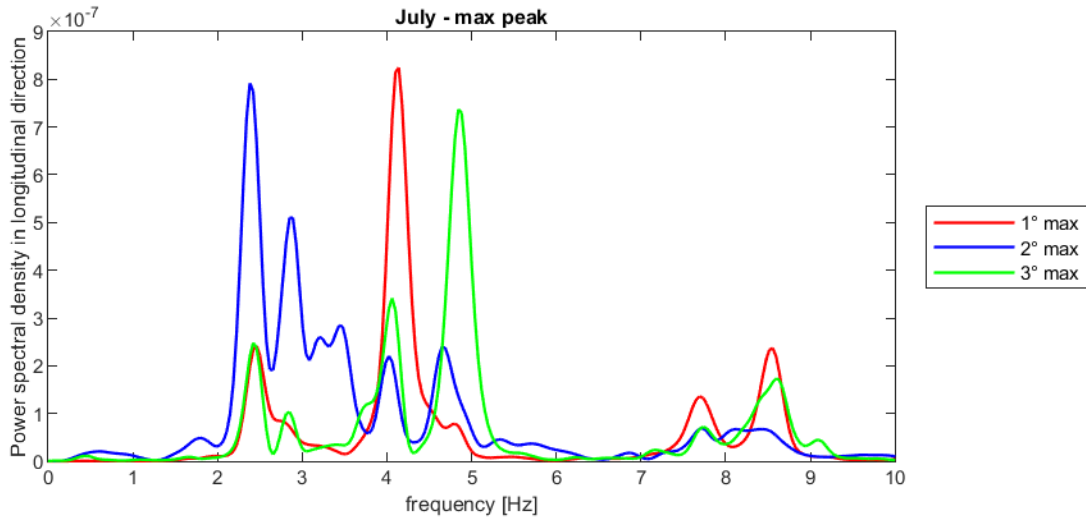

Figure 0-80: Results obtained from the 3 accelerograms with highest peak if PSD

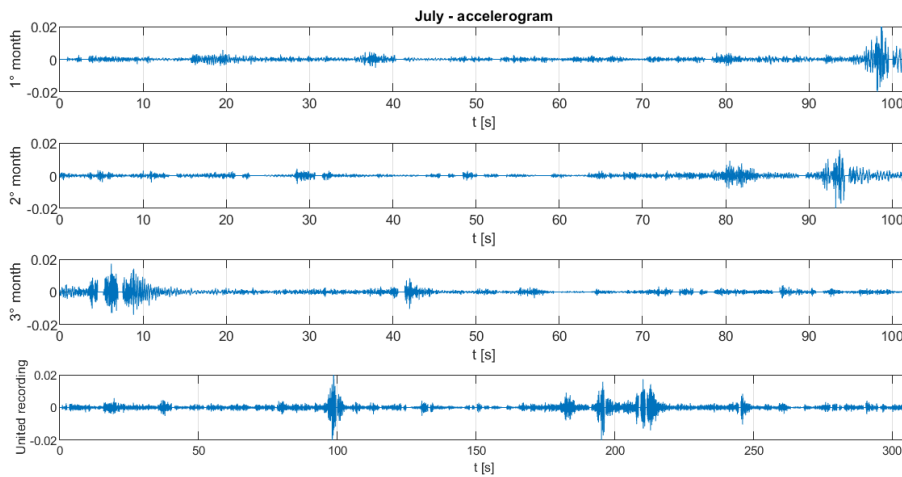

Figure 0-81: Accelerograms in vertical (x) direction with maximum standard deviation in time domain

10.7.3 Transverse direction (z)

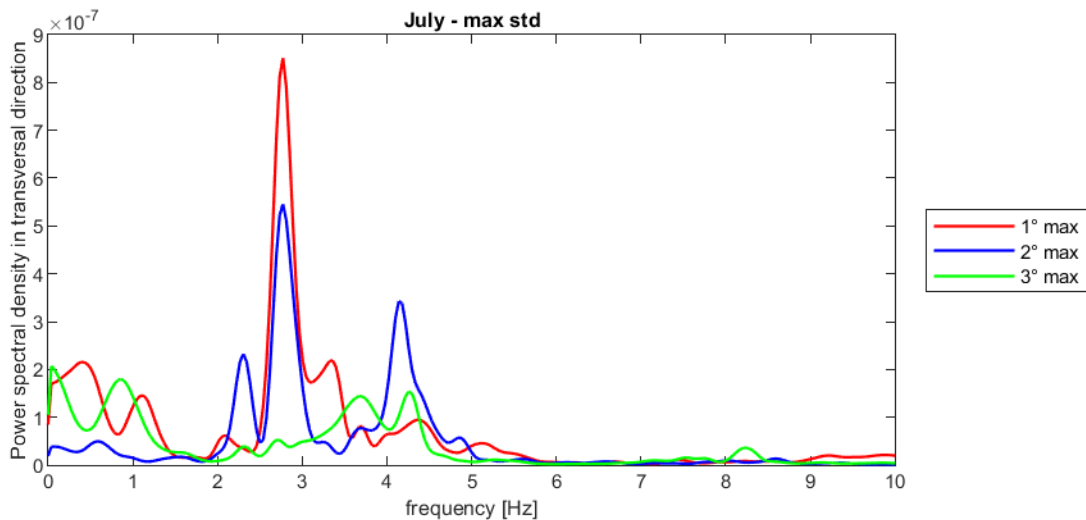

Figure 0-82: Results obtained from the 3 accelerograms with maximum SD in time domain

Monitoring activity on Fiorenza Node of A4 Highway

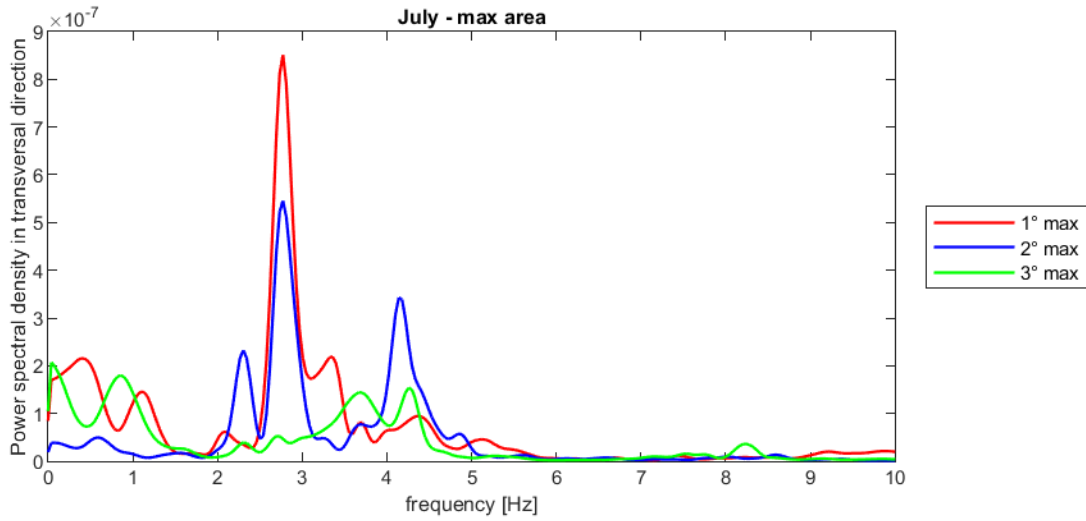

Figure 0-83: Results obtained from the 3 accelerograms with maximum area of PSD

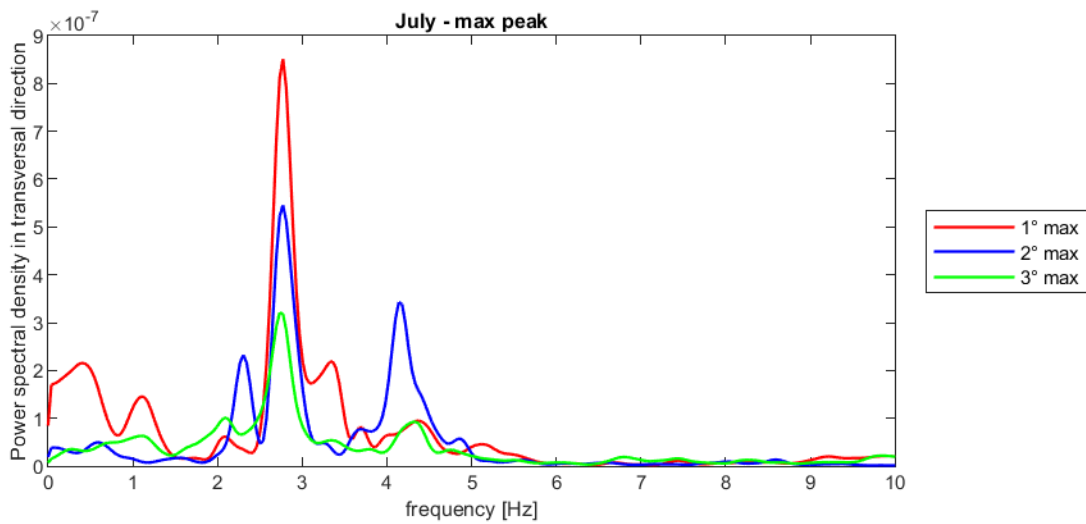

Figure 0-84: Results obtained from the 3 accelerograms with highest peak if PSD

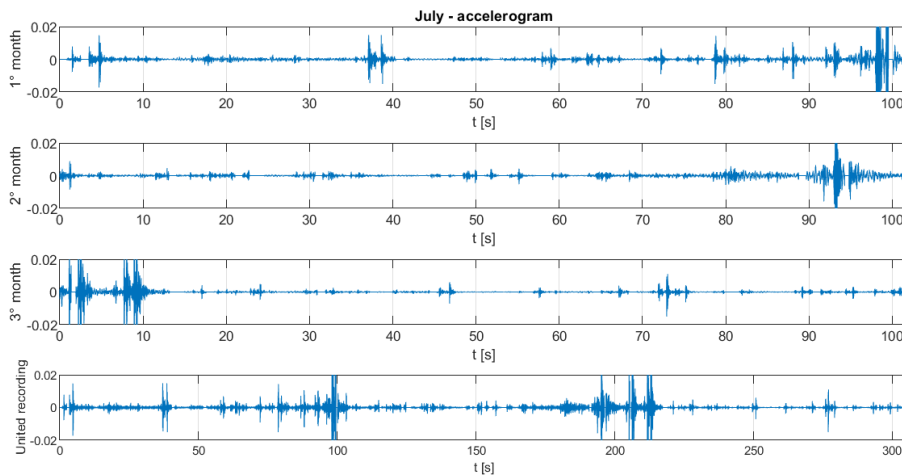

Figure 0-85: Accelerograms in transversal (z) direction with maximum standard deviation in time domain

10.8 August

The results obtained for the August dataset are shown in the following tables.

Table 0-22: August 2023 - Accelerograms with the maximum standard deviation

	#	Accelerogram	Standard deviation
Vertical direction (x)	1°	319E3_2023-08-02_08-00-20	1.13E-04
	2°	319E3_2023-08-07_14-00-20	1.10E-04
	3°	319E3_2023-08-02_20-00-20	1.01E-04
Longitudinal direction (y)	1°	319E3_2023-08-07_14-00-20	8.03E-04
	2°	319E3_2023-08-02_08-00-20	6.97E-04
	3°	319E3_2023-08-30_08-00-21	6.43E-04
Transverse direction (z)	1°	319E3_2023-08-02_20-00-20	6.18E-04
	2°	319E3_2023-08-07_14-00-20	6.13E-04
	3°	319E3_2023-08-10_08-00-20	5.28E-04

Table 0-23: August 2023 - Accelerograms defined by the maximum area and peak of the power spectral density function

Vertical direction (x)				
#	Accelerogram	Peak value	Accelerogram	Area
1	319E3_2023-08-07_14-00-20	1.72E-08	319E3_2023-08-07_14-00-20	2.48E-09
2	319E3_2023-08-10_08-00-20	5.74E-09	319E3_2023-08-02_20-00-20	2.43E-09
3	319E3_2023-08-30_08-00-21	5.24E-09	319E3_2023-08-02_08-00-20	2.33E-09
Longitudinal direction (y)				
	Accelerogram	Peak value	Accelerogram	Area
1	319E3_2023-08-07_14-00-20	7.81E-07	319E3_2023-08-07_14-00-20	1.32E-07
2	319E3_2023-08-10_08-00-20	6.28E-07	319E3_2023-08-02_08-00-20	9.95E-08
3	319E3_2023-08-07_08-00-21	5.68E-07	319E3_2023-08-30_08-00-21	8.77E-08
Transverse direction (z)				
	Accelerogram	Peak value	Accelerogram	Area
1	319E3_2023-08-07_14-00-20	4.95E-07	319E3_2023-08-02_20-00-20	9.20E-08
2	319E3_2023-08-10_08-00-20	2.65E-07	319E3_2023-08-07_14-00-20	7.55E-08
3	319E3_2023-08-03_08-00-21	1.82E-07	319E3_2023-08-03_08-00-21	5.66E-08

Table 0-24: August 2023 – Statistical analysis

	Vertical X			Longitudinal Y			Transverse Z		
	Std	Peak	Area	Std	Peak	Area	Std	Peak	Area
1	A	B	B	B	B	B	C	B	C
2	B	-	C	A	-	A	B	E	B
3	C	-	A	D	-	D	E	F	F

10.8.1 Vertical direction (x)

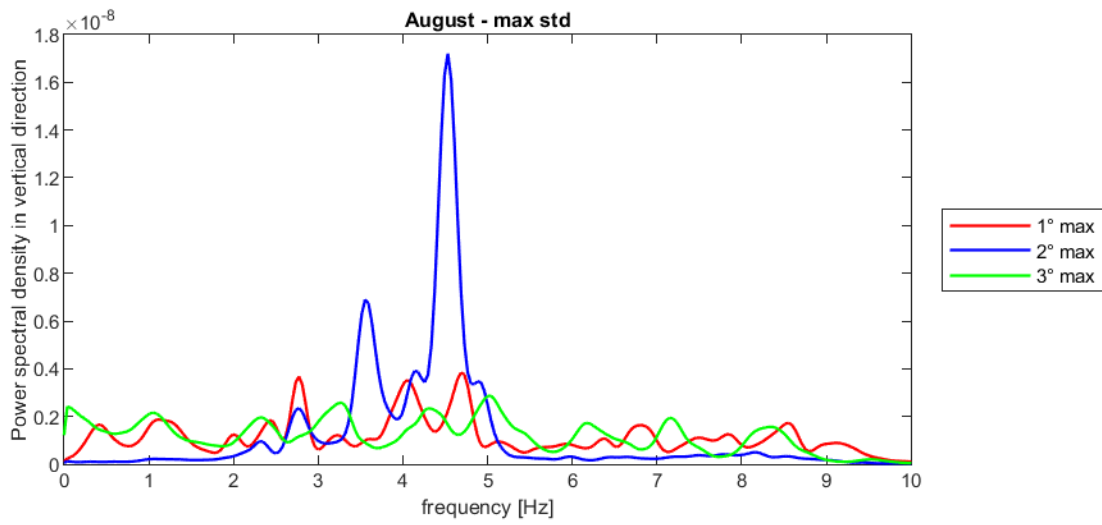

Figure 0-86: Results obtained from the 3 accelerograms with maximum SD in time domain

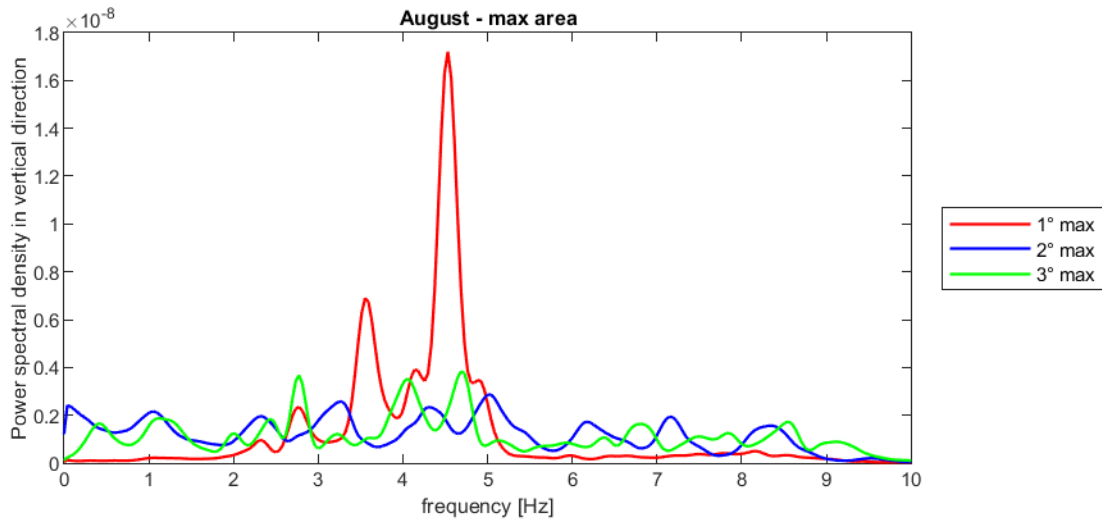

Figure 0-87: Results obtained from the 3 accelerograms with maximum area of PSD

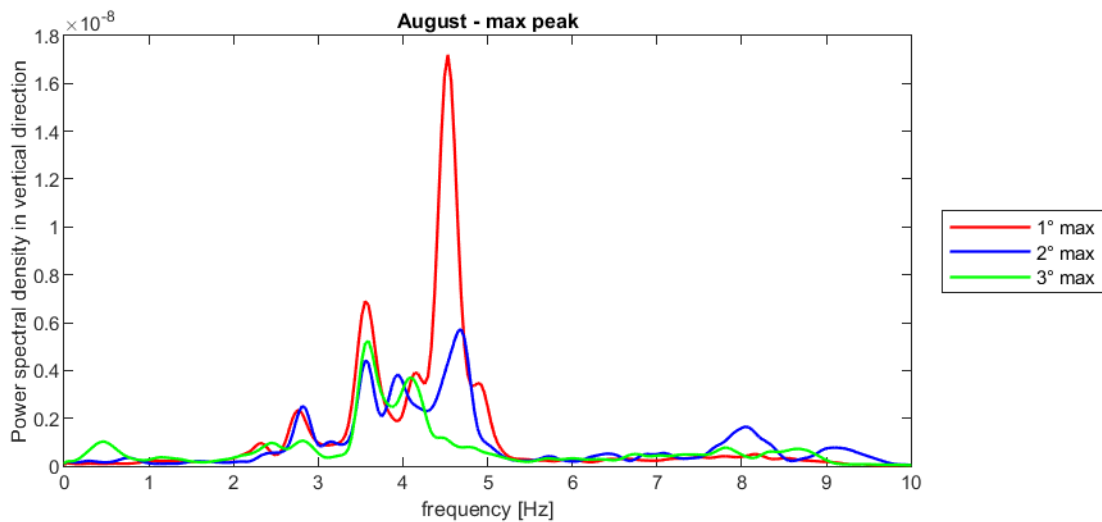

Figure 0-88: Results obtained from the 3 accelerograms with highest peak if PSD

Monitoring activity on Firenze Node of A4 Highway

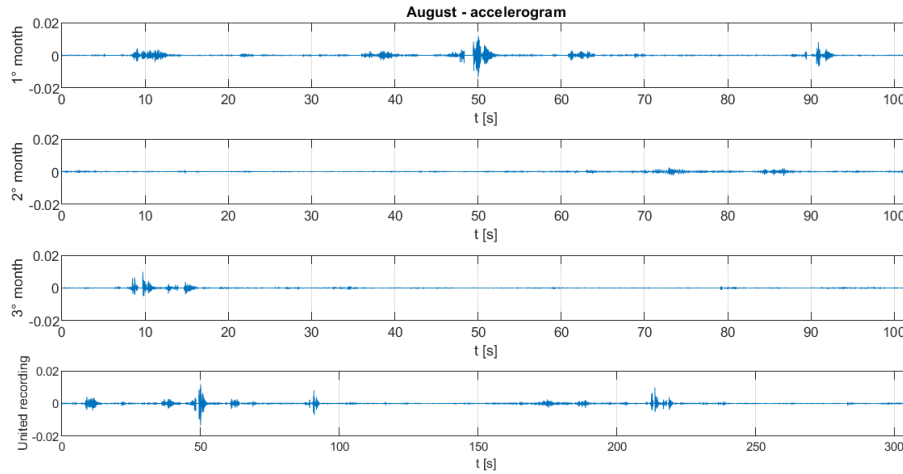

Figure 0-89: Accelerograms in vertical (x) direction with maximum standard deviation in time domain

10.8.2 Longitudinal direction (y)

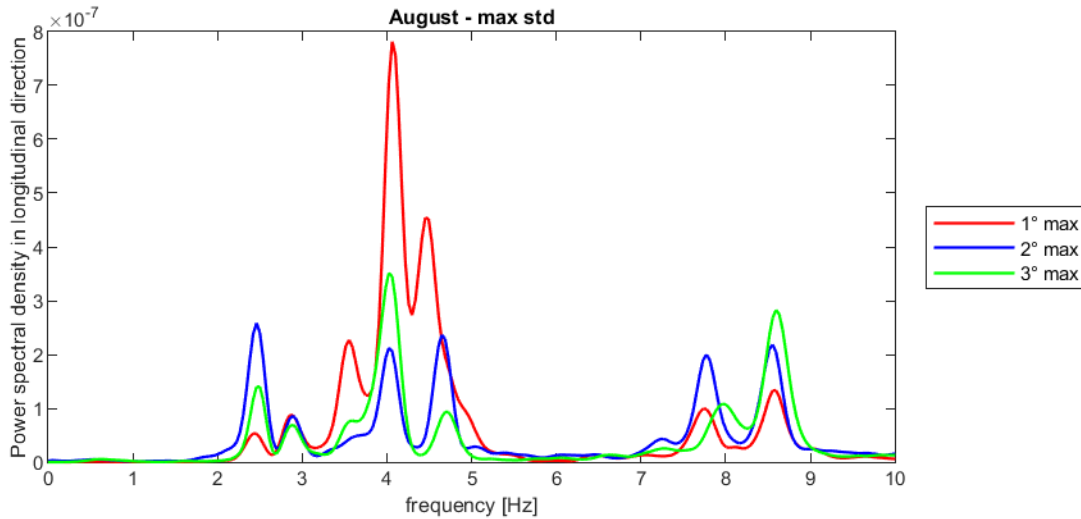

Figure 0-90: Results obtained from the 3 accelerograms with maximum SD in time domain

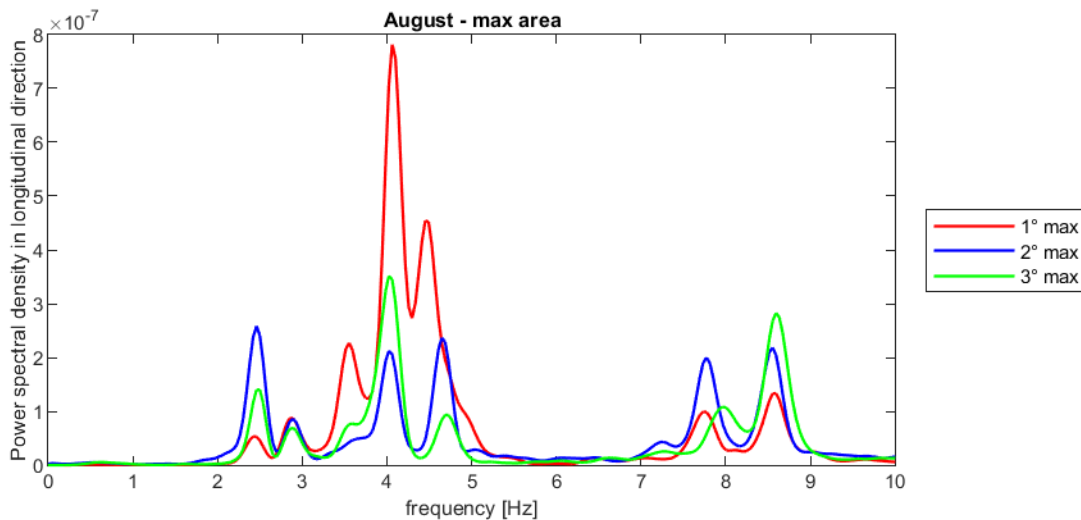

Figure 0-91: Results obtained from the 3 accelerograms with maximum area of PSD

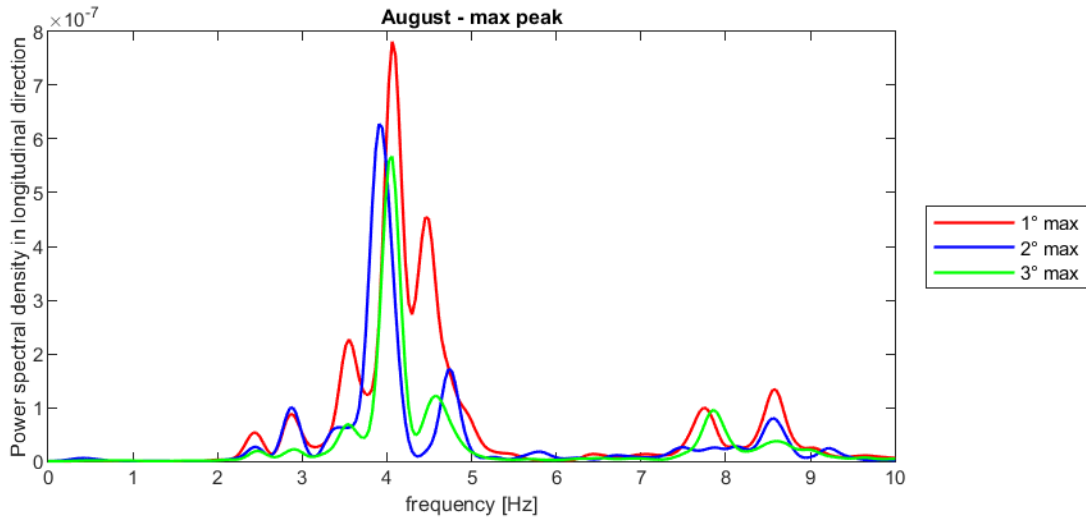

Figure 0-92: Results obtained from the 3 accelerograms with highest peak if PSD

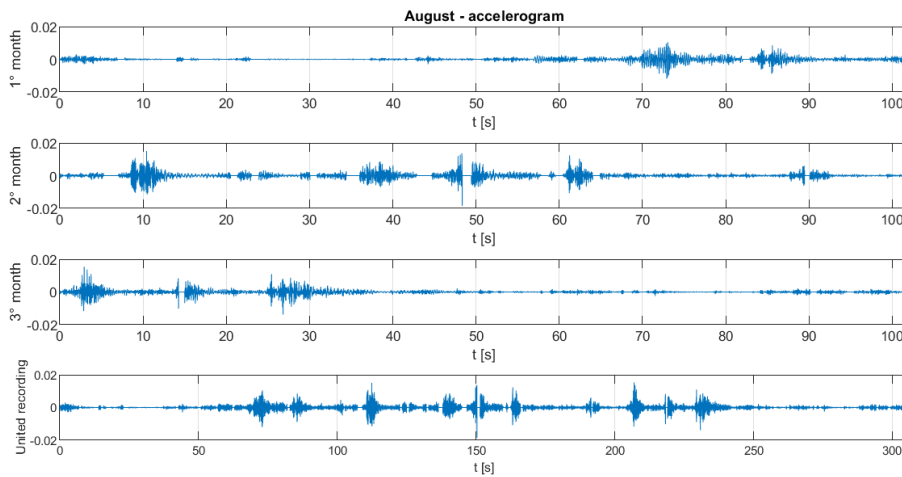

Figure 0-93: Accelerograms in longitudinal (y) direction with maximum standard deviation in time domain

10.8.3 Transverse direction (z)

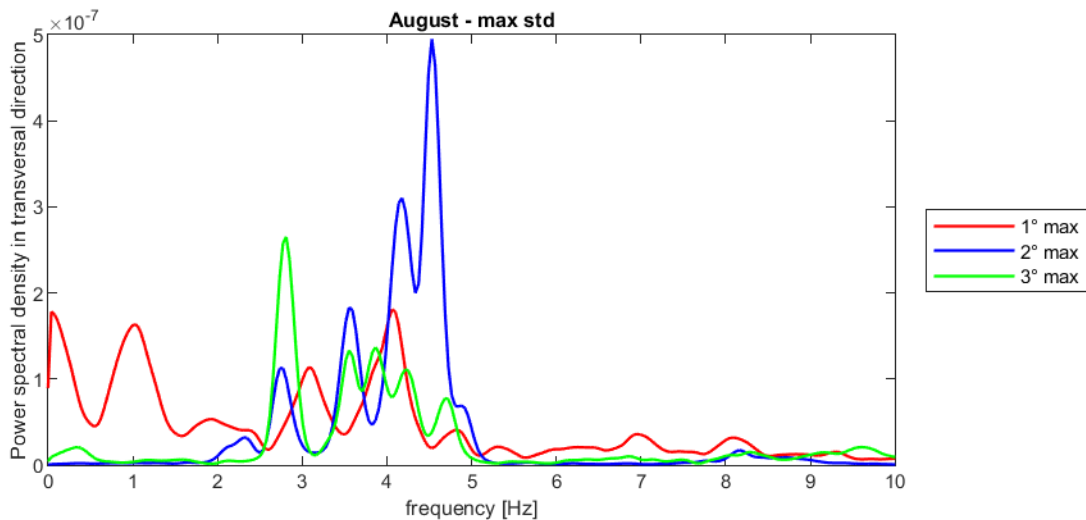

Figure 0-94: Results obtained from the 3 accelerograms with maximum SD in time domain

Monitoring activity on Fiorenza Node of A4 Highway

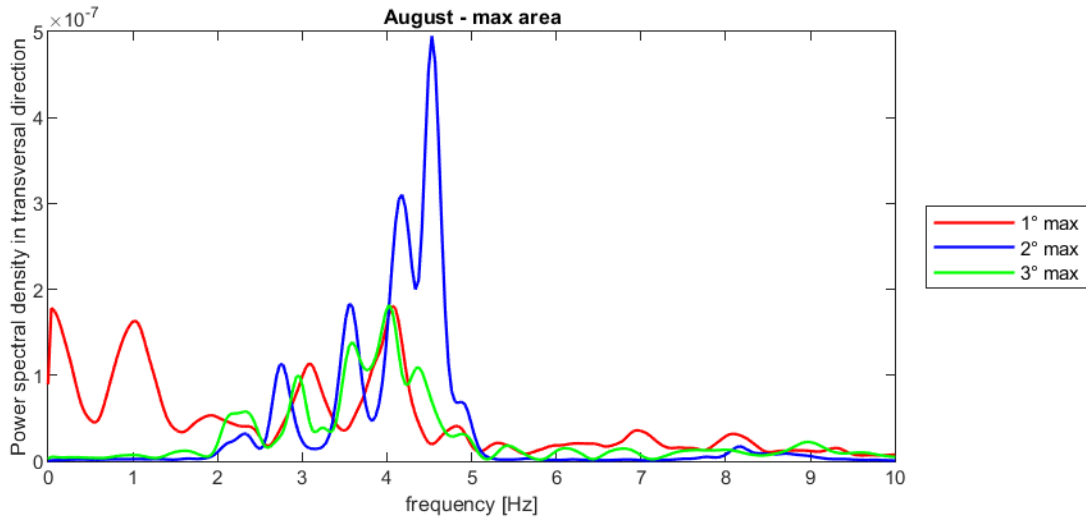

Figure 0-95: Results obtained from the 3 accelerograms with maximum area of PSD

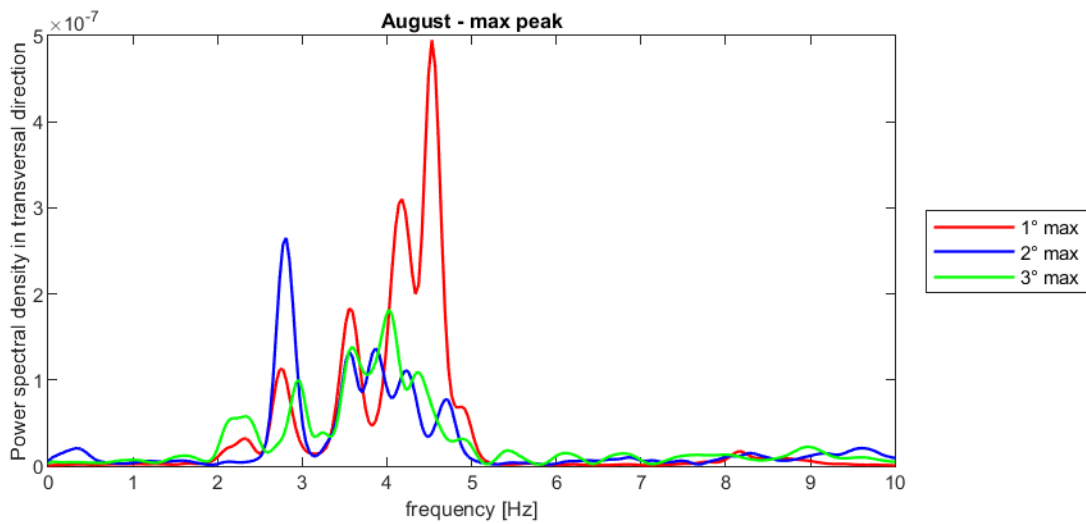

Figure 0-96: Results obtained from the 3 accelerograms with highest peak if PSD

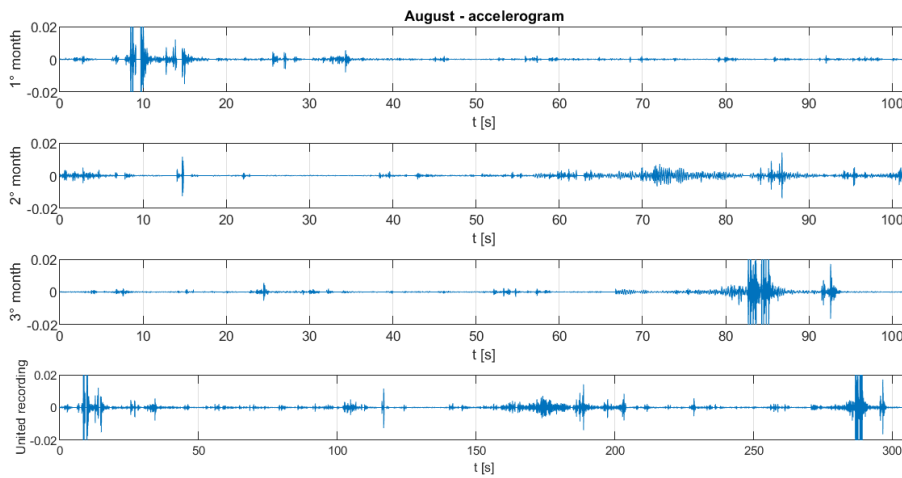

Figure 0-97: Accelerograms in transverse (z) direction with maximum standard deviation in time domain

10.9 September

The results obtained for the September dataset are shown in the following tables.

Table 0-25: September 2023 - Accelerograms with the maximum standard deviation

	#	Accelerogram	Standard deviation
Vertical direction (x)	1°	319E3_2023-09-26_15-00-20	1.95E-04
	2°	319E3_2023-09-15_11-00-20	1.72E-04
	3°	319E3_2023-09-28_16-00-20	1.59E-04
Longitudinal direction (y)	1°	319E3_2023-09-26_15-00-20	1.24E-03
	2°	319E3_2023-09-15_11-00-20	1.23E-03
	3°	319E3_2023-09-20_11-00-20	1.02E-03
Transverse direction (z)	1°	319E3_2023-09-14_11-00-20	9.59E-04
	2°	319E3_2023-09-28_16-00-20	9.30E-04
	3°	319E3_2023-09-15_11-00-20	8.87E-04

Table 0-26: September 2023 - Accelerograms defined by the maximum area and peak of the power spectral density function

Vertical direction (x)				
#	Accelerogram	Peak value	Accelerogram	Area
1	319E3_2023-09-26_15-00-20	6.26E-08	319E3_2023-09-26_15-00-20	8.07E-09
2	319E3_2023-09-15_11-00-20	2.58E-08	319E3_2023-09-15_11-00-20	6.19E-09
3	319E3_2023-09-26_09-00-19	2.20E-08	319E3_2023-09-28_16-00-20	5.21E-09
Longitudinal direction (y)				
	Accelerogram	Peak value	Accelerogram	Area
1	319E3_2023-09-15_11-00-20	3.01E-06	319E3_2023-09-26_15-00-20	3.17E-07
2	319E3_2023-09-27_03-00-20	2.22E-06	319E3_2023-09-15_11-00-20	3.04E-07
3	319E3_2023-09-26_15-00-20	2.21E-06	319E3_2023-09-20_11-00-20	2.14E-07
Transverse direction (z)				
	Accelerogram	Peak value	Accelerogram	Area
1	319E3_2023-09-15_11-00-20	1.01E-06	319E3_2023-09-14_11-00-20	1.84E-07
2	319E3_2023-09-26_15-00-20	9.21E-07	319E3_2023-09-28_16-00-20	1.77E-07
3	319E3_2023-09-26_09-00-19	6.98E-07	319E3_2023-09-15_11-00-20	1.62E-07

Table 0-27: September 2023 – Statistical analysis

	Vertical X			Longitudinal Y			Transverse Z		
	Std	Peak	Area	Std	Peak	Area	Std	Peak	Area
1	A	A	A	A	B	A	E	B	E
2	B	B	B	B	-	B	C	-	C
3	C	-	C	D	A	D	B	-	B

10.9.1 Vertical direction (x)

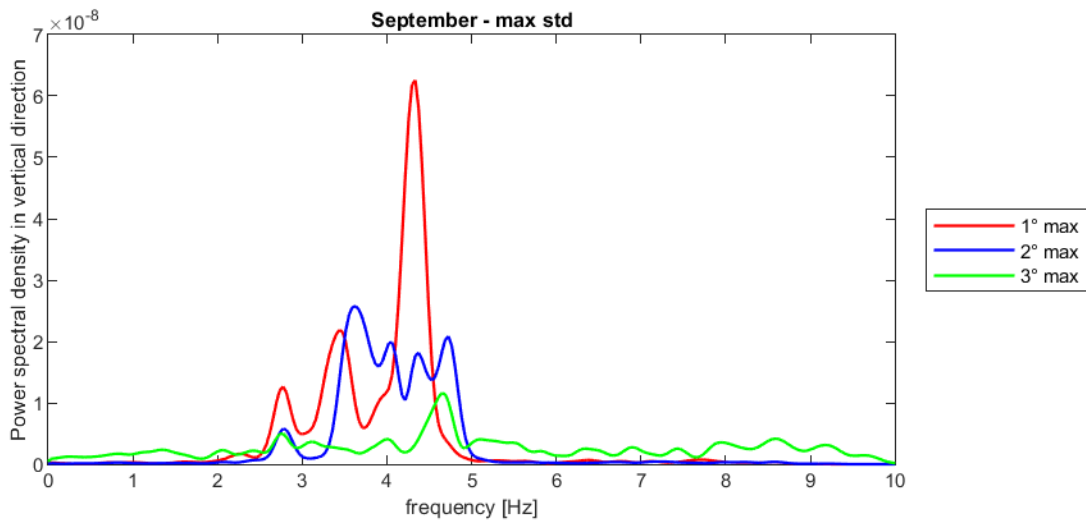

Figure 0-98: Results obtained from the 3 accelerograms with maximum SD in time domain

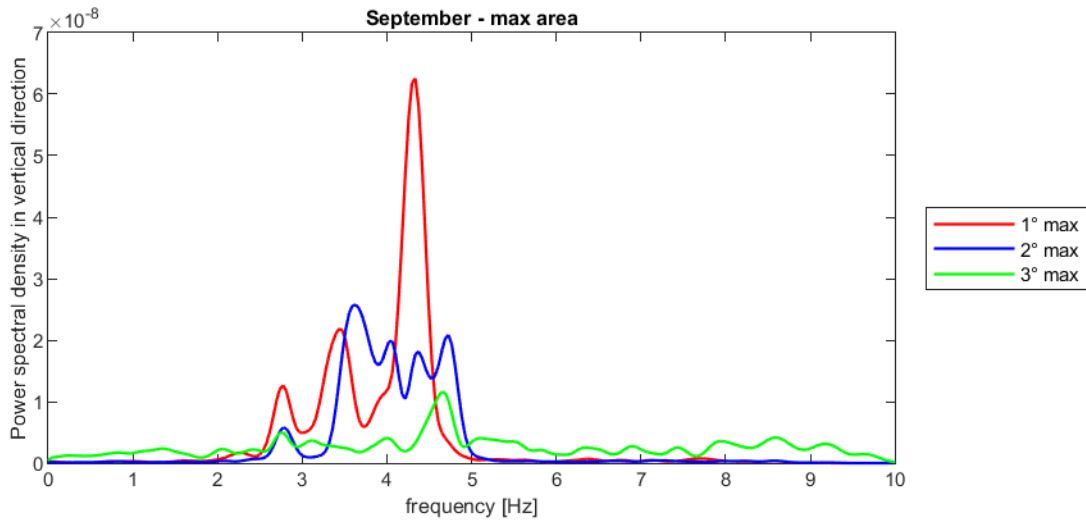

Figure 0-99: Results obtained from the 3 accelerograms with maximum area of PSD

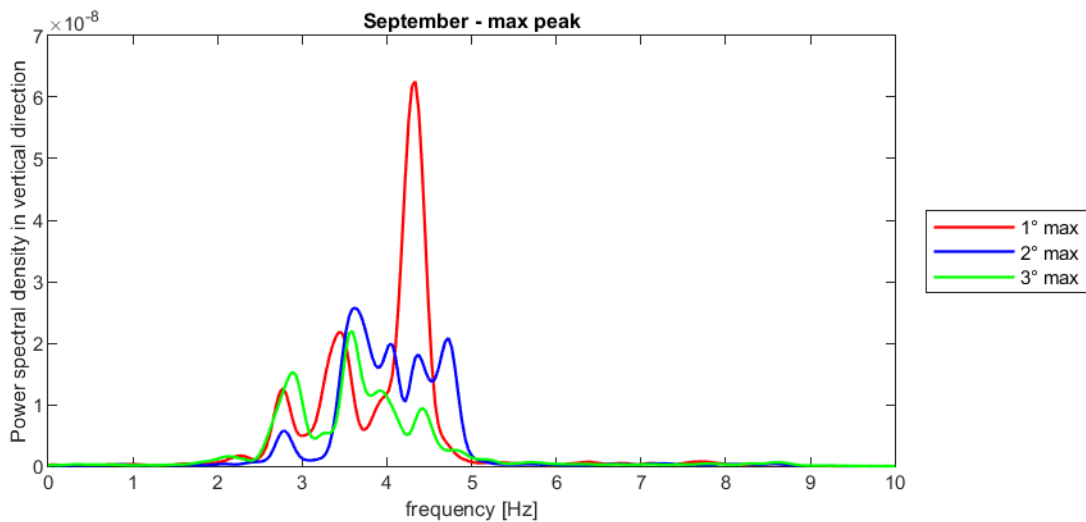

Figure 0-100: Results obtained from the 3 accelerograms with highest peak if PSD

Monitoring activity on Fiorenza Node of A4 Highway

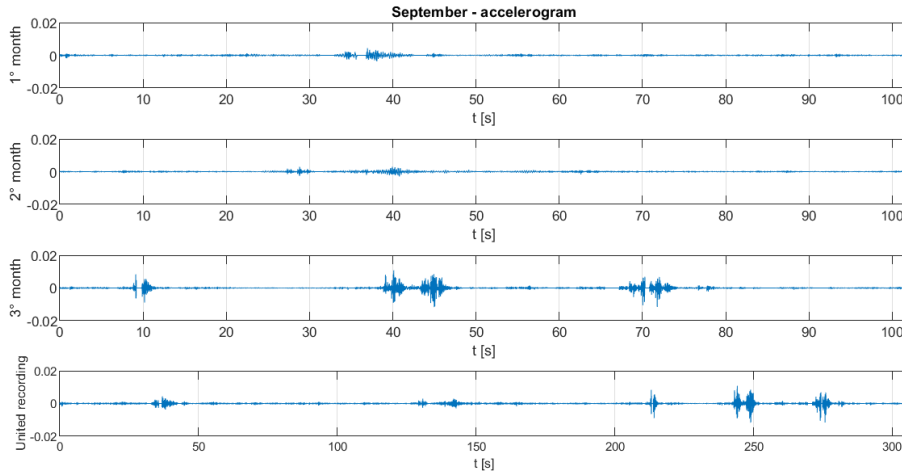

Figure 0-101: Accelerograms in vertical (x) direction with maximum standard deviation in time domain

10.9.2 Longitudinal direction (y)

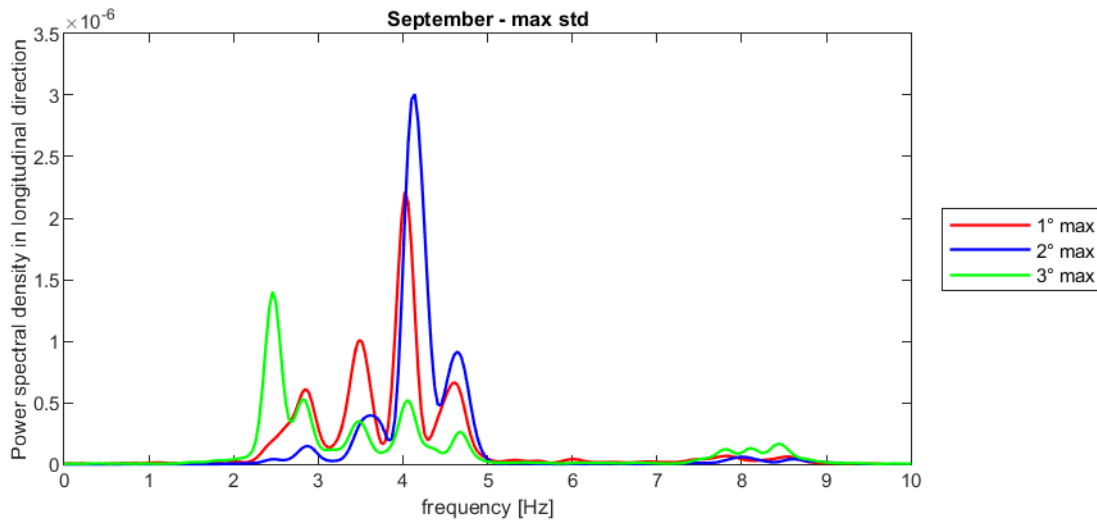

Figure 0-102: Results obtained from the 3 accelerograms with maximum SD in time domain

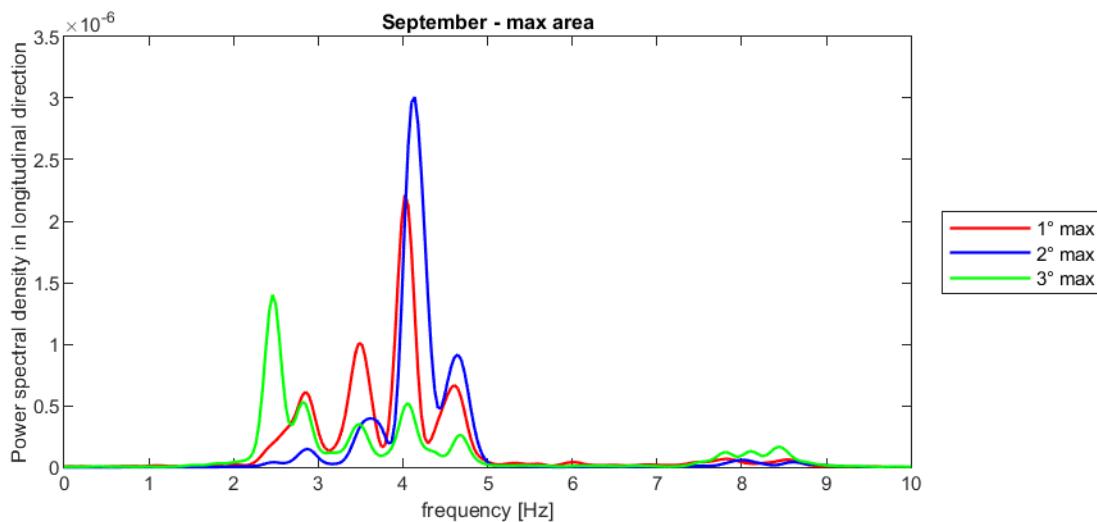

Figure 0-103: Results obtained from the 3 accelerograms with maximum area of PSD

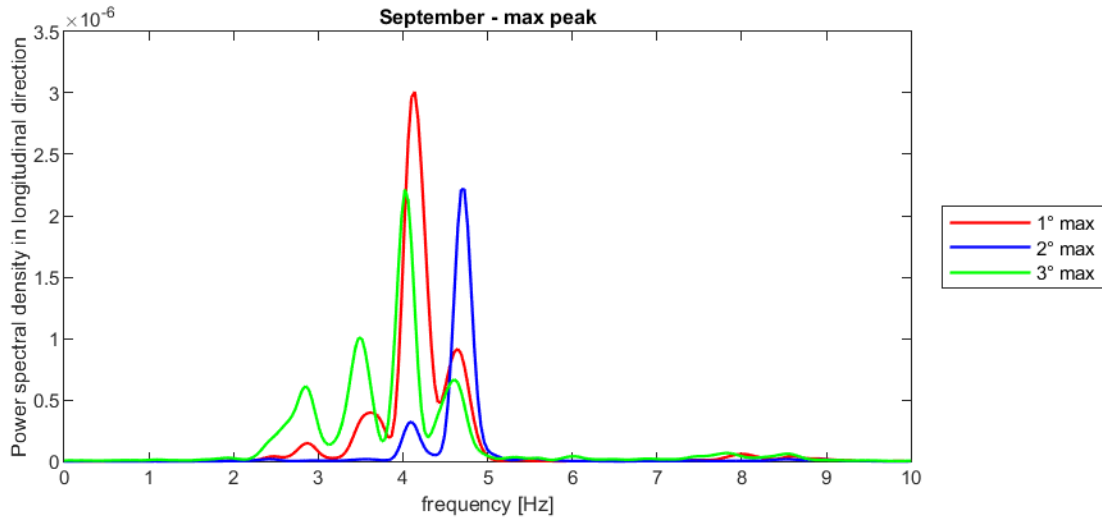

Figure 0-104: Results obtained from the 3 accelerograms with highest peak if PSD

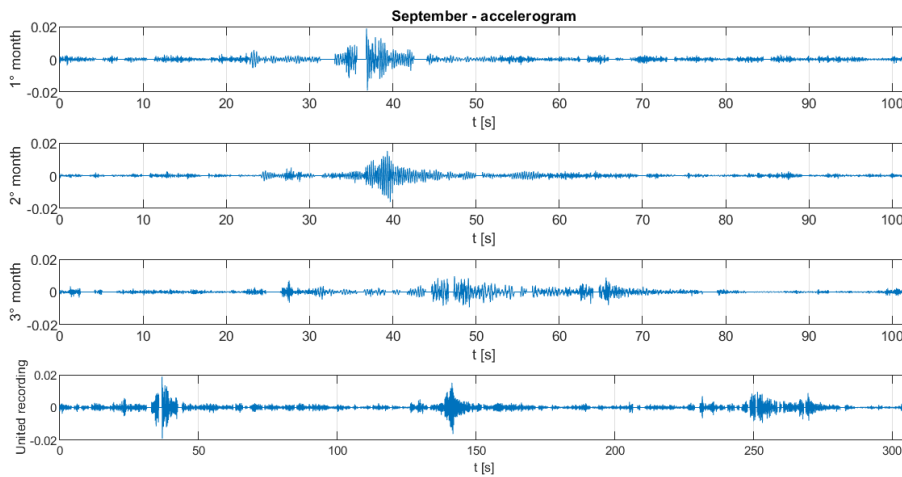

Figure 0-105: Accelerograms in longitudinal (y) direction with maximum standard deviation in time domain

10.9.3 Transverse direction (z)

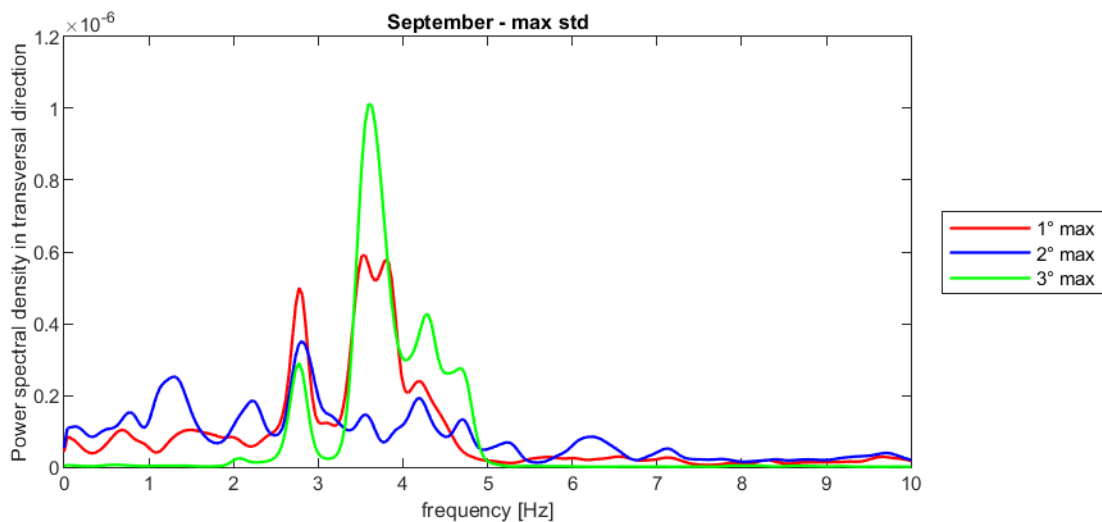

Figure 0-106: Results obtained from the 3 accelerograms with maximum SD in time domain

Monitoring activity on Fiorenza Node of A4 Highway

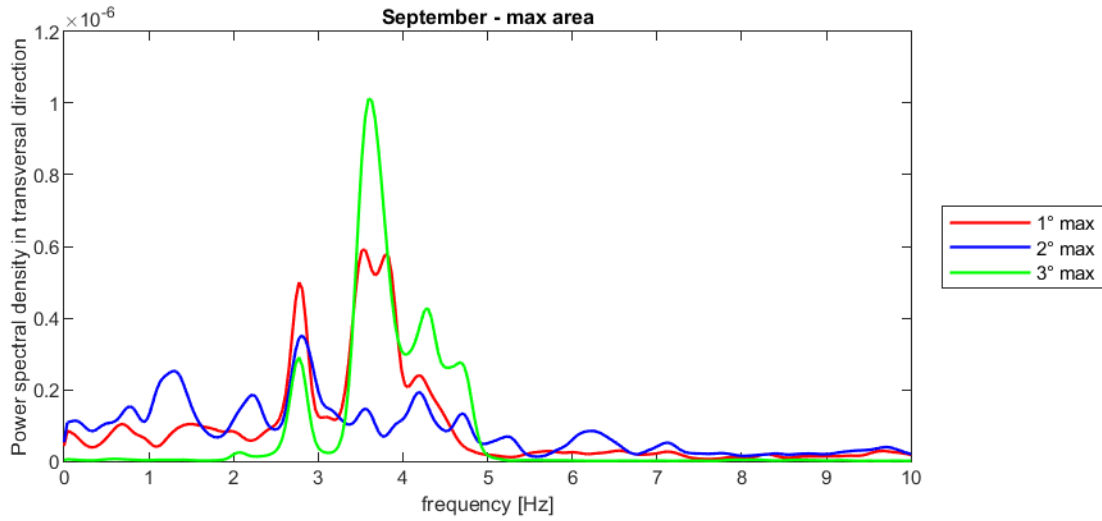

Figure 0-107: Results obtained from the 3 accelerograms with maximum area of PSD

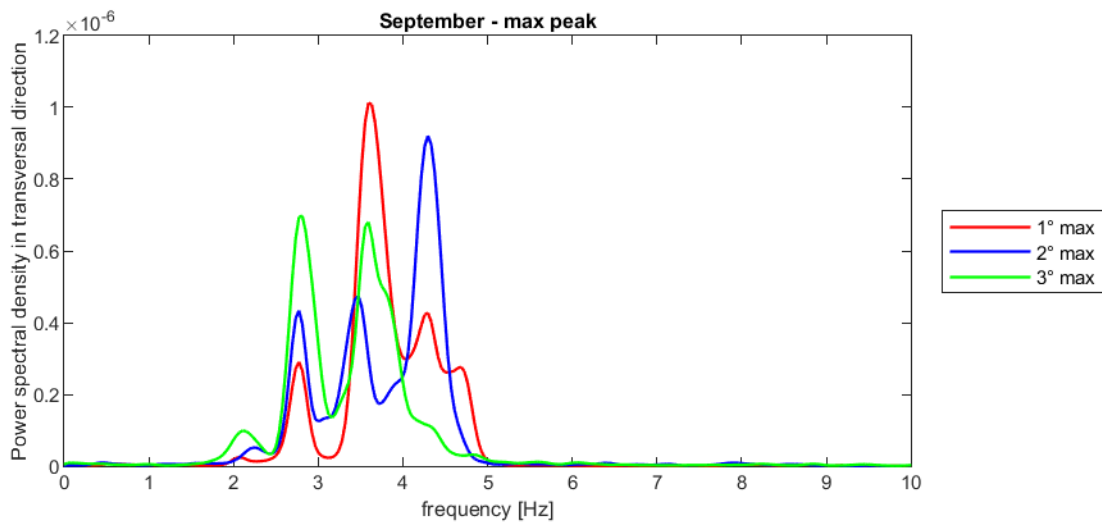

Figure 0-108: Results obtained from the 3 accelerograms with highest peak if PSD

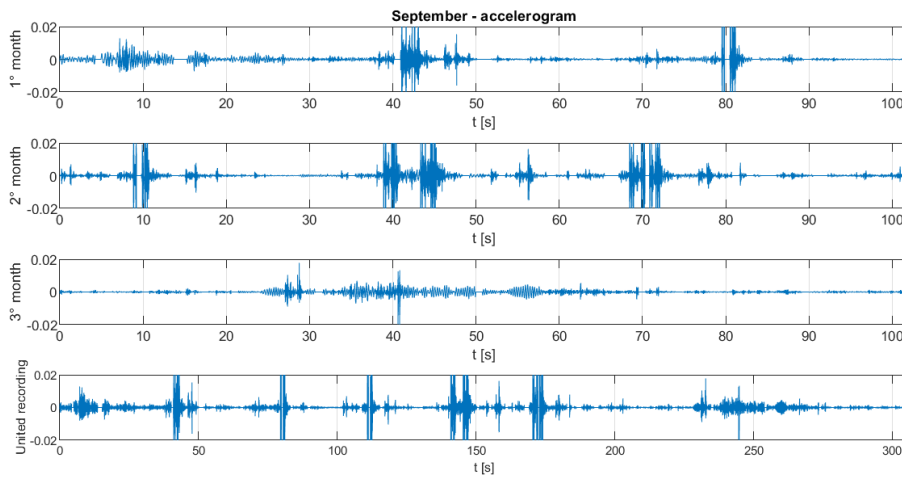

Figure 0-109: Accelerograms in transverse (z) direction with maximum standard deviation in time domain

10.10 October

The results obtained for the October dataset are shown in the following tables.

Table 0-28: October 2023 - Accelerograms with the maximum standard deviation

	#	Accelerogram	Standard deviation
Vertical direction (x)	1°	319E3_2023-10-25_10-00-20	1.32E-04
	2°	319E3_2023-10-12_09-00-20	1.30E-04
	3°	319E3_2023-10-02_08-00-21	1.28E-04
Longitudinal direction (y)	1°	319E3_2023-10-25_10-00-20	1.09E-03
	2°	319E3_2023-10-05_18-00-21	9.85E-04
	3°	319E3_2023-10-12_09-00-20	9.85E-04
Transverse direction (z)	1°	319E3_2023-10-12_09-00-20	7.97E-04
	2°	319E3_2023-10-25_10-00-20	7.96E-04
	3°	319E3_2023-10-16_08-00-20	7.27E-04

Table 0-29: October 2023 - Accelerograms defined by the maximum area and peak of the power spectral density function

Vertical direction (x)				
#	Accelerogram	Peak value	Accelerogram	Area
1	319E3_2023-10-02_08-00-21	1.65E-08	319E3_2023-10-12_09-00-20	3.59E-09
2	319E3_2023-10-12_09-00-20	1.53E-08	319E3_2023-10-25_10-00-20	3.56E-09
3	319E3_2023-10-26_12-00-20	1.37E-08	319E3_2023-10-02_08-00-21	3.37E-09
Longitudinal direction (y)				
	Accelerogram	Peak value	Accelerogram	Area
1	319E3_2023-10-05_18-00-21	1.91E-06	319E3_2023-10-25_10-00-20	2.37E-07
2	319E3_2023-10-12_16-00-20	1.54E-06	319E3_2023-10-12_09-00-20	2.04E-07
3	319E3_2023-10-09_13-00-20	1.28E-06	319E3_2023-10-05_18-00-21	2.00E-07
Transverse direction (z)				
	Accelerogram	Peak value	Accelerogram	Area
1	319E3_2023-10-02_08-00-21	5.23E-07	319E3_2023-10-12_09-00-20	1.35E-07
2	319E3_2023-10-12_09-00-20	4.98E-07	319E3_2023-10-25_10-00-20	1.32E-07
3	319E3_2023-10-25_10-00-20	4.98E-07	319E3_2023-10-26_12-00-20	9.82E-08

Table 0-30: October 2023 – Statistical analysis

	Vertical X			Longitudinal Y			Transverse Z		
	Std	Peak	Area	Std	Peak	Area	Std	Peak	Area
1	A	C	B	A	D	A	B	-	B
2	B	B	A	D	-	B	A	B	A
3	C	-	C	B	-	D	-	A	-

10.10.1 Vertical direction (x)

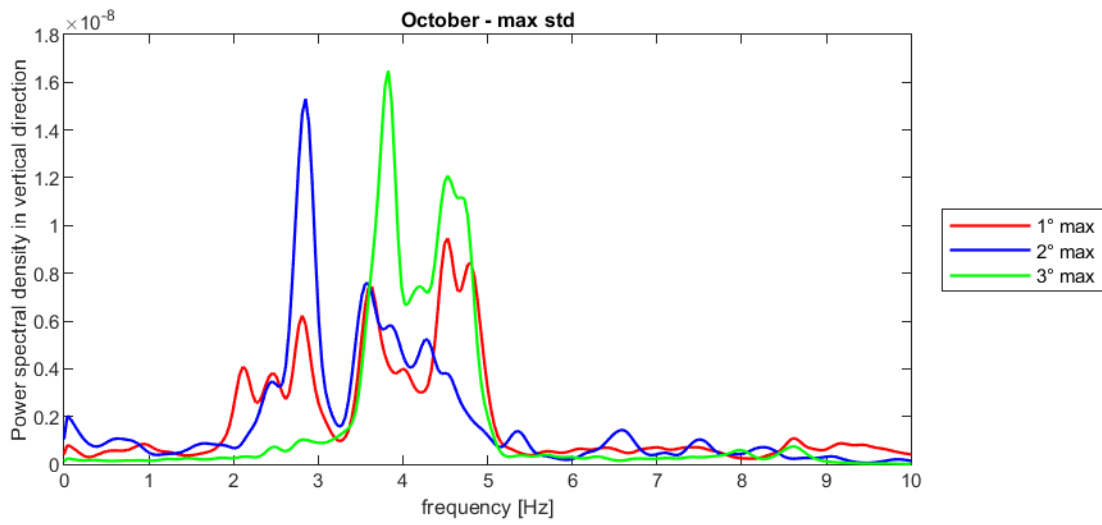

Figure 0-110: Results obtained from the 3 accelerograms with maximum SD in time domain

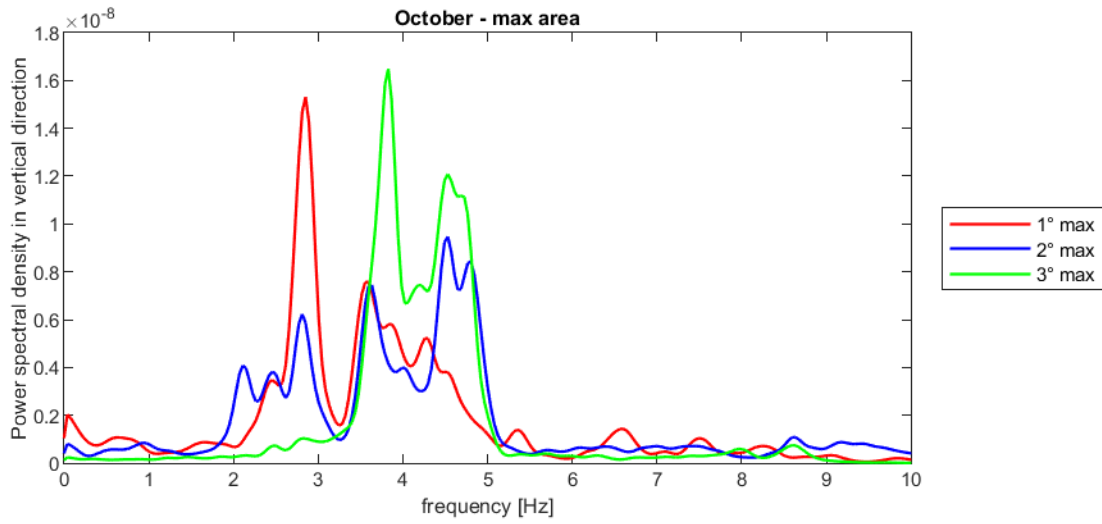

Figure 0-111: Results obtained from the 3 accelerograms with maximum area of PSD

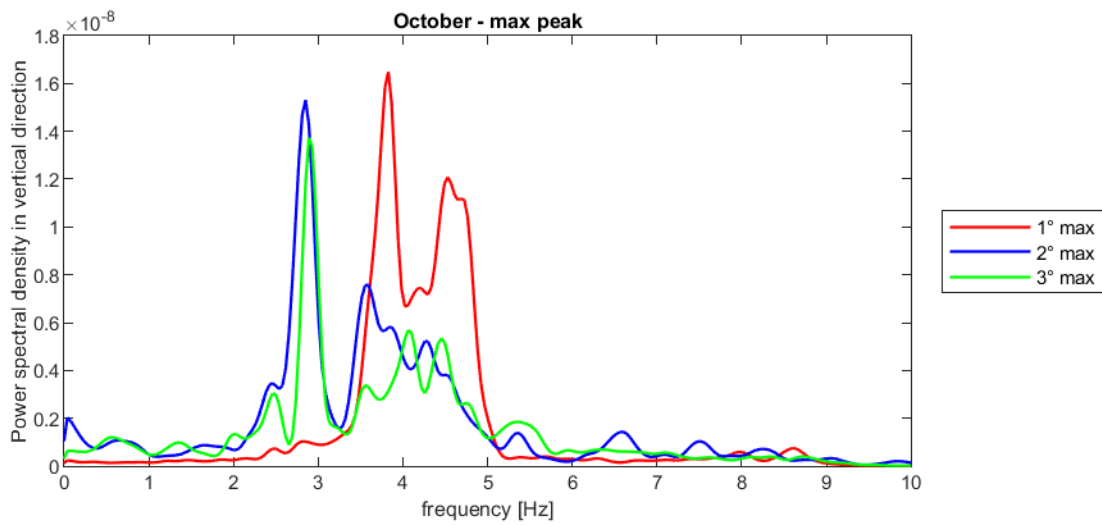

Figure 0-112: Results obtained from the 3 accelerograms with highest peak if PSD

Monitoring activity on Fiorenza Node of A4 Highway

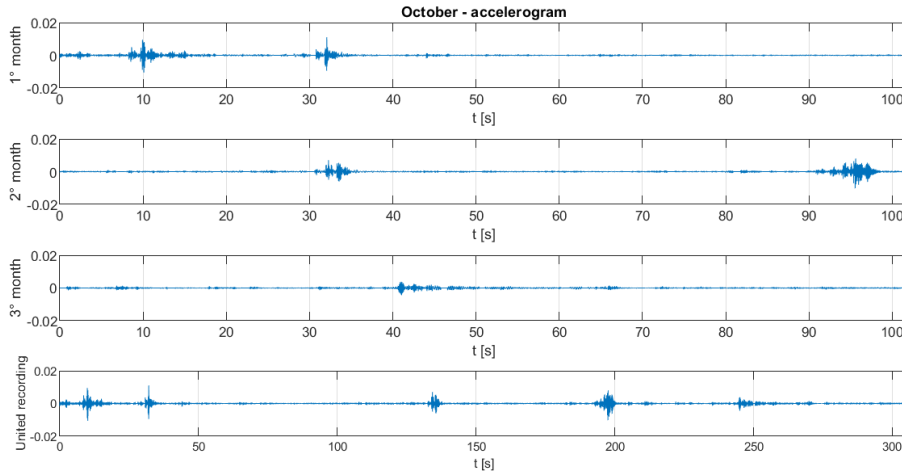

Figure 0-113: Accelerograms in vertical (x) direction with maximum standard deviation in time domain

10.10.2 Longitudinal direction (y)

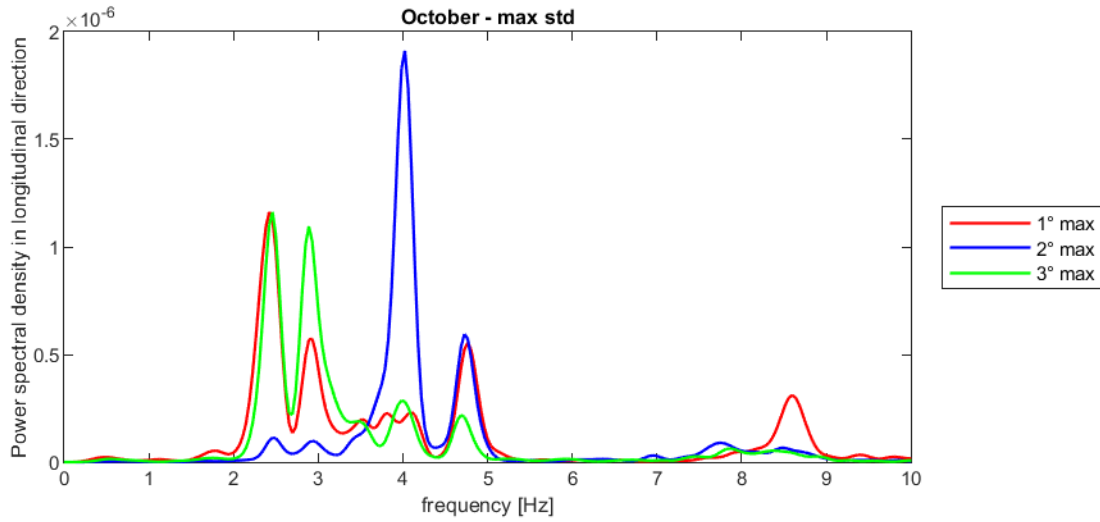

Figure 0-114: Results obtained from the 3 accelerograms with maximum SD in time domain

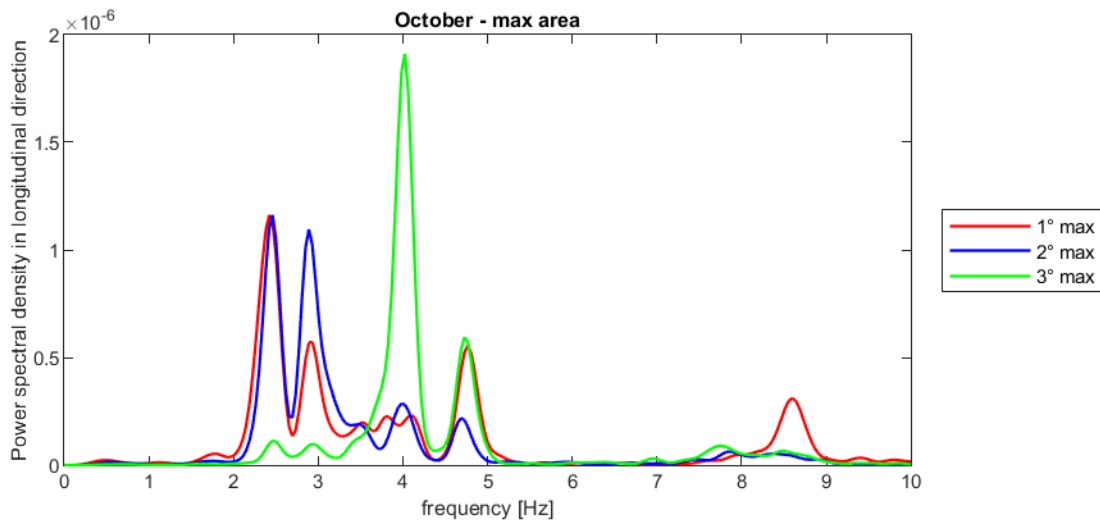

Figure 0-115: Results obtained from the 3 accelerograms with maximum area of PSD

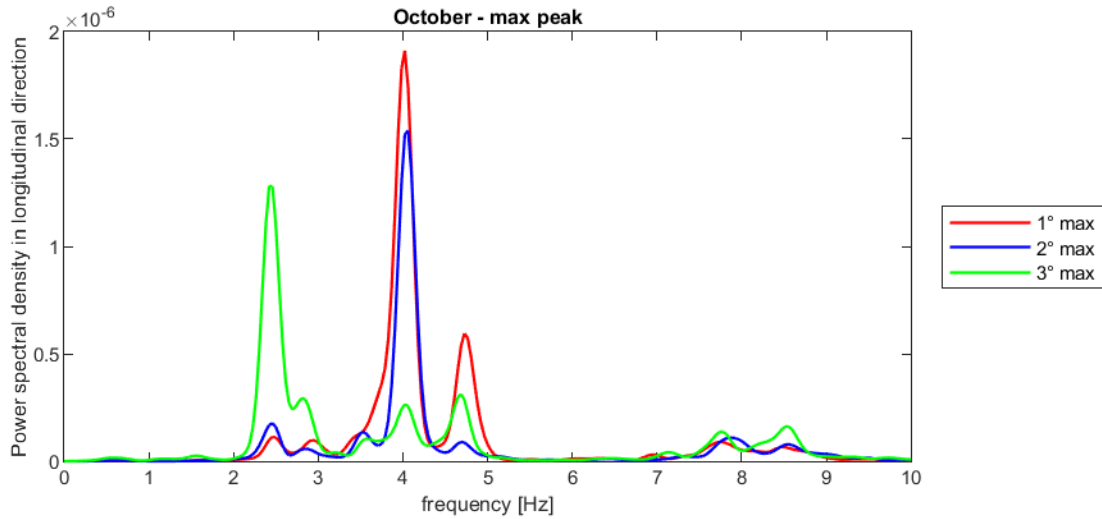

Figure 0-116: Results obtained from the 3 accelerograms with highest peak if PSD

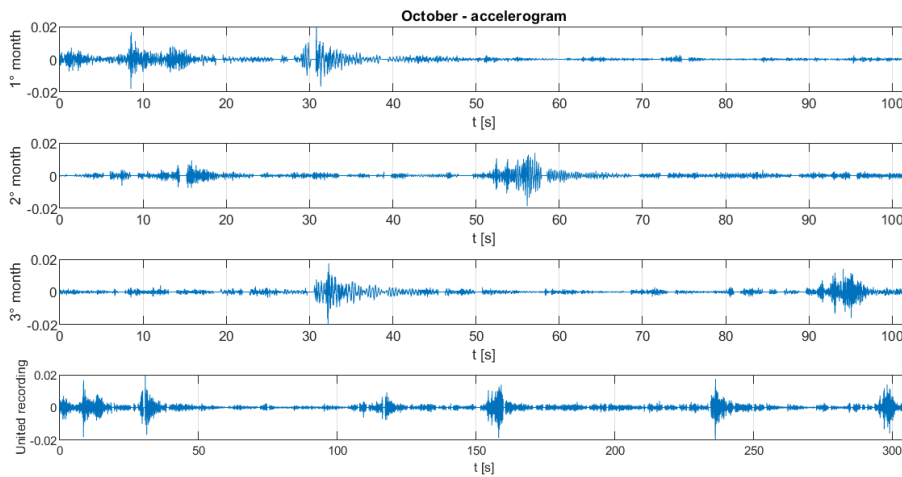

Figure 0-117: Accelerograms in longitudinal (y) direction with maximum standard deviation in time domain

10.10.3 Transverse direction (z)

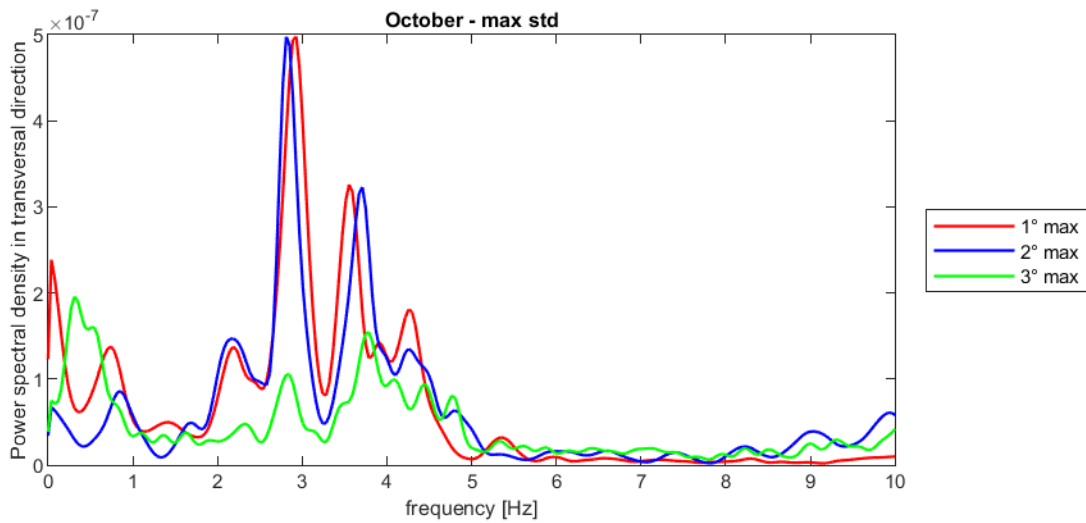

Figure 0-118: Results obtained from the 3 accelerograms with maximum SD in time domain

Monitoring activity on Fiorenza Node of A4 Highway

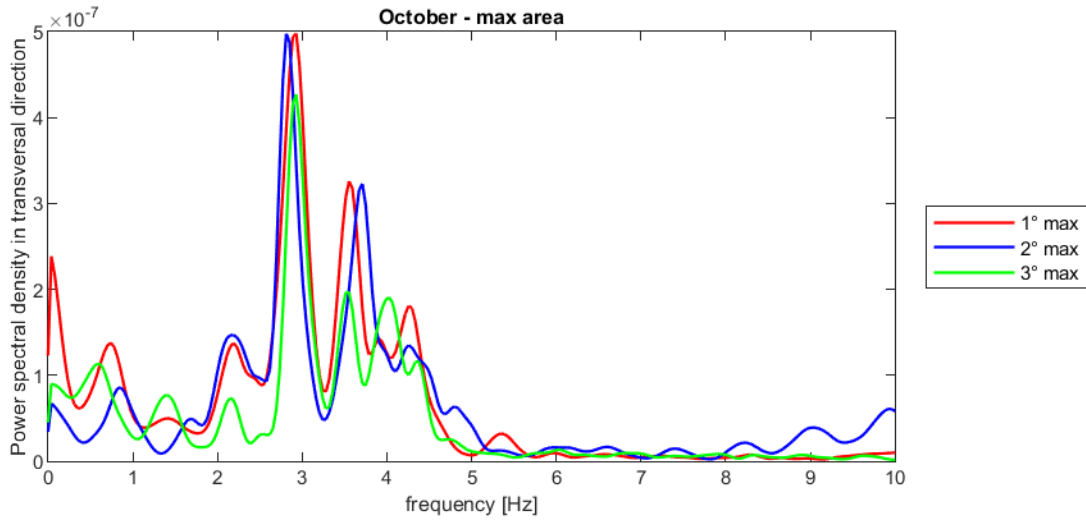

Figure 0-119: Results obtained from the 3 accelerograms with maximum area of PSD

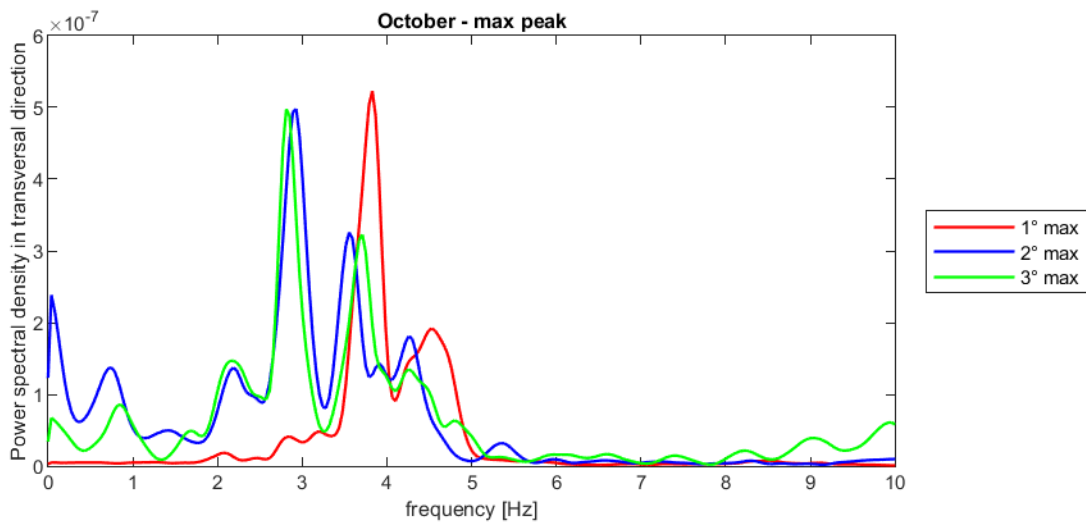

Figure 0-120: Results obtained from the 3 accelerograms with highest peak if PSD

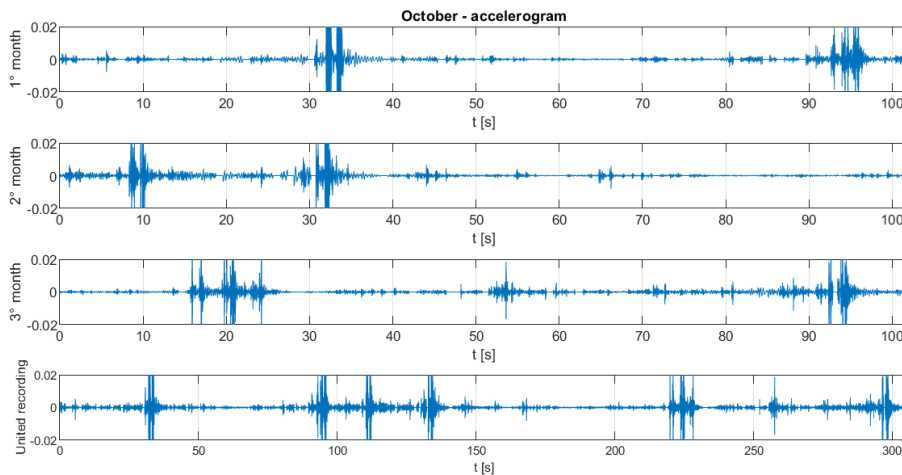

Figure 0-121: Accelerograms in transverse (z) direction with maximum standard deviation in time domain

10.11 November

The results obtained for the November dataset are shown in the following tables.

Table 0-31: November 2023 - Accelerograms with the maximum standard deviation

	#	Accelerogram	Standard deviation
Vertical direction (x)	1°	319E3_2023-11-07_17-00-21	1.58E-04
	2°	319E3_2023-11-06_17-00-20	1.47E-04
	3°	319E3_2023-11-23_09-00-20	1.46E-04
Longitudinal direction (y)	1°	319E3_2023-11-06_17-00-20	1.22E-03
	2°	319E3_2023-11-10_08-00-19	1.16E-03
	3°	319E3_2023-11-28_11-00-21	1.07E-03
Transverse direction (z)	1°	319E3_2023-11-06_17-00-20	8.53E-04
	2°	319E3_2023-11-07_17-00-21	7.87E-04
	3°	319E3_2023-11-15_13-00-20	7.82E-04

Table 0-32: November 2023 - Accelerograms defined by the maximum area and peak of the power spectral density function

Vertical direction (x)				
#	Accelerogram	Peak value	Accelerogram	Area
1	319E3_2023-11-23_09-00-20	2.29E-08	319E3_2023-11-07_17-00-21	5.32E-09
2	319E3_2023-11-07_17-00-21	2.23E-08	319E3_2023-11-06_17-00-20	4.43E-09
3	319E3_2023-11-29_02-00-20	2.14E-08	319E3_2023-11-23_09-00-20	4.32E-09
Longitudinal direction (y)				
	Accelerogram	Peak value	Accelerogram	Area
1	319E3_2023-11-14_10-00-21	2.85E-06	319E3_2023-11-06_17-00-20	3.01E-07
2	319E3_2023-11-06_17-00-20	1.84E-06	319E3_2023-11-10_08-00-19	2.82E-07
3	319E3_2023-11-28_11-00-21	1.78E-06	319E3_2023-11-28_11-00-21	2.45E-07
Transverse direction (z)				
	Accelerogram	Peak value	Accelerogram	Area
1	319E3_2023-11-06_17-00-20	8.38E-07	319E3_2023-11-06_17-00-20	1.48E-07
2	319E3_2023-11-28_11-00-21	7.22E-07	319E3_2023-11-15_13-00-20	1.34E-07
3	319E3_2023-11-15_13-00-20	6.74E-07	319E3_2023-11-07_17-00-21	1.34E-07

Table 0-33: November 2023 – Statistical analysis

	Vertical X			Longitudinal Y			Transverse Z		
	Std	Peak	Area	Std	Peak	Area	Std	Peak	Area
1	A	C	A	B	-	B	B	B	B
2	B	A	B	D	B	D	A	-	F
3	C	-	C	E	E	E	F	F	A

10.11.1 Vertical direction (x)

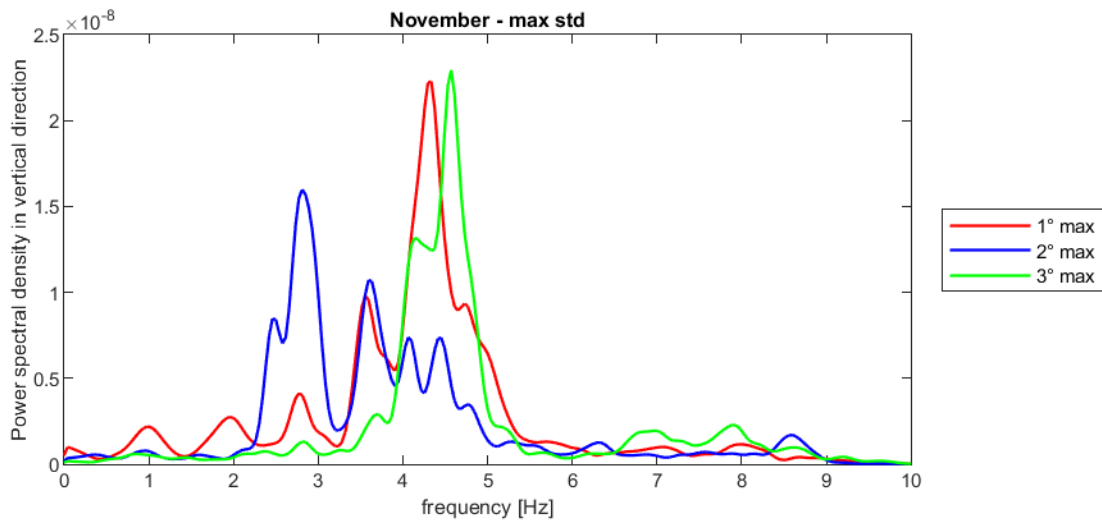

Figure 0-122: Results obtained from the 3 accelerograms with maximum SD in time domain

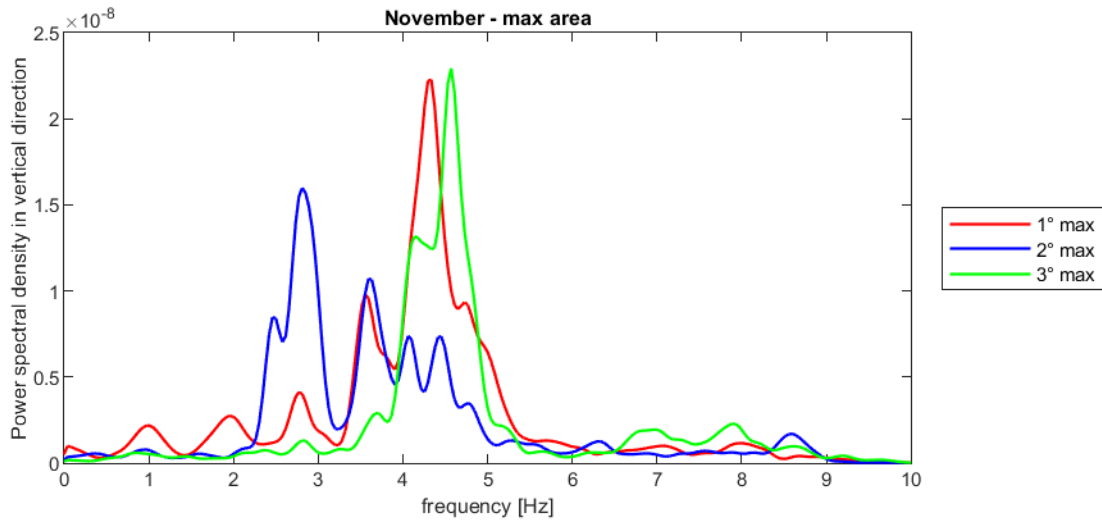

Figure 0-123: Results obtained from the 3 accelerograms with maximum area of PSD

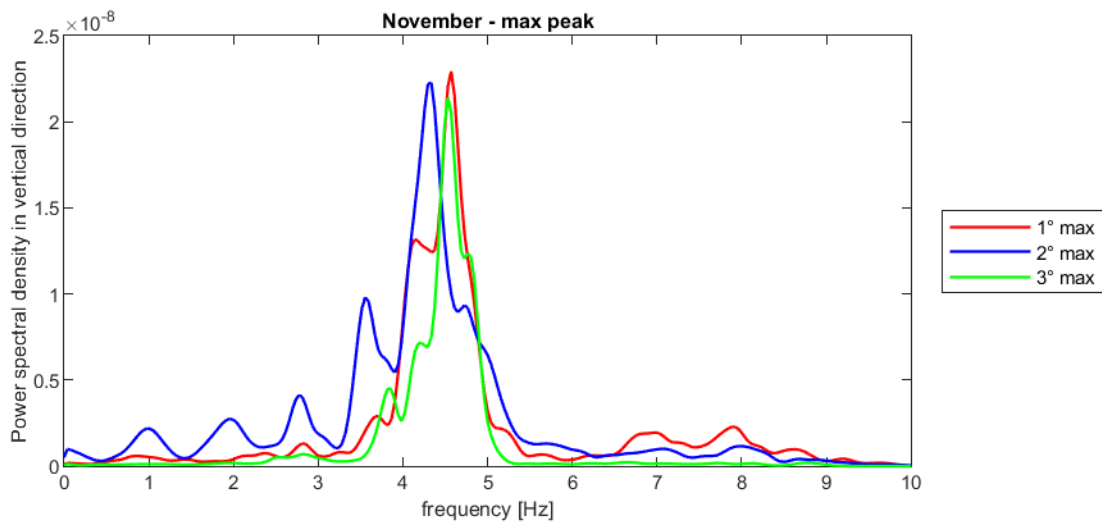

Figure 0-124: Results obtained from the 3 accelerograms with highest peak if PSD

Monitoring activity on Fiorenza Node of A4 Highway

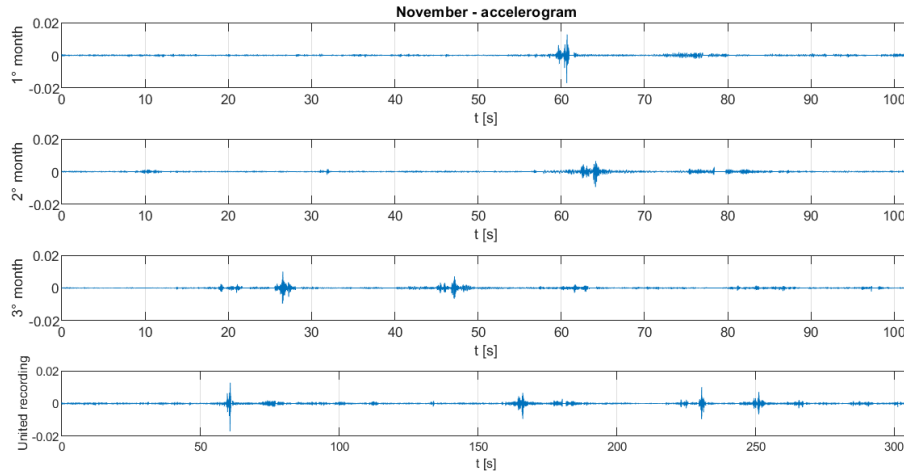

Figure 0-125: Accelerograms in vertical (x) direction with maximum standard deviation in time domain

10.11.2 Longitudinal direction (y)

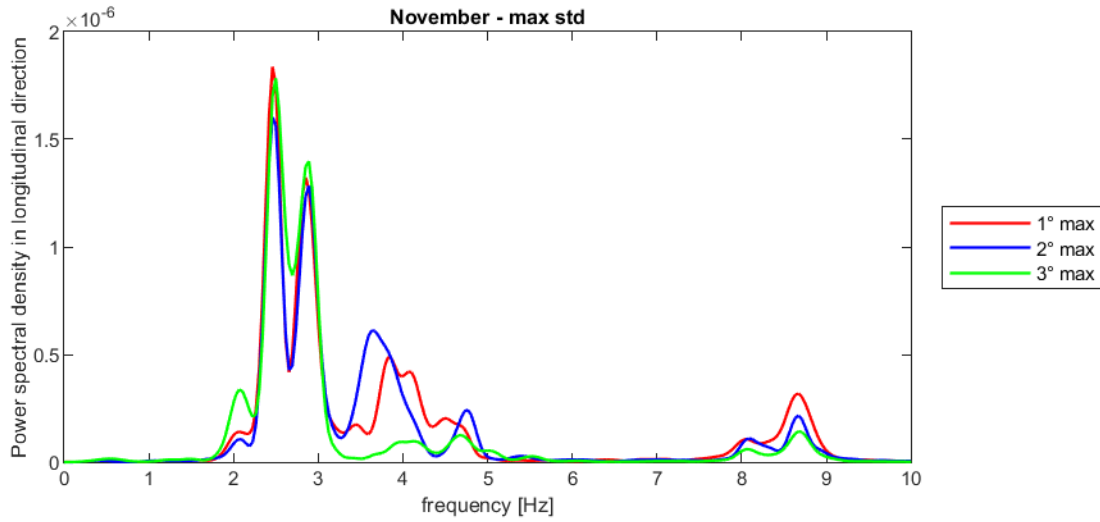

Figure 0-126: Results obtained from the 3 accelerograms with maximum SD in time domain

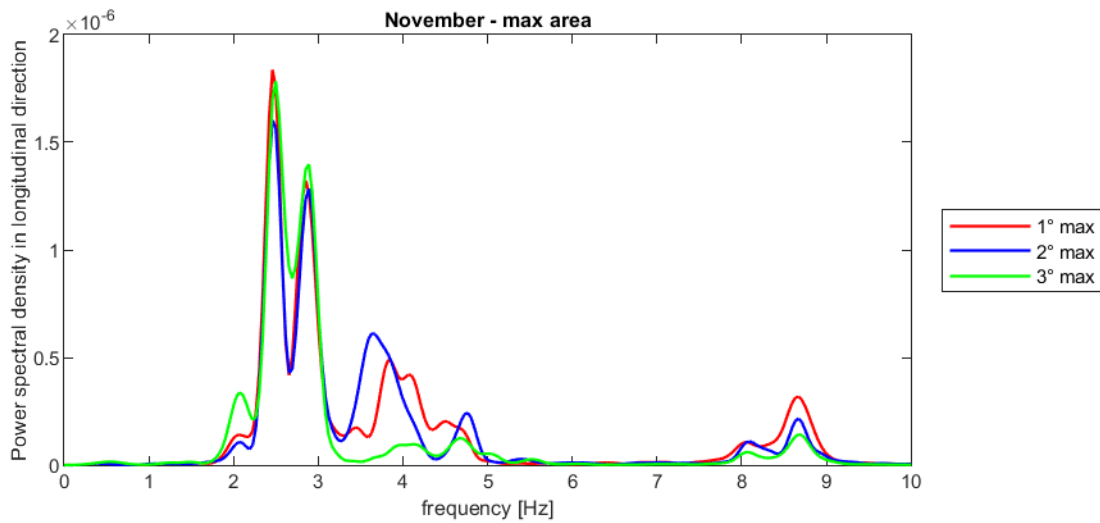

Figure 0-127: Results obtained from the 3 accelerograms with maximum area of PSD

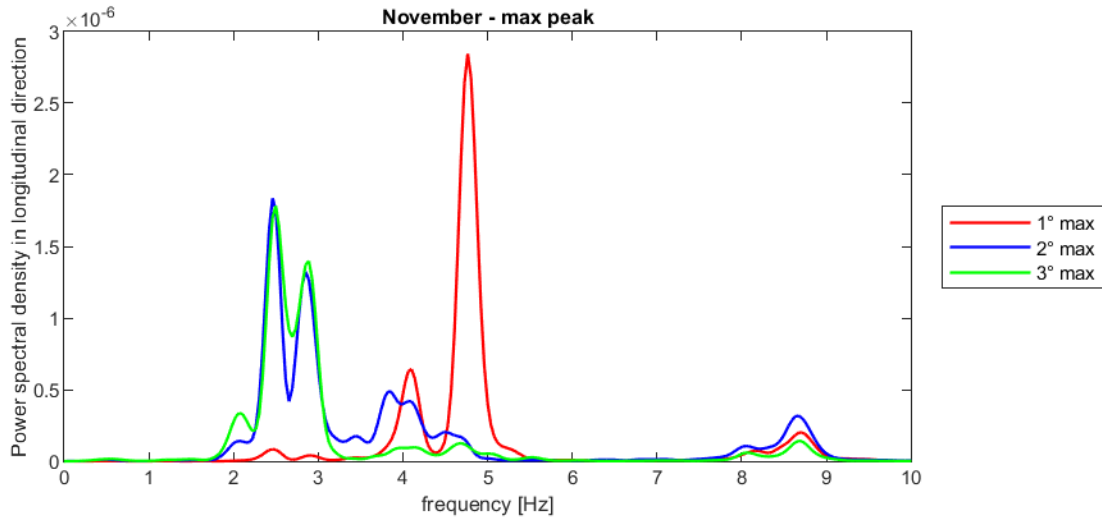

Figure 0-128: Results obtained from the 3 accelerograms with highest peak if PSD

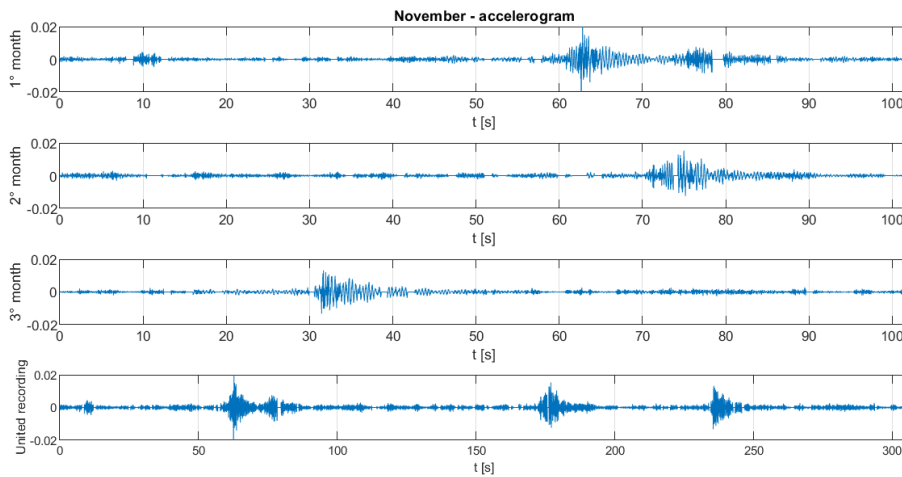

Figure 0-129: Accelerograms in longitudinal (y) direction with maximum standard deviation in time domain

10.11.3 Transverse direction (z)

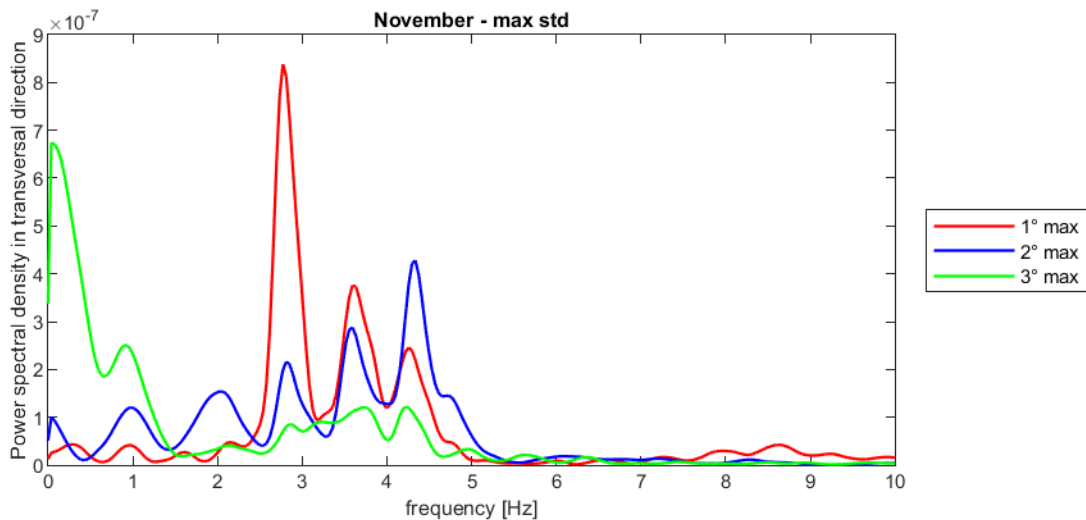

Figure 0-130: Results obtained from the 3 accelerograms with maximum SD in time domain

Monitoring activity on Fiorenza Node of A4 Highway

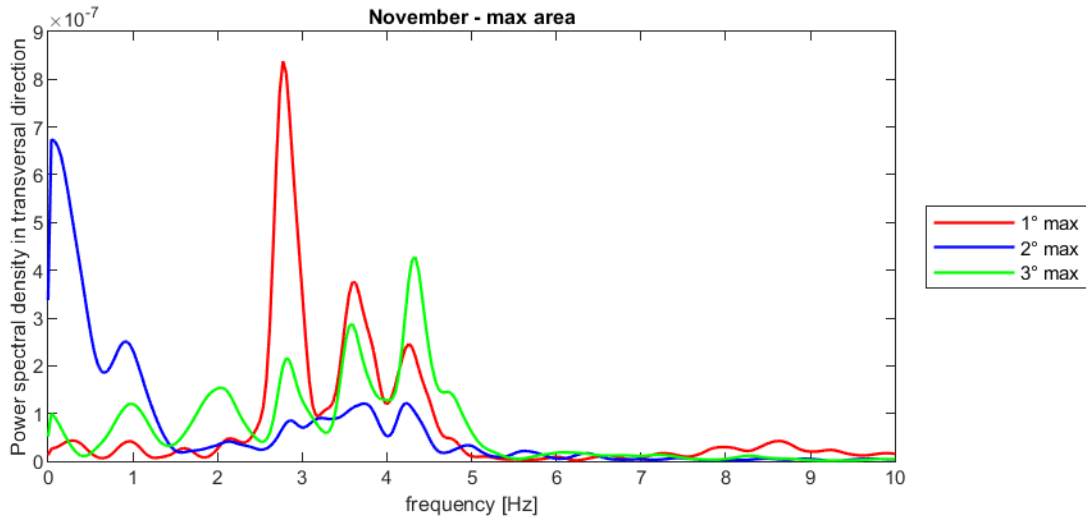

Figure 0-131: Results obtained from the 3 accelerograms with maximum area of PSD

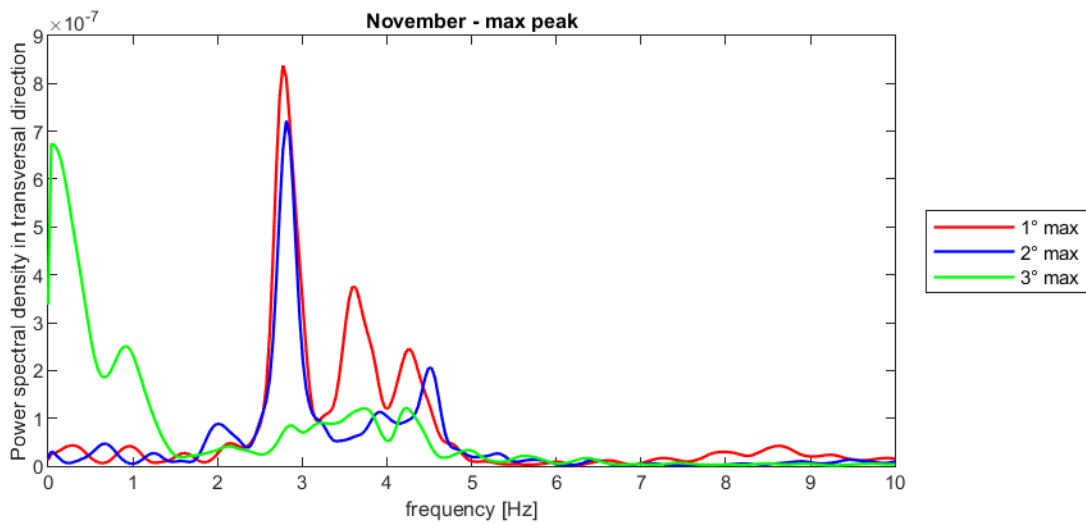

Figure 0-132: Results obtained from the 3 accelerograms with highest peak if PSD

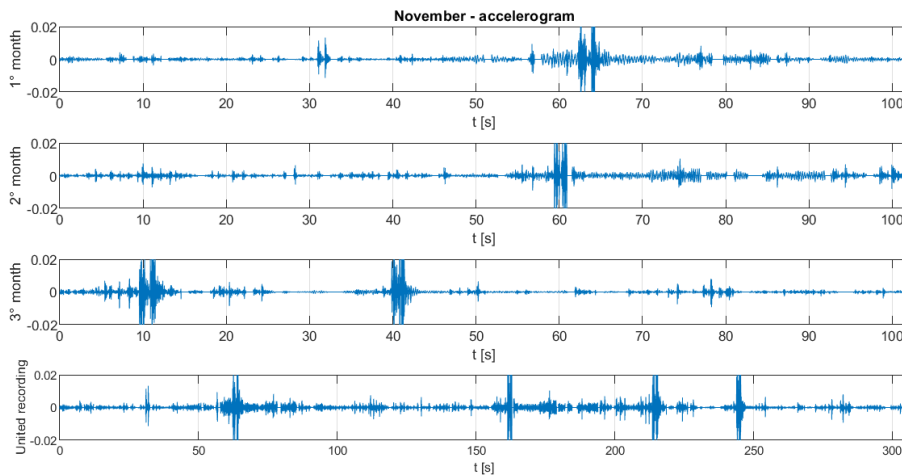

Figure 0-133: Accelerograms in transverse (z) direction with maximum standard deviation in time domain

10.12 December

The results obtained for the December dataset are shown in the following tables.

Table 0-34: December 2023 - Accelerograms with the maximum standard deviation

	#	Accelerogram	Standard deviation
Vertical direction (x)	1°	319E3_2023-12-06_10-00-20	1.79E-04
	2°	319E3_2023-12-13_08-00-20	1.46E-04
	3°	319E3_2023-12-28_09-00-20	1.43E-04
Longitudinal direction (y)	1°	319E3_2023-12-18_08-00-19	1.23E-03
	2°	319E3_2023-12-11_14-00-19	1.15E-03
	3°	319E3_2023-12-28_09-00-20	1.06E-03
Transverse direction (z)	1°	319E3_2023-12-06_10-00-20	7.79E-04
	2°	319E3_2023-12-18_08-00-19	7.76E-04
	3°	319E3_2023-12-13_08-00-20	7.71E-04

Table 0-35: December 2023 - Accelerograms defined by the maximum area and peak of the power spectral density function

Vertical direction (x)				
#	Accelerogram	Peak value	Accelerogram	Area
1	319E3_2023-12-06_10-00-20	2.86E-08	319E3_2023-12-06_10-00-20	6.77E-09
2	319E3_2023-12-13_08-00-20	1.66E-08	319E3_2023-12-18_08-00-19	4.49E-09
3	319E3_2023-12-28_09-00-20	1.60E-08	319E3_2023-12-13_08-00-20	4.46E-09
Longitudinal direction (y)				
	Accelerogram	Peak value	Accelerogram	Area
1	319E3_2023-12-11_14-00-19	1.75E-06	319E3_2023-12-18_08-00-19	3.17E-07
2	319E3_2023-12-18_08-00-19	1.59E-06	319E3_2023-12-11_14-00-19	2.75E-07
3	319E3_2023-12-28_09-00-20	1.48E-06	319E3_2023-12-28_09-00-20	2.40E-07
Transverse direction (z)				
	Accelerogram	Peak value	Accelerogram	Area
1	319E3_2023-12-11_14-00-19	5.34E-07	319E3_2023-12-13_08-00-20	1.29E-07
2	319E3_2023-12-13_08-00-20	4.68E-07	319E3_2023-12-18_08-00-19	1.27E-07
3	319E3_2023-12-18_08-00-19	4.65E-07	319E3_2023-12-11_14-00-19	1.20E-07

Table 0-36: December 2023 – Statistical analysis

	Vertical X			Longitudinal Y			Transverse Z		
	Std	Peak	Area	Std	Peak	Area	Std	Peak	Area
1	A	A	A	D	E	D	-	E	B
2	B	B	-	E	D	E	D	B	D
3	C	C	B	C	C	C	B	D	E

10.12.1 Vertical direction (x)

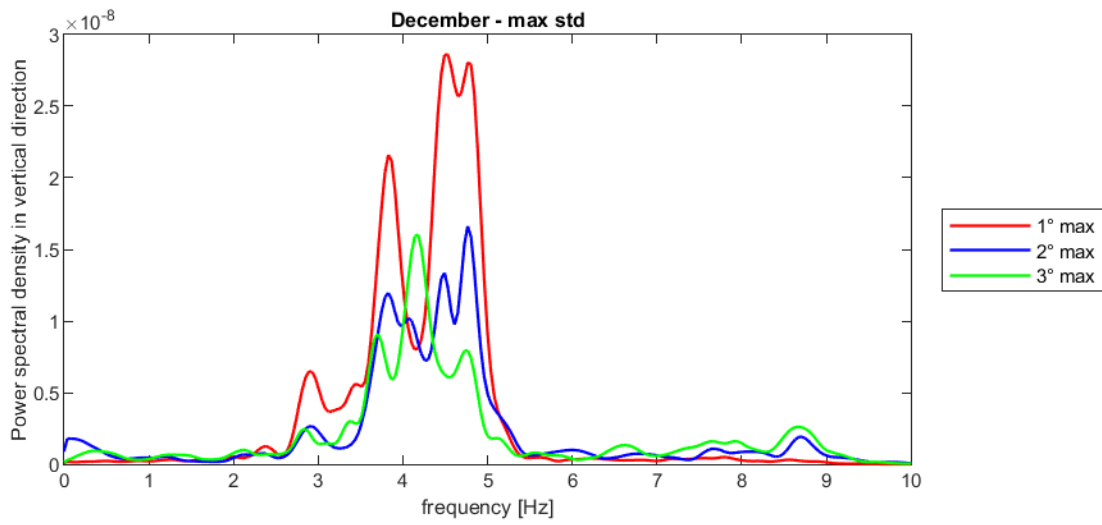

Figure 0-134: Results obtained from the 3 accelerograms with maximum SD in time domain

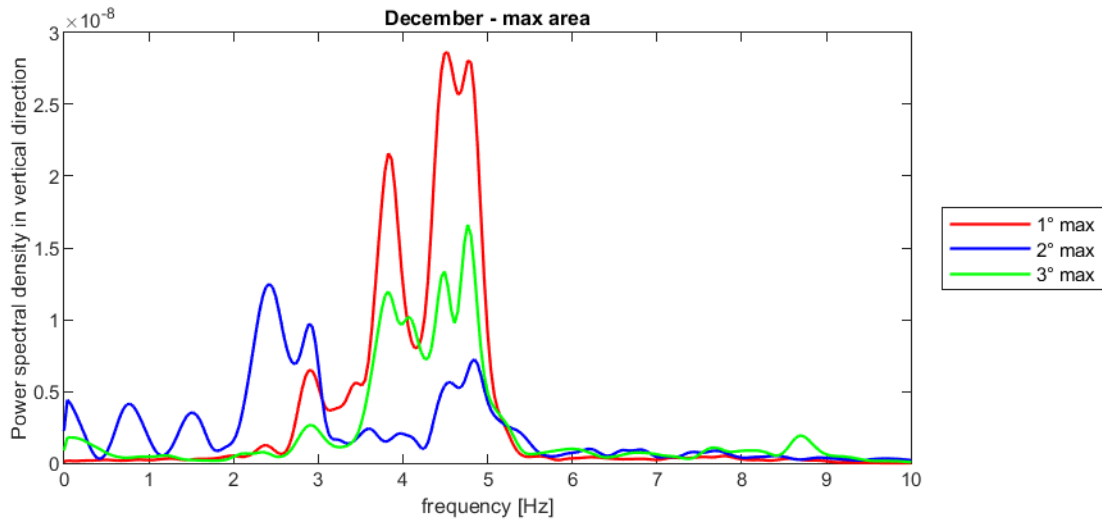

Figure 0-135: Results obtained from the 3 accelerograms with maximum area of PSD

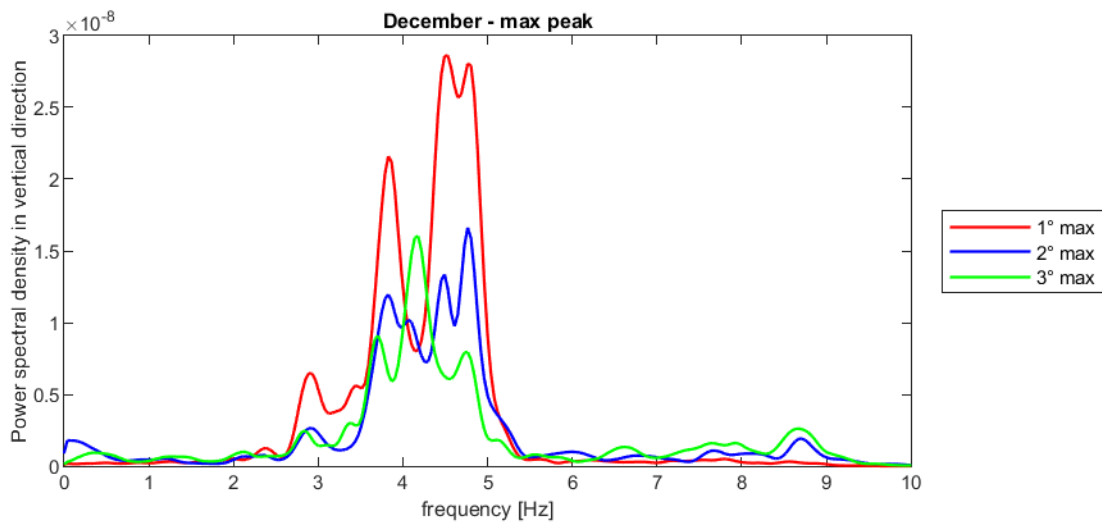

Figure 0-136: Results obtained from the 3 accelerograms with highest peak if PSD

Monitoring activity on Fiorenza Node of A4 Highway

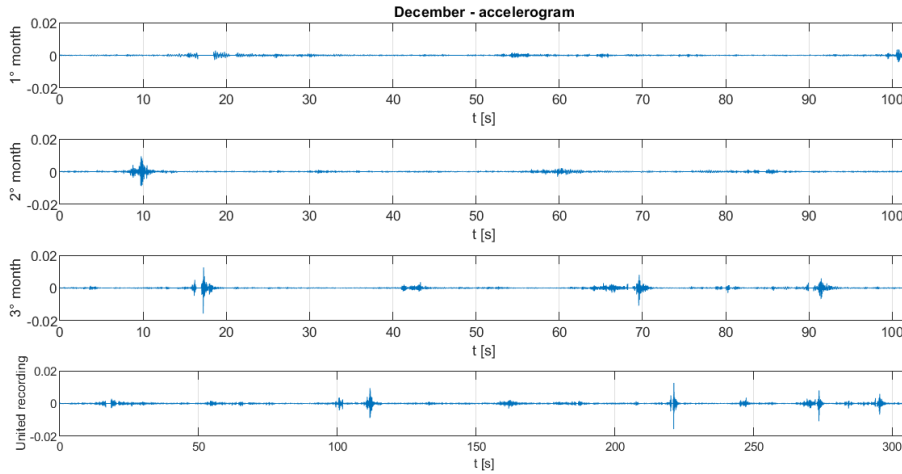

Figure 0-137: Accelerograms in vertical (x) direction with maximum standard deviation in time domain

10.12.2 Longitudinal direction (y)

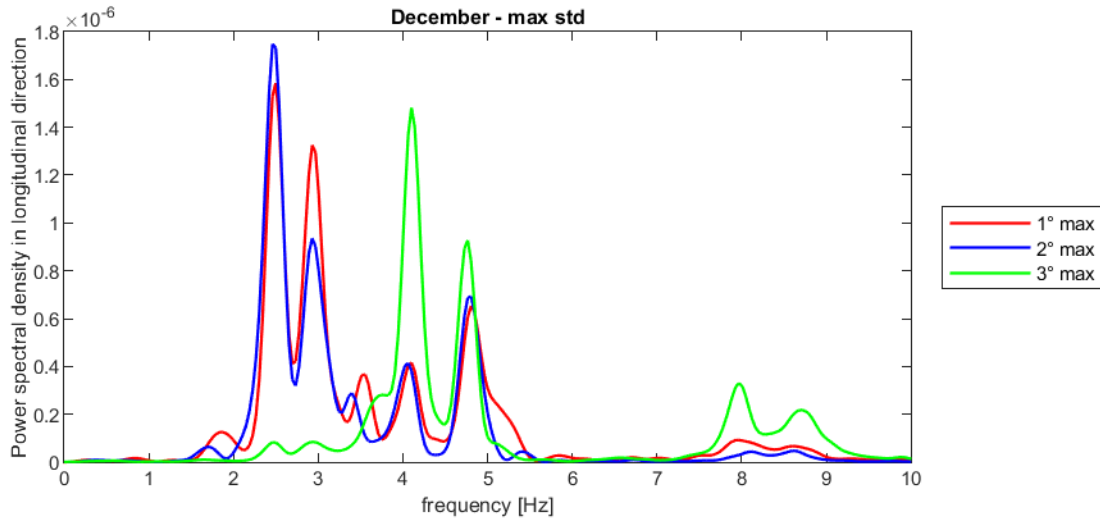

Figure 0-138: Results obtained from the 3 accelerograms with maximum SD in time domain

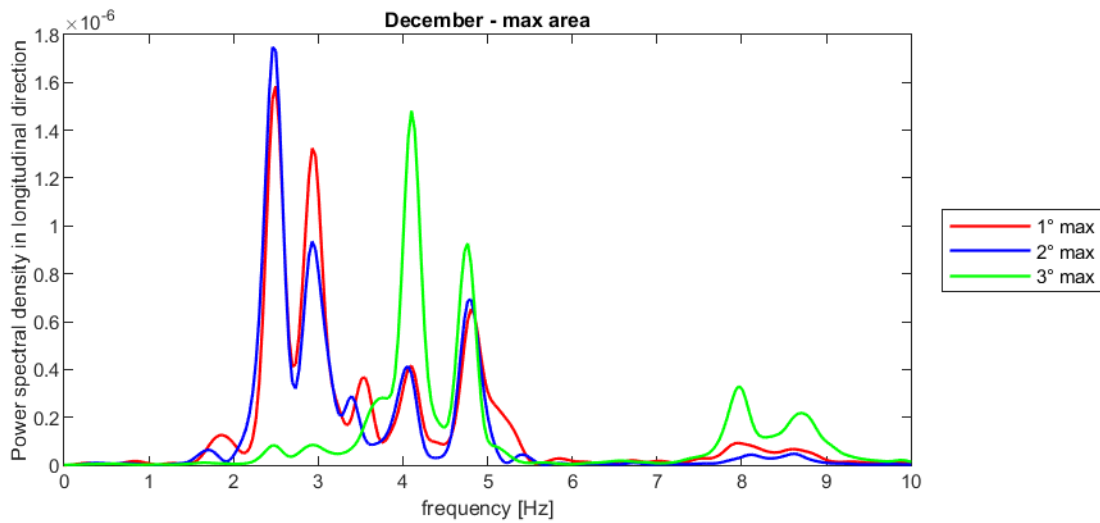

Figure 0-139: Results obtained from the 3 accelerograms with maximum area of PSD

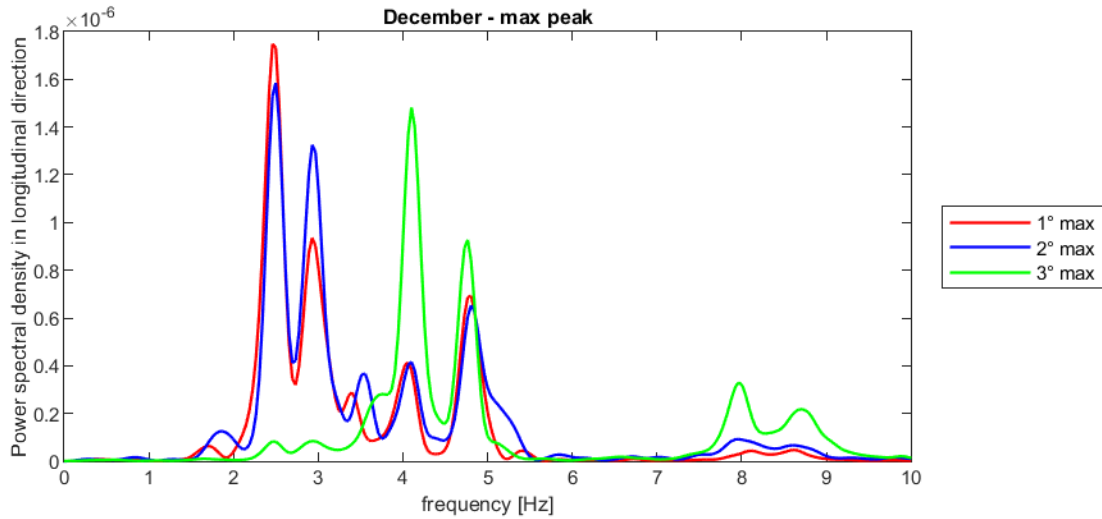

Figure 0-140: Results obtained from the 3 accelerograms with highest peak if PSD

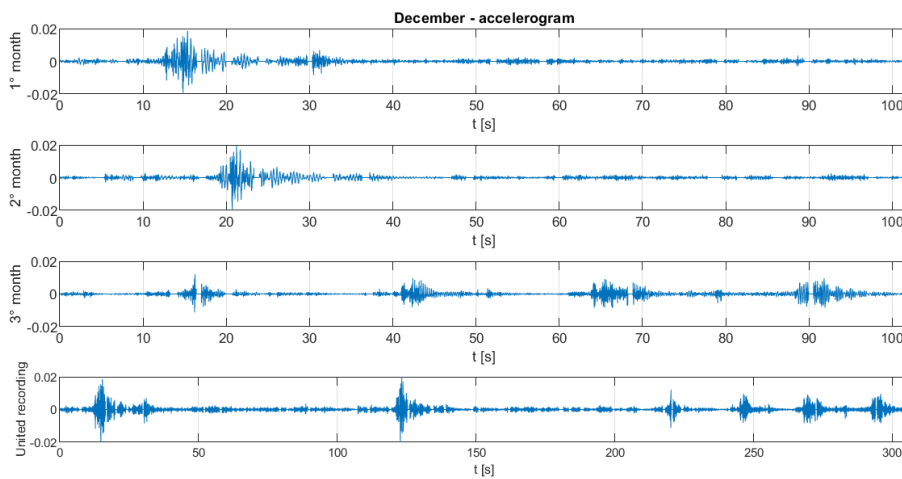

Figure 0-141: Accelerograms in longitudinal (y) direction with maximum standard deviation in time domain

10.12.3 Transverse direction (z)

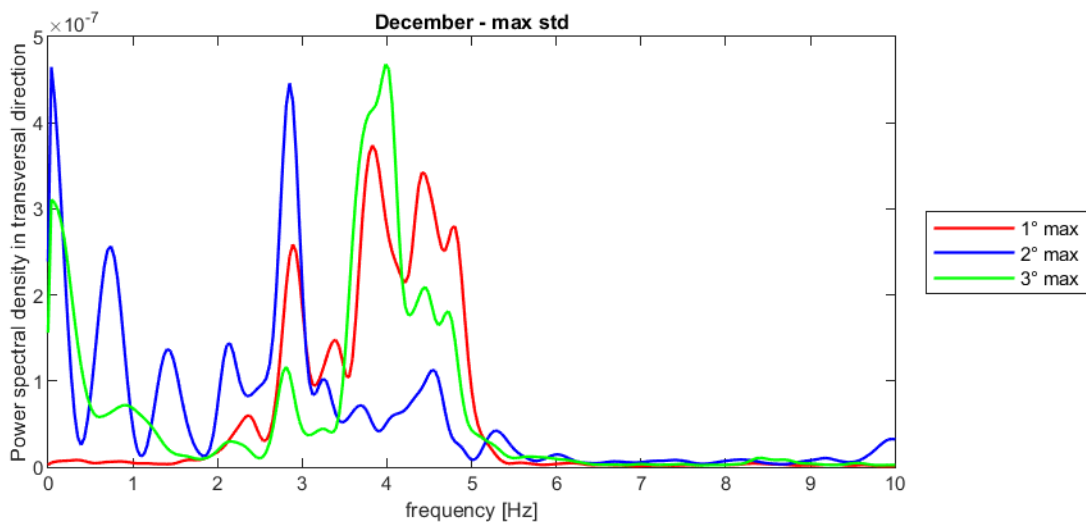

Figure 0-142: Results obtained from the 3 accelerograms with maximum SD in time domain

Monitoring activity on Fiorenza Node of A4 Highway

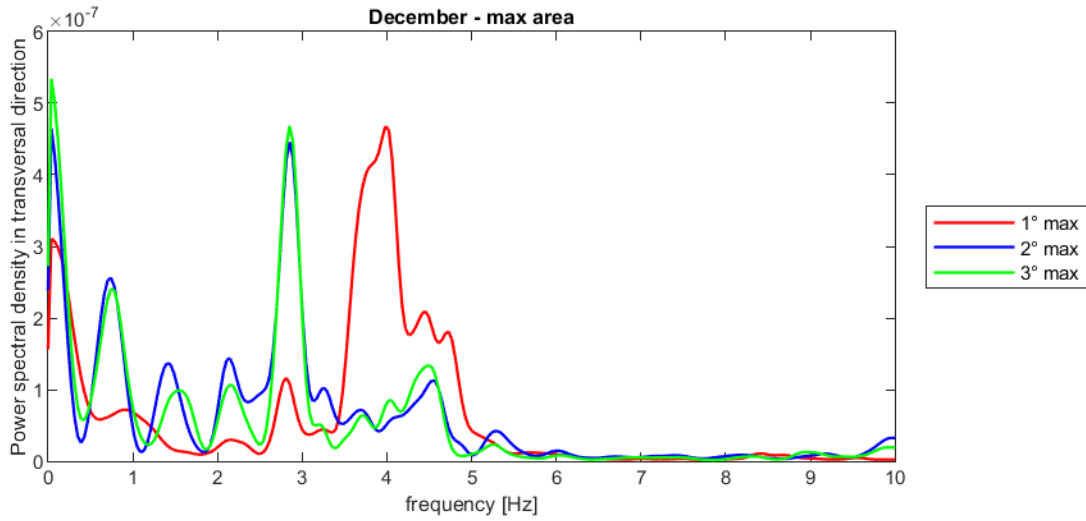

Figure 0-143: Results obtained from the 3 accelerograms with maximum area of PSD

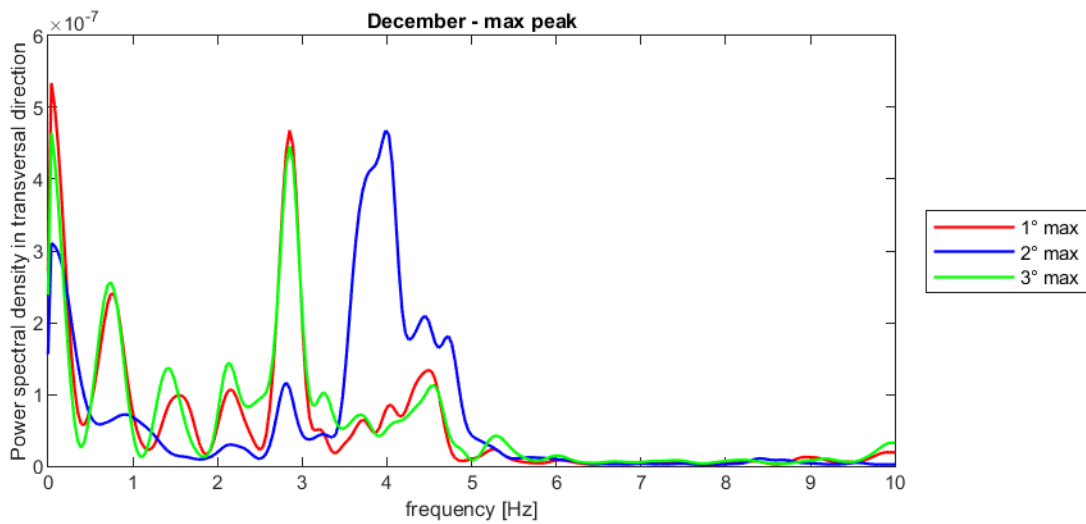

Figure 0-144: Results obtained from the 3 accelerograms with highest peak if PSD

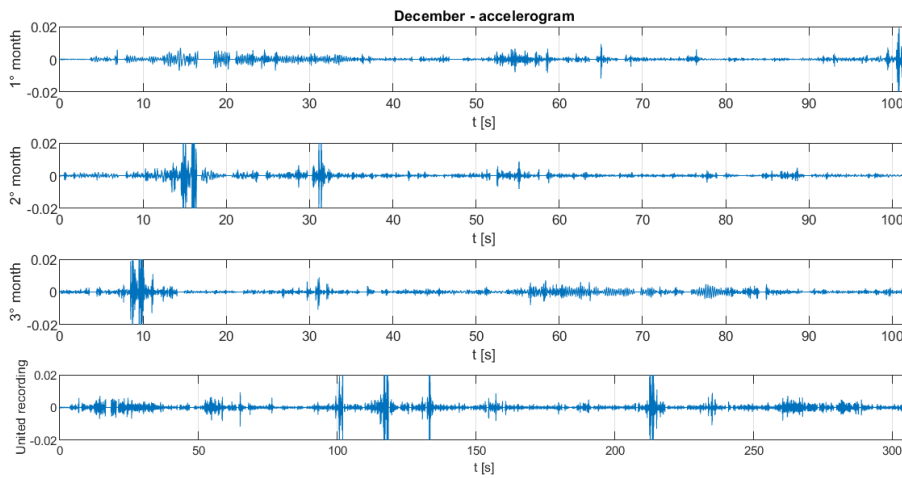

Figure 0-145: Accelerograms in transverse (z) direction with maximum standard deviation in time domain

10.13 Analysis of the complete 2023 year

All the obtained frequencies have been now classified and represented in such a way to obtain the variation of the values during the year. So, the peaks value has been separated and the representation for the vertical, longitudinal and transverse direction have been obtained.

Table 0-37: Main identified frequencies for sensor 319E3 – bridge 223 – Sp2 – P2E

	Vertical direction				Longitudinal direction				Transverse direction				
	1° peak	2° peak	3° peak	4° peak	1° peak	2° peak	3° peak	4° peak	1° peak	2° peak	3° peak	4° peak	
Numerosity	38	92	94	93	97	85	100	103	69	102	88	94	
MEAN	2.23	2.80	3.90	4.64	2.46	2.89	4.03	4.72	2.16	2.82	3.68	4.40	
SD	0.12	0.07	0.24	0.16	0.03	0.04	0.09	0.08	0.10	0.08	0.13	0.18	
C.o.V.	5.4%	2.5%	6.0%	3.4%	1.2%	1.5%	2.3%	1.7%	4.8%	2.8%	3.7%	4.2%	
Rating	28%	84%	67%	79%	98%	84%	93%	100%	53%	91%	73%	76%	
1	gen-23		4.1	4.65	2.5	2.97	4.14	4.8		2.85	3.71	4.38	
2	gen-23		2.81	4.21	4.77	2.46	2.97	4.1	4.84	2.1	2.81	3.83	
3	gen-23	2.15		4.1		2.5		4.1	4.84		2.85	4.02	
1	gen-23			4.1	4.65	2.46	2.93	4.14	4.8		2.81	3.67	4.38
2	gen-23	2.14		4.1		2.46	2.93	4.1	4.8		2.85		4.38
3	gen-23		2.81		4.73	2.5		4.06	4.73	2.1	2.81	3.83	4.3
1	gen-23			4.14	4.84	2.46	3.01	4.14	4.8		2.81	3.67	4.34
2	gen-23			4.1	4.65	2.48		4.14	4.84	2.07	2.81	3.83	4.34
3	gen-23	2.19		4.1		2.46	3.01	4.14	4.84		2.85	3.83	
1	feb-23		2.54	3.83	4.73	2.5	2.85	4.1	4.8	1.91	3.12	3.79	4.53
2	feb-23		2.81	3.98	4.77	2.5	2.89	4.06	4.77		2.81	3.79	4.73
3	feb-23		2.81	4.06	4.8	2.5	2.97	4.02	4.73	2.27	2.77	3.83	4.73
1	feb-23		2.81	4.06	4.8	2.5	2.89	4.06	4.8		3.12	3.79	4.53
2	feb-23		2.54	3.83	4.73	2.46	2.89	4.06	4.77	2.03	2.81	3.79	4.49
3	feb-23		2.81	4.06	4.77	2.5	2.96	4.02	4.73	2.26	2.81	3.83	4.77
1	feb-23		2.54	3.83	4.77	2.5	2.89	4.06	4.73	2.34	2.81	3.83	4.73
2	feb-23		2.81	4.06	4.8	2.5	2.97	3.98	4.73		2.81	4.01	4.77
3	feb-23		2.81	4.06	4.8	2.5	2.89	4.06	4.77		2.81	3.79	
1	mar-23		2.81	3.91	4.65	2.46	2.85	4.06	4.65	2.19	2.89	3.79	
2	mar-23		2.81	4.15		2.5		4.06	4.73	2.19	2.81	3.55	4.26
3	mar-23		2.81	4.06		2.46	2.89	4.1	4.73		2.81	3.78	4.38
1	mar-23		2.81	3.91	4.65	2.46	2.85	4.06	4.65	2.19	2.89	3.79	
2	mar-23		2.81	4.15		2.46		4.06	4.73	2.15	2.85	3.55	4.26
3	mar-23		2.81	4.06		2.42	2.89	4.1	4.73		2.81		4.3
1	mar-23		2.81	4.15		2.46	2.85	4.06	4.65	2.18	2.89	3.79	4.22
2	mar-23		2.81	3.91	4.65	2.46		4.02	4.73	2.15	2.81	3.55	4.26
3	mar-23			4.1	4.61	2.46	2.89	4.1	4.73		2.81		4.3
1	apr-23		2.93	4.33	4.77	2.46	2.93	4.06	4.8	1.95	2.89	3.71	4.22
2	apr-23	2.23	2.69	3.94	4.65		2.89	4.06	4.65		2.77	3.59	4.22
3	apr-23		2.77	4.22		2.42		3.9	4.61	2.14	2.93	3.63	4.57
1	apr-23		2.89	4.33	4.77	2.46	2.93	4.02	4.8	1.95	2.89	3.71	
2	apr-23	2.23	2.73	3.91	4.65	2.42	2.89	4.02	4.65		2.77	3.59	4.22
3	apr-23		2.77	4.22		2.42		3.91	4.65	2.14	2.93	3.63	4.57

Monitoring activity on Fiorenza Node of A4 Highway

1	apr-23		2.77	4.21		2.46	2.93	4.02	4.8	1.95	2.89	3.71	
2	apr-23		2.93	4.33	4.77	2.46	2.89	4.02	4.65		2.77	3.59	4.22
3	apr-23	2.23	2.73	3.91	4.65	2.46		4.02	4.69	2.15	2.93		4.61
1	mag-23	2.29	2.77	3.83	4.45	2.46	2.85	4.02	4.77	2.18	2.73	3.79	4.65
2	mag-23	2.1	2.77		4.65	2.42	2.85		4.73	2.1	2.77	3.55	4.65
3	mag-23		2.77	3.6		2.5		4.06	4.65	2.3	2.77	3.48	4.77
1	mag-23	2.29	2.77	4.14	4.49	2.46	2.89	4.02	4.77	2.15	2.73	3.79	4.49
2	mag-23	2.1	2.77	4.21	4.65	2.46	2.85		4.65	2.1	2.77		4.61
3	mag-23		2.81	3.95	4.73	2.5		4.06	4.73		2.77	3.71	
1	mag-23	2.29	2.77	3.82	4.49	2.46	2.89	4.02	4.77	2.07	2.77		4.18
2	mag-23	2.1	2.77		4.65	2.46	2.85		4.65	2.23	2.73		4.18
3	mag-23		2.81	3.95	4.73	2.5		4.06	4.73	2.23	2.81		4.34
1	giu-23		2.73	4.1	4.49	2.42	2.85	3.87	4.65	2.07	2.77	3.52	4.09
2	giu-23	2.29	2.81		4.77	2.46		4.06	4.84	2.26	2.77	3.63	
3	giu-23			3.91	4.73	2.46	2.89	4.06	4.61			3.71	4.73
1	giu-23		2.73	4.1	4.49	2.42	2.85	3.87	4.65	2.07	2.77	3.52	4.09
2	giu-23		2.81		4.77	2.46		4.06	4.84	2.23	2.77	3.55	
3	giu-23		2.77	3.71	4.73	2.46	2.85	4.06	4.61			3.71	4.73
1	giu-23		2.73	4.1	4.49	2.46		4.06	4.8	2.1	2.77	3.52	4.09
2	giu-23		2.77		4.73	2.42	2.85	3.87				3.71	4.73
3	giu-23	2.29	2.77	3.91	4.45	2.46	2.89	4.06	4.69	2.26	2.77	3.63	
1	lug-23	2.1	2.77	3.98	4.69	2.38	2.85	4.02	4.69	2.07	2.77	3.67	4.38
2	lug-23	2.3	2.77	4.14		2.38	2.81	3.79	4.77	2.3	2.77		4.14
3	lug-23	2.38	2.85	4.18	4.88	2.42	2.81	4.06	4.84		2.73	3.67	4.26
1	lug-23	2.1	2.77	3.98	4.69	2.38	2.89	4.02	4.69	2.07	2.77	3.71	4.38
2	lug-23	2.3	2.77	4.14	4.84	2.38	2.85	3.79	4.77	2.3	2.77		4.14
3	lug-23	2.38	2.85	4.14	4.86	2.42	2.85	4.06	4.84	2.34	2.7	3.67	4.26
1	lug-23	2.3	2.77	4.14	4.84	2.42		4.14		2.3	2.77	3.36	4.34
2	lug-23		2.77	3.98	4.69	2.38	2.85	4.02	4.69	2.07	2.77		4.14
3	lug-23		2.73	4.14		2.42	2.85	4.06	4.84	2.07	2.73		4.34
1	ago-23	2.29	2.77	4.02	4.69	2.42	2.89	4.06	4.45		3.08		4.84
2	ago-23	2.34	2.77	3.55	4.53	2.46	2.89	4.02	4.65	2.3	2.73	3.55	4.53
3	ago-23	2.34		3.83	5	2.46	2.89	4.02	4.69		2.81	3.55	4.69
1	ago-23	2.34	2.77	3.55	4.53	2.42	2.89	4.06	4.49		3.08		
2	ago-23	2.3			4.34	2.46	2.89	4.02	4.65	2.3	2.73	3.55	4.53
3	ago-23	2.29	2.77	3.83	4.69	2.5	2.89	4.02	4.73	2.3	2.92	3.59	4.38
1	ago-23	2.3	2.81	3.55	4.53	2.46	2.85	4.06	4.45	2.34	2.73	3.55	4.53
2	ago-23		2.81	3.6	4.65		2.89	3.91	4.73		2.81	3.55	4.69
3	ago-23		2.81	3.55		2.46		4.06	4.57	2.34	2.93	3.55	4.38
1	set-23		2.77	3.48	4.34		2.85	4.02	4.61		2.77	3.52	4.29
2	set-23		2.77	3.59	4.73	2.46	2.85	4.14	4.65	2.23	2.81	3.55	4.29
3	set-23		2.77		4.65		2.81	4.06	4.69		2.77	3.59	4.38
1	set-23		2.77	3.43	4.34		2.85	4.02	4.65		2.77	3.52	4.29
2	set-23		2.73	3.59	4.72		2.81	4.14	4.65	2.23	2.81	3.55	4.29
3	set-23		2.73		4.65	2.46	2.85	4.06	4.65	2.07	2.77	3.59	4.38
1	set-23		2.77		4.34		2.85	4.14	4.65		2.77	3.59	4.3
2	set-23		2.77	3.59	4.73			4.06	4.73		2.77	3.48	4.3
3	set-23		2.89	3.59	4.41		2.85	4.02	4.61	2.11	2.77	3.59	
1	ott-23	2.1	2.81	3.55	4.53	2.46	2.93		4.73	2.18	2.93	3.55	4.26

Monitoring activity on Fiorenza Node of A4 Highway

2	ott-23		2.85	3.55	4.26	2.46	2.93	4.02	4.73	2.15	2.81	3.71	4.26
3	ott-23			3.83	4.53	2.46	2.89	3.98	4.69	2.34	2.85	3.79	4.45
1	ott-23	2.38	2.85	3.59	4.3	2.46	2.93		4.77	2.18	2.93	3.55	4.26
2	ott-23	2.1	2.81	3.59	4.53	2.46	2.89	3.98	4.69	2.14	2.81	3.71	4.26
3	ott-23			3.83	4.53	2.46	2.93	4.02	4.73	2.14	2.93	3.55	4.29
1	ott-23			3.83	4.53	2.46	2.93	4.02	4.73			3.83	4.53
2	ott-23		2.85	3.55	4.36	2.46		4.06	4.73	2.19	2.93	3.55	4.3
3	ott-23	2.29	2.89		4.45	2.42		4.02	4.69	2.19	2.93	3.71	4.26
1	nov-23	1.95	2.77	3.55	4.34	2.46	2.89	3.83			2.77	3.59	4.25
2	nov-23		2.81	3.59	4.45	2.46	2.89	3.63	4.77	2.07	2.81	3.59	4.34
3	nov-23		2.81		4.57	2.46	2.89		4.69			3.75	4.22
1	nov-23	1.95	2.77	3.55	4.34	2.46	2.89	3.87			2.77	3.59	4.25
2	nov-23		2.81	3.59	4.45	2.46	2.89	3.63	4.77				4.22
3	nov-23				4.57	2.46	2.89		4.69	2.07	2.81	3.59	4.34
1	nov-23		2.81	3.67	4.57	2.42		4.1	4.77		2.77	3.59	4.26
2	nov-23	1.95	2.77	3.55	4.34	2.46	2.89	4.06		1.99	2.81		4.49
3	nov-23			3.69	4.53	2.46	2.89		4.65		2.85	3.75	4.26
1	dic-23	2.34	2.89	3.83	4.8	2.5	2.93	4.1	4.84	2.34	2.89	3.83	4.41
2	dic-23		2.89	3.83	4.77	2.46	2.93	4.1	4.84	2.15	2.85		4.53
3	dic-23		2.89	3.71	4.77			4.1	4.77	2.15	2.81	3.98	4.45
1	dic-23		2.89	3.82	4.77	2.5	2.93	4.06	4.8		2.85	3.75	4.45
2	dic-23	2.29	2.89		4.84	2.46	2.93	4.06	4.8	2.15	2.85		4.53
3	dic-23		2.93	3.82	4.77			4.1	4.77	2.15	2.85		4.49
1	dic-23	2.34	2.89	3.83	4.8	2.46	2.93	4.1	4.77	2.15	2.85	4.02	4.49
2	dic-23		2.93	3.83	4.77	2.5	2.93	4.1	4.8		2.81	3.98	4.45
3	dic-23		2.89	3.71	4.77	2.46	2.93	4.1	4.77	2.15	2.85		4.53

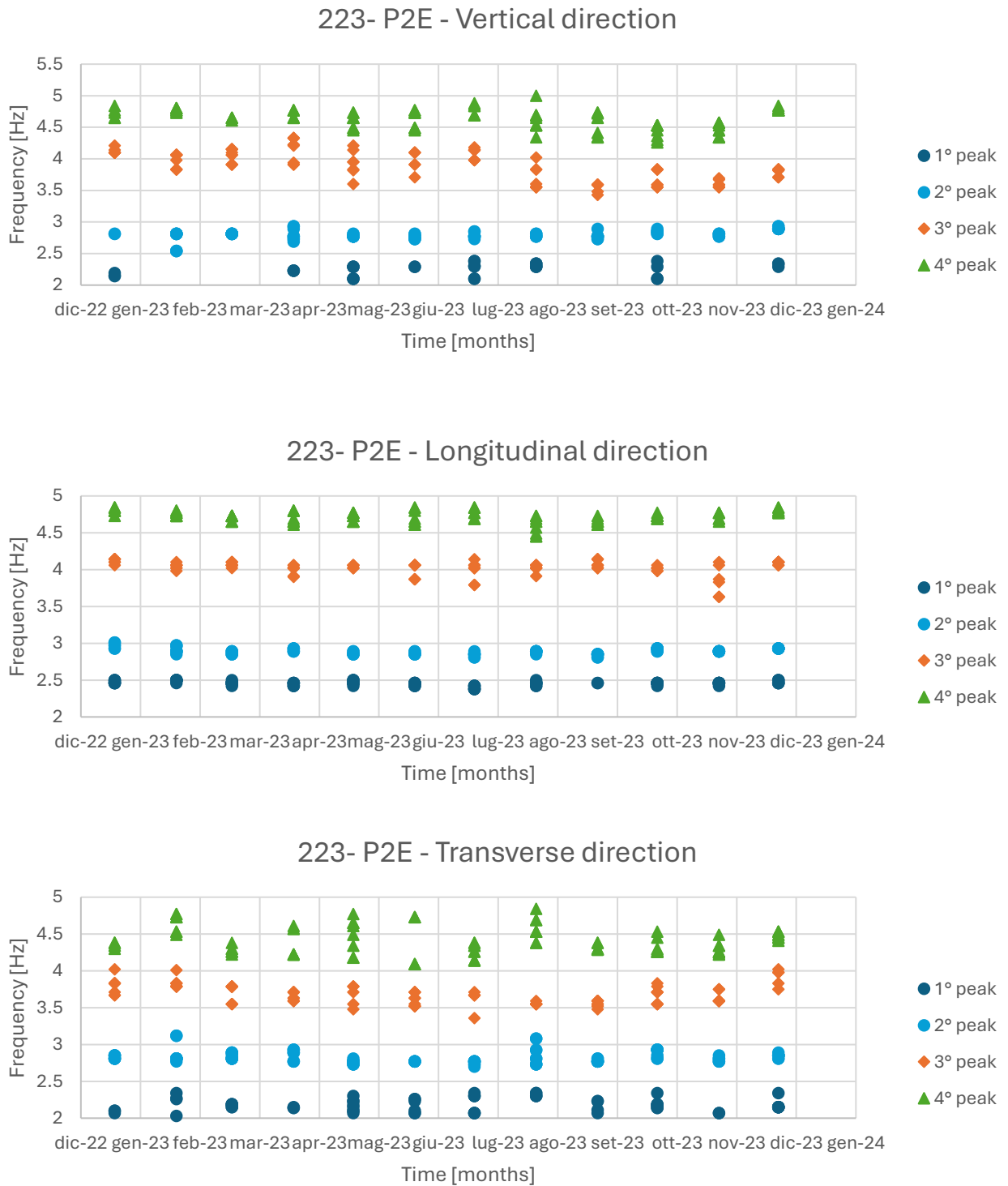

Figure 0-146: Main identified frequencies for sensor 319E3 – bridge 223 – Sp2 – P2E

10.14 Anomalies detection

Sensor 319E3 shows evident frequency anomalies along all the 2023 year.

Beside the frequencies shown in Table 0-37, that are regular and belong to the standard behavior of these decks, lower frequencies are found only for this sensor. These lower frequencies are found in vertical and transverse directions and are presented in Table 0-38.

The anomaly frequencies may suggest the presence of a damage on the pier, being the frequencies lower than the natural ones of the sound element.

Table 0-38: Frequency anomalies for sensor 319E3 – bridge 223 – Sp2 – P2E

	Frequency anomalies		
	Vertical	Transverse	
Numerosity	22	53	57
MEAN	0.56	0.27	0.95
SD	0.38	0.24	0.27
C.o.V.	67.0%	91.4%	28.3%
Rating	3%	6%	17%

1	gen-23	0.47	0.48	1.4
2	gen-23		0.43	1.13
3	gen-23		0.31	
1	gen-23	0.47	0.47	1.44
2	gen-23		0.42	
3	gen-23		0.47	1.13
1	gen-23		0.47	1.33
2	gen-23	0.47	0.43	1.17
3	gen-23			
1	feb-23		0.04	0.59
2	feb-23		0.04	0.86
3	feb-23	0.78		
1	feb-23	0.78		0.59
2	feb-23		0.04	0.86
3	feb-23		0.23	0.93
1	feb-23			
2	feb-23			
3	feb-23	0.78	0.04	0.86
1	mar-23			
2	mar-23			0.82
3	mar-23			0.51
1	mar-23			
2	mar-23			0.85
3	mar-23			0.39
1	mar-23			
2	mar-23			0.85

Monitoring activity on Fiorenza Node of A4 Highway

3	mar-23		0.39	1.29
1	apr-23		0.39	1.13
2	apr-23		0.63	
3	apr-23		0.7	1.37
1	apr-23	0.39	0.39	1.09
2	apr-23	0.66		
3	apr-23		0.7	1.33
1	apr-23		0.39	1.09
2	apr-23			
3	apr-23		0.7	1.41
1	mag-23			
2	mag-23			0.78
3	mag-23		0.04	0.66
1	mag-23			
2	mag-23		0.04	0.66
3	mag-23		0.04	1.01
1	mag-23			0.7
2	mag-23			
3	mag-23		0.08	0.78
1	giu-23		0.31	0.98
2	giu-23	0.9		
3	giu-23			
1	giu-23		0.31	0.98
2	giu-23	0.86		
3	giu-23		0.31	0.98
1	giu-23			
2	giu-23			
3	giu-23			
1	lug-23		0.39	1.09
2	lug-23			
3	lug-23			0.86
1	lug-23			0.39
2	lug-23			
3	lug-23	0.04	0.04	0.86
1	lug-23		0.39	1.13
2	lug-23	0.04		
3	lug-23			
1	ago-23	1.05	0.04	1.02
2	ago-23			
3	ago-23	1.01		
1	ago-23		0.04	1.02
2	ago-23	1.05		
3	ago-23	1.05		
1	ago-23			
2	ago-23		0.31	
3	ago-23	0.47		
1	set-23			

Monitoring activity on Fiorenza Node of A4 Highway

2	set-23			
3	set-23			
1	set-23		0.66	
2	set-23		0.78	1.33
3	set-23			
1	set-23			
2	set-23			
3	set-23			
1	ott-23		0.04	0.74
2	ott-23		0.04	0.82
3	ott-23			
1	ott-23	0.04	0.04	0.74
2	ott-23	0.04	0.04	0.86
3	ott-23		0.04	0.59
1	ott-23			
2	ott-23		0.04	0.74
3	ott-23		0.04	0.86
1	nov-23			
2	nov-23			
3	nov-23		0.04	0.9
1	nov-23	0.98		0.98
2	nov-23		0.12	0.9
3	nov-23		0.12	0.94
1	nov-23			
2	nov-23			
3	nov-23			
1	dic-23			
2	dic-23		0.04	0.74
3	dic-23		0.04	
1	dic-23			
2	dic-23	0.04	0.74	1.4
3	dic-23	0.04	0.74	1.56
1	dic-23		0.04	0.74
2	dic-23		0.04	
3	dic-23		0.04	0.74