

POLITECNICO DI TORINO  
SECOND SCHOOL OF ARCHITECTURE  
Master of Science in Architecture  
***Honors theses***

---

**KINETIC ORIGAMI. Architectural Applications**

by Davide Speranza

Tutor: Giuseppe Andrea Ferro

This thesis project has sought to highlight the significance of the origami and its possible implications in architecture.

Through a historical analysis of its evolution has been possible to deduce that the origami, as understood today, is the product of a slow maturation process that lasted centuries, from a ceremonial activity restricted to a closed audience, the origami is become a free hobby characterized by recreational, artistic and scientific aspects.

This implies that the origami can be studied in many and different way.

The present work has focused attention on the kinetic origami and its ability to change shape through a transformation process.

This phenomenon is represented by the *folding pattern* through the fold act: the deformation of a piece of sheet until the creation of a linear sign, who is called a fold line.

Although this may seem like a not useful concept, this act contains remarkable geometric and kinematic implications that can give the opportunity to explore a set of concepts related to the application of origami in architecture.

For do this it has developed a basic background related to theoretical mechanics applied to machines and on geometry of origami.

In this way it was possible to study a particular fold called "knee-fold", through the construction of its algorithm with Grasshopper: a plug-in for Rhinoceros.

With simple geometric steps, it was possible to replicate the behavior of this fold and apply it to the case study of a kinematic roofing of a tennis court.

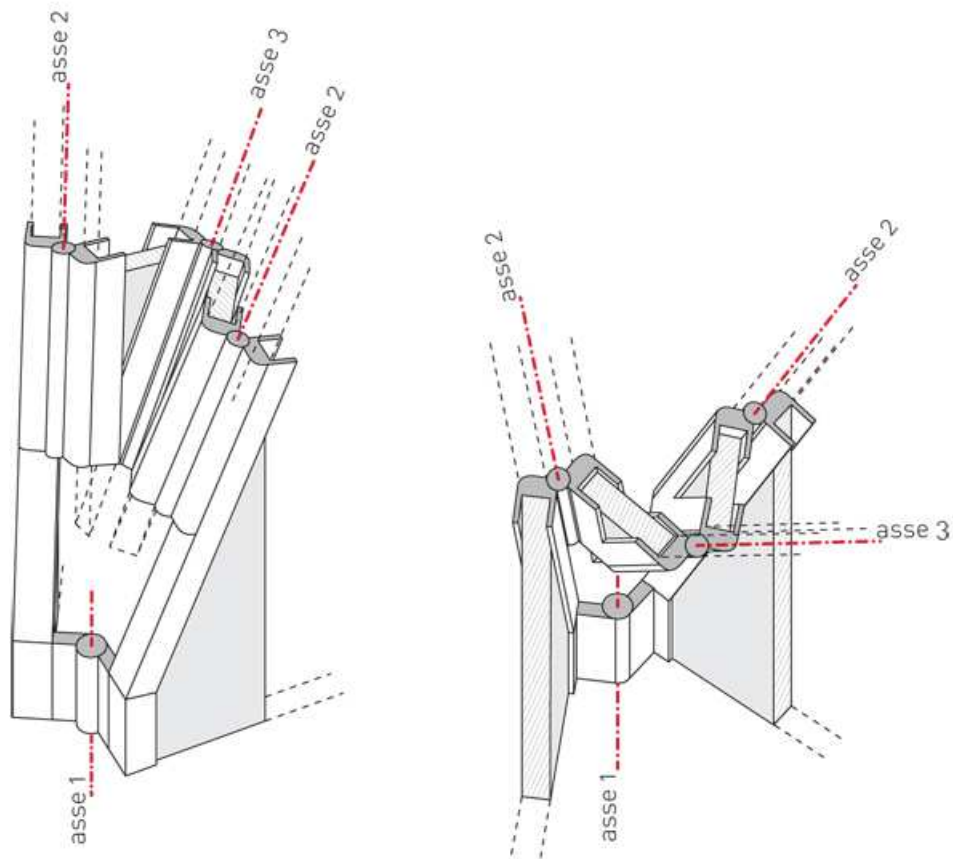

*Representation of the various steps needed to make a knee-fold*

The study of the form, the definition of the mechanisms and the objectification of the origami has allowed to highlight various comments with regard to its actual use in architecture

The first of these is related to the design process, because unlike a “classic” architectural project in the case of origami takes over the issue of his movement. The structure, being subject to a linkage is not due to a static element so it cannot be associated to the normal mental processes undertaken for the realization of a project, it requires a parallel study of the geometry and movement.

Another observation is related instead on the “physicalness” of the origami: the application of the thick on the folds brings a series of problems due to the passage the motion study from a two-dimensional objects to a three-dimensional objects. This leads to a focus on mechanisms to be used, what could it function as a simple hinge mechanism can become a much more complex and more difficult to achieve.

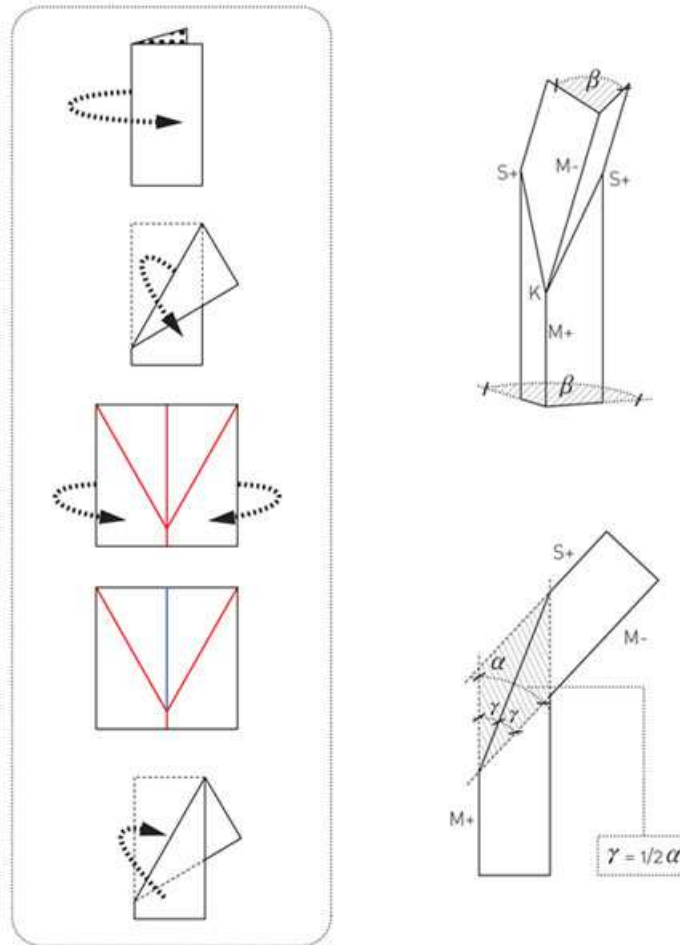

*Axonometric projection of the node joining the knee-fold*

If you add to these observations the study of stresses due to external loads, we are faced with a complex object, structured on many variable elements characterized by a strong interconnection.

In this thesis we tried to solve most of these issues, focusing particularly on the control of the kinematics and mechanics of the various elements.



*Complete development of the roofing*

A possible future development of the thesis work could be the prototyping of the scaled roofing in order to analyze the static behavior under stress and its compared to others structures with similar function.

For further information, e-mail:  
Davide Speranza: [dav.speranza@gmail.com](mailto:dav.speranza@gmail.com)