

**Cooperative Traffic Control Solution for Vehicle Transition from Autonomous to
Manual Mode exploiting Cellular Vehicle-to-Everything (C-V2X) Technology**

By

Stefano Caserini

A Thesis

Submitted to the Faculty of Graduate Studies
through the Department of Mechanical, Automotive and Materials Engineering
in Partial Fulfillment of the Requirements for
the Degree of Master of Applied Science
at the University of Windsor

Windsor, Ontario, Canada

2019

© 2019 Stefano Caserini

**Cooperative Traffic Control Solution for Vehicle Transition from Autonomous to
Manual Mode exploiting Cellular Vehicle-to-Everything (C-V2X) Technology**

by

Stefano Caserini

APPROVED BY:

C. Lee

Department of Civil and Environmental Engineering

J. Ahamed

Department of Mechanical, Automotive and Materials Engineering

Y.H. Kim, Advisor

Department of Civil and Environmental Engineering

J. Johrendt, Co-Advisor

Department of Mechanical, Automotive and Materials Engineering

September 20, 2019

DECLARATION OF ORIGINALITY

I hereby certify that I am the sole author of this thesis and that no part of this thesis has been published or submitted for publication.

I certify that, to the best of my knowledge, my thesis does not infringe upon anyone's copyright nor violate any proprietary rights and that any ideas, techniques, quotations, or any other material from the work of other people included in my thesis, published or otherwise, are fully acknowledged in accordance with the standard referencing practices. Furthermore, to the extent that I have included copyrighted material that surpasses the bounds of fair dealing within the meaning of the Canada Copyright Act, I certify that I have obtained a written permission from the copyright owner(s) to include such material(s) in my thesis and have included copies of such copyright clearances to my appendix.

I declare that this is a true copy of my thesis, including any final revisions, as approved by my thesis committee and the Graduate Studies office, and that this thesis has not been submitted for a higher degree to any other University or Institution.

ABSTRACT

Nowadays, automated vehicles represent a promising technology to face the stringent requirements for safety and traffic efficiency in the automotive environment. Driving responsibilities will be gradually addressed to the machine, and the role of human pilots will be progressively reduced to passengers. The interaction between passengers and the automated system will create different risks that have not been considered in the past. In particular, the transition between autonomous and manual mode is understood as a risky situation. During the transition, the driver manifests driving irregularities and loss of situation awareness that may endanger himself and other participants on the road. Hence, the vehicle transitioning needs a higher quantity of space around it to be considered safe.

However, no effective solution has been developed yet. This thesis aims to design a cooperative traffic control solution that will manage the movements of the group of vehicles to increase the free space around the one transitioning. It will exploit another tool that will play a fundamental role in the future of the automotive industry: connected vehicles technology. C-V2X technology will create a medium for vehicles to exchange information and cooperate. A controller managing the cooperation between vehicles has been developed to help a smooth and safe vehicle repositioning. The controller will be positioned in a centralized computing facility and it will communicate with all the vehicles. The controller defines rules to move vehicles together and enlarge the free space around the vehicle transitioning without collisions. The rules are modeled by a spring-mass-damper system, that can be exploited to control the longitudinal behavior of automated vehicles. In particular, the spring-mass-damper system can manage smooth migration between vehicle dispositions without oscillations.

A computer simulation is used to test the performance of the proposed traffic control system. The simulation environment is constituted by three main components: traffic flow, controller and communication network. It has been tested with the software VEINS, which provides interaction between a network simulator (OMNeT++) and a traffic simulator (SUMO). The traffic flow represents the interactions between vehicles. The controller analyzes the data and sends control messages to all vehicles. The communication network will share the data concerning vehicles' position and speed and control messages.

The proposed cooperative vehicle control system demonstrated to reduce the risks of the transition with the smooth motion of vehicles. The controller is able to achieve the safety requirements without reducing the level of comfortability of vehicles' passengers.

TABLE OF CONTENTS

DECLARATION OF ORIGINALITY	iii
ABSTRACT	iv
LIST OF TABLES	vii
LIST OF FIGURES	viii
LIST OF ABBREVIATIONS	x
1 Introduction.....	1
1.1 Background	1
1.2 Scope of the research	2
1.3 Thesis Contribution.....	3
1.4 Thesis Outline	4
2 Literature Review.....	5
2.1 Automation Effects on Vehicles Equipped with both Manual and Autonomous Driving Modules	6
2.1.1 Automation Levels for the Automotive Industry	7
2.1.2 Automated Vehicles: Where They Stand Now?	9
2.1.3 Transition between Autonomous and Manual Modes.....	11
2.1.4 The Dual Processing Paradigm	12
2.1.5 Effects on Drivers	14
2.1.6 Solution Methods to the Issues of Vehicle Transition	15
2.2 Cooperation between Vehicles.....	18
2.2.1 Traffic Control-Based Solutions	18
2.2.2 Microscopic Traffic Model for Traffic Control	19
2.2.3 Technological Requirements for Cooperative Reaction: Connected Vehicles	23
2.2.4 DSRC	27
2.2.5 5G C-V2X.....	28
2.2.6 The Debate between DSRC and 5G C-V2X	35
2.2.7 Technological Requirements for Cooperative Reaction: Positioning Systems.....	36
3 Model.....	41
3.1 Model Workflow.....	41
3.2 Centralized Controller.....	46
3.2.1 Input Management	47
3.2.2 Definition of Vehicle's Relations.....	49
3.2.3 Proprieties of the relations	52
3.2.4 Output: Acceleration and Deceleration	64

3.3	Application Running in Vehicles	66
3.3.1	Intra-vehicle Computation Implementation	66
4	Simulation Models and Setup	69
4.1	SUMO	69
4.2	OMNeT++	70
4.3	SimuLTE.....	70
4.4	VEINS.....	71
4.5	Simulation Setup.....	71
4.5.1	Traffic Setup	71
4.5.2	Communication Network Setup.....	76
5	Simulation Results	81
5.1	Flexibility of the System when the Time Buffer is Varied	81
5.2	Evaluation of Safety and Comfort	85
5.3	Time Buffer equal to 16 s: Safe and Comfortable Operation	87
5.4	Time Buffer equal to 8 s: Safe Operation	91
6	Conclusions and Future Work.....	94
6.1	Conclusions.....	94
6.2	Future Work.....	95
	REFERENCES:	99
	VITA AUCTORIS	103

LIST OF TABLES

Table 1 DSRC use cases through V2V and V2I communication	27
Table 2 GNSS Error Sources [66].....	38
Table 3 Dynamic Memory Allocated for each Vehicle	49
Table 4 Data struct for vehicle relations	50
Table 5 Reaction Time in autonomous and manual mode and longitudinal distance at 36 m/s	55
Table 6 Numerical example for the definition of K_x	59
Table 7 Numerical example for the definition of K_n	61
Table 8 Numerical example for the definition of B_n	63
Table 9 Comfortability evaluation parameters with time buffer equal to 16 s	90
Table 10 Comfortability evaluation parameters with time buffer equal to 8 s	93

LIST OF FIGURES

Figure 2-1SAE levels of automation [9]	8
Figure 2-2 Roadmap of automated driving for passenger cars [11].....	10
Figure 2-3 Simplified schematic representation of Norman and Shallice's model on willed and automatic control of behavior [16]	13
Figure 2-4 Scheme of longitudinal matching zones for vehicles [22]	20
Figure 2-5 Usage Scenario of 2020 and beyond [52]	31
Figure 2-6 C-V2X communication modes.....	33
Figure 2-7 Sidelink operations mode 3 (network assisted) and mode 4 (self-managed) [57].....	34
Figure 2-8 How GPS works [67]	37
Figure 3-1 Model logical workflow	41
Figure 3-2 Longitudinal distance between automated a) and human-driven b) vehicles.....	43
Figure 3-3 Space/Speed/Acceleration evolution vs. time, following spring-damper system motion	43
Figure 3-4 Centralized Controller scheme for two vehicles	44
Figure 3-5 Scheme of disposition for high-density traffic before the transition a) and after b)	45
Figure 3-6 Scheme for the Centralized Controller for multiple vehicles	46
Figure 3-7 Force of the spring based on geometrical disposition a) and optimal behavior b).....	51
Figure 3-8 SMD system a) and constant time headway in SMD system b).....	53
Figure 3-9 Bidirectional and Unidirectional representation.....	54
Figure 3-10 Space allocated for a safe driving condition for an autonomous vehicle a) and a vehicle after transition b)	56
Figure 3-11 Space allocation before transition a) and after b).....	57
Figure 3-12 Repulsion and alignment zone scheme	58
Figure 3-13 Single lane speed-time analysis for critical damping a), overdamping b) and underdamping c) conditions.....	63
Figure 3-14 Single lane unidirectional relations a) and bidirectional relations b)	65
Figure 3-15 Variation of Spring Constant and Damping Coefficient	67
Figure 4-1 Example of SUMO configuration file	72
Figure 4-2 Example of an environment that can be created using NETEDIT	73
Figure 4-3 Example of .rou.xml routes file.....	74
Figure 4-4 Vehicle disposition before of transition detection.....	76
Figure 4-5 Cellular Network definition	77
Figure 4-6 Car module used in the simulation.....	78
Figure 4-7 Manager assignments within the initialization file.....	79
Figure 4-8 Example of .launchd.xml file	80
Figure 5-1 Area required by vehicle transitioning	81
Figure 5-2 Initial disposition a), risk detection b), final disposition c) in the simulated environment	82
Figure 5-3 Variation of relative longitudinal distance within the simulation time	83
Figure 5-4 Variation of speed vs. simulation time	83
Figure 5-5 Final speed of vehicle transitioning with different time buffers	84
Figure 5-6 Percentage of required space that is cleared at the end of the time buffer	85
Figure 5-7 Maximum Acceleration and Jerk registered with different time buffers	86
Figure 5-8 Variation of relative longitudinal distance within simulation time, time buffer equal to 16 s..	88
Figure 5-9 Variation of speed within simulation time, time buffer equal to 16 s	88
Figure 5-10 Acceleration vs. simulation time, time buffer equal to 16 s.....	89
Figure 5-11 Variation of relative longitudinal distance within simulation time, time buffer equal to 8 s..	91

Figure 5-12 Variation of speed within simulation time, time buffer equal to 8 s	91
Figure 5-13 Acceleration vs. simulation time, time buffer equal to 8 s.....	92
Figure 6-1 Cooperative ramp entrance maneuver	96
Figure 6-2 Example of intelligent lane changing scheme.....	98

LIST OF ABBREVIATIONS

3GPP	3 rd Generation Partnership Project
4G	4 th Generation
5G	5 th Generation
5GAA	5G Automotive Association
ACC	Adaptive Cruise Control
ADAS	Advanced Driver Assistance System
C-V2X	Cellular – V2X
CAV	Connected and Automated Vehicle
CES	Consumer Electronics Show
CSMA	Carrier Sense Multiple Access
CV	Connected Vehicle
DSRC	Dedicated Short-Range Communication
eMMB	Enhanced Mobile BroadBand
EPC	Evolved Packet Core
ETSI	European Telecommunication Standards Institute
EU	European Union
FCC	Federal Communication Commissions
IEEE	Institute of Electric and Electrical Engineers
INET	Internet Networking
IP	Internet Protocol
ITS	Intelligent Transportation System
KPI	Key Performance Indicator
LIDAR	LIght Detection and Ranging
LTE	Long Term Evolution
LTE-A	LTE- Advanced

GNSS	Global Navigation Satellite System
GPRS	General Packed Radio Service
GPS	Global Positioning System
GTP	GPRS Tunneling Protocol
MAC	Multiple Access Control
MEC	Multi-access Edge Computing
mMTC	Massive Machine Type Communication
MmWave	Millimeter-length electromagnetic waves
NED	Network Definition
NFV	Network Function Virtualization
NGNM	Next Generation Mobile Network
NHTSA	National Highway Traffic Safety Administration
PGW	Packet Data Network Gateway
PHY	Physical layer
PSA	Peugeot S.A.
RADAR	Radio Detection And Ranging
RAT	Radio Access Technology
SAE	Society of Automotive Engineers
SAS	Supervisory Attentional System
SDN	Software-defined networking
SMD	Spring-Mass-Damper
SUMO	Simulation of Urban MObility
TCP	Transmission Control Protocol
TRACI	TRAffic Control Interface
UDP	User Datagram Protocol
UE	User Equipment
URLLC	Ultra-Reliable Low-Latency Communication
V2I	Vehicle to Infrastructure

V2N	Vehicle to Network
V2P	Vehicle to Pedestrian
V2V	Vehicle to Vehicle
V2X	Vehicle to Everything
VEINS	Vehicles in Network Simulations
WAVE	Wireless Access in Vehicular Environment

1 Introduction

1.1 Background

Nowadays, self-driving cars represent an engineering problem that is being gradually solved. In the last decades, automation has been spreading inside the automotive environment. Ground vehicles are now supported by intelligent systems capable of controlling the longitudinal as well as the lateral behavior of the vehicle. In the past, these systems were thought as an aid to the pilot. The human was still in possession of all the responsibilities deriving by the vehicle behavior. The current scenario is showing a gradually decreased involvement of humans in the act of driving, and always more control is given in the hands of the autonomous systems. The positive outcomes are easily derived. Automated systems do not get tired, they are not subjected to lowered psychological performances, and they have a reaction time that vastly outperforms human reflexes. Hence, safety and traffic efficiency on our roads will be radically increased.

While the positive aspects of autonomous vehicles' introduction are vastly debated, less space has been given to the problematics arising. The functions addressed to human drivers are reduced with automation. With them, it will also be decreased the implicit and explicit attention that the drivers will give to the environment. From the literature, regarding also the experience collected by the aviation industry, one of the most severe problematics introduced with automation is the possibility to have an undesired transition from autonomous to manual driving modes. Experiments made on vehicle simulators show a highly irregular path of the vehicles when they are manually resumed after a long drive in autonomous mode. Moreover, drivers were subjected to dangerous behavior, such as not keeping a safe distance from the following vehicle or switching lane without gazing mirrors. The vehicle switching to manual mode thus develops risks for itself and other vehicles in its area.

In the next decade, it is foreseen that the penetration rate of autonomous vehicles will see a steep increment. The problematics related to handover, shown by a multitude of simulations and already experienced by the aviation industry, have convinced automakers to design proactive solutions. However, traditional solutions simply try to foresee the transition event. The prediction can be theoretically achieved by comparing data incoming from different sensors and stored map data. The discrepancy between these two sets of information will be an indicator of autonomous driving performance. The result is to provide the driver the largest amount of time as possible to gain control of the vehicle.

Simulations show that the problem cannot be entirely solved in this manner. Lene Harbott, the co-author of a study on vehicle transition conducted at Stanford University, underlines that even knowing about the change, a very different steering behavior and compromised performance are shown by the drivers.

The requirements of a transition are hence not limited to the prediction of the event. Erroneous steering behavior and lower driving performance increase the requirements in terms of required space. Vehicles

normally drive at a limited lateral distance, and with longitudinal space based on their reaction time. Irregular path and lowered reactions are registered after the transition. Hence, both lateral and longitudinal spatial requirements are increased. Under high-density traffic situations, the necessities can only be respected exploiting the collaboration of vehicles in the same area. Precise control of the traffic in the region of the event must be actuated.

The technological evolution comes again as support. The progress in cellular communication technology toward 5G has reduced the gap existing between the current state of the automotive scenario and a fully connected environment. Connected vehicles are seen as one of the fundamental enablers of fully automated driving vehicles, and they are becoming a reality with the latter. Vehicle connectivity will provide the possibility to exchange data, gather information, and send out indications to all entities embedded with this technology. Vehicles will be seen as powerful sensors flowing in the environment and collecting data that can be exploited by all the parties. Vehicles will move on the road regarding the influence that each action will have on all the participants. Novel control solutions will be enabled, improving the management of the traffic.

In the past, traffic control has been based on macroscopic parameters. Traffic lights varied their timing based on the density registered on the two segments forming the intersection, reduction of speed limits was based on the environmental conditions and applied homogeneously to the heterogeneous group of vehicles in the area interested. General indications were given since the capabilities in sensing, transmitting, and analyzing specific parameters such as position and speed of each vehicle were limited. Vehicular connectivity is going to overcome these boundaries. New models will address a microscopic vision of the environment, producing efficient solutions which act independently on each vehicle, always regarding the requirements of the group.

1.2 Scope of the research

The scope of this research is to provide a new solution to the issues related with vehicle transition. It will be based on the cooperation between vehicles. The solution will exploit vehicle connectivity and automated systems, relying on cellular communication and autonomous longitudinal control of vehicles. The cellular communication network will provide a centralized computational facility, and vehicles will be enabled to send information to it. In particular, vehicles will send data related to the event developing (e.g. the time buffer available for the transition and its spatial requirements) and to their physical state (their position, speed, orientation). Then, our purpose is to develop a control system that will take as input these values and will provide as output the dynamic behavior to be actuated by all vehicles in order to reach a safer disposition.

Experiments on transition show lateral irregularities on the path of the vehicle, together with unsafe behavior that may cause incidents. It has been understood that increasing the free space around the vehicle

transitioning will reduce the risk incoming by the situation. Hence, the concept rotates around the idea to allocate space for the vehicle in transition. Other vehicles will not be able to enter the reserved area until the problem is solved.

We also aim to enable a protocol that can be considered efficient. Efficiency regards the possibility to reach a safer disposition without disturbing the level of comfortability of the passengers.

An analogy with the well-known spring-mass-damper system has been adopted. Hence, vehicles will be ideally connected by spring and dampers. The acceleration resulting will be dependent on the stiffness of the spring. The stability of the protocol is based on the combination of spring constant and damper coefficient used. The distance between vehicles (hence the space freed around the vehicle in transition) will be based on the relaxation length of the springs. The analogy is pertinent because the SMD system takes into account the fundamental parameters to analyze vehicle behavior (position, orientation, speed, acceleration). Moreover, the intelligent setting of parameters will provide smooth motion. All vehicles will belong to the same physical system through SMD connections. Changing the parameters of interest, we will vary the disposition of vehicles in the road.

As said, we aim to increase the space around the vehicle transitioning. By increasing the relaxation length of the springs that connect the latter to its neighbors, a new mechanical equilibrium will be created. Hence, the controller (in analogy with a SMD system) will start to send indications to all vehicles to reach the new equilibrium.

1.3 Thesis Contribution

This thesis contributes to developing a solution to the issues arising with vehicle transition. We have designed a controller that can enlarge the free space around the vehicle transitioning to a magnitude that wholly reduces the risk for neighboring vehicles. Moreover, after the transition, the human-driven vehicle has more space available to manifest its path irregularities without impacting other objects: hence, its own safety is largely improved.

The controller's rules are based on the SMD system analogy. The SMD system involves all the parameters of interest in traffic control (position, orientation, speed, acceleration).

Methods for the parametrization of the fundamental constants of the system (relaxation length, spring constant, damping coefficient) are provided. The rules flexibly change based on the demanded operation and on time available. As a result, the system adopts motions for all vehicles that are as smooth as possible, considering the limit in time in which the operation must be completed. Furthermore, the control system constitutes a basis of traffic control mechanisms that can be adopted outside the specific case of transition, e.g. ramp entrance.

The traffic control system is constituted by a controller that is instantiated in a server. The communication between the controller and the vehicles is enabled by C-V2X technology. The system has been tested on

VEINS, coupling a traffic simulator (SUMO) and a network simulator (OMNeT++). In this way, realistic results that consider the available technology for vehicular connectivity are provided.

1.4 Thesis Outline

In chapter 2, the literature review is presented. Previous studies on transition and transition methods are shown. The inter-vehicular connection will be debated, together with existing traffic control models. Chapter 3 presents the model that will be used in the execution of our algorithm. The configuration of the fundamental parameters is shown. Chapter 4 includes simulation models, software, and setup. Simulation results are shown in chapter 5. Last, chapter 6 includes conclusions and future work.

2 Literature Review

The model studied as a reaction to vehicle transition will interest diverse areas. First, it is crucial to catch how the coexistence of human-based and autonomous control will affect the automotive environment in the future. We will show the automation levels as defined by SAE, and the roadmap of autonomous vehicle introduction. Then, the physical and psychological effects that will condition the human driver while regaining the vehicle control will be explained. It will concern current studies, experiments, and psychological research. Hence, the necessities for the driver after the transition will be motivated.

Transition is well understood as a dangerous situation that is likely to happen in the future. However, no satisfactory solution has been designed yet as a reaction to it. We believe that the limitations of previous resolutions are due to the lack of collaboration between vehicles. The model we aim to enable is based on the cooperation between vehicles. Vehicle cooperation, as far as we are concerned, will be split into two analysis. Traffic control models that aim to manage the traffic safely and efficiently will be shown. Traffic control is undergoing a total revolution with the enhancements of computational and communication technology. Vehicles will be treated considering their individual proprieties. New traffic control models consider the parameters of single vehicles, with the same traditional purposes: developing new methods to improve overall safety and traffic efficiency. Second to traffic control is the technology used in order to enable communication and cooperation between vehicles. Connected Vehicles is an engineering problem that is near to be finally solved by automakers. Two primary communication technology options have been considered by automakers for vehicular connectivity: DSRC and C-V2X. Here, we will show the positive and negative sides of both.

Finally, new traffic control solutions need more precise positioning systems. The information of interest for our model regards position, position variation, and orientation of the participating vehicles. Traditional positioning systems based either on GNSS or on cellular communication networks are not able to provide the accuracy needed. Hence, the novel solutions presented for vehicular scenarios are shown.

The literature review will be organized as follows. Chapter 2.1 will show the evolution and expectations of autonomous system for vehicles. The issues arising with a higher degree of automation will be illustrated, and the requirements of transition will be debated. Chapter 2.2 will interest the cooperation between vehicles. We will show that the cooperation between vehicles is related with modern traffic control solutions. Moreover, we will analyze the new model based on the SMD system that will be central in the execution of our algorithm. Then, we will concentrate on connected vehicles and the technological options for them, since new systems for traffic management are enabled by vehicular connectivity. Last, we will discuss the novelties brought for vehicle positioning that will have a central role to gather the data needed for cooperation.

2.1 Automation Effects on Vehicles Equipped with both Manual and Autonomous Driving Modules

Connected vehicles will dramatically speed up the evolution in automation [1], and automated vehicles of SAE level 4 are likely to be common in our roads before 2030 [2]. While this evolution will bring a large variety of solutions for existing inefficiencies, it will also create new problems related to the high level of automated controls that will be at risk of failure. The aviation industry has always been forefront when debating about automation. For this reason, it will be briefly considered.

Planes are the safest transport medium, both considering mileage traveled and hours traveled [3]. It is due in part to the professionalism of trained personal (a pilot must spend several years of training, in which he gets used also to failure and critical conditions, before having in his own hands the control of a commercial flight) and to the large utilization of automated systems. Under particular operative conditions, a plane can complete an entire flight relying on its sensors and control mechanisms, without even involving a human pilot. Automation is thought to provide precise and over the human capacity controls, and it is considered to help the pilot in the task of conducting safely the airplane. It is also understood that automation involvement has made planes far safer than in the past and, in most cases, people feel safe when the driving task is in control of the machine [4].

However, automation brings also new, less common, critical issues to be considered together with traditional human-based faults. Firstly, increasing the level of automation the pilot relies more on the accuracy of sensors and precision of control mechanism. Redundant sensors are added in order to have more data to depend on, but in the case of faulty sensor readings, the machine may become “blind” or “hallucinated”, thus endangering passengers’ life. The control given as output is dictated by the input received, inaccurate sensor readings provide wrong inputs causing erroneous control decisions. The most recent example is the Indonesian Lion Air flight 610 involving a BOEING 737 MAX. After the analysis pursued on the data of the flight after the crash, it has been understood that a defective sensor installed to control the pitch behavior of the airplane was providing wrong readings to the automated control mechanism [5]. The pilot, in the short amount of time before the crash, has not been able to disengage the control mechanism and he had approximately no control on the plane: this led to the fatal accident.

The sensor considered in the previous example was included to aid the pilot during the takeoff and landing procedure. However, under normal conditions, a trained pilot can execute the same commands without a similar control mechanism. The pilot had also the possibility to disengage the automatic control if he had realized that it was compromising vehicle dynamics. The automatic control for flight 610 is the main cause of the accident, even if it has been caused by a sensor that has silently aided pilots in a multitude of other situations [5]. Hence, the relationship between the autonomous system and the human must be considered. Referring again to the same episodes, it has been said that if the crew had realized the situation and then

took manual control of the vehicle, the plane would have had no other reason to crash. Thus, why did not the pilot do that? Which would have been the risks in suddenly taking control under stressed circumstances? Which is, finally, the right level of interaction between the human and the machine?

Automated driving brings two main key points to be analyzed for the safety of the passengers.

- The degree of reliability of the sensors and actuators in charge of autonomous driving. Moreover, it is needed to understand when the control system is inhibited or fails, in order to give back the commands to a human driver.
- The relationship that develops between human and machine when there is a transition of commands between two driving modalities.

Only one example has been debated in order to understand the issues related to automation, but in the aviation industry problems in this area are countless [6], [7]. At this point, it is essential to be clear on the fact that automation does not come in a whole without the possibility of failures and, during the evolution of automated systems, considerations on sources of issues and reaction protocols must be made. In the following, the automation levels and state of the art for the automotive industry will be analyzed. Then, the risk associated with the relationship between a highly automated machine and human pilot (that plays the role of a passenger during autonomous mode) will be specified.

2.1.1 Automation Levels for the Automotive Industry

The excursus considering the interaction with autonomous control in the aviation industry is useful to reveal the problems related to automation. The aviation branch started to work on automation several decades before the automotive industry. It becomes useful to create a parallelism between the two areas that, in practice, contain similar situations. Automated vehicles (from now on, the term “vehicle” will be used referring to “terrestrial vehicle”) are becoming a reality, and related problems are directly following it.

The Society of Automotive Engineers has defined in SAE J3016 six levels of automation based on the number of actions and attention to be addressed to the human driver and the degree of control taken directly from the vehicle (figure 2-1) [8]. This classification is commonly accepted by all the parties involved in this area. Firstly, the categorization given by SAE will be discussed. Then, short feedback on the current state of autonomous vehicles will be given, highlighting the problem we will focus on for this study.

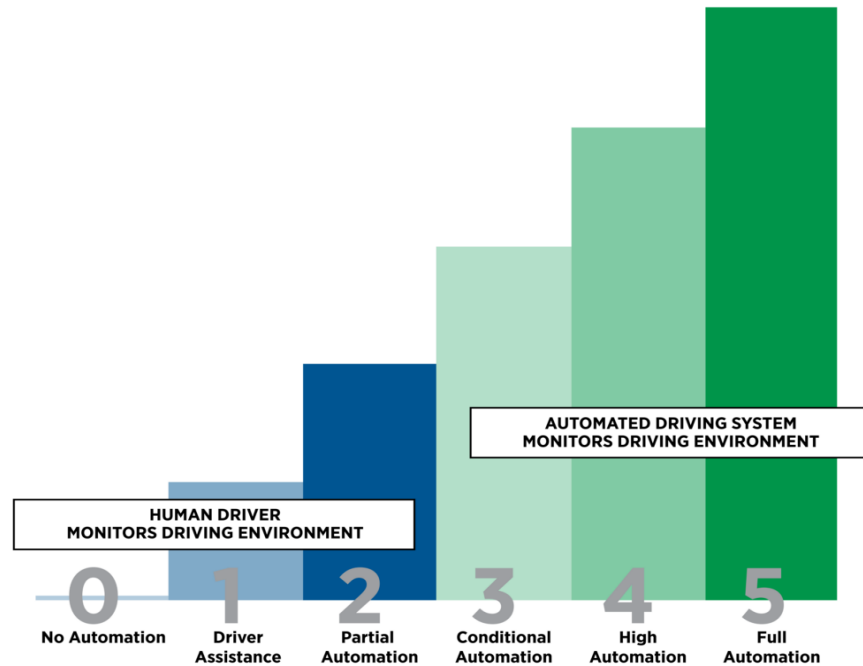

Figure 2-ISAE levels of automation [9]

Level 0: No automation

The vehicle has no automated assistance technologies. Hence, it relies on human to actuate each driving action.

Level 1: Driver assistance

The vehicle should have at least one advanced driver assistance feature to enter this category. Mobility is still supervised by a human, but the vehicle can maintain its speed under certain circumstances. Lane-keeping technology also falls into this category.

Level 2: Partial Automation

A vehicle that belongs to the second level is embedded with two or more advanced driver assistance systems (ADAS) that are able to control breaking, steering and acceleration under some circumstances. The assists features comprehend adaptive cruise control, active lane keep assist and automatic emergency breaking. The coordination between two or more of these technologies helps them in the Level 2 qualification. Importantly, the human driver must monitor constantly the vehicle's movements.

Level 3: Partial Automation

The jump in complexity between Levels 2 and 3 is enormous compared to the jump between 1 and 2. A Level 3 vehicle can take full control of driving when certain operating conditions are met.

For example, a vehicle that can manage itself the highway, excluding ramp entrance and exits, may be considered Level 3 automated. This level of automation requires advanced sensor packages, hardware backups and sophisticated software to keep occupants safe.

The driver must remain vigilant, even when the vehicle is self-driving, in the event of a failure. Even with Level 3, a driver monitor system is all but a prerequisite to ensure that the person in the driver's seat is sufficiently alerted to take over when conditions dictate.

Level 4: High Automation

A Level 4 vehicle is capable of completing an entire journey without driver intervention, even operating without a driver at all, but the vehicle does have some constraints. As an example, a Level 4 vehicle may be confined to a specific geographical area (i.e., geofenced), or it could be prohibited from operating beyond a certain speed. A Level 4 vehicle likely still maintains driver controls like a steering wheel and pedals for those instances in which a human may be required to assume control.

Level 5: Full automation

Level 5 is the ultimate goal of self-driving vehicle developers. A Level 5 vehicle is capable of complete hands-off, driverless operation under all circumstances. This is the level where there may be no provisions for human control. A vehicle's passenger would be able to, in theory, play a videogame, unconcerned about the act of driving. A Level 5 autonomous vehicle is unconstrained geographically and theoretically able to travel at all speeds in safety, thanks to advanced software and vehicle-to-vehicle (V2V) and vehicle-to-everything (V2X) communications [9].

2.1.2 Automated Vehicles: Where They Stand Now?

In the previous paragraph, a general definition of automation divided into different levels has been shown. The progress on automation in the last years has been dramatically steep, and countries are granting great economic effort to reach full automation as soon as possible [10]. However, the context of this evolution has not reached yet its saturation point, and the progress toward all the phases has been conducted gradually. Partial and conditional automation (level 2 and 3) are the state of art and vehicles of levels 2 and 3 are already present in our roads. It means that many of the vehicles moving in the terrestrial environment are already able to manage full control of themselves under specific conditions (e.g., straight freeway). Level 4 vehicles are becoming real [2], [11].

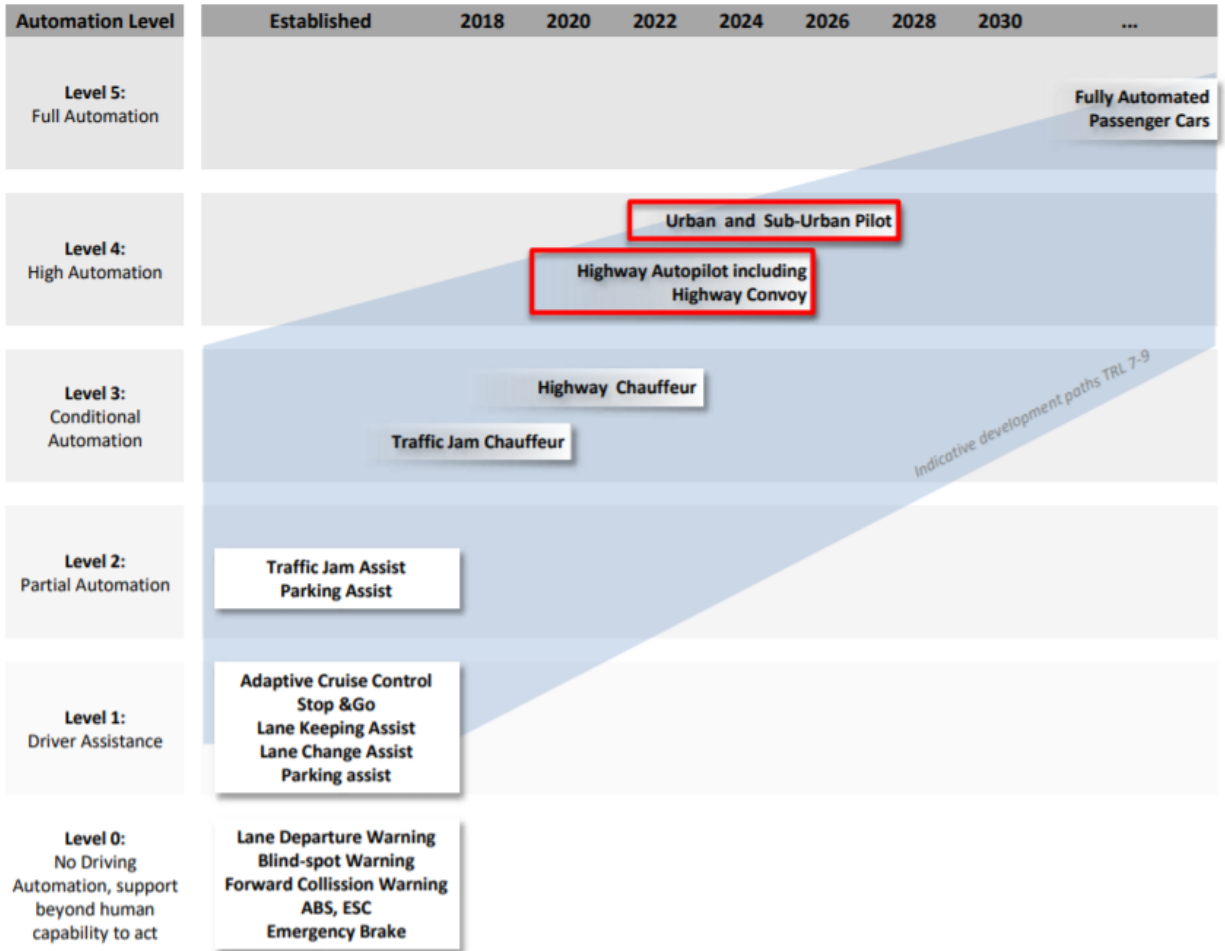

Figure 2-2 Roadmap of automated driving for passenger cars [11]

Until the recent period, the tasks managed autonomously by the vehicle were not enough for it to take full responsibility for the driving behavior. It means that the driver has always been asked to be ready to take control of the vehicle. Consequently, the driver had no opportunity to get much distracted while seated as the pilot of the car. In practice, the difference is that until now the pilot has always been asked to take responsibility for the driving protocols without relying much on sensors and actuators operated autonomously by the vehicle. However, there are numerous examples of novel vehicles able to conduct driving tasks autonomously, and figure 2-2 shows that we are entering a period in which the majority of driving operations will be addressed to the autonomous system. Relying on the knowledge acquired by the experience in the aviation industry, we understand that this evolution will bring similar problems also to the ground. The fact that a vehicle in the future may lose controlling capabilities during autonomous mode has to be taken into account. How this vehicle will react, how the driver will gain control of it and at which degree the surrounding vehicles will be involved are all valid points to be studied for future deployments.

2.1.3 Transition between Autonomous and Manual Modes

In the specific, this thesis will discuss the issue related to the handover of commands between autonomous and manual mode, and it will focus on a reaction method based on new technological introductions to make the transition as safe and efficient as possible. For this, it will be needed to study which are the logical passages to be made, and which are the technological and physical components needed to perform these functions.

Handover between driving modes is well-understood as one of the trickiest situations to be aware of in the next decades. Different studies have been pursued to testify it. These studies have been entirely led on driving simulators. In many cases, researchers have exploited advance drivers' simulator capable of reproducing forces on the body when the vehicle accelerates or steers.

Driving simulator experiments have been designed to study driver capability to gain back the controls from an automated vehicle [12]. Eye-tracking data were used to understand the attention of the driver to the surrounding. Furthermore, driver steering control and acceleration behaviors were studied in the seconds next to the disengagement. In this research, drivers were also asked to engage a secondary task in order to reflect the course of a realistic situation. The results show that at the moment in which the driver was gaining back control, irregularities in both the longitudinal and lateral direction of the vehicle appeared. While, in general, vehicles have some gap they can play with on the longitudinal axis, laterally (when adjacent lanes are present) the distance between vehicles is limited. It is understood which the first issue related to handover is: the driver gaining back the control of the vehicle is lacking sensibility with his vehicle, the lateral paths caused by the reduced performance can bring the vehicle to overcome the limits of the road or to impact neighbor cars.

Furthermore, a reduction of the longitudinal distance between two vehicles during autonomous driving will be possible (because of shorter reaction time for the machine compared to the human reflexes), increasing the overall road capacity. During a transition, it will be needed to increase the gap, simply because the human driver will not be able to react as fast as a vehicle in autonomous mode.

A study of the BMW Group Research and Technology investigates reaction time and execution behavior of drivers resuming control of the vehicle compared to a baseline study in which the vehicle was piloted in manual mode constantly [13]. It shows significant differences between the two cases. For the test, it has been asked the drivers to gain control of the vehicle because of an incident creating a hazard on the current lane. Thus, it was necessary to switch lane in order to avoid the stopped car. Results show that drivers without any automation assistance had reacted faster, gazing mirrors more and doing shoulders check. As a result, they were conducting safer maneuvers. Moreover, acceleration and steering behavior were smoother in the base-line experiment, considering the cases with the transition. The results generally

indicate the manifestations of automation effects, since they represent the degradation in driver performance when a transition from autonomous to manual occurs.

Another study led by Borowsky et al. analyzes the behavior of drivers when they are asked to execute a secondary visual task that requires them to take the eyes off the road [14]. The eye-tracking system was used to detect their gaze directions. Even if in this simulation the driving mode was always set to manual, the results are interesting, and they indicate the difficulties to keep up the situational awareness if the manual piloting is partially interrupted by the request to perform a second operation. Moving toward our specific case, during the autonomous driving, passengers are likely to lose attention toward the environment, and this can impair their capabilities once they are asked to resume control.

While it is easier to understand the danger created by the reduction of sensibility with the vehicle since small irregularities at high speed may have as consequence hazardous movements, it is less direct to understand the gravity of the loss of situation awareness to which drivers in the experiments are subjected. In the following, the degradation of performance will be analyzed from a psychological point of view. This investigation is useful to understand the causes of performance reduction and the safety necessities for the passengers.

2.1.4 The Dual Processing Paradigm

To explain how virtually our brain will interact with driving tasks and transition in the automated environment, the dual processing theory as explained by Norman and Shallice has been chosen as an example [15]. In this theory, a distinction is made between automatic human processing of information and controlled human processing of information. The most important role is played by mental structure based on the action to be executed called schemata. Schemata enable the human mind to understand situations without involving much mental computation and, in our case, it helps the driver to complete a regular drive with minimal mental effort. Understanding the dual-process theory shows the reason why a transition from autonomous driving to manual may be critical in some circumstances.

A schema is a representation of well-known actions ready to be used by the mind. For example, approaching an intersection with a red traffic light, the schema for braking when a traffic light is red will be activated and the action will be executed without much mental effort in the execution. Schemas are acquired from experience, and they organize our knowledge to make assumptions based on perceptions and react to the input from the environment in a reasonable manner with low mental effort. The computational power of our brain is very limited, and if we had to elaborate and to weight all information and possible outcome at each time step, the number of actions that we could perform would be very limited. Schemas can be coupled with each other to create high order schema that can be seen as a function that our brain runs to perform a set of actions. One of these functions may be the “driving on a motorway function”, containing

conceptualisms on how to behave (no hard accelerations, no strict turns) and what to expect from the environment (no vulnerable road users crossing the road).

This course of action is based on two assumptions. Firstly, routine actions are based on schemas. In routine situations, based on sensory information, schemas are selected or inhibited with no need for central control. This selection is indicated in figure 2-3 as Contention Scheduling. In familiar situations, all the selected schemas form a high-level schema that is used with the low computational effort needed by the driver.

On the other hand, when a non-familiar or out-of-routine situation is developing, conscious attention is needed in order to change some of the parameters activated or inhibited during routine actions. In the figure, the conscious operations are carried out by the Supervisory Attentional System (SAS).

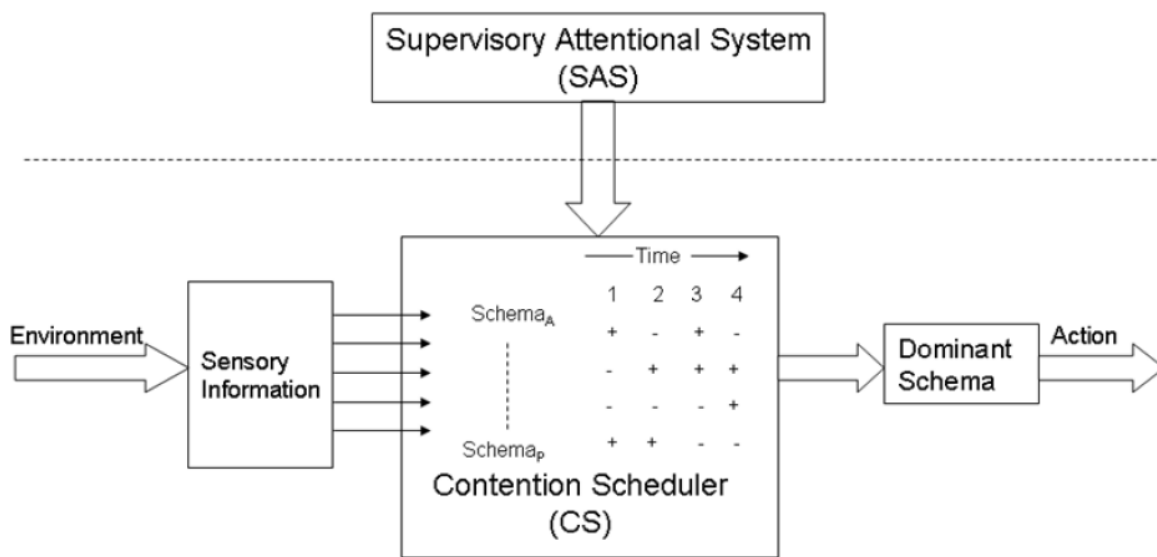

Figure 2-3 Simplified schematic representation of Norman and Shallice's model on willed and automatic control of behavior [16]

The SAS is invoked when interacting with new situations, not expected by the driver in a precise moment. It happens when a not common situation (judged not common based on the experience of the person) is developing. In these cases, deliberate decisions must be made by the person who must scan different options to choose the safest outcome. Considering the switching of command from the machine to the human, a driver trusting the autonomous system of the vehicle has with all probability deactivated the “motorway driving” schemata. When the notice indicating the need for resuming control appears on the screen, the SAS is called [16]. However, schemata activation needs time, and not all functions are ready to be used if the transition is developing suddenly. For this reason, the mental representation of the traffic situation may be incomplete, and the driver will lack in capabilities of predicting correct actions and executing commands. We can make another analogy between the working condition of our brain and the one of a computer. During the autonomous driving, the mind relaxes and deactivate all the functions for driving, because they

are no longer needed. When the transition is developing, all the functions needed to drive are reallocated but, as in the moment in which we try to open a program on our pc, the procedure takes time. This time gap in which the “driving program” is not fully operative opens a window of risk.

Autonomous driving is thought to be one of the most powerful solutions of all time to increase safety and efficiency for terrestrial vehicles. However, this feature will also bring with it a series of tricky situations that must be considered in advance in order to have a ready solution. Dual processing theories predict that the driver will not hold all the functions needed to drive a car when the vehicle is driving in automated mode. Driver performance and hazard prediction will be reduced, with consequent risks derived from the situation.

2.1.5 Effects on Drivers

Studies completed on the argument show that when it is necessary for the driver to resume control from a highly automated vehicle, his performance is impaired. When the pilot is trusting the autonomous system, he loses contact with the driving environment, and he is just not ready to resume control safely. Hence, a window of risk is created when an unexpected transition is occurring, increasing the hazards for the vehicle with handover and vehicles nearby in the area. In experimental results it is consistently seen that drivers may switch lane without considering the availability of the decided lane, they are subjected to hard acceleration and deceleration, and they have higher reaction time than other people driving the vehicle manually.

The listed conditions are more evident when the handover is sudden and not expected. However, also in the case in which the handover is announced, it is seen that the pilot needs time to gain sensibility with the vehicle and, in the moments after the transition, he shows both lateral and longitudinal irregularities [12]. Different factors must be examined deeply, such as how the trust in the system influences the transition or which is the best way to advertise the switching in the case of planned handover. Which is the rate of instability in driving after the handover and how much time the driver needs to regain full control under each situation. Few general conclusions that can help in directing further research for understating and reacting to the problem are listed here:

- The driver state (attentive or not) while in the fully autonomous mode influences the duration of the performance reduction of the driver when resuming control. It is directly correlated with the level of trust that the pilot has for the system.
- The lack of situation awareness, as explained with the dual processing theory, will condition the manual driving after the transition in a way difficult to define with precision. Under each physical, psychological or environmental condition, handover will be influenced differently [17].

- Moreover, there is no standardized protocol for the interface that will advertise the pilot to resume control. In the future, it will be needed to examine different alternatives and choose the optimal combination.

Even if the considerations above influence quantitatively the driver reaction when a transition occurs, it is seen that the qualitative behavior of the driver is identical under all circumstances. Two main consequences are derived:

- Reduction of situational awareness after resumption to manual driving. The pilot is not confident with the environment, and this can endanger himself and vehicles positioned locally nearby. The loss of situational awareness also varies the reaction time of the driver.
- The reduced driving performance of the driver due to reduced sensibility with its vehicle. The driver shows path irregularities that, combined with the high speed in motorways, may bring large fluctuations, with the risk of impacting vehicles nearby [18].

It shall be derived from these that the transition between autonomous and manual driving brings inevitable increment of the local risk. It is crucial to react proactively and to enable new mechanisms to solve this problem.

2.1.6 Solution Methods to the Issues of Vehicle Transition

Arrangements related to transition, are still an unexplored area of the automotive industry. From the past studies, it emerged the possibility to program systems that can understand when a transition is necessary, hence the pilot can be advertised with a certain margin of time. The main issue is that this type of protocol cannot foresee every type of failure. Consequently, the risk of having no time to prepare to gain control is reduced but not nulled. Moreover, the negative consequences of takeovers are related not only to the impossibility to be consciously prepared to the task by a timer but also to the impossibility to be physically sensible with the vehicle commands once regained the control.

The novelty of this project is to provide a method to generate on the road a certain degree of freedom for the vehicle. This freedom is afforded by clearing space resources around the vehicle for a certain period after handover, in order to have enough distance between vehicles to reduce the risk related to the driving irregularities that follow the transition.

Future solutions will involve new technologies introduced within the same spectrum of time of autonomous vehicles. There is no debate on any cooperative resolution for vehicle command takeover, and this thesis aims to provide a complete implementation of such methods, exploiting the evolution in communication technologies for the automotive environment.

James et al. try to provide an implementation to react to inevitable handover by understanding a time buffer relying on sensors and map data [19]. In the following, all the considerations made will exploit what depicted from the same study.

The procedure can be divided into three main steps:

- Determining whether a transition is occurring, in particular when the following operational mode is involving a larger amount of manual control from the driver;
- Determining the time buffer for continuing in the first operational mode. Time buffer here defines the interval of time between the detection of the necessity of handover and the last time step at which the vehicle will be able to pursue the first operational mode decently. This interval will be the time available for the driver to get ready in gaining the controls;
- Presenting a transition alert within the vehicle. The alert should advertise the driver of the necessity of takeover, recalling the pilot without distracting him. Moreover, if step 2 is completed successfully and a computed time buffer is accessible, the time should be shown to the driver.

For this solution, the vehicle needs to be equipped with one or more processors. “Processor” indicates any component or group of components configured to execute any process needed to analyze data and compute a solution.

Next, the vehicle needs to include a data store. “Data store” can include volatile and non-volatile memory. It is needed in order to allocate memory that is not instantaneously utilized. Hence, it is stored to be used when needed in time. The data stores should include map data. Map data includes geographical information of roads or regions in suitable forms. This map data is located almost in part on board the vehicle.

The vehicle also needs a sensor system. With sensor, it is defined any device, component and/or system that can detect, determine, assess, monitor. Sensors can work independently from each other or in combination to provide redundant and/or more precise data. In particular, a set of sensors to scan the external environment (LIDAR, RADAR and/or camera) is needed. It is important for the vehicle to understand the relative position of both static and dynamic objects in its area. The sensor system should also include sensors to quantify the absolute position of the system, together with its orientation and position variation.

Given the circumstances of the case, the vehicle must include an autonomous driving module, to fulfill SAE level 3 of automation or higher, together with a manual driving module.

When the vehicle contains these modules, a transition module can be implemented. The transition module must advertise with a certain time buffer that the vehicle is switching to an operating mode that consists of greater involvement for the human. To anticipate the transition, a model to detect the deteriorating of autonomous driving performances shall be implemented. In [19], the method used is based on the comparison between map data and external sensing. Cameras, LIDAR and RADAR sensors can build a

view of the environment around the vehicle. The captured data can be compared with the map data (of which it is assumed having a memory space allocated in the data store) to determine whether the sensed data matches the map data. A certain threshold can be defined to understand if these are substantially identical to set a confidence level.

Based on the confidence level understood from the comparison between predetermined data (map data) and sensed data (e.g., LIDAR), the time buffer can be determined. The time buffer is dependent on the confidence level: lower the confidence level, higher the differences in the comparison, lower the time buffer. It may also be dependent on the characteristics of the environment: higher complexity in the environment, lower the time buffer.

Analyzing the mismatch and environment characteristics, a precise interval for the transition can be understood. At this point, it becomes essential to advertise the pilot of the transition. In the arrangements, the transition alert can have any suitable form. The modalities taken into consideration are visual output, either with a warning signal and/or a countdown clock indicating the time buffer, aural or haptic. Any combination of these three should be taken into consideration to find the best compromise.

It has just been explained what is emerged from the literature as a method to ease the handover of controls from the machine to the human. Few considerations can be driven from it:

- The method is useful if the detection of the transition is possible and successful. Not all cases that can bring to the deteriorating of autonomous performance have been studied, and not all possible reasons are already clear to automakers. This limits the range of applicability of a system of this type, since there may be conditions in which the time buffer will not be successfully understood.
- Even in the case in which the detection is possible and successful, the method extends the time between the first transition alert and the actual transition. It gives to the pilot all the time that can be extracted from the situation, without actively increasing the interval or diminishing risks. There will be cases in which the time buffer will be large enough for the pilot to increase his situational awareness, and there will be instead situations where the time buffer available will be short and practically useless. This represents a second limit.
- Moreover, also in the case in which the detection is possible, successful and with a time buffer large enough to increase the situational awareness of the pilot, this method will not reduce risk to a minimum. In this chapter, it has been also described how an aware driver finds difficulties in regaining the sensibility with the driving task while resuming controls. Other vehicles are not advertised, in a multiple lane highway there is the possibility of other cars passing laterally next to the vehicle transitioning, and irregularities of the last vehicle can endanger cars nearby.

For all these reasons, the method presented is considered not complete and, under specific circumstances, with no utility. Where this solution is the only one available, many cases in which the risks will only

partially diminish, or even not diminish at all, will arise. The limit is to consider just an individual mechanism involving only the vehicle losing the capability of autonomous driving, a condition that makes this vehicle the most incapable of reacting. In the future, because of the rapid evolution in communication technologies and computational capabilities, new valid solutions with a centralized viewpoint and the possibility to control multiple vehicles in the traffic will be achieved. The centralization of commands will provide safer and more efficient solutions.

Control of a group of vehicles is certainly not a new concept. For example, traffic lights are a method exploited for a long time to control a group of vehicles, enhancing efficiency and safety in the automotive environment. Technological evolution has provided tools that can improve massively the degree and precision of the control that we can have on the traffic. Hence, enhanced cooperation between vehicles will be possible.

2.2 Cooperation between Vehicles

2.2.1 Traffic Control-Based Solutions

In the past, traffic control features have been adopted to make the driving condition generally safer and more efficient. Traffic control has been mainly based on macroscopic value (e.g., the density of vehicles on the two roads of an intersection) and it was providing macroscopic solutions common for a large number of vehicles (e.g., varying timing of traffic lights). The limitations were mainly given by the quantity and precision of information that could be sensed, controlled, and transmitted in the past. With the evolution of sensors, computational resources and transmission methods, the quantity and quality of data moving inside the automotive environment are exponentially improved.

The evolution in computational and communication technologies has provided to automakers the possibility to enable new solutions to traditional and future problems of the automotive environment. The problems arising from the interaction of humans and automated vehicles have already been discussed. We have focused on what happens when the commands are given back to the human after a certain period in autonomous mode. It has been detailed how the event may endanger vehicles located nearby. Cooperation between vehicles can be exploited to null the danger for the group of vehicles in the area after a transition. The current limits of cooperation are going to be overcome by novel technologies for communication and modern sensors. In this way, more precise solutions can be enabled to control the dynamic of each vehicle. Microscopic traffic simulations are already a standard tool for researchers to study the behavior of traffic under particular conditions. In the following, it will be shown how the concept of microscopic traffic model is near to the concept of microscopic traffic control and cooperative vehicles.

2.2.2 Microscopic Traffic Model for Traffic Control

Traffic problems (such as congestion, management, emission, collisions) have been widely analyzed in the last decades. In recent years, there has also been a revolution in the approach used for the analysis. Due to improvements in algorithms and software for simulations, it is possible to reproduce the behavior that vehicles keep in a real environment on computer simulations, reaching a high level of fidelity. The vehicular environment represents an intricate system and, to catch the complexity of the phenomena hiding inside of it, different traffic flow models have been developed, simulating the action/reaction mechanism of vehicles sharing the same environment.

Generally speaking, the existing traffic flow models can be divided into two main categories: macroscopic and microscopic. Macroscopic traffic flow models generalize the traffic flow as compressible fluid formed by vehicles, and they use collective variables such as density or average speed to characterize a comprehensive view of the environment [20]. This category will have no relevance for our topic, and no further information will be given on it. From the perspective of microscopic traffic models, instead, each vehicle is represented as a particle, and the vehicular traffic flow is treated with variables representing the interaction of each particle with the others. Therefore, microscopic values such as velocity, position, and acceleration are used to capture the relationships between vehicles.

The latter was used to mime the behavior of vehicles, in order to test new traffic management solutions on computer simulation relying on the efficiency of the simulator. This approach brings positive effects in terms of safety and costs (since new protocols are first tested in a simulated environment), while it is limited by the trustworthiness of the model. The similarity between microscopic traffic models and the concept of microscopic traffic control is given by the parameters that are taken into account in both cases. Speed, acceleration, position, and orientation of each vehicle are considered to model the traffic flow. A microscopic traffic controller will interact with the same values in order to redistribute the flow.

The differences are given by the fact that these models are built just to reproduce the driver reaction and not to control the vehicle behavior even if, in limited cases, they have been exploited to design controls of vehicle dynamic (e.g., to control the actuation of Adaptive Cruise Control [21]). For example, the typical car following model assumes that the motion of each car in the line of traffic depends only on that of the car in front of it. In the future, when autonomous driving will provide the possibility to analyze a higher quantity of data, with slower reaction time and with a homogeneous view of the environment in both forward and rearward directions, the utilization of models in which only the following vehicle is considered represents a limitation. For this reason, new traffic control models have been recently developed, with the main task of producing efficient management of vehicles, overcoming the limitations of models built to simulate drivers' behavior.

For traffic control and cooperation between vehicles, we need to define rules to be followed by the vehicles. One of the most valued control methods for autonomous vehicle applications is represented by the SMD control model. The SMD system has motion rules that can be adapted for vehicular applications, and it will be the basis for the controller in the role of managing the transition.

2.2.2.1 Spring-Mass-Damper System Analogy:

The strength of a SMD based traffic control model is the self-organization capability that the system provides. Under all traffic circumstances, vehicles should move inside the environment regarding safety first, then efficiency. In order to move safely and efficiently, the vehicles need to keep a particular longitudinal gap between each other. It means that they should align at a certain distance to balance road capacity, safety, and traffic efficiency. The existence of an alignment distance, at which a vehicle should neither accelerate nor decelerate to be in its best position, also means that a repulsion zone and attraction zone exist, as shown in figure 2-4. This concept can be generalized for each vehicle and creates a line for the association for the behavior of two vehicles on the same lane and two masses connected by a spring and a damper.

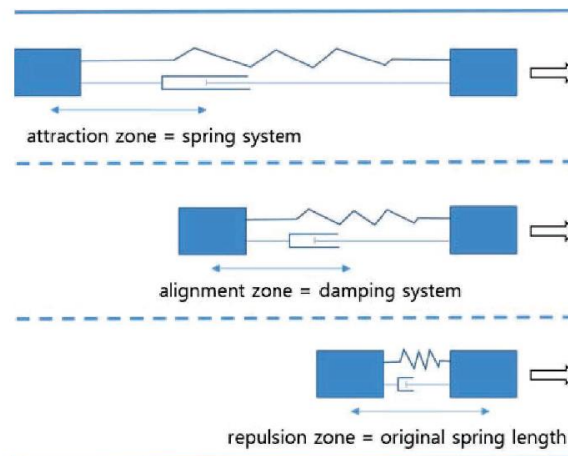

Figure 2-4 Scheme of longitudinal matching zones for vehicles [22]

In this way, exploiting the similarity of the motion for the two systems and adjusting the values for the spring and damper objects, it is possible to build a model for control that respects the requirements of the traffic flow. This analogy has been exploited by researchers to structure both microscopic traffic models and traffic control models for vehicular applications.

In [23], a SMD system integrated model for heterogeneous traffic is proposed. This model aims to overcome the limitation of previous microscopic traffic models that ignore vehicle-related aspects, while they were concentrating more on driver behavior related parameters. Given more importance to the vehicle properties, it can be seen how this evolution is relevant to the necessities of a mechanism to control vehicles in an automated environment, where the human drivers have an insignificant role. In [24], a traffic model

inspired by a mass-spring-damper-clutch system is proposed. In this study, the mechanical clutch is added to the system in order to resemble delayed actions due to the reaction time of the entity in control. Compared to the traditional car following models, the novelties introduced offer physically interpretable insights of the following behavior. Moreover, they characterize the impact of a vehicle on its leader, concept usually neglected by previous models. The fact that we can directly chain multiple vehicles in different directions makes the SMD system well suited in traffic control applications for the automated environment. Automated vehicles will no longer have the sensing limitations that characterize human driving, and building relationships with other parties at 360 degrees will undoubtedly result in more efficient and safer protocols.

A strategy to control single lane vehicle behavior is proposed in [22]. This paper relies on swarm intelligence, which describes fish schooling or bird flocking, respecting rules that are common to the entire formation. These rules, in the automotive environment, are formed to move vehicles in formation without collision, and they are expressed by spring mass damper systems. Connected and autonomous vehicles platoon formation and evolution are thus controlled by the spring constant and the damping coefficient assigned to each subsystem. In the same study, valid domains for these constants to provide realistic control and behavior, together with stability, were derived based on vehicle physical proprieties, such as acceleration/deceleration capabilities. The authors have also analyzed the possibility of using the same concept in mixed traffic, with connected and automated vehicles sharing the road with human-driven vehicles [25]. In [26], the ideas are further expanded with the consideration of cut-in movements in the platoon. In this way, the theoretical framework takes into consideration the presence of multiple lanes, from which vehicles can switch based on their necessity. Hence, the SMD control system gives also the possibility to treat multiple lane environment.

Even if the treatment reserved for the fundamental parameters is not the same for all the studies, we can derive some common considerations:

- In all the previous studies made on a SMD based traffic control system, the fundamental parameters are the relaxation length of the springs, the spring constant, and the damping coefficient;
- Regarding the relaxation length of the spring, it gives the distance at which two vehicles will be neither attracted or repulsed by each other. It means that the distance that two vehicles will keep from each other is defined by this parameter. Hence it is directly derived by the reaction time of the entity controlling the vehicle and the vehicle speed;
- The spring constant is the main factor from which the acceleration of the vehicle is derived. It is thus settled based on the desired acceleration rate, together with limits given by the acceleration/deceleration capabilities of each vehicle.

- The damping coefficient intervenes in the stability of the motion of the vehicles. If the damping coefficient is too low, the vehicles will oscillate around the equilibrium position they aim to reach. Moreover, if it is too high, the response speed of the system will be lower, and vehicles will need more time to reach the position desired.

The correct combination of the previous parameters can provide both realistic outputs for traffic simulations and efficient and stable control mechanisms. For this thesis, we are more interested in which are the controlling capabilities attributed to the model.

It is also interesting to compare the effects of various SMD controller characteristics. A framework that analyzes the efficiency and stability of different models is provided by Eyre and Yanakiev [27]. In particular, the study takes into consideration various combinations of spacing policy and coupling directionality.

Spacing Policy: Constant Spacing vs. Time Headway:

If the control mechanism is using a constant spacing technique, its purpose will be to maintain a constant distance in terms of space between itself and the following vehicle at whatever speed. On the other hand, time headway policy aims to keep the same distance in terms of time between a vehicle and its predecessor. This means that the space distance will change based on the speed at which the vehicle is going. When driving, the human pilot is suited to follow more the latter policy, adapting it to his reaction time. A comparison between the two cases is useful to define which system is more efficient.

Directionality: Unidirectionality vs. Bidirectionality:

The bidirectional control scheme is the concept that directly comes to mind when speaking of a SMD control system. It is the technical implementation coming directly from the physical model. Each mass (vehicle in our case) is considered coupled by springs and dampers to both preceding and following masses. In this way, both information coming from the follower and following vehicles are used to compute the desired output. In the unidirectional coupling scenario, instead, each body is considered connected only to the following vehicle without receiving any information about its follower. There is not a direct physical implementation of a unidirectional coupling, but it is considered useful to compare the two situations to derive a qualitative analysis of these two systems.

The results of the paper cited represent a simplified comparison of models that can be taken as hints for the qualitative choice of the controller characteristics. For example, it is shown that with constant spacing policy, under some circumstances, it is not possible to reach string stability. On the other hand, string stability is reached for both unidirectional and bidirectional controller under the condition of constant time headway. Hence, it is more convenient to follow the time headway policy. The authors also warn the reader not to take as granted all the conclusion driven in the paper, since they are tested under specific conditions

that may not represent the actual case. For these reasons, during our simulation, we have tested both bidirectional and unidirectional combination before deriving the final choice on the control method.

2.2.2.2 *Vehicle Connectivity for the Traffic Control Model*

It is important to stress the fact that enhanced communication between the parties is necessary when enabling modern control systems for the cooperation between vehicles. The main variables of the controller are decided based on the conditions of the overall flow. When the situation is interesting a group of vehicles, information exchange between them is necessary.

Furthermore, fast, reliable, and organized computation is needed to elaborate all the information. It is probable that the computational capabilities needed will be available only in fixed computational resources. Hence, a communication line between a computational facility that can host the application and all the involved vehicles becomes necessary [28]. Given the importance that cooperation between vehicles takes for the protocol, the Connected Vehicles state of art and technology will be analyzed next.

2.2.3 Technological Requirements for Cooperative Reaction: Connected Vehicles

It is not correct to affirm that cooperation between vehicles is entirely a new argument. For example, in the case of a vehicle entering the motorway from a ramp, visual communication between drivers has always been utilized during the execution of the function. The vehicle approaching the ramp position from the motorway can understand the intention of the one arriving from the ramp and it can operate in a manner that facilitates the action of the other driver. The problem is the low quality of this communication, which can often bring to misjudgments that reduce the efficiency of the operation. There is a multitude of cases in which drivers try to understand others' intentions on the road, to ease the consequent operations. Again, the problem comes from how easy it is to misunderstand this information.

It is clear that communication on the road is a key for safety and efficiency, and its limitations are given by boundaries settled by the medium used to communicate. In the future, new advantages will be provided with the introduction of new communication methods. Hence, vehicles on the road will see each other as teammates. Every action will be compared with the positiveness given to the group. In this way, we will reach under each condition the best operative state.

CVs intend to enable vehicles to exchange information with each other. Hence, a comprehensive view of the environment can be built, and new efficient solutions can be given to improve traffic situations. Moreover, the concept of connected vehicles is directly correlated with vehicle automation, since automation is strongly related to the quality of information that can be gathered regarding vehicles' state and traffic conditions [29]. In the following, a general review of the use cases and system requirements to enable CVs will be given.

The automotive industry is moving toward connected and autonomous vehicles that, as said, offer many benefits such as improved safety, less traffic congestion, lower environmental impacts. More precisely,

connected vehicle and inter-vehicular communication will bring a new set of features which will change the transportation environment completely. The safety of our road transports will reach an entirely new level, communication with road infrastructures and users (pedestrians, bicycles) will change the way we see our movements in a way difficult to analyze in advance. Ground transportation will be positively influenced by the massive amount of information that will be shared by vehicles. In particular, we are going to organize the areas involved in the following classification:

- Safety;
- Fuel consumption reduction;
- Time wasted reduction;
- Entertainment.

Safety:

Connected vehicles are providing improvements in safety applications. In the past, human drivers were not able to understand what was happening inside other vehicles. For example, we were generally not able to understand the drowsy state of another driver. Moreover, the spatial division of the road was not clearly defined. The aviation industry has a marked difference on this side: airplane routes are centrally controlled. Hence, the space needed for the airplane is reserved also based on its future positions. Ground transportation is lacking this concept. Drivers know they cannot occupy the amount of space where another vehicle is currently positioned, but they are not conscious of its future route. Last, humans are likely to get annoyed while driving, tired, physically or psychologically compromised. There is a high probability for humans of committing errors. Vehicular connectivity and automation will overcome all the limitations state above. Hence, CAV technology introduction is foreseen to play an important role in increasing vehicle safety in the future.

Fuel consumption:

Fuel consumption is one of the significant aspects that automotive companies are trying to improve in new cars [30]. The ecological requirements are every year more stringent, and buyers are always paying more attention to this aspect. The driving style has a major impact on fuel consumption. CVs will increase knowledge about the relationship between vehicle behavior and fuel efficiency. Centralized management can help in varying vehicle behavior, considering a multitude of factors that are not in the line of sight of the human driver. Hence, the engine map can be exploited more efficiently, reducing fuel consumption. Moreover, routing will be optimized with real-time solutions to reduce congestion. Hence, fuel waste will be limited.

Traffic Efficiency:

Management and control are related to the understanding of each situation, from which the most efficient output can be driven. The understanding of the situation is based on the experience and the variables that

can be sensed. Experience increases in performance when sensors can detect more data, and they can exchange this information between different data stores. Evolution in communication and computation gives a more significant number of possibilities in managing and controlling. Because of the more conscious view that managing entities will have on the environment, vehicular connectivity becomes actively part in increasing traffic efficiency.

Entertainment:

The idea that customers have of their vehicles is changed. In the past, the car was seen solely as a transport medium. Nowadays, new infotainment solutions are asked, since passengers desire new ways to enjoy their travels.

Thanks to a large amount of data exchanged, and because the vehicle will be connected to the network, even this aspect will be subjected to a revolution. All the occupants of the car will use the screen made available to them as they use their computers at home on the couch. Video streaming and online gaming are examples of novel solutions that are likely to be available [31].

NGMN has defined the requirements for enabling connected vehicle applications [32]. These requirements are defined starting from the use cases addressed. The features that the users will be able to exploit belong to a multitude of use cases in a highly heterogeneous environment. For this reason, the requirements may differ between diverse applications. In some cases, low latency and high reliability will be the focus, while there will be scenarios in which high data rate will be the only necessity. In the following, the primary necessities that interest connected vehicle applications are briefly explained.

Data rate:

The data rate is measured in bit/s at the application layer. The user experience data rate is related to the use cases considered, different applications ask for diverse conditions, and a video streaming on a vehicle consumes more data than the small and periodic messages sent to monitoring and maintenance. In vehicles with a lower degree of automation, the required data rate will be lower than 50 MB/s, while in the case of sensor information sharing between UEs supporting V2X application, and considering a high degree of automation, data rate of 1Gb/s will be necessary. 50 Mb/s will be the lower limit that is going to be available almost everywhere in the next future [33].

Latency:

Latency is not always a concern, e.g. in the use cases related to remote diagnostics and management. It becomes a fundamental KPI (key performance indicator) in safety applications and autonomous driving. For the use cases that require very low latency, end to end latency of 1 ms should be provided and, in more relaxed cases, the end to end latency should be around 10 ms [33][32].

Mobility:

Mobility is a case of interest in a vehicular environment because it refers to the propriety of the system to

provide a seamless and continuous connection when the user is moving [34]. Communication technology must be able to identify which users will need specialized mobility solutions. The requirement, in this case, is expressed in terms of the relative speed between nodes and devices at which service of quality can be delivered. In the future, the service quality should be assured up to 500 km/h [32].

Location:

In this section, we are referring both to contextual information (to deliver services ad hoc for the user) and to the importance of having much more precise location information (accuracy of 1m or less [35]) in order to evaluate the position of a vehicle. This becomes even more complicated when the device is moving at a high speed. Positioning will be deeply discussed in Chapter 2.2.7.

Security:

In the following years, the idea of security will become even more important than our current vision. An utterly connected environment will enhance our safety, but it can also be a tricky ambient if the security protocols are not sufficiently strong to defend the variety of sensitive information and applications enabled by the system. All data needs to be protected by external unauthorized access, attack, damages, and modifications. Moreover, many applications may be provided by third parties, and poorly designed applications of external partners may allow hackers to infiltrate (e. g. an edge computing platform) and then affect network functions deriving by the platform if they are not robustly segregated by each other [36].

Reliability:

Reliability is defined as the amount of packet delivered to the receiver in an amount of time predefined for the delivery of the packet, divided the total amount of sent packet. The reliability requirements are dependent on the use cases considered. In a practical situation, the communication technology should provide reliability about 99.999% for safety messages. In the case of vehicular communication, collision mitigation in an intersection is an example of an application that requires that level of reliability. In other cases, e.g. infotainment application, reliability requirement may be relaxed at 99% [32].

Connectivity Options:

When speaking of connectivity for vehicles, the main constraints come from the level of technology that is currently available. In the last years, the evolution of telecommunication technologies has made the realization of CV features accessible. The main technological alternatives that are considered in these years are DSRC and 5G C-V2X [35]. DSRC has been developed previously, and we will see that it has some limitations that are likely to be overcome by the cellular communication network. However, since DSRC is still one of the most valid alternatives to enable connected vehicle features, the next chapter will focus on it. Then, the 5G concept will be introduced.

2.2.4 DSRC

In the past years, DSRC (ITS-G5 in Europe), has been the main focus for automotive safety applications. DSRC is based on the 802.11p standard, which belongs to the 802.11 standards family. It is a short to medium range communication technology, seen as one of the most effective ways to deliver sensitive information rapidly. It supports safety applications through V2V/V2I communication.

In 1999, the U.S. Federal Communication Commission (FCC) allocated 75 MHz of bandwidth (in the 5.9 GHz region) to be exploited for V2X communication [37]. The benefits expected by FCC with the introduction of this technology were related to traveler safety, together with the reduction in traffic congestion and, as a consequence, a decrease in air pollution. It would also help to conserve remaining fossil fuel giving time to the passage to different energy sources.

DSRC operates in this region. The first two layers (MAC and PHY) of the protocol stack addressed the same scheme used by 802.11p, enhancing the proprieties of 802.11 and allowing communication V2V and V2I (vehicle to roadside unit). The MAC protocol used is CSMA (Carrier Sense Multiple Access) where each node listens to the channel, in order to understand if it is idle, before starting the transmission. Physical Layer consists of seven 10 MHz wide channels in the 5.850/5.925 GHz band. The data rate varies from 3 Mb/s to 27 Mb/s, based on the modulation scheme [38]. The latency depends on the traffic condition and the distance between antennas, but it is demonstrated to be lower than 0.2 ms in highway conditions [39]. Moreover, IEEE has released a set of standards for higher layers stack (IEEE p1609 family of Standards) to improve the aspects concerning security, privacy, and authentication, together with networking services and multi-channel operations [40]. The standards for lower and higher layers together form the whole architecture of Wireless Access in Vehicle Environments (WAVE protocol) [41].

DSRC Applications:

Table 1 DSRC use cases through V2V and V2I communication

V2I Safety	V2V Crash Avoidance Safety
Red Light Violation Warning	Emergency Electronic Brake Lights (EEBL)
Curve Speed Warning	Forward Collision Warning (FCW)
Stop Sign Gap Assist	Intersection Movement Assist (IMA)
Spot Weather Impact Warning	Left Turn Assist (LTA)
Reduced Speed/Work Zone Warning	Blind Spot/Lane change Warning (BSW/LCW)
Reduced Speed/Work Zone Warning	Do Not Pass Warning (DNPW)
Pedestrian in Signalized Crosswalk Warning	Vehicle turning Right in Front of Bus Warning

Table 1 shows the main vehicular safety applications enabled by DSRC. DSRC has been developed as a reliable source of on-road communication with low latency, both for V2V and V2I communication. Working together with intra-vehicle sensors (such as LIDAR and RADAR), DSRC can help vehicles giving a physical response to emergency situations in an interval shorter than the one commonly needed by the driver. The reaction is expressed as a change of speed and/or direction to avoid incidents, and this is the case of applications such as Emergency Electronic Brake Lights (EEBL) and Forward Collision Warning (FCW) [42]. Furthermore, vehicles are in direct communication with Road Side Unit that can gather information and analyze local data. Road Side Unit can also be in communication with infrastructure, to run applications of the type of Red Light Violation Warning and Curve Speed Warning (also considering road and weather conditions).

On the other hand, this technology has not entirely convinced automakers [43]. The road is shared not only by vehicles but also by pedestrians and other vulnerable road users. The main problem is that, except vehicles, no other road user will be connected to the same wireless source, and it makes the user itself invisible from the networking point of view [44]. DSRC is also considered as a short-range communication technology (<1000 m), and this largely limits its use cases. Even if it is a perfect choice in short-range safety applications, it cannot provide a backend connection to the network. This will also limit the performance capabilities since data analysis is made on the vehicle unit, and it is not feasible to run applications with high computational demand.

In the past, C-V2X technology has not been considered as a valid alternative for the automotive safety applications, because it could not achieve latency and reliability performances needed. Hence, DSRC was seen as the most valid solution. However, thanks to work done by telecommunication associations and standardization bodies, in the next decade we will be able to exploit the new generation of cellular communication systems, now considered a good option.

5GAA has analyzed the main performance capabilities of DSRC and C-V2X, showing how the latter outperforms the former regularly [45]. Moreover, 5G will provide a connection to the network. Exploiting the infrastructures used for traditional cellular communication, also other road users are more likely to be connected to the same network, thus increasing the variety of parties communicating with each other.

2.2.5 5G C-V2X

The 5th generation of mobile technology is structured to satisfy demands and business context starting from 2019. It is expected to be a highly flexible and scalable environment in which a fully connected society can be developed, and which gives the basis for a socio-economic transformation that will interest our lives in countless ways.

It will be needed to enhance the performance of the network in order to provide higher throughput, low latency, high reliability, increased connection density, and seamless mobility. These requirements have to

be adapted in a very heterogeneous environment, where the introduction of safety-related applications and the higher number of sensitive data exchanged will further increase the necessity of ensuring security and privacy. In order to satisfy the requirements in a cost-effective way, the network design must be organized flexibly [46].

5G will support a wide variety of emerging use cases inside and outside of the automotive industry. For the automotive environment, it will address use cases already considered with DSRC, and it will expand them enabling long-range applications.

2.2.5.1 System Performance and Design:

When we refer to system performance, we are identifying which are the capabilities needed by the system in order to meet the requirements of the huge variety of services. In the specific, connection density and traffic density shall be improved to satisfy the growth in the number of devices and data rates. The utilization efficiency of the spectrum should also be increased. Improved reliability and coverage will play a fundamental role in providing service everywhere and in case of critical environmental conditions. The KPIs are defined by NGMN and they can be found in [32].

Connection density:

The number of devices that will ask for an internet connection to fully exploit their capabilities will continuously increase. Up to several hundred thousand of simultaneously active connections per square kilometer should be considered in dense areas such as stadiums. In vehicular application, 2000 active users per square kilometer should be considered [32].

Traffic Density:

It refers to the extremely high quantity of data that the system shall be able to assist. In most critical situations, tens of vehicles will be supported in the same restricted area. Traffic density is measured as the total amount of data exchanged between users in a defined area. The requirement is thus defined as the minimum value of this factor for which the system shall be designed. For connected vehicles, up to 100 Gbps/km² will be into account.

Spectrum Efficiency:

The growth in traffic demand will bring the need for 5G technology to assess a much higher efficiency in the usage of the spectrum resources. With the actual situation, the number of cells to be added in order to satisfy the new requirements will be not reasonable. The demand for higher speed data transmission continues to increase beyond the limits of the fourth generation (4G) mobile technology. In order to sustain the future market requests, also a large amount of spectrum in the mmWave bands shall be exploited to increase communication capacity. It comes within progress in the radio access technology [47].

Coverage:

The 5G system should be able to give access to the network even in rural areas. Service must be provided

in a cost-efficient way, without increase critically the number of sites of the current grid. In the view of autonomous vehicles, this aspect is fundamental. The connection should always be available for critical use cases [48].

Resilience and high availability:

Resilience and high availability will be essential to provide minimal service in case of e.g. environmental disaster. The strength of the system will bring the 5G system to be the most used transmission method in public safety-related communications.

Resilience also refers to the capacity of the network to recover its functionalities after a failure. Hence, it is crucial to provide high availability in critical conditions. Reliability is conditioned by the capacity of the system to self-heal in the failure zones.

Architecture Design and Technological enablers:

When the baseline 4G system is compared against the 5G requirements, improvements are needed to extend network capacity, sustainability and flexibility. The traditional network cannot satisfy the large amount of information that is expected to be exchanged in the future, and essential improvements on the hardware and software components of the network, together with a variation on the architectural design, are necessary.

Softwarization will reduce at a minimum the quantity of dedicated hardware inside the network, in order to enhance the programmability and flexibility of the system. Higher flexibility will provide the system with the possibility to adapt to each scenario, with positive outcomes for the efficiency of the system. Self-organization and self-healing protocols are more likely to be developed in a flexible system.

The reduction of the dedicated hardware components also eases the adaptability to the requirements of different applications. The variation of settings and functions in each segment of the network will provide different virtual networks tailored to the specific use case. Hence, different *slices* will be created.

Moreover, computing facilities will be positioned all over the network, comprising its edges, in order to elaborate data logically and physically closer to the end-user, reducing latency. In the following, we will briefly explain the design principles that hold great importance for the 5G network and CV technology.

Network Softwarization:

Network softwarization is an overall transformation trend about designing, implementing, deploying, managing, and maintaining network equipment and/or network components through software programming. Network Function Virtualization (NFV) and Software-Defined Networking (SDN) are two tools of network softwarization. SDN enables fast innovation by increasing network programmability. It also leads to more excellent responsiveness, security, efficiency, and cost-effectiveness [49]. NFV replaces equipment, such as load balancers, firewalls, intrusion detection systems, and signaling systems, with software running on commodity hardware. The cost and complexity of operating the network are reduced dramatically by management software that operates on converged SDN and cloud infrastructure [50].

Network Slicing:

The evolution of the mobile network is pursued to satisfy the user requirements and to provide service to the larger number of business models that will need a communication network. With 5G heterogeneous services will coexist together with the same network architecture through Network Slicing [51].

Network slicing is a type of virtual networking architecture belonging to the same family as software-defined networking (SDN) and network functions virtualization (NFV). SDN and NFV allow better network flexibility through the partitioning of network architectures into virtual elements. In essence, network slicing allows the creation of multiple virtual networks over a shared physical infrastructure. A slice will comprehend a collection of Network Functions and a specified group of RAT settings related to each other in the best way to satisfy the needs of a particular vertical market or business model. It will condition all the components of the system, from different configurations of devices to the variation of radio access and core network settings.

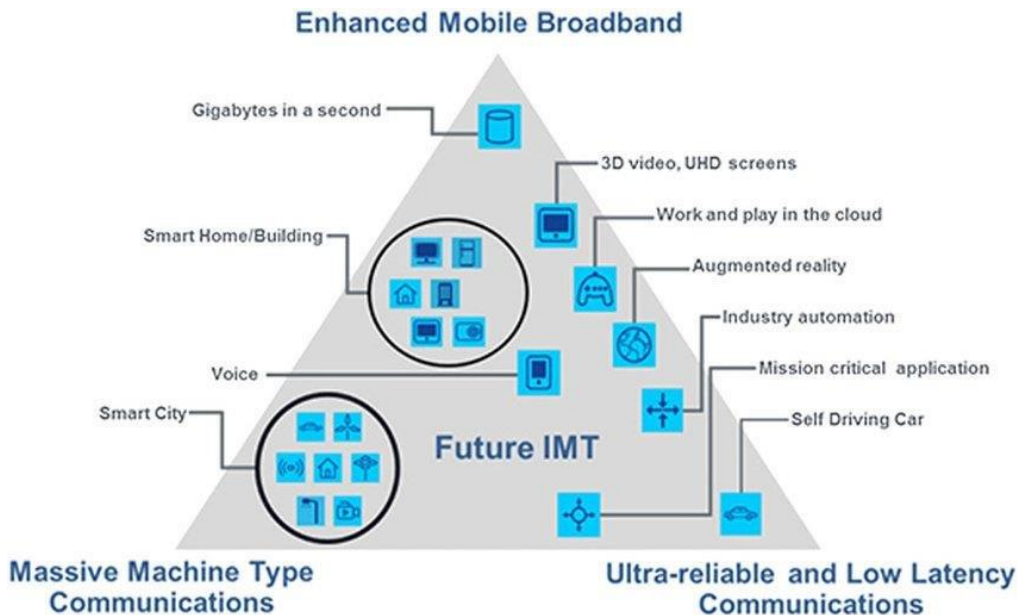

Figure 2-5 Usage Scenario of 2020 and beyond [52]

The purpose of the slice will be to provide transport and management of the type needed by the specific application, not considering all the unnecessary functionalities. Within its domain, a slice shall also respect different requirements needed for the operational efficiency of the system, such as configuration and differentiation of traffic per slice. Network slicing is considered an essential requirement for the next generation mobile system [35][53][54]. High diversity will be collected inside the same system, and the network architecture will be changed flexibly with the support of network slicing. Three primary slices are currently addressed for the automotive vertical [55]:

- Enhanced Mobile BroadBand (eMMB): it supports seamless connection with peak data rates higher than the ones given by 4G. An example of vehicular application may be HD video streaming.
- Massive Machine Type Communication (mMTC): it supports a massive number of devices sporadically active, and that use small data payloads during their period of activity. Vehicles may send diagnostic information to centralized servers that can analyze them. In this case, low data rate and low constraints for latency and reliability are considered. Given the large period of activity of a vehicle, power efficiency may be a major purpose.
- Ultra-Reliable Low Latency Communication (URLLC): it supports transmissions with the necessity of low latency and high reliability from a small number of terminals that are active during particular situations, or for a specified set of actions. Safety applications generally belong to this slice.

Integrated Computation

Computing facilities will be present all over the network in order to elaborate data logically and physically closer to end-user, reducing latency. Edge computing is a general term for a cloud-based service located at the edge of a network. Multi-access Edge Computing (MEC) is the edge computing's standard architecture created by the European Telecommunications Standards Institute's (ETSI's) MEC group [56]. MEC is based on NFV, it uses a virtualized platform to run applications at the mobile network edge. Instead of physically positioning hardware function in the cell, MEC leverages on softwarization concepts to enable the call of software-based functions on general-purpose hardware. Virtualized functions will gain importance over fixed physical hardware, bringing inside the network efficient utilization of elements, scaling down resources and simplifying management, thus bringing efficiency in energy consumption and operational sustainability [36]. The purpose of edge computing is to give real-time, high-bandwidth access to latency-critical applications, positioned at the network edge. Since edge computing is closer to the end-user and apps, it allows for a new class of cloud-native applications, and allows network operators to open their networks to a new ecosystem and value chain. In the automotive environment, real-time communication and computation have fundamental importance and with MEC we will have powerful units near to the user.

The previous features will be exploited by 5G network to enable CV technology. The spectrum of applications enabled for vehicles will have various requirements. Networks Slicing is thought to provide service under different conditions in an efficient way. Moreover, use cases that need low latency and have high computational demand will be instantiated on an edge computing resource. Softwarization is at the base of both Network Slicing and MEC. For this thesis, a detailed description of all new features introduced for the 5G network is not necessary. It is essential to understand the functions of the novel design principles introduced with 5G, and which are the operation modes and consequent use cases enabled by the two

alternatives. We have previously mentioned DSRC V2V/V2I communication modalities. Now we will briefly discuss the communication modes provided for Connected Vehicles by C-V2X.

2.2.5.2 C-V2X Operation Modes:

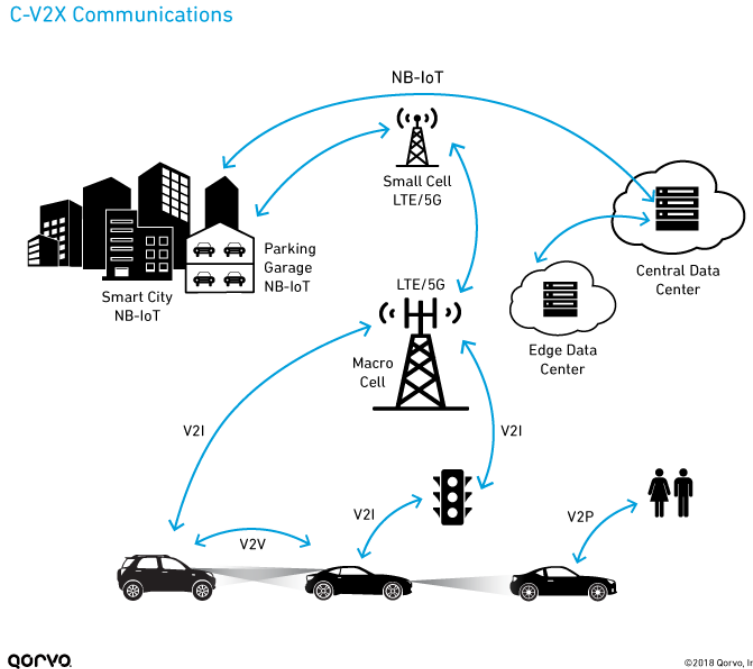

Figure 2-6 C-V2X communication modes

The operational scheme of the cellular communication network is shown in figure 2-6. It represents the vision of a fully connected environment. The cellular network will enable vehicle communication between each other and at the same time with the network, infrastructure or vulnerable road users (e.g. pedestrian). The entities will be able to use a direct link for communication, or to exploit the network. Modern cities will be embedded with sensors gathering useful information that can be transmitted to the vehicles. The computational facilities in the edge and core network will be available to analyze the information. The operational communication modes used by C-V2X are the sidelink and uplink/downlink interface. In the following, a more detailed description of the operational modes will be provided.

Direct Communication Operating Scenarios (PC5 Interface):

For years DSRC had been considered as the first option for connected vehicle services since it was built to provide direct communication between vehicles. Before 5G, the requirements needed for safety applications could not be achieved through cellular communication. DSRC, instead, enabling direct communication, had shown the capability to provide service for this type of application. Hence it was seen as the first choice despite its weak points. Consequently, the new generation cellular communication network has introduced

a sidelink interface, enabling direct communication between vehicles with different modes of operation (figure 2-7).

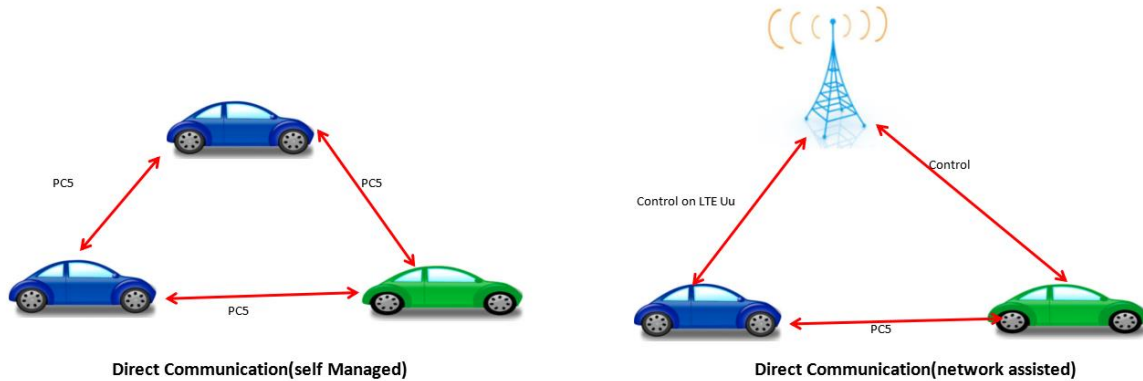

Figure 2-7 Sidelink operations mode 3 (network assisted) and mode 4 (self-managed) [57]

V2V/V2I/V2P communication can be carried on the sidelink PC5 interface with the help of the network allocating resources for the communication (network assisted) and without any control from the network (self-managed). These respectively refer to mode 3 and mode 4 of communication as defined by 3GPP [35]. Mode 4 has been introduced in order to communicate even in the worst-case scenario (absence of network coverage). This is useful given the importance of running safety application under all circumstances. Moreover, the sidelink PC5 interface can be used to offload the network.

Network Communication Operating Scenarios (Uu Interface):

The main strength of 5G C-V2X is the harmonization within one technology stack of functionalities for direct communication and cellular connectivity based on V2N communication. The Uu interface transmits a message to the network in uplink and the network transmits it to the destination over the downlink channel. It provides service for long-range applications and generally increases the spectrum of applicability for CVs [58]. Moreover, computational resources will be implemented all over the network. There will be applications that need a large number of computational resources. In these cases, the data unit of a traditional vehicle may not be able to run the application as fast as needed. Instead, the fast response will be achieved by relying on computing resources in the network. In particular, when latency becomes critical for a specific application, MEC resources will be exploited [59].

2.2.5.3 Advantages of C-V2X:

There are a series of technical and functional reasons why C-V2X may be considered better than DSRC. First, the technical performance of 5G V2X is better than the one registered with DSRC. Several companies and organizations provided simulation results considering DSRC and the sidelink interface PC5 [60] [44] [35]. These simulations have been made in both urban and freeway environment and demonstrate the

superiority of C-V2X mode 3 and mode 4 over DSRC. The communication range is increased, and it provides evident positive effects on safety since the driver gets a higher chance to be informed in time.

Focusing on the results in the high-density scenario (urban environment), the higher performance of 5G C-V2X over DSRC under the same density of vehicles also shows that C-V2X is more scalable than DSRC [35]. In fact, the spectrum for vehicular communications can be more efficiently utilized. It means that in a specific area, a higher amount of vehicular communication links can be supported with acceptable reliability.

Long-range applications will be enabled with C-V2X through the Uu interface. Moreover, MEC facilities will analyze data near the end-user. Hence, applications that require a large amount of computation will be run, providing results almost real-time.

Furthermore, one of the significant strengths of the cellular communication network over DSRC is the possibility to have an uplink/downlink connection through the Uu interface. The Uu and PC5 interface can cooperate and can be alternatively used as functionally redundant communication channels. Hence, different spectrum/frequencies, protocols, and hardware components can be used to bring redundancy into the system, increasing reliability. The duplications of messages into relatively independent channels will reliably support critical safety use cases [35], [61].

2.2.6 The Debate between DSRC and 5G C-V2X

The debate between the two options (DSRC and 5G V2X) is still open as this paper has been written. In spring 2018, Toyota announced its intention to deploy DSRC across its North American lineup from 2021, in hopes of enticing the rest of the industry to follow. It did not happen. At CES 2019, Ford announced it would deploy C-V2X from 2022. With no other automaker committing to DSRC, Toyota recently announced that it would suspend its deployment plans. Currently, it appears unlikely that there will be any further DSRC adoption in North America unless mandated by NHTSA [62].

China, which represents the world's largest market, is moving toward C-V2X adoption [63]. In Europe, despite support for C-V2X from Audi, Ford and PSA among others, the European Parliament had recently passed in April 2019 regulation that would mandate ITS-G5 on new vehicles beginning in the early 2020s. This would have made the European Union the only region with a regulation mandating V2X communications based on 802.11p [64]. However, in July 2019 The European Union has rejected the European Commission's recommendation that ITS-G5 standard shall be mandated as the requirement for V2X capabilities, in a recommendation that did not make any room for the Cellular-V2X (C-V2X) technology. This has opened the door for C-V2X, but it is important to note that this win is not equivalent to the EU mandating C-V2X. Given the number of times this decision has switched back and forth, the end of the process has not been reached yet [64].

The importance of having a fast and reliable technology for communication has been highlighted. New solutions for traffic safety and efficiency can thus be enabled exploiting CVs. CVs have been a focus for automakers in the last two decades and finally we own technological resources strong enough to make this wish a reality. Cellular communication has not been considered for vehicular solutions in the past, while DSRC was seen as the most logical choice. With the evolution toward 5G, this scenario has changed. Higher performance, lower costs, and a larger number on functionalities (due to a stable connection to the network) make 5G the most promising solution in the years to come for vehicular connectivity. In particular, V2N communication, which is only provided by cellular communication, will be used for long-range applications, to increase the reliability of the system and to give access to computational resources more powerful than the unit available on a vehicle. V2N communication will constitute the main communication mode that we will use for a cooperative reaction to transition. Hence, we will entrust to have C-V2X technology available in order to enable the process.

2.2.7 Technological Requirements for Cooperative Reaction: Positioning Systems

It has been said that vehicles will be seen as powerful sensors receiving and transmitting information about each parameter that will be considered of interest. We have also debated which will be the technological alternatives that vehicles will exploit to exchange their knowledge. Now, we need to step back and analyze which are the technologies utilized to gather information. For what regards the vehicular environment and, in the specific, for this thesis, the main variables of interest are relative to the position, position variation and acceleration. If the sensing precision would be not good enough the vehicle will transmit inaccurate information, creating confusion and erroneous reactions. It is thus important to analyze if novel technologies can provide the level of accuracy for positioning that is needed for future use cases. the standard value considered acceptable for positioning in vehicular applications is around 1 m [65]. Speed and acceleration can be either derived from the variation of position in time or directly extrapolated from the vehicle onboard units. In the following, different technologies that can be used to provide such precision are discussed.

2.2.7.1 *Global Navigation Satellite System:*

The Global Navigation Satellite System (GNSS) exploits satellites to retrieve the position and time of a specific device embedded with an antenna capable of receiving its signal. GNSS positioning starts with the simple mathematical formula $s = vt$. Once known the propagation speed of a wave, the departure and the arrival times, it is hence possible to retrieve the distance of the object. Then, satellite signals propagate uniformly in all directions. For this reason, only one satellite can help to detect the position of the object on a sphere. The univocal solution can be reached by applying the same procedure with four satellites (figure 2-8).

The first GNSS system was GPS, active in the 70s only for military service and then activated also for civilians in 1983 [66]. After GPS, other systems of this typology were introduced or are toward completion in these years (GLONASS, BeiDou, Galileo, IRNSS, QZSS).

As said, the concept is simple. The practical implementation instead discovered several issues. First, to understand the time spent from the wave to propagate, it is necessary to constantly have an absolute reference of time. The precision of the clock of a satellite must overcome the standards of traditional clocks. Accuracy is required because radio waves travel at the speed of light.

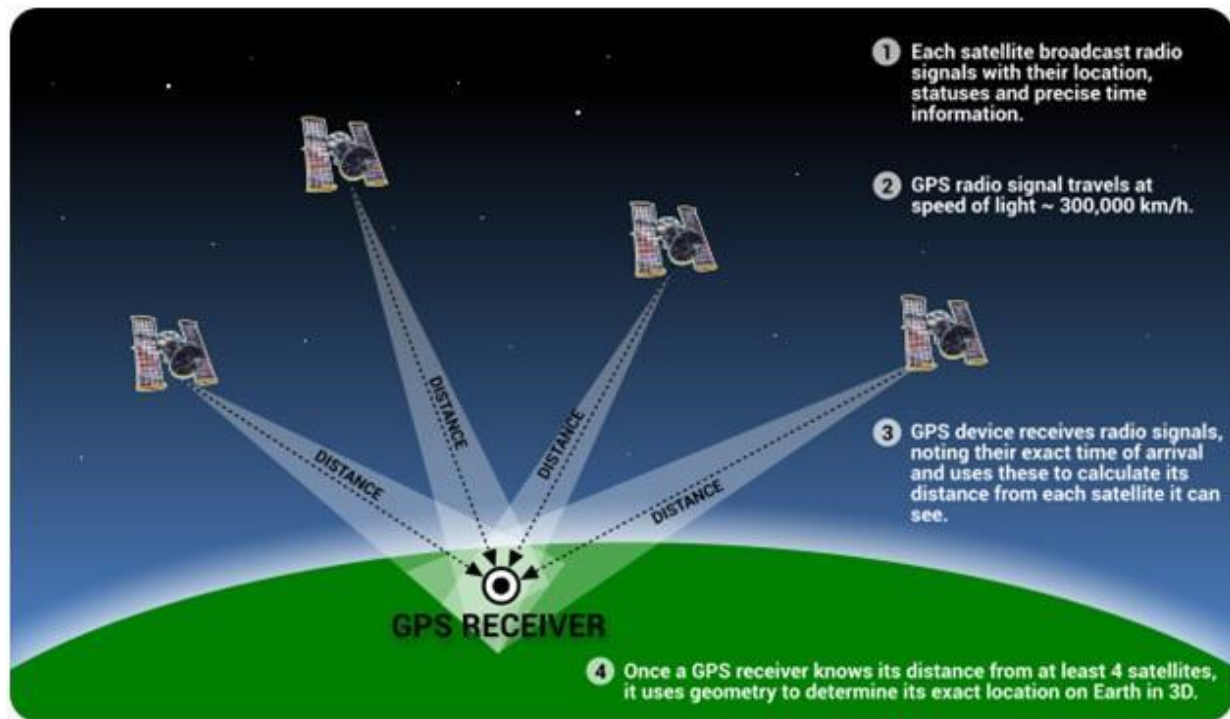

Figure 2-8 How GPS works [67]

This means that in one microsecond light travels 300 m. If the accuracy of time is over one microsecond, the indecision of the results becomes higher than 300 m. Fortunately, the latest generation of GPS satellites uses rubidium clocks that are accurate to within ± 5 parts in 10^{11} , limiting the errors under this point of view of about ± 2 meters [66]. Other sources of errors come from the precision of the orbit of the satellites, by the delays produced in the ionosphere/troposphere and by multipath caused by reflections. The GNSS system errors are grouped in table 2.

Table 2 GNSS Error Sources [66]

Contributing Source	Error Range
Satellite Clocks	± 2 m
Orbit errors	± 2.5 m
Ionospheric Delays	± 5 m
Tropospheric Delays	± 0.5 m
Receiver Noise	± 0.3 m
Multipath	± 1 m

Summing all the imprecisions, the final error for the traditional GNSS system becomes of the order of 10-20 m. While this level of accuracy may be successfully exploited under many circumstances and use cases (e.g. map position retrieval for pedestrians), it is also impossible to build unmanned or autonomous vehicle safety applications relying on it.

However, starting from its introduction and unceasingly continuing until now, modern methods to reduce these errors have been introduced. Galileo, which is planned to reach full operational condition sometime after 2020, will deliver real-time positioning accuracy down to the meter range, previously not achievable by a publicly available service [68]. New techniques such as Real-Time Kinematic may also be exploited together with GNSS reaching centimeter-level positioning [69].

Algorithms capable of compensating errors caused by clock imperfection and wave travel delay are already state of the art and continuously improving, promising a level of accuracy under the meter as standard for the next years [70].

However, GNSS fails to work under certain conditions that are common in the automotive environment. Dense urban deployments experience difficulties because of the ease of signal blocking that reduces the availability of satellite signals. In order to solve this issue, GNSS systems may work tightly coupled with other technologies, such as cellular network positioning or on-board sensor detections.

2.2.7.2 Cellular-Based Positioning:

Cellular signals are particularly attractive for navigation because of their abundance, large bandwidth and high received power [71]. Due to the blockage of the satellites and severe multipath effects, the global navigation satellite system is not always able to provide seamless signals, substantially decreasing its performance. To optimize the quality of information, it has been proposed to exploit additional information from communication systems [72], [73]. Combining data from different sources, performances can be improved because of the completion of information from one side when the other is not performing.

Cellular positioning has been utilized for decades in applications in which accuracy is less important. It relies on existing infrastructures. Thus, it does not need dedicated deployments or maintenance cost. 2G communication provided cell-ID-based positioning, giving an accuracy of the order of 100 m. In 3G, using time-difference of arrival measurements, the accuracy has been increased to 10 m [71]. Cellular positioning is used to find the position of a mobile station using location sensitive parameters. These parameters relate to the signal strength and time difference of arrival. For example, the received signal strength from a mobile station can be monitored by multiple cells, applying the propagation model of the signal to the sensed ones, the distance of the mobile station from the base stations can be determined. Once the distance from different BSs is known, the position of the mobile equipment can be acquired.

However, none of the previous cellular generations can meet the requirements needed for autonomous driving and, in particular, for the application developed in this thesis. In the following, we will draw a high-level overview of positioning exploiting 5G features, providing positioning services with accuracy beyond traditional GNSS with limited additional cost, with negligible overhead to the communication in terms of time-frequency-resources [71].

2.2.7.3 5G MmWave:

The specific signal characteristic of MmWave turns out to be particularly attractive when speaking about vehicle positioning. 5G can work coupled with other vehicle positioning systems and map data to provide the redundancy needed for certain applications, increasing the performance. 5G will present a series of proprieties that are suitable for providing accurate position: high carrier frequency, large bandwidth, network densification, and large antenna arrays [71].

High carrier frequency:

At higher frequencies (30 GHz and above, the millimeter-wave band), path loss becomes larger. High penetration loss and diffraction loss lead propagation to be dominated by the line of sight component and few reflected paths. For these reasons, the channel is composed of a few dominant components, and it becomes highly dependent on the position and orientation of the transmitter and receiver. Hence, it will become easier to track individual components, and their strong dependence on position will increase the accuracy. In other words, the radio channel and the propagation environment are tightly coupled when using millimeter waves. The relation can be exploited for positioning purposes.

Large Bandwidth:

A large amount of unused spectrum over the 30 GHz will create the possibility to use much larger bandwidth. The effect of larger bandwidth is to reduce latency due to shorter symbol times, hence increasing the accuracy of the time-based measurement. Moreover, large bandwidth brings a fast response to position changing and, because of the possibility to compute more data at the base station instead than in the cloud, rapid resolution for latency-critical application will be possible.

Network densification:

High path loss of higher frequencies will decrease the dimension of cells, hence increasing their density all over the network. In dense networks, a device has the possibility of being connected to multiple nodes. This provides backup information from a higher number of sources, and the accuracy in positioning will be increased. Dense networks provide diversity and redundancy, together with a higher probability for the mobile equipment of being always in the line of sight. For these reasons, network densification will also help in support of positioning for vehicular applications.

Thanks to all these characteristics, 5G presents a strong relationship between communication and positioning. Accurate positioning in the autonomous vehicle scenario will rely on a combination of different techniques such as satellite systems, cellular positioning, and onboard sensing.

2.2.7.4 On-Board Sensors for Positioning:

For an autonomous vehicle it is important to scan the environment in which it is moving. As the human cannot drive blindfolded, the vehicle is not able to pilot itself without the correct functioning of its sensors. Modern vehicles are already equipped with numerous sensors capable of gathering information from the external environment, providing an insight to the brain of the car. Each type of sensor has its strengths and weaknesses in terms of range and detection capabilities. Given the importance of the operation, redundancy is needed [74]. Bringing together different readings of these sensors the vehicle can understand where it is positioned in relation to other objects and can find its way on the road. In particular, all vehicles will have both active sensors, sending out energy as waves and waiting for the reflection components (e.g. radar and LIDAR) and passive sensors, simply taking information from the environment without emitting waves. The combination of all the data sensed, together with high definition maps, GNSS and the possibility to rapidly exchange all the information thanks to the communication line provided in the future will make possible accuracy and redundancy (increasing reliability) for future use cases. Accurate observations can be used by control mechanisms.

It has been previously said that, in order to react to the transition between autonomous and manual modes exploiting cooperative vehicle features, the position and speed of all vehicles involved must be known with a high level of accuracy. It has also been pointed out that until the past years, no positioning method (including GNSS or cellular-based) could provide such accuracy. Thanks to the evolution of cellular communication technology and better implementations of satellite-based options, we will be able to obtain an accuracy easily lower than 0.5 m [66]. It is in line with the needs of the application that we want to develop and for this reason, during the simulation, it will be assumed the possibility to retrieve positions of vehicles with this grade of precision.

3 Model

In the literature review, various arguments have been introduced. We have acknowledged the risks incoming from vehicle transition. Next, we have talked about novel traffic control models, that can be exploited to enable cooperation between vehicles. Cooperative vehicles are seen as a valid alternative to react to vehicle transitioning. However, cooperation is enabled only by information exchange; hence, we must rely on existing communication technologies and their performance when designing the control system. Last, we understood that the required information concerns the position and its derivatives. Again, we depend on the degree of accuracy that is provided by current positioning systems. A deep understanding of all these phases is required to design a realistic model. In the following, the protocol planned for this thesis will be analyzed.

The method presented is thought to give an alternative option to react to vehicle handover. It will exploit the novelties studied for vehicle communication and basic automated controls. No method exploiting CAVs has been taken into consideration until now. Previous methods still look into vehicle transitioning as a problem that the vehicle as to resolve on its own. We propose to improve the resolution of the event with the cooperation of a group of vehicles. The boundaries for information exchange on the road have been drastically expanded with the developing of C-V2X technology. We are now ready to create new control mechanisms, and the proposed model for traffic control aims to be part of the group.

3.1 Model Workflow

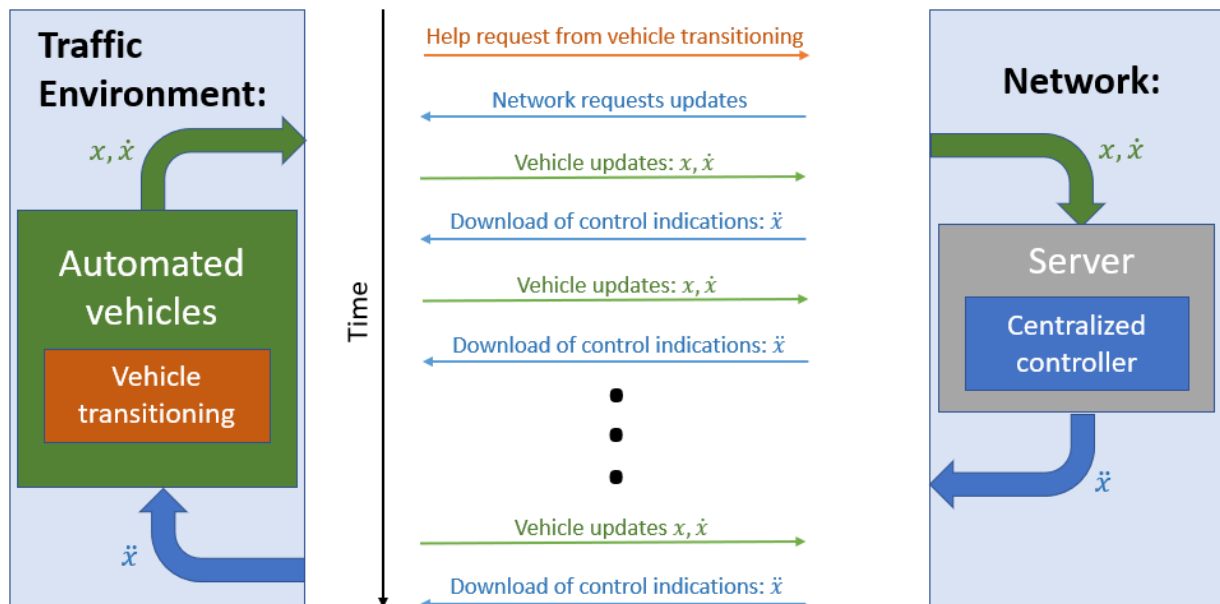

Figure 3-1 Model logical workflow

The model here explained is based on the cooperation between vehicles and cellular network. The functional workflow is shown in Figure 3-1. We see that the entities playing a role in the process are positioned either in the traffic environment or in the network. More precisely, the traffic environment is formed by a penetration rate of autonomous vehicles of 100%. Moreover, the vehicle transitioning is present. The latter is thought to drive autonomously until the end of its transition; then, the control will be in the hands of the pilot. The right side of the model comprehends the network. The component of interest of the network will be a Server. Inside the Server, the application acting as a centralized controller for the vehicles will be instantiated.

The first passage of the process is dictated by the vehicle in transition. The vehicle transitioning will understand, e.g. by comparison of data incoming from its sensors and stored map, that a transition is developing. It is assumed that it will also be capable of understanding a specific duration for the transition, indicated in the following as time buffer. Once the handover is detected, a request for help will be sent to the network. The Network will analyze the request in the Server; then the Centralized Controller will be instantiated. It is likely that the Server will not be conscious of the position of all vehicles inside the simulation. However, the dynamic state of vehicles on the road is needed as input for the Centralized Controller. The second passage is thus executed by the Server, which will send a request to all vehicles to update their position and speed continuously. Once the first set of inputs is received by the Centralized Controller, the first analysis for the outputs will be done. The procedure will be continuously repeated: vehicles will unceasingly send their values to the Server, and the Centralized Controller will update the inputs, it will recalculate the outputs, and it will send them to each vehicle, as shown in figure 3-1. We have seen what is happening to inputs and outputs. Hence, all the procedure outside of the Centralized controller is understood. Next, we will analyze what is developing inside the Centralized Controller box.

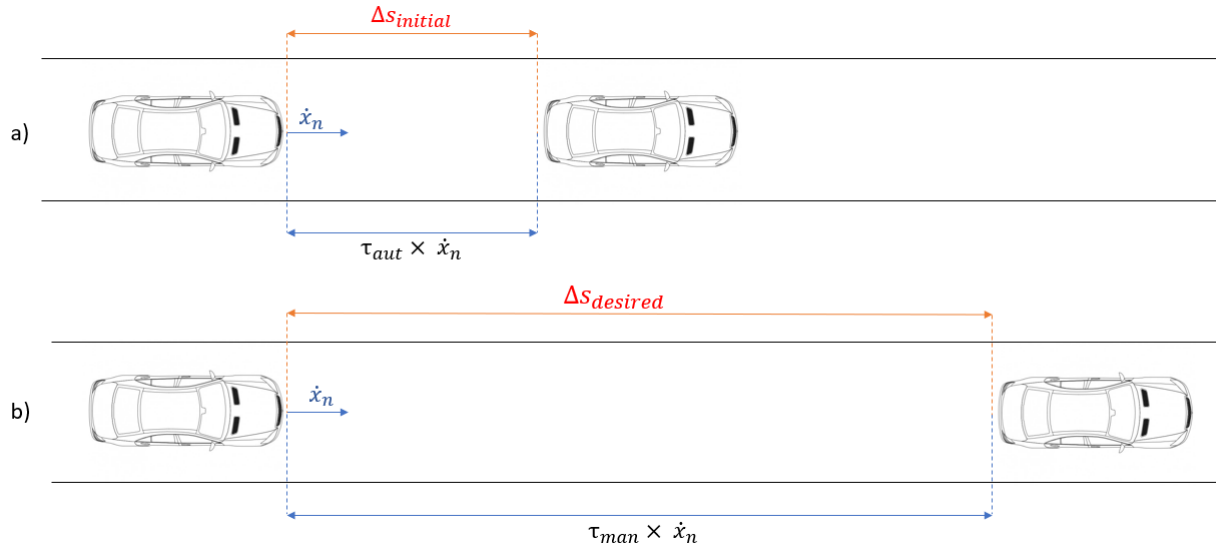

Figure 3-2 Longitudinal distance between automated a) and human-driven b) vehicles

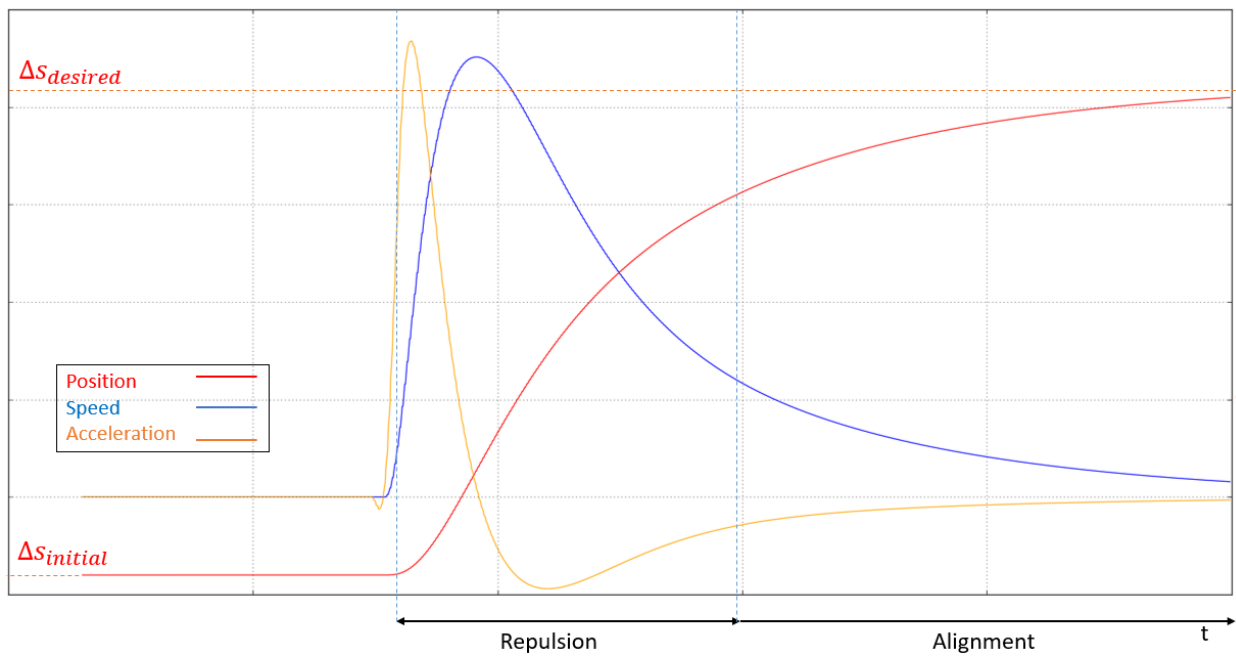

Figure 3-3 Space/Speed/Acceleration evolution vs. time, following spring-damper system motion

The purpose of the Centralized Controller is to satisfy the necessities of each vehicle in the area controlled. Let us start with a simplified analysis. Figure 3-2 shows the different requirements in terms of space of an automated and a human-driven vehicle. Assuming constant speed \dot{x}_n , the longitudinal space needed is dependent on the reaction time τ . Being the reaction time of the human larger than the one of the machines, also the space needed by a human-driven vehicle is higher. Before the transition, the vehicle will drive at a distance related to the machine reaction time. After, the human pilot will be driving, and the longitudinal

space needed will be enlarged accordingly. This is an example of the requirements that the Centralized Controller may be needed to satisfy. Moreover, knowing the time buffer for the transition, the controller is also conscious of the rapidity needed to complete the operations.

When the purpose is to increase the distance between two vehicles, the qualitative behavior desired for the motion is the one represented in figure 3-3. The absolute value of the acceleration and speed of a vehicle are represented, together with the relative distance. The relative position refers to the difference between the absolute positions of two vehicles in the same lane. The initial state may be considered the one in figure 3-2 a), the final state instead 3-2 b). Hence, we want to increase the distance from $\Delta s_{initial}$ to $\Delta s_{desired}$. The desired behavior can be divided into a repulsion zone and an alignment zone. In the former, relatively high acceleration is needed in order to increase the speed and consequently the gain in terms of space. The repulsion timing must be synchronized with the time buffer available for the transition. Once the majority of space is cleared, we want to approach the desired position smoothly and without oscillation. Hence, an alignment zone is present, where all the values for distance, position, and speed will converge efficiently. This type of behavior can be assimilated with the same of two bodies connected by a spring-damper system. The SMD system provides a repulsion zone (or attraction in the case of two masses are relatively distant) and an alignment zone. The correct setting of the spring constant and damping coefficient can model the same behavior. Moreover, the relaxation length of the spring will determine the alignment distance. The controller scheme is resumed in figure 3-4.

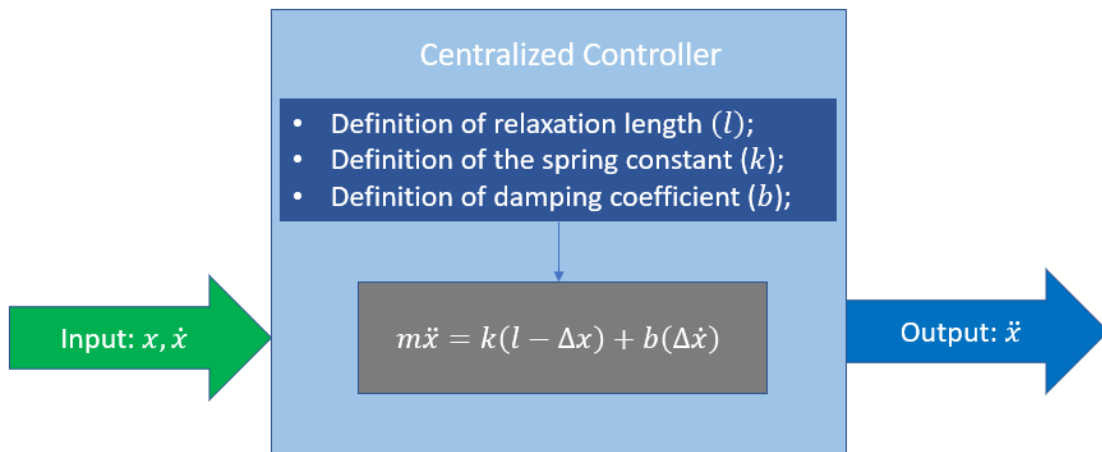

Figure 3-4 Centralized Controller scheme for two vehicles

We have just made an example which considers two vehicles. When a group of vehicles is into account, the previous considerations are applied multiple times, obtaining multiple individual spring-damper connections. A perturbation applied to whatever car in the system will be transmitted to the rest of the vehicles. In a realistic highway situation, the disposition of the vehicles may be similar to the one shown in

figure 3-5 a). In addition to what we have said for the case with only two vehicles, now we see an environment in which the spring-damper relations are not directly derived. While between two vehicles the univocal relation is settled between the two cars, in a multiple-vehicles multiple-lane environment the association is not direct. In figure 3-5 all the spring-damper relations are represented by means of arrows. Under normal conditions (figure 3-5 a), the relations may be considered solely in the longitudinal direction. Assuming that the car in the rectangle develops an event (e.g. transition), the relations may change. Figure 3-5 b) shows how the car transitioning is related to multiple vehicles also in adjacent lanes. In chapter 2.1 we have analyzed experiments demonstrating that after a transition a vehicle may switch lane involuntarily. Hence, during a transition, the future path of the vehicle transitioning enters in direct relation with the movements of vehicles in other lanes. Thus, the controller should take into account their correspondences by creating spring-damper relations between them. Figure 3-5 b) shows these relations.

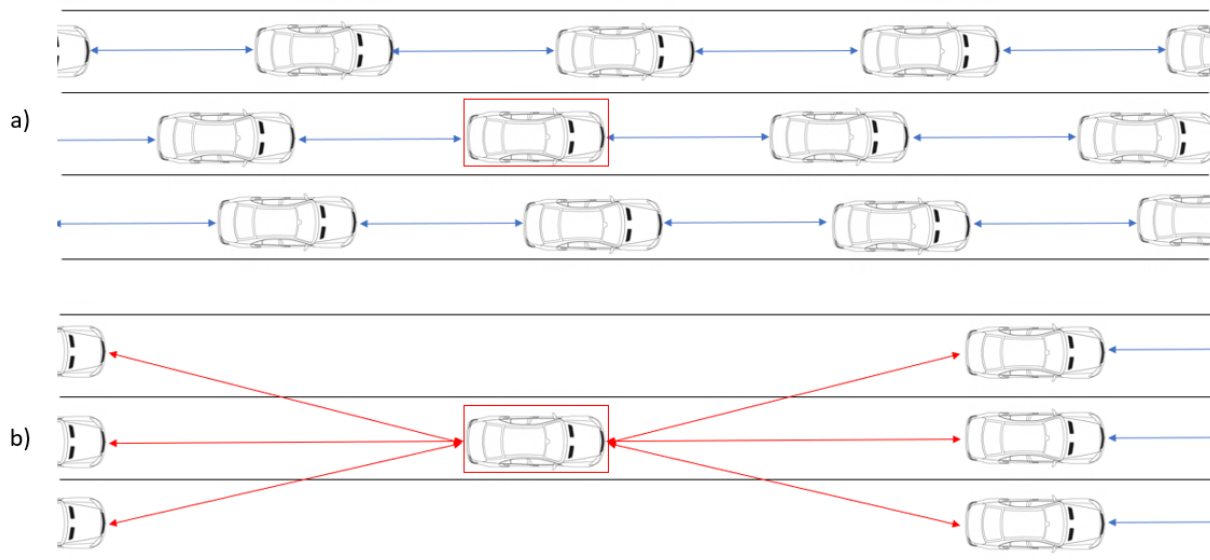

Figure 3-5 Scheme of disposition for high-density traffic before the transition a) and after b)

The scheme of the Centralized Controller considering this additional factor is shown in figure 3-6. The concept is the same as before, but we are considering a further step. After having received traffic state inputs, we need to define which the relations between the vehicles will be. Hence, we are deciding the relations (arrows in 3-5) over which we will define the spring-damper correspondence. When we are analyzing a group of vehicles, the definition of the fundamental parameters (spring constant, damper coefficient, relaxation length) is done for each relation, which underlies proper individual conditions.

The SMD controller is based on the concept of mechanical equilibrium. A body is in mechanical equilibrium when the total force applied to it is equal to 0; hence, also the acceleration of the body is equal

to 0. The mechanical equilibrium, in our system, represents the condition in which all vehicles are neither accelerating nor decelerating. For a SMD system, the mechanical equilibrium is defined by the combination of springs and their characteristics (relaxation length, spring constant). Varying these parameters, we can change the equilibrium state. Optimal combinations of parameters can define a mechanical equilibrium that satisfies the safety/efficiency requirements of all vehicles. Once the equilibrium is defined, the Centralized Controller will receive in inputs the actual position and speed of all vehicles and send back indications on how to reach the desired disposition (equilibrium).

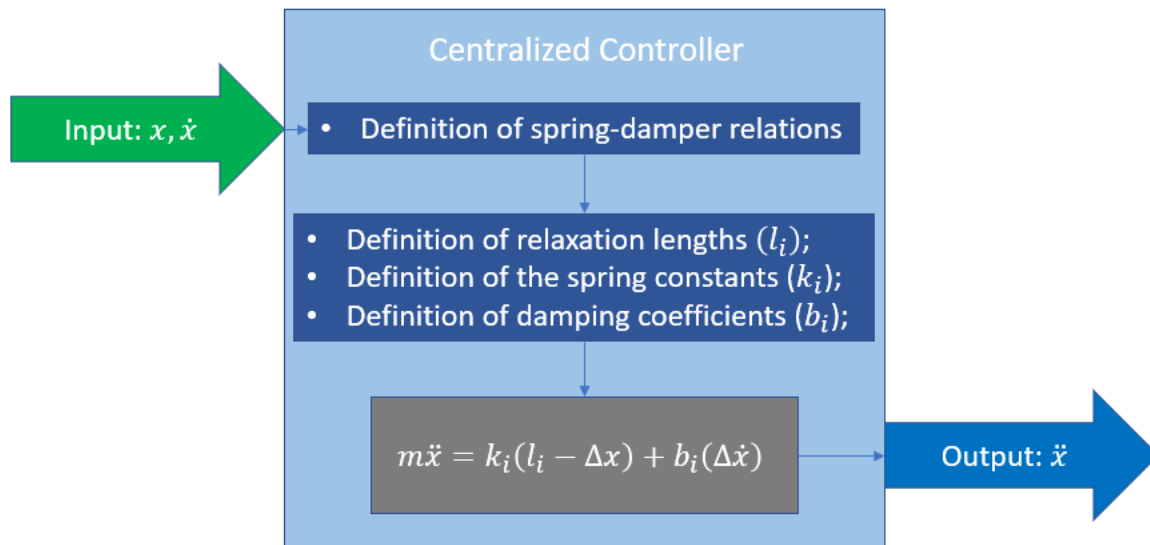

Figure 3-6 Scheme for the Centralized Controller for multiple vehicles

The protocol will pursue a continuous exchange of information between the vehicles and the server. The flux of data will be achieved through the cellular communication network. What is central to our model is how the data will be processed. The majority of functionalities are given to the Centralized Controller, instantiated in our case in the server. The vehicle's role is mostly to elaborate the data received and update its states to the server. In the following, we will show the characteristics of the Centralized Controller. Then, Chapter 3.3 will treat the application that is run in the processing unit of the vehicles. These consist of all the passages which elaborate the information flowing through the system.

3.2 Centralized Controller

The analysis of the process is made step by step, here the main parts:

- Input Management;
- Definition of Vehicle Relations;

- Proprieties of Relations;
- Acceleration's Computation;
- Commands Forwarding.

At first, the server must be made aware of the positions of all the entities in the environment. Next, the Centralized Controller will analyze all the information gathered, in order to define which are the relationships between vehicles. This means that for each vehicle, it will be defined which other entities it will take into account. After having defined the relationships, it will be needed to state which are the physical proprieties of these relations. It means to insert the spring-damper characteristics for each relation. Once this process is complete, each relation will address an acceleration to the related bodies. Each car is likely to have multiple relations, the acceleration resulting from the sum of all the components will be then sent as output to each vehicle. In the next, all these steps will be analyzed.

3.2.1 Input Management

Before the request of help is sent to the network, it is assumed that the server is not taking track of the positions of the entities on the road. In fact, automated driving may be achieved based on V2V communication together with vehicle sensor detection and map data, with no need to upload any information. Hence, vehicles may not overload the network with information not needed.

Once the request of help is sent from the vehicle transitioning to the network, the latter will realize the developing situation, and it will instantiate the Centralized Controller. The server will also request to all vehicles to send updates of their position with a specific frequency to the network. The messages sent are known as Cooperative Awareness Message (CAM), and they contain information such as position, speed, lane, and time stamp, together with the ID of the vehicle sending it. The frequency at which this message will be sent in the real case is not precise yet. For this project, it is assumed a frequency of 10 Hz that correlates to the timing requirement defined for DSRC use cases [75]. 3GPP proposes the usage of ITS-G5 standards for C-V2X applications. The frequency should be high enough to have an approximately continuous view of the environment on the server. In the future, it will be possible to detect the absolute position of the vehicle directly from the network, as explained in Chapter 2.2 speaking of new positioning features. However, to analyze the worst-case scenario, here it is assumed that the position of vehicles can be retrieved only by the vehicle. In this way, the server is conscient of a particular position but not sure of its evolution, until a new message from the same vehicle arrives. Higher the frequency of messages sent by the vehicle, smoother it is the view that the server has of vehicle positions. The frequency of the messages should also be low enough to give the network the possibility of moving all the messages inside the simulation. If we raise the frequency too much, the server will be overloaded, some packets will be dropped, and this will dramatically decrease the performance of the application. From the simulation results and

literature experience, 0.1 s as the time interval between consecutive messages of an individual vehicle has been found to be a decent compromise between the two sides.

Moreover, in Chapter 2.2 it has been driven that the accuracy for the next-generation positioning system will be lower than 0.5 m. When we retrieve the position on the vehicle through the simulator, the precision is absolute. A stochastic number is added to compensate the oversized accuracy of the software.

Once defined the frequency at which the messages will be sent, and their contents, it has to be understood how the Centralized Controller will manage them. The first thing the controller will analyze is the ID of the vehicle. The controller will create a data struct of dynamic dimension to adapt to the number of vehicles (and then amount of information) to be stored inside of it. If it is the first time that the ID of the vehicle is recognized by the controller, the data struct memory will be increased in order to create space for the proprieties of this vehicle. Then, position, speed, lane and time sent will be saved into it. On the other hand, if the controller receives an ID already present in its memory, it will open the memory dedicated to the specific vehicle and update position, speed, lane and new time-sent into this part of memory. If a vehicle exits the domain of interest (e.g. exits the highway), the Centralized Controller will free the amount of memory dedicated to it.

As a result, we have a dynamically expanding and compressing memory that will track and update all the values of interest relative to all vehicles involved, without consuming neither more or less than the memory needed for the operation. The amount of data to be analyzed by the controller is one of the reasons why it is difficult to physically implement an algorithm of this type without being aided by the network. In the network, a multitude of powerful computing facilities are already present, and new resources will be introduced in the next years in different logical positions of the network. This will provide the possibility to analyze a large amount of data. It is also more efficient to centralize the computation inside a single unit on the server. This possibility can be given by C-V2X technology while it is not provided by standalone DSRC.

3.2.1.1 Approximating Position Variation with Constant Speed:

It has been previously said that the 10 Hz of frequency for the messages is a good compromise between continuity of updates and load of the network. Assuming that in the highway a vehicle could drive at 130 km/h, it would move of approximately 36 m every second and 3.6 m every 0.1 s (time passing between two consecutive messages). 3.6 m is of the same order of magnitude of a passenger car length, and uncertainty of this dimension may create misunderstandings to the algorithm when two vehicles are relatively near to each other.

The application will solve this issue continuously updating the position of the vehicles by considering the last speed recorded together with the difference between the time in which the speed was sent and the actual simulation time. Constant speed can be seen as an excellent approximation: even considering a sharp

constant deceleration of a specific vehicle (e.g. $9 \frac{m}{s^2}$), the velocity variation in 0.1 s (hence before the next update) will be equal to just 0.9 m/s. In this way, the error due to the discrete updates of position is drastically reduced. Hence, this error can be considered acceptable and non-influent for the results of the simulation.

Once completed the procedure, the Centralized Controller will possess available data on all the vehicles in the area. The next table shows the organization of the information.

Table 3 Dynamic Memory Allocated for each Vehicle

Vehicle ID	Position (x;y;z) [m]	Lane ID	Speed (x;y) [m/s]	Time sent [s]
1	1160,45 ; 29,8 ; 2	1	35.56 ; 0 ; 0	34.120
2	1136,36 ; 26,6 ; 2	2	35.67 ; 0 ; 0	34.125
3	1133,12 ; 33.2 ; 2	0	36.11 ; 0 ; 0	34.137
4	1129,85 ; 29,8 ; 2	1	35.40 ; 0 ; 0	34.111

In table 3, only the proprieties relative to four vehicles are shown. When a higher number of vehicles is considered, a larger number of lines is stored in the Centralized Controller memory. The speed components in y and z are always 0 because the environment into account is constituted by a straight highway with no inclination.

In the future, cellular positioning will aid the GNSS system in retrieving position and speed value directly from the network and for the network. Since not enough literature was available to model position retrieval through the cellular communication network, we have assumed to exploit the well-known satellite positioning technology to gain information on the vehicle and successively send the same data to the server. This is a less efficient way for the network to achieve the position of vehicles, but the simulations will demonstrate that it still satisfies the requirements for our application.

3.2.2 Definition of Vehicle's Relations

As said, the traffic control method used will be based on spring-damper relations between vehicles. Before introducing the criteria used to define the parameters of each spring-damper connection, we need to show how the entities will be related to each other. While the answer is logically direct when analyzing a single lane simulation (each vehicle is connected to the first one in front of it and the first one behind it), it is not obvious how to define the relations when multiple adjacent lanes are present.

The connections between vehicles are thought to be unambiguous. It means that if vehicle A is connected to vehicle B, vehicle B must be connected vehicle A. A vehicle relation is created based on the interest that two vehicles should have in each other's paths. Assuming no lane changing is developing, vehicles driving in average condition will not be interested in the behavior of vehicles in adjacent lanes. A car should instead

pay attention to the vehicle that it is following. Moreover, in an autonomous environment, it is interesting to directly correlate also the follower vehicle, since autonomous vehicles can have 360 degrees view and there is no discrepancy between analyzing data coming from behind or in front. Vehicles operating in normal conditions, thus, are directly connected to the follower and the following vehicles. The relations of autonomous vehicles without transition are shown in figure 3-5 a).

When, instead, we apply the concept of interaction to the vehicle handing over the commands, the situation changes. A qualitative description of the lateral irregularities deriving from the transition has been made in Chapter 2.1. The irregularities may have as a consequence involuntarily lane switching. Hence, we understood that the behavior of this specific vehicle might interest the adjacent lanes. In this way, the desired composition of relations of the vehicle transitioning will also regard the ones in adjacent lanes, as shown in figure 3-5 b).

In practice, the Centralized Controller will rely on the memory space allocated regarding the inputs. This is the view that the Centralized Controller has of the environment. The interesting data about all vehicles involved are recorded and updated in this space, and it is easily readable. The Centralized Controller will then have knowledge of the disposition of the group of vehicles, and it will apply the concepts derived for the relationships online. Another consistent part of memory will be allocated in this way for each vehicle. The variables of interest for the connection are the relative position between vehicles, the relative speed between vehicles, the angle between the orientation of the first vehicle and the segment connecting the first and the second vehicle. Each vehicle involved will have a data struct containing all the parameters listed above for each relation that has been created. The data are organized as shown in table 4.

Table 4 Data struct for vehicle relations

Connected Id	Relative Distance [m]	Angle [°]	Relative Speed [m/s]
17	23.15	-130.67	-1.1
0	35.12	180.00	0.7
5	40.17	0.00	0.1
12	27.76	-45.95	-1.2
6	35.67	99.42	0.5

3.2.2.1 Analysis Involving Relative Speed, Acceleration/Deceleration Capabilities and Time Buffer:

The issue of the previous analysis is that the relations have been created by only considering the position of the vehicles. The spring, once modeled, will act based on its geometrical disposition (if no further indication is given). It means that if a vehicle is positioned in front of the one transitioning, and after the spring is inserted it results compressed, the spring will always push the vehicle with a positive acceleration

(figure 3-7 a)). This behavior may be correct or inefficient based on different vehicle characteristics. The optimal behavior is related to the relative speed between vehicles, the acceleration/deceleration capabilities, and the available time buffer.

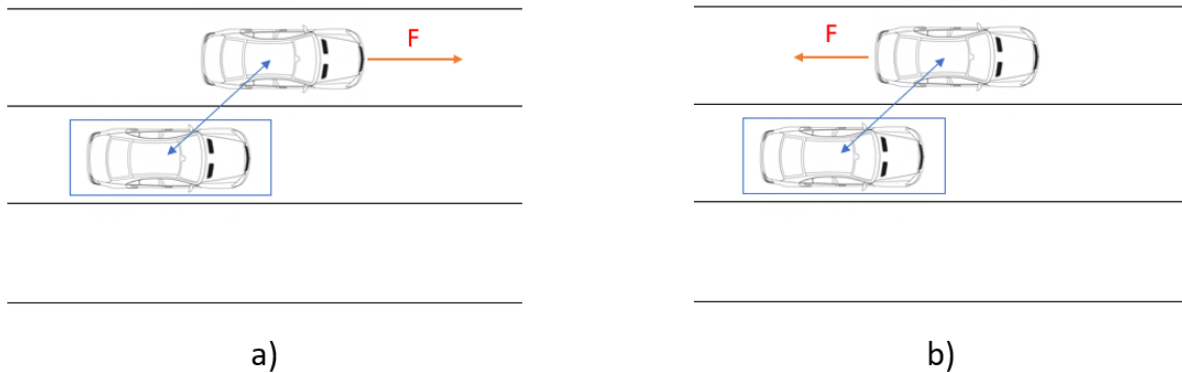

Figure 3-7 Force of the spring based on geometrical disposition a) and optimal behavior b)

To clarify, let us assume that a vehicle in the motorway, driving and 120 km/hr, is in the adjacent lane of the one experiencing the transition, just 0.5 m in front of it. At this moment, the Centralized Controller will model the spring connection just based on the geometrical disposition. The algorithm will execute the equation of the spring-damper system. If there is a need for freeing space, being connected in front, the output will be a positive force pushing the vehicle forward, as in figure 3-7 a). It means that the vehicle will try to accelerate, and this would make complete sense just in the case in which the acceleration and deceleration capabilities of the vehicle would be the same. On the road, and furthermore at 120 km/hr, this is usually not true. The task is to free the space needed within the available time buffer and this could often happen when a vehicle position slightly in front than the one transitioning uses the brakes instead of accelerating (figure 3-7 b)). Another valid point is the case in which a vehicle is driving on the adjacent lane at a higher speed than the one in transition, and at the moment in which the analysis starts it is 0.5 m behind the vehicle transitioning. Also in this scenario, due to the higher relative speed, the best choice may be to relate it in front of the vehicle handing over, pushing it forward to clear the critical space.

Hence, the first analysis creates a lack due to the oversized simplicity of the protocol. In order to react to this problematic, an additional algorithm has been generated. The procedure is the following:

- Once understood the available time buffer, and the space requirements of the vehicle transitioning, the average acceleration/deceleration needed for each vehicle to free the critical space is known.
- The acceleration and deceleration are compared with the ones that the vehicle can fulfill at its current speed.

- Moreover, the calculation is compensated to consider the fact that the vehicle cannot exceed the law speed of the motorway (in our cases assumed equal to 130 km/hr).
- Based on vehicle positions, time buffer available, acceleration and deceleration capabilities, maximum speed acceptable, current speed, length of the critical space in both frontal and posterior directions, we can calculate which is the time needed to free the space in both frontal and posterior direction.
- At this point, the time needed to free the critical space is available for both directions. If space can be cleared in both ways, the one which has a lower change in speed is chosen. Else way, it is just needed to choose the shorter.
- Once the most efficient behavior has been chosen, the Centralized Controller will model the verse of the relaxation length accordingly. Hence, the vehicle will accelerate/decelerate toward it.

In this way, the relations built between vehicles are considering multiple factors. Vehicles will be related to the optimal ones not based on the initial position, but instead on the disposition that the Centralized Controller has found to free the space needed in the most efficient way.

3.2.3 Proprieties of the relations

The relations of each vehicle are now known. It is still undefined, instead, which is the physical response caused by these relations. The group of vehicles will behave like a flock of birds. Birds update their velocities by averaging them out over their nearest neighbors. However, when we see birds flying, it seems to us that their movements are harmoniously controlled [76]. In the same way, each vehicle will regulate its behavior regarding the position and speed of its neighbors, converging synchronously as a group toward the desired disposition. In order to create a response based on the relative speed and position of vehicles, the equation hiding behind the relation must be set. The rules used by birds have been built within their evolution, and we must define analog guidelines that vehicles will follow. We have already introduced that the Centralized Controller will develop its algorithm with SMD relations. Vehicles, such as birds, will be interested in moving together without impacting each other. Position, speed, acceleration, and orientation are the parameters of interest to achieve the results. The spring-damper system considers them all. Hence, it is not surprising that the SMD system has been taken into consideration to model birds flocking [77]. In analogy, we will use the same concept to develop a cooperative reaction for vehicles. The purpose of the system is to provide self-organization capabilities. The different circumstances in which this can be useful comprehends aiding a vehicle while joining a group (e.g., ramp entrance, platoon formation [22]), modifying space requirements for a vehicle (e.g., transition, drowsy driver) or just managing acceleration/deceleration of all vehicles under steady-state traffic conditions.

In our case, the necessity is to enlarge the quantity of free space around a vehicle transitioning. Before the transition, the relaxation length of the spring connected to this vehicle is the same as all the other

participants with the same proprieties (steady-state traffic condition, figure 3-5 a). Hence, it will have the same relative distance from the other participants that all the other vehicles have. When the transition is detected, its spatial requirements are changing. Thus, the relation length will be accordingly increased, and this will result in all the connected environment moving to satisfy the new requirements (figure 3-5 b)). The spring will have a particular stiffness constant that will condition the speed of the response. Moreover, the damper is present to provide stability and avoid oscillation in the alignment zone. The values used for spring constant, damping constant, and relaxation length are due to a series of factors that will be discussed in the following.

In our simulation, a group of vehicles will be involved, and each vehicle will possibly have multiple relations. The subsystem characterizing each relation is shown in figure 3-8 b).

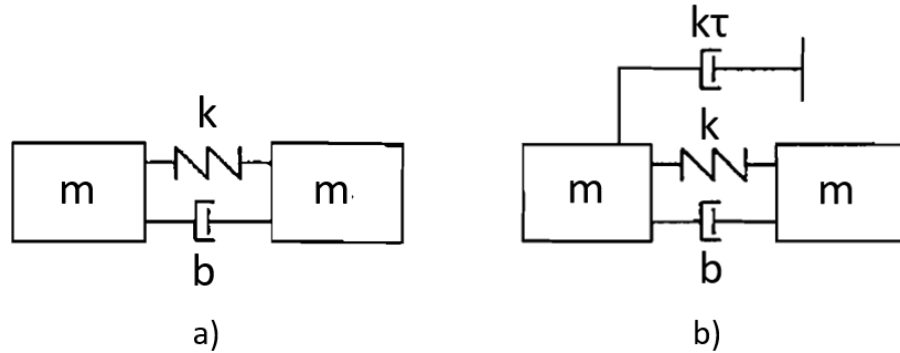

Figure 3-8 SMD system a) and constant time headway in SMD system b).

Figure 3-8 a) shows a standard SMD system. The damping component $k\tau$ has been added in order to increase the stability of the system, as suggested by Eyre et al. [27]. The acceleration of the vehicle is bounded with relative position and speed as in equation (3.1).

$$m\ddot{x} = k(x_{n-1} - x_n - l) + (b + k\tau)(\dot{x}_{n-1} - \dot{x}_n) = k(\Delta x_n) + (b + k\tau)(\Delta \dot{x}_n) \quad (3.1)$$

Where:

- $\ddot{x}_n, \dot{x}_n, x_n$ represent the acceleration, the speed and the position of each vehicle;
- m does not represent the mass of the vehicles, it will be kept constant, and the other values will be set accordingly;
- k is the spring constant;
- b is the damping coefficient;
- l is the relaxation length of the spring, the distance at which two vehicles will not be either attracted or repulsed by each other;
- τ is the response time.

Equation (3.1) comprehends values that are taken as inputs from the environment (position and speed of all vehicles), values depending on the particular conditions and vehicle proprieties (mass of the vehicle, spring constant, damping coefficient, response time) and acceleration as only output. Relative position and speed for each relation are gathered as defined in Chapter 3.2.2. Hence, they will be directly inserted inside equation (3.1). We must now see which are the choices for the missing parameters in the equation. In particular, we are going to define the values for relaxation length of the spring, spring constant, and damping coefficient. In the following, we will show the analysis that has brought to the decision of these parameters.

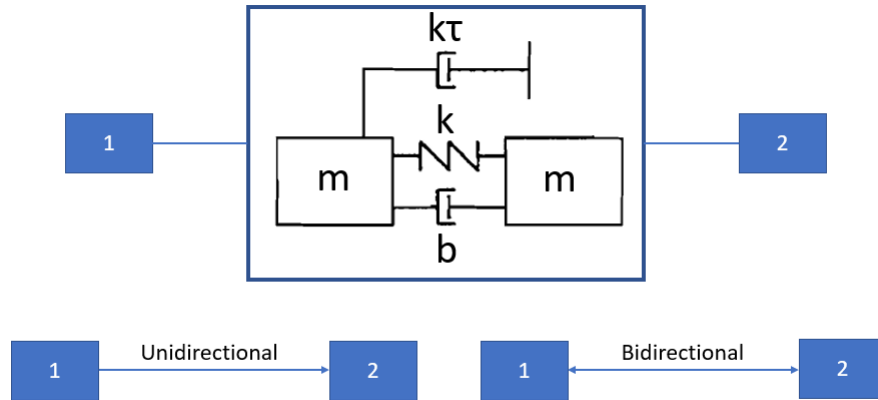

Figure 3-9 Bidirectional and Unidirectional representation

In the following, the coupling of figure 3-8 b) will be symbolically shown by means of arrows. Moreover, we will introduce in chapter 3.2.4 the concept of unidirectionality and bidirectionality. When a particular vehicle 2 will be influenced by vehicle 1, while vehicle 1 will not follow the behavior of vehicle 2, the coupling will be defined unidirectional. In the bidirectional case, the vehicles will be coupled in both senses. In figure 3-9, the representation method is shown.

3.2.3.1 Relaxation Length of the Spring:

The length of the spring is the value that will define the spacing between two vehicles when they are in a steady-state condition. When there is no irregular interaction with the traffic flow, the vehicles will proceed on the road with a constant spacing. The spacing between two vehicles is mainly concern by two variables:

- The driving speed;
- The reaction time.

Equation (3.2) shows how the parameters are bounded. The concept of the application is to free a certain amount of space around the vehicle, and this is done by changing the parameters that interest the relaxation length according to the event developing.

$$l = \tau * \dot{x}_n \tag{3.2}$$

\dot{x}_n is input and we cannot rely on changing it. The parameter of interest is τ . It represents the time gap needed between two vehicles in order to be able to react to a drastic behavior of the one in front. Autonomous vehicles have a lower reaction time, hence under normal traffic conditions they will be able to keep a shorter gap between them. When the transition is developing, the distance will be adjusted to the human reaction time for the vehicle transitioning, increasing the distance between the latter and its neighbors. In table 5 reasonable values for time spacing and distance are shown.

Table 5 Reaction Time in autonomous and manual mode and longitudinal distance at 36 m/s

Mode	τ	$s = \tau * \dot{x} \left(\dot{x} = 36 \frac{m}{s} \right)$
Autonomous	0.8 s	28.8 m
Human-Driven	2.0 s	72 m

In standard car following models, τ relates the vehicle with the one in front of it in the same lane. For our simulation, we will add two further considerations:

- Since the transition may cause a wrong path of the vehicle subjected to it, with consequent involuntary switching of the lane, the vehicle transitioning will also consider the time gap from vehicles in the adjacent lanes.
- Moreover, one of the consequences of relatively long and trusted autonomous driving is the loss of situation awareness. The human retaking control finds difficulties in elaborating, in the first moments after the transition, the amount of data that manual driving requires. The human driver needs to scan both forward and rearward sections of the environment to provide safe driving. Since he will not be ready to analyze environmental data (e.g. position of other vehicles) after the transition, it has been decided to clear space also in the backward direction. In this way, the pilot gaining controls will have less information to focus on and he will be able to concentrate on safely acquiring the controls of the vehicle. In addition, it is considered that after the transition the driver is likely to decelerate. Having allocated some space between it and its followers, the deceleration of the human-driven vehicle can be absorbed more efficiently.

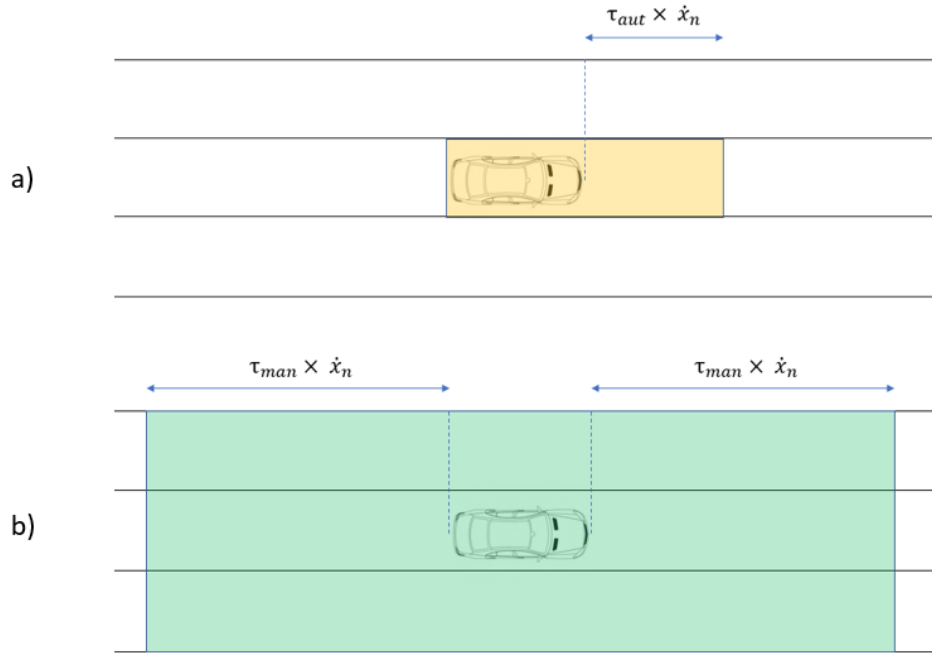

Figure 3-10 Space allocated for a safe driving condition for an autonomous vehicle a) and a vehicle after transition b)

Standing on the previous considerations, we can define the minimum space required for each vehicle on the road. The minimum space will coincide with the relaxation length of the spring since it defines the alignment distance of the bodies. For vehicle driving in autonomous mode, the space needed for safe driving is represented in figure 3-10 a). It interests only the current lane and the forward direction; the length is equal to $\tau_{aut} * \dot{x}_n$. The requirements of the vehicle transitioning are the most significant (figure 3-10 b)). Adjacent vehicles in all three lanes will be subjected to it. The space needed in the forward direction is equal to $\tau_{man} * \dot{x}_n$. A backward spatial requirement is introduced to aid the pilot in regaining situation awareness quietly. In our simulation, the length of the rearward area is set equal to the frontal length ($\tau_{man} * \dot{x}_n$). However, we have at our disposition studies that indicate the importance that clearing space behind the vehicle might have, with no quantitative result. Hence, we have introduced this variable conscious that in the future the absolute value may be redefined.

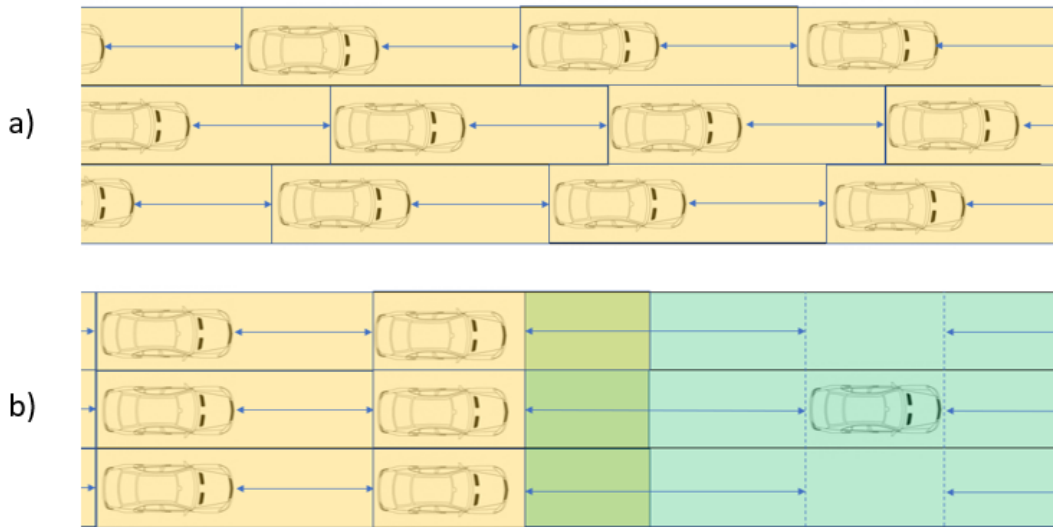

Figure 3-11 Space allocation before transition a) and after b)

Figure 3-11 shows how the allocation of spatial resources will work. Each vehicle will possess specific spatial requirements, and the Centralized Controller aims to satisfy them all. The simulation will start in a high-density scenario with a penetration rate of 100 % of autonomous vehicles. Hence, all vehicles will find their position on the road by keeping their distance regarding the following vehicle. A realistic disposition is shown in figure 3-11 a). At the moment in which a vehicle will start the transition, the relaxation length of the springs connected to the vehicle transitioning will be changed and set equal to $\tau_{man} * \dot{x}_n$. In figure 3-11 b) it is shown the safe disposition which is required after transition. The area around the vehicle transitioning should be freed before the end of the time buffer.

3.2.3.2 Spring Constant:

The relaxation length of the spring will define the mechanical equilibrium of the system. Hence, the alignment zone of the vehicles is determined, and we can satisfy the spatial requirements of each vehicle by setting the relaxation lengths accordingly. The spring constant will define the rapidity with which the system will converge in the alignment zone.

The spring constant represents the stiffness of the spring. Higher it is the stiffness, faster it is the reaction and the time to reach the new equilibrium is lowered. This constant is the primary variable that will interest the acceleration kept by the vehicles. To set this variable, it has been decided to consider equation (3.1) leaving out the component due to the damper:

$$ma_x = k_x(x_{x-1} - x_x - l) \quad (3.3)$$

Dividing for the spring stretch:

$$k_x = \frac{ma_x}{\Delta x_x} \quad (3.4)$$

Where:

- $m = 1000 \text{ kg}$ (assumed the same for all the vehicles);
- $\Delta x_x, a_x$ are instead the variables that can be adjusted in order to define k flexibly.

The mass of the body, in a real SMD system, will define the fatigue to convert the spring energy in the kinetic energy of the body. It will hence define its acceleration. In a vehicle, the acceleration is dependent on other variables more than the mass, such as the power of the engine. Thus, it is not possible to set m equal to the mass of the vehicle and obtain the correct behavior. In our simulations, m will be set equal to 1000 kg. It is the first parameter to be defined, then the rest of the system is settled around of it. Using different masses, all the other parameters would be adjusted accordingly without changing the outputs of the controller. It is the only variable that has no representation in the adaptation of the SMD system for our controller.

Hence, it all comes to the definition of Δx_x and a_x . a_x is dependent on the rapidity with which we want to complete the procedure. If the analysis for the time buffer demonstrates that plenty of time is available for the transition, the acceleration/deceleration will be kept small. While the time buffer decreases, the movements of the vehicle will always become more drastic, until the point in which the acceleration/deceleration needed for the execution will be the same as the maximum one that the vehicle can actuate. At this point, it will not be possible to complete the operations in time before the end of the transition, and it will be just a matter of reducing the risk as fast as possible.

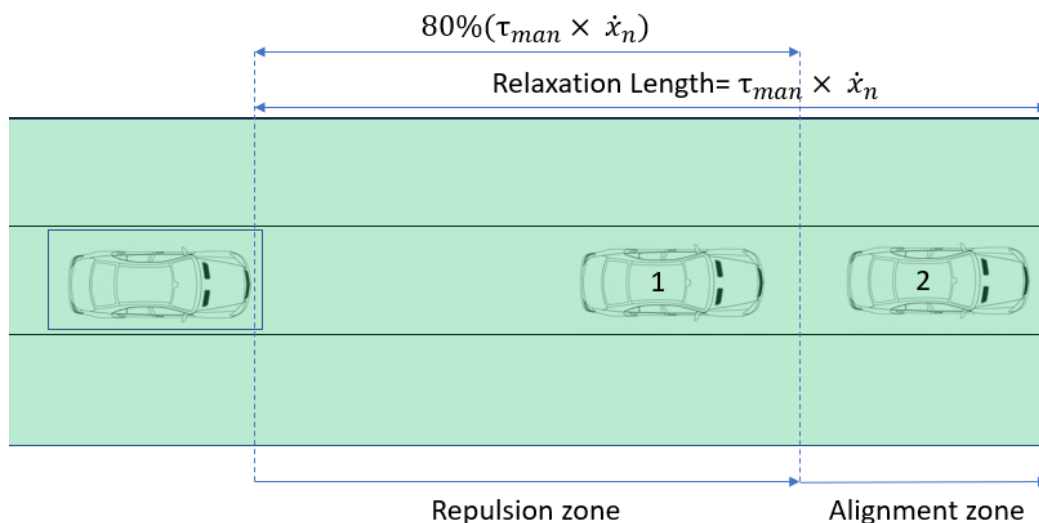

Figure 3-12 Repulsion and alignment zone scheme

Assuming that a particular transition time (t_{buffer}) is available, we can compute the average deceleration/acceleration needed in order to free the space around the vehicle transitioning in time. In particular, we divided the total space (equal to the relaxation length) into two components: a repulsion zone and an alignment zone. Referring to figure 3-12, a vehicle is positioned in the repulsion zone while it has not reached 80% of the total space it is needed to free. The vehicle transitioning is the one in the box; vehicle 1 is positioned in the repulsion zone. Until a vehicle is positioned in the repulsion zone, it is needed to exploit relatively large acceleration/deceleration in order to clear the space in time. The alignment zone instead represents an area that is already relatively far from the vehicle requiring the space. Vehicle 2 is in the alignment zone. It is exploited in order to reach the desired position without oscillations. Acceleration will smoothly converge to 0 while the vehicle reaches its desired speed and position. The end of the repulsion zone thus indicates the quantity of free space acceptable at the end of the transition. It has been decided to set it as 80% of the total, but this value can be changed if required.

For the vehicle transitioning, the length of the space to be allocated is equal to $\tau_{man} * \dot{x}_{tran}$, and the acceptable value is equal to 80% ($\tau_{man} * \dot{x}_{tran}$), where \dot{x}_{tran} is the speed of the vehicle after the transition. a_x is defined as the average acceleration that can bring the vehicle out of the repulsion zone within the time buffer, if it starts to move from the same longitudinal position of the vehicle transitioning. As a consequence, $a_x = \frac{2s}{t_{buffer}^2}$, where $s=80\% (\tau_{man} * \dot{x}_{tran})$. Under realistic circumstances, the following values for all the terms are possible:

Table 6 Numerical example for the definition of K_x

τ_{man}	2.0 s
\dot{x}_{tran}	30 m/s
s	48 m
t_{buffer}	10 s
a_x	$0.96 \frac{m}{s^2}$
k_x	$80 \frac{kg}{s^2}$

In this experiment, k_n is settled in order to provide a_x until the vehicles are out of the 80% of the area. Hence, the spring is giving the maximum acceleration a_x when the vehicle is at a distance equal to $20\%(\tau_{man} * \dot{x}_{tran})$ from the relaxation length. In this way, Δx_x is decided equal to $20\%(\tau_{man} * \dot{x}_{tran}) = (\tau_{man} * \dot{x}_{tran}) - s$.

The equation for the spring stiffness thus becomes:

$$k_x = \frac{ma_x}{\Delta x_x} = \frac{m * 2 * 80\%(\tau_{man} * \dot{x}_{tran})}{20\%(\tau_{man} * \dot{x}_{tran}) * t_{buffer}^2} = \frac{m * 2 * 80\%}{20\% * t_{buffer}^2} \quad (3.5)$$

The constant is dependent only on the percentage of space to be freed and on the time buffer.

The considerations made above reflect which are the needs of the vehicle transitioning. After the transition, the gap between the latter and the other vehicles is reasoned to be almost 2.5 times higher than before the handover. Hence, a relatively large amount of space needs to be cleared. For what regards the other vehicles, the spacing between them does not have to be extensively changed. The vehicles will move as a team to respect the requirements of the other parties, but the only vehicle for which the necessities have changed is the one with the transition. Since the difference between the two cases exists, it is also reasonable to compute two different solutions.

The concept of keeping the same gap before, during and after the operations between two vehicles traveling in autonomous mode, can also be revisited by saying that a faster response is needed between vehicles continuing autonomous driving. In order to keep the same distance, the vehicles must adapt faster to change of speed of the one that is transmitting the perturbation. We can thus define a more considerable value for the spring constant. Analytically, this is done as follows.

$$k_n = \frac{ma_n}{\Delta x_n} \quad (3.6)$$

$$a_n = \min(1.5a_x, a_{max}) \quad (3.7)$$

$$\Delta x_n = 20\%(\tau_{aut} * \dot{x}_n) \quad (3.8)$$

$$k_n = \frac{m*1.5a_x}{20\%(\tau_{aut}*\dot{x}_n)} \propto \frac{1}{\dot{x}_n} \quad (3.9)$$

For what regards the acceleration in this second case, it is decided to increase it of a 50% margin ($a_n = 1.5a_x$). This margin has no specific quantitative reason, but it provides a qualitative behavior more reactive for vehicles that want to preserve their original time ahead. Moreover, since we are not able to know in advance if this acceleration exceeds the maximum one that the vehicle may provide, the minimum between desired and maximum acceleration is set, as shown in equation (3.7). As a comparison to the previous case, the idea for the spring is to provide this acceleration at the limit of the alignment zone. The alignment zone is thought to be equal to $(1 \pm 0.2)(\tau_{aut} * \dot{x}_n)$, hence the stretch distance at which we will calibrate the acceleration is derived from equation (3.8). As before, a numerical example with practical values is shown in table 7:

Table 7 Numerical example for the definition of K_n

τ_{aut}	0.8 s
\dot{x}_{tran}	36 m/s
Δx_n	7.2 m
a_n	$1.44 \frac{m}{s^2}$
k_n	$120 \frac{kg}{s^2}$

As a consequence of this second case, the stiffness of the spring will be inversely correlated to \dot{x}_n , as shown in equation (3.9). At lower speeds, the distance in meters between two vehicles will be reduced (since the time gap between them will be kept constant) and their action will be strongly related.

In conclusion, two different roads have been taken in order to define the spring constant. The vehicle in transition will have the definite necessity of increasing the space around itself. The rapidity of the process will be defined by the time buffer available, and the minimum acceleration to provide this requirement will be taken into consideration in the definition of the constant. Vehicles proceeding in autonomous mode, instead, will have no necessity in increasing space between them. They will follow each other with the same time gap as before. For this reason, it has been decided to provide higher stiffness in order to increase the reactivity to perturbation, resulting in lower variation of the gap between autonomous vehicles while executing the protocol.

3.2.3.3 Damping Constant:

The damping coefficient b_n represents the degree of resistance that is going to mitigate the force created by the spring. The damping force makes a vehicle approaching the alignment distance smoothly, and it helps to maintain the same speed without oscillation around the equilibrium state. Hence, a large b_n increases the time needed by the bodies to position themselves at a distance equal to the relaxation length. On the other hand, a small b_n would give a condition in which the vehicle would oscillate in both position and speed before stabilizing at a distance equal to the relaxation length. The right compromise between the spring coefficient and damping constant must be found in order to provide efficiency and stability to the control system.

It is essential to know that there are critical combinations of k_n and b_n which give the possibility to reach the relaxation length in the fastest way as possible without any oscillation around the position. Once set a critical combination, reducing the value of b_n will bring oscillation; increasing it will enlarge the time needed to reach the equilibrium. For example, in a simple one body SMD system, the motion can be expressed as follows:

$$m\ddot{x}_n + b_n\dot{x}_n + k_n x_n = 0 \quad (3.10)$$

The stability analysis, for this system, shows that once settled the value for k the critical damping is equal to $2\sqrt{km}$ [78]. Thus, $b_n > 2\sqrt{km}$ represents the overdamping condition, and the time needed to reach the relaxation length will be longer than in the critical damping case. Last, $b_n < 2\sqrt{km}$ is the under damping condition, and a vehicle following a motion of this type would oscillate back and forth before stabilizing at the desired distance. In an ideal system, after having decided the spring constant, b_n would be set to respect precisely the condition of critical damping to provide maximum efficiency. However, given the sources of imprecision due to the limited accuracy of the positioning system, and the not completely constant timing of message reception, it has been decided to be conservative and set the parameters to the overdamping condition.

Eyre et al. have given a quantitative comparison between different mass-spring-damper controller characteristics [27]. The analysis provides broad ideas that can direct the reader's mind toward the choice of specific proprieties for the control system. For our case, the coupling represented in figure 3-8 b) has been chosen. It refers to a controller with speed-dependent spacing, in which an additional damping constant equal to $k\tau$ that increases string stability. In the same paper it is also shown the demonstration for the parameter combination needed for critical damping. Here it will be just shown the condition in equation (3.11):

$$b_{crit} = \max\left(\frac{m}{\tau}, \sqrt{km}\right) \quad (3.11)$$

In order to achieve stability, b_n must be equal or larger than b_{crit} . As pointed out before, to give some margin to react to the imprecision of the system, a slightly larger value will be chosen. We have validated the analysis for the critical damping in a simplified single lane four-vehicles experiments where we have developed a perturbation similar to the one that will be propagated in our final experiment.

The graphs in figure 3-13 show the relation speed-time when the perturbation is created: all vehicles slow down to give space to the red one (proceeding at constant $36 \frac{m}{s}$), and then accelerate to reach the desired speed again. It is visible that the convergence is faster in the case of critical damping.

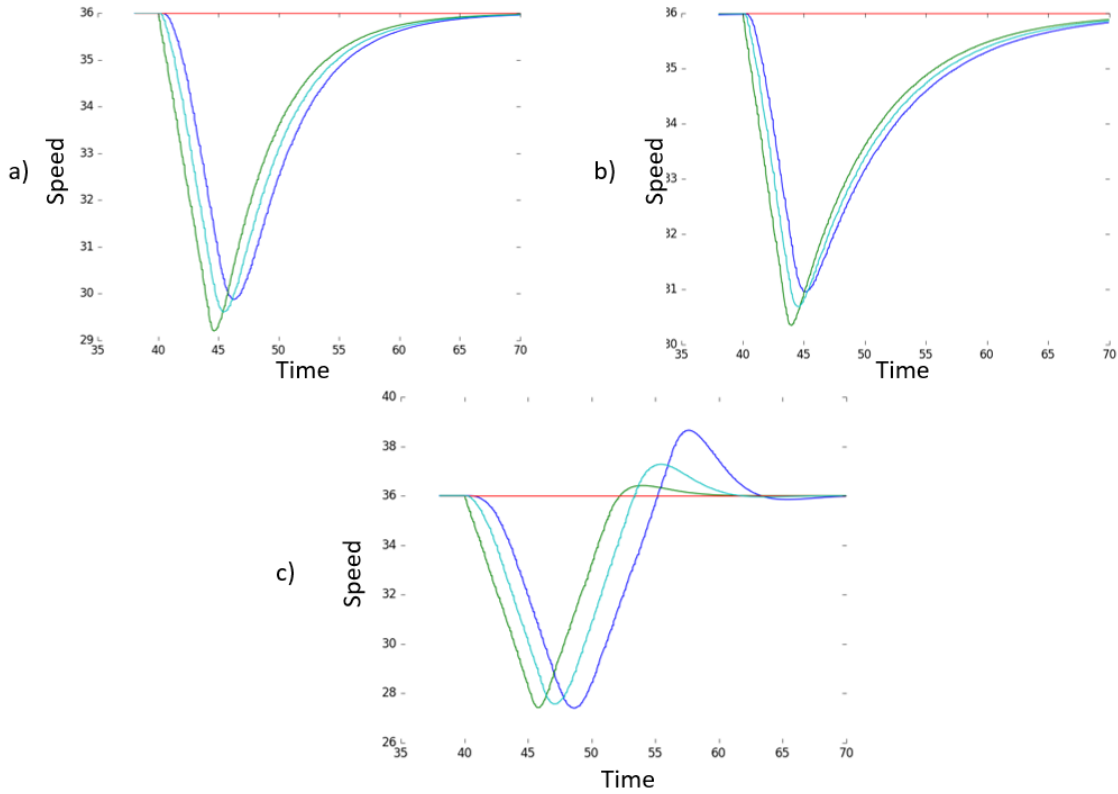

Figure 3-13 Single lane speed-time analysis for critical damping a), overdamping b) and underdamping c) conditions

It is not possible to define in a static way which will be the value for the damping coefficient because it is also dependent on the spring constant, and the latter is dependent on the speed at which the vehicle is moving. Consequently, also b_n will vary with the vehicle speed. As we have done previously, an example of practical values is given in table 8:

Table 8 Numerical example for the definition of B_n

m	1000 s
τ_{aut}	0.8 s
k_n	$120 \frac{kg}{s^2}$
b_{crit}	$1250 \frac{kg}{s}$
D	1.15
b_n	$1437 \frac{kg}{s^2}$

Where $b_n = Db_{crit}$ and D is the constant introduced to overdamp the system.

3.2.3.4 Considerations:

In the first part of the chapter, the control system that is going to be utilized to manage the traffic flow has been shown. It has also been pointed out that this system comes with variables that are in part extracted directly from the traffic flow condition (e.g., position and speed of vehicles), and some of them are instead defined online following the guidelines listed above. Now, all the values of equation (3.1) have been defined. As each bird gathered in a flock responds to the movements of its neighbor as they have naturally learned to, each vehicle is now conscious of which vehicles it has to consider, and the manner in which it has to evaluate their movements. After having done that, we can say to have inserted in the server a control system that will manage all vehicles in a cooperative manner. Each movement or requirement of whatever vehicle will be transmitted as a perturbation to all the others.

3.2.4 Output: Acceleration and Deceleration

Everything that has been said before has helped us understand which is the control method that lays inside the Centralized Controller. Moreover, a detailed explanation of the choice of the fundamental parameters has been given. Referring to the system shown in figure 3-8 b), we can say that for each relation, the following acceleration is developed:

$$\ddot{x}_n = \frac{k_n}{m}(x_{n-1} - x_n - l) + \frac{(b_n + k\tau)}{m}(\dot{x}_{n-1} - \dot{x}_n) = \frac{k_n}{m}(\Delta x_n - l) + \frac{(b_n + k\tau)}{m}(\Delta \dot{x}_n) \quad (3.12)$$

Of the previous equation, the right-hand side contains parameters that are entirely settled at this point. This means that, from each relation, the Centralized Controller can compute this equation with the data achieved and can directly extract the only variable that has been left out until this moment: \ddot{x}_n .

The computation is made in a decentralized way: the Centralized Controller has allocated a part of the memory for each vehicle that shows which are the vehicles at which it is connected. Hence, for each vehicle, it is already known which other entities it has to consider. In this way, the Centralized Controller will resolute equation (3.12) for each connection of the single vehicle, obtaining a sum of forces/acceleration applied to the body. The resultant of these forces will be sent to the vehicle. This process is going to be repeated for all the vehicles involved, obtaining finally a behavior similar to the case in which the bodies are connected with physical spring-damper connections.

3.2.4.1 Unidirectionality

The difference between a bidirectional or unidirectional system has already been explained in Chapter 2. In the bidirectional control scheme, each body is considered to be coupled to both the preceding and following masses. In this way, the system uses the information on both the immediately preceding and following vehicles while computing the acceleration. In the unidirectional control method instead, each mass is connected only in one direction, without being affected by what happens in the other. From our

simulation, it has been shown that while string stability can be reached with both control methods, the perturbation is absorbed in a better manner in the case of the unidirectional controller.

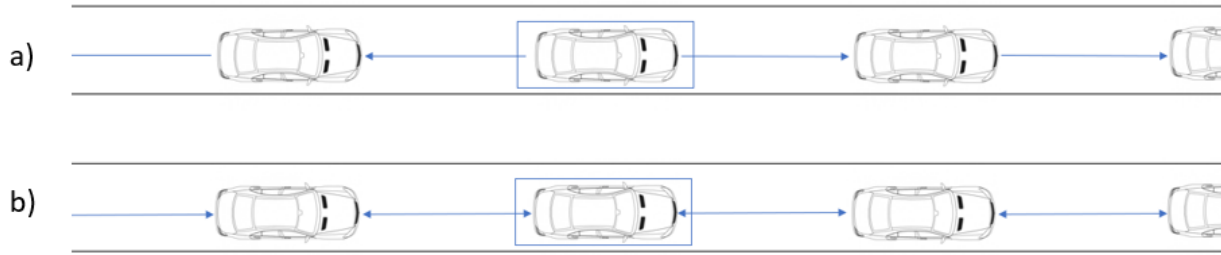

Figure 3-14 Single lane unidirectional relations a) and bidirectional relations b)

In our case, the perturbation is incoming when the vehicle starts the transition, and thus it changes its spatial requirements. In a high-density traffic scenario, the perturbation will uniformly propagate in both forward and rearward directions. A unidirectional coupling will receive an acceleration only from the direction from which the perturbation is incoming, while it will not consider the opposite verse. In this way, the vehicles positioned in front of the one in transition will receive the perturbation from the rear and will adjust their motion regarding only position and speed of follower vehicles. On the other side, vehicles will check the forward entity to decide their acceleration. The concept is shown by means of arrows in figure 3-14 a). Figure 3-14 b) shows the case with bidirectional coupling.

3.2.4.2 Bidirectionality for Safety

It is understood that the bidirectional controller reduces performances of the system, and for this reason a unidirectional controller has been chosen. However, the fact that a bidirectional controller will reduce the efficiency of the system does not mean that it will not improve safety for vehicles. In fact, when the connection is unidirectional, a sudden deceleration of the front vehicle may not be taken into consideration by the following, and this may result in a collision between them.

The reaction time of automated vehicles considered in our experiment is 0.8 s. From the literature, it is shown that the reasonable reaction time of automated vehicles in the next decade will vary between 0.6 s and 1 s.

Hence it has been decided to define a critical time gap $\tau_{crit} = 0.6$ s. If the time distance between two vehicles falls under this value, the bidirectional coupling will be activated, and the system behavior will change. Moreover, if some drastic disruption of the traffic flow (e.g., hard braking) develops, the bidirectional connection will also be activated for $\tau > \tau_{crit}$.

From our simulations, it is shown that under normal traffic flow circumstances, it never happens to fall in the condition in which the bidirectional coupling needs to be actuated. In this way, it is possible to exploit the performance given by the unidirectional system, with increased safety assured by the possibility of bidirectional connection activation.

3.3 Application Running in Vehicles

The discussion made on the application running in the server brings a clear definition of the way the acceleration sent to the vehicles is calculated. The server has a centralized view, and the SMD based control system can find the solution for the common good. Then, the server will send the resulting acceleration to each vehicle. Issues may arise because of the time needed for the computation, together with the possibility of losing packets during transmission.

On the one hand, the communication between the server and vehicles is subjected to a specific latency. Moreover, we have introduced an inevitable delay to justify the time of computation. The latency is directly managed by OMNeT++, based on the conditions of the system. For what regards the computation delay, it has been introduced a time of 0.005 s that is relatively small because of the massive computational power assumed to be available in the server. Simulations show that the delay introduced does not compromise the efficiency of the operations.

The second issue is represented by the possibility, in the real case, that some packets will never reach the destination. The protocol was naively thought to address all the computation to the Centralized Controller, and vehicles would have had just the duty to open the message downloaded and execute the acceleration printed inside of it. In order to increase the reliability of the control system, we have decided to provide a second modality for the execution of the protocol that trusts less the continuity of updates from the server. We must say that this will not wholly devaluate the presence of V2N communication since the Centralized Controller will always be in charge of managing the overall view of the environment and defining the connections between vehicles. It will just reduce the importance of the frequency of updates from the network since most of the essential data can be directly gathered on the vehicle. In the following, we will show the functional passages to implement the second part of the application.

3.3.1 Intra-vehicle Computation Implementation

Taking into consideration the equation (3.12), we can see that the only values that a vehicle cannot directly gain from its sensors are the spring constant, the damping coefficient and the relaxation length. In fact, LIDAR and RADAR sensors (with which every autonomous vehicle will be equipped [79]), are able to detect the relative position and position variation of vehicles that are in their line of sight. Moreover, on a highway, it can be considered easier to detect the line of sight vehicles because of the higher standardization of the environment, with very few elements other than vehicles. Because of the cooperation with artificial intelligence algorithms, together with the evolved technology that vehicles use to scan the environment, we can affirm that in the majority of cases a vehicle will be able to detect its neighboring cars, with their relative position and speed [80]. Hence, if the network can communicate to the parties which are their relations, and the vehicles are able to recognize their related by sensing the external environment, what is left is just the definition of l , k_n and b_n for each relation.

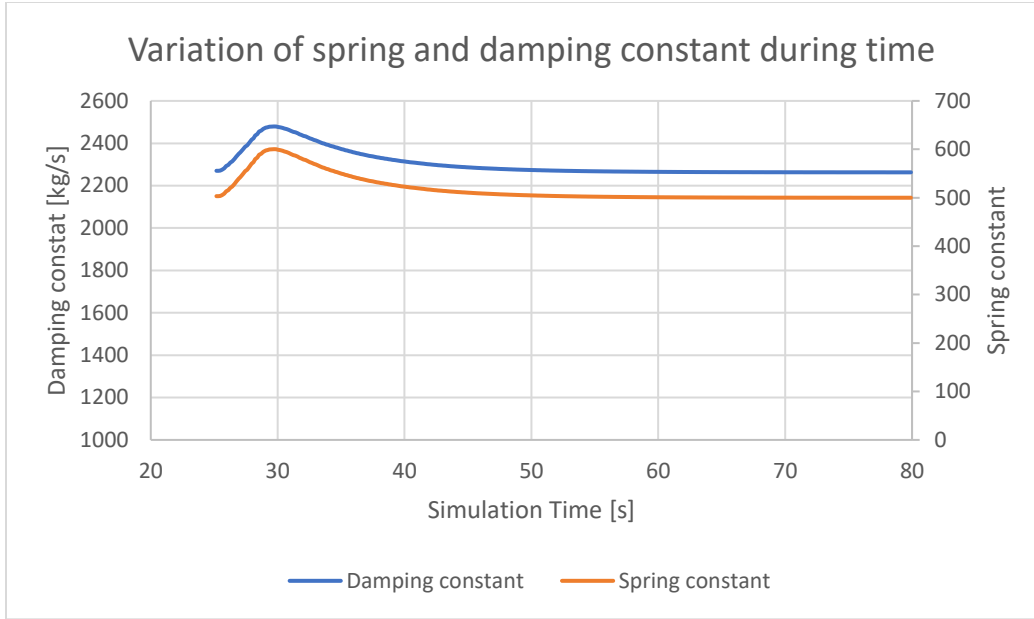

Figure 3-15 Variation of Spring Constant and Damping Coefficient

The relaxation length is decided online considering the necessities of both vehicles representing a connection. Once the value of τ is decided, it will remain constant for all the execution of the protocol. This means that in the case in which part of the computation is made on the vehicle, it is necessary to send just once the information related to this value, and the vehicle will use it until further notice.

For what regards the value of k_n and b_n , they are continuously recalculated on the server to provide the highest performance as possible. However, the highest value registered for the spring constant is only 15% higher than the minimum registered value while, for the damper coefficient, it is 10% higher, as shown in figure 3-15. The restricted difference makes it possible, for the case in which intra-vehicle analysis is exploited, to compute k_n and b_n for each connection on the server once, and to send the values to the vehicles that will use them during the totality of the protocol execution.

In this way, a second modality for the execution of the application has been given. It reduces the load on the network, and it increases the reliability of the overall system, because of the possibility to analyze data directly on the vehicle when no information is received from the network. The limitations of this implementation are the following:

- The vehicles still have the absolute necessity of an operative network that provides a centralized computing facility. This is needed in order to understand the relations between vehicles;
- The idea relies on the fact that a vehicle will recognize through scan sensors, which are the vehicles that the network decides it is related to. This can be direct when analyzing only forward and backward vehicles on the same lane, while more assistance may be necessary when the relationship is instituted between vehicles belonging to different lanes.

However, the possibility for the vehicles to elaborate in a decentralized way the situation with guidelines imported from a centralized managing location (e.g., server) is considered to be a valid point to be implemented in the system.

4 Simulation Models and Setup

The integration of communication technologies in the automotive environment will enable authorities, travelers, and operators to make coordinated and informed decisions. We have said that cellular networks are now seen as a valid option to provide a communication medium for next-generation vehicles. It is due to the large covered area, the excellent performances assured, and the higher penetration rate expected than DSRC. However, the introduction of this technology is a massive opera and, before having a high concentration of vehicles capable of communicating, some years are to be awaited. To justify the introduction of connectivity technology on vehicles, thus increasing the rate at which automakers will start to introduce these elements inside their vehicles, it is necessary to demonstrate the positive outcomes without relying on experiments made on real roads. Computer simulation is the only feasible solution to test connected vehicle applications. To this end, we can provide realistic results exploiting computer simulations that include communication models and models of vehicle mobility.

- Mobility simulator: a traffic generator is needed to monitor and analyze the reaction of vehicles inside the environment. It reproduces vehicles and their behavior during the simulation. Traffic simulators are also used standalone (without network involvement) to mime drivers' reactions to specific impulses. In our case, the Centralized Controller will control the dynamic variation of vehicle parameters (acceleration, direction), hence reducing the importance of the traffic models of the vehicle simulator.
- Network simulator: the network simulator should be directly connected with the traffic simulator. These are used to efficiently develop new applications for the connected environment, considering which is the performance of the network that is asked to move all the information. The network simulator is required to support protocols and manage the data exchanged between vehicles and, in our simulation, the controller.

For this thesis, we have chosen to use two open-source tools to validate the application: SUMO (Simulation of Urban Mobility), which is a microscopic road traffic simulator and OMNeT++ (Objective Modular Network Testbed in C++), a network simulator. Hence, we can build a realistic environment to test the model explained in chapter 3.

4.1 SUMO

Simulation of Urban Mobility (SUMO) is an open-source microscopic traffic simulator developed starting from 2001 by the Institute of Transportation Systems at the German Aerospace Center [81]. It models vehicle/driver behavior considering microscopic traffic parameters, such as speed, position, and orientation. Each vehicle inside the simulation will obey to its specific rules defined by the car following model and lane changing model used. It is built to allow the user to test different traffic control disposition, signal

timings, or alternative routes for vehicles, relying on the realistic reaction that drivers will have following the traffic model defined. It contains a *python* interface, TraCI (Traffic Control Interface) that is used to retrieve values of simulated objects and to manipulate their behavior "on-line". SUMO also comes with a series of tools, such as NETEDIT, that can be used to create a personal map.

Moreover, it is possible to import an existing urban configuration and modify it. Libraries, files related to the network disposition, route files, and configuration files are written using XML language. The XML files may be either handwritten or converted starting from graphic schemes generated with NETEDIT.

4.2 OMNeT++

OMNeT++ is an object-oriented modular discrete event network simulation framework. It has a generic architecture so that it can be used in various problem domains [82]:

- modeling of wired and wireless communication networks
- protocol modeling
- modeling of queueing networks
- modeling of multiprocessors and other distributed hardware systems
- validating of hardware architectures
- evaluating performance aspects of complex software systems
- in general, modeling and simulation of any system where the discrete event approach is suitable and can be conveniently mapped into entities communicating by exchanging messages.

OMNeT++ itself is not a simulator, but it provides infrastructure and tools for writing simulations. The strength of this software is the modularity that is offered: the primary component of any OMNeT++ architecture is called *simple module*. Modules are written in C++, and *simple modules* can be grouped into *compound modules*. When a network is built, it is called itself *compound module*. It is a discrete event simulator, meaning that state change occurs only at a discrete time step and each event takes zero time to be executed. All objects within the network are defined in the *Network Description (NED) File*. In this file, simple modules are connected or merged, creating the network topology.

OMNeT++ gives the possibility to rely on the existing framework and to build individual components and applications coding in the C++ language. It thus provides the user with existing tools to speed up the creation of the simulation, together with high flexibility and possibility to adapt to the specific case. For these reasons, this software has shown itself particularly suited for our case.

4.3 SimuLTE

SimuLTE is an innovative simulation tool enabling complex system-level performance-evaluation of LTE and LTE Advanced networks (3GPP Release 8 and beyond) for the OMNeT++ framework. SimuLTE is

written in C++ and is fully customizable with a simple pluggable interface. One can also develop new modules implementing new algorithms and protocols.

It represents an open-source project building on top of OMNeT++ and INET Framework. It models the data plane of the LTE/LTE-A Radio Access Network and Evolved Packet Core. The modules inside the simulation can communicate using either standard and user-defined messages. User equipment and mobile stations are implemented as compound modules. These can be connected between each other and with other nodes (e.g., routers) in order to compose networks. SimuLTE can also work with VEINS in order to simulate vehicular communication exploiting cellular communication networks.

4.4 VEINS

Vehicular in network Simulations (VEINS) is a framework for simulating vehicular networks, based on the road traffic simulator SUMO and that can be integrated into SimuLTE. The VEINS library contains a particular extension in the role of connecting the traffic and network simulators, where SUMO acts as a server and OMNeT++ as a client. The client will regularly ask the server about device mobility in order to update the disposition of devices inside the network accordingly.

Veins provides a comprehensive suite for connected vehicle models that can serve as a modular framework for simulating applications. Each model is contained in a OMNeT++ module, which can be instantiated in a running simulation to provide the required functionality. Veins instantiates one network node for each vehicle moving in SUMO. The *TraCIScenarioManager* module connects to the server (SUMO) and subscribes to events, e.g. creation and movements of vehicles. The *TraCIMobility* submodule is also essential in our case. It can be used to update the node's mobility information, retrieve values, and it includes functionalities to control the dynamic behavior of vehicles.

4.5 Simulation Setup

The simulation setup can be divided into two main parts. First, a definition of the road network and which elements are flowing through it is needed. This is done with the tools provided by SUMO. Then, the communication network that vehicles will exploit to exchange messages must be defined.

4.5.1 Traffic Setup

There are two different pieces of information needed in order to start a simulation with SUMO: **network topology** and **traffic pattern demand**. The network topology comprehends a network of roads, pedestrian ways, traffic lights and other means of moving cars, buses, trams, trucks and people. The traffic Pattern Demand instead comprises cars, buses, trams, trucks and people moving inside the network. The files containing the information are written in .xml format, respectively with the extension *.net.xml and *.rou.xml. These two components will be then unified inside a configuration file, with extension *.sumo.cfg.xml. It is also possible to include an additional file (*.add.xml) containing optional information

such as a background image to make the visualization clearer. In figure 4-1, an example of a configuration file encoded in XML is shown.

```
<configuration>
  <input>
    <net-file value="*.net.xml"/>
    <route-files value="*.rou.xml"/>
    <additional-files value="*.add.xml"/>
  </input>
</configuration>
```

Figure 4-1 Example of SUMO configuration file

4.5.1.1 The Network Topology:

A SUMO Network File (*.net.xml) accommodates the traffic-related part of the environment. It is constituted by the definition of roads, intersections, and traffic control components. A simple view of the SUMO network can be given by dividing it into two main participants: junctions and edges. In the SUMO context, junctions represent intersections, while edges denote roads or streets. It must be said that even if the XML format is human-readable, the network file is not generally supposed to be generated by hand. In fact, because of the complex articulations that usually we find on the road, together with the powerful tools available to create the network, human coding is helpful in very few cases. Two main ways of generating the network are considered:

- Acquiring a map from OpenStreetMaps;
- Utilization of graphical Tool to Create a Topology.

4.5.1.1.1 Acquiring a Map from OpenStreetMaps:

The acquisition of map data is useful whenever the task is to test the behavior of vehicles inside a chosen realistic environment. Recreating a real urban network by hand is highly time-expensive, and this tool provides to the user the possibility of directly selecting a portion of the real environment and exporting it in a format that can be understood by SUMO. Using a web browser and accessing the page www.openstreetmap.org, it is possible to select a portion of a map from the globe and export it. The result will be an XML file with extension *.osm.xml. It is then possible to convert this file in the .net.xml format by using SUMO tools.

4.5.1.1.2 Utilization of Graphical Tool to Create a Topology:

The control model shown in Chapter 3 offers its significant advantages at high speed. It is the condition in which a lack of sensibility of the driver with the vehicle, manifesting in erroneous output on the steering wheel, creates the most significant irregularities in the path of the vehicle. Secondly, it has been decided not to consider the possibility of vehicles entering or exiting from ramps. Last, in order to facilitate the first

analysis, it has been decided to consider only a straight highway with no turns. On the highway, turns generally have a large radius, and this gave us the possibility to analyze a more relaxed environment (straight road) without loss of pragmatism. Since it is also crucial to analyze lane changing effects of transition, multiple lanes are needed. All these considerations are here resumed:

- High-speed environment;
- No ramps;
- No turns;
- Multiple lanes.

The network resulting from these considerations is of straightforward derivation. Hence, searching on the map for the right portion respecting all the requisites may consume more time than manually create it. In order to build the road network, it is possible to use the software NETEDIT. NETEDIT is a visual network editor that can be used to build a network from scratch or to modify an existing network. Being also user-friendly, it has become the main alternative to build the environment needed for the simulation. The network can be visually built, then NETEDIT will convert the network into a .net.xml file that can be used by SUMO. For our simulations, the road network will be constituted by a straight highway with three lanes and no secondary roads or ramps converging in it. The total length is 6 km.

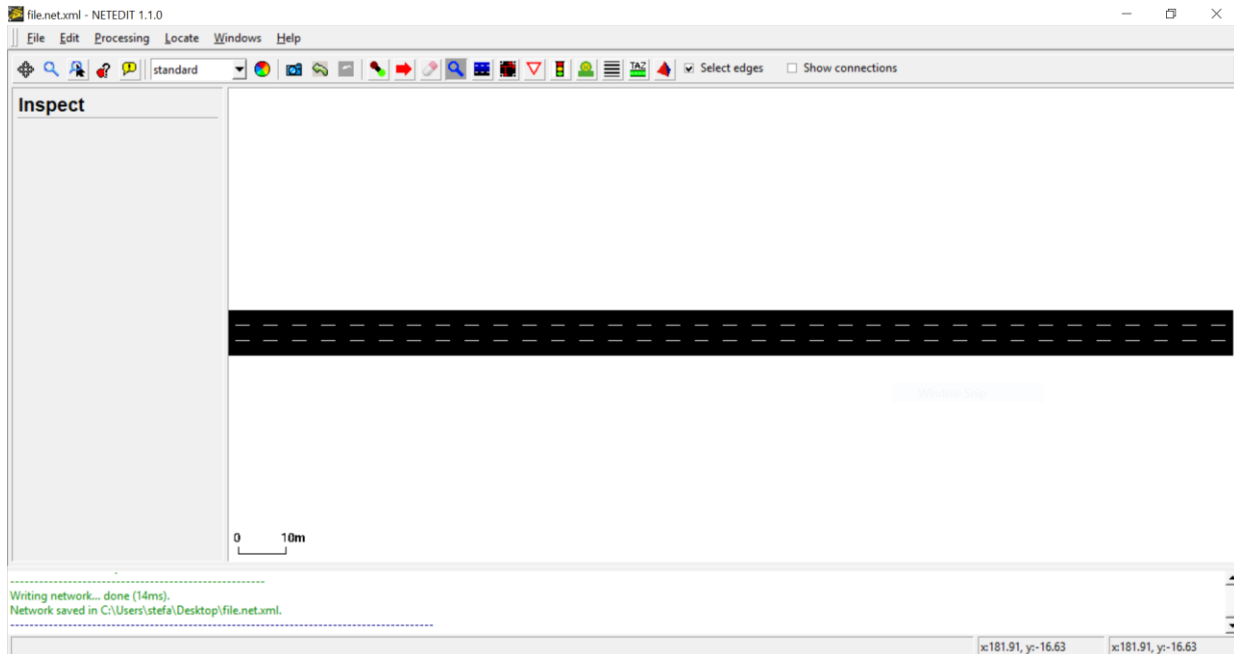

Figure 4-2 Example of an environment that can be created using NETEDIT

4.5.1.2 Traffic Pattern Demand:

After the network has been generated, it can be opened in the SUMO interface, but no cars are going to drive around in it. It is still needed to define the proprieties needed by the vehicles and how they will move

in the network topology. This component of the simulation is called traffic demand. The traffic demand is built defining the types of vehicles flowing inside the simulation and their routes. The route contains all edges vehicles will touch during the simulation, from their origin to their destination. SUMO gives the possibility to define the type of vehicles, dimensions of vehicles, acceleration and deceleration capabilities, driver imperfection, and other proprieties that can be of interest to the entities moving inside the environment. Then, it will be decided how the vehicles enter and exit the simulation through the definition of vehicle routes.

4.5.1.2.1 Vehicle Definition:

In SUMO, different vehicle types can be defined using the `vType`-element. Then, it is possible to create a vehicle inside the simulation recalling the type, as shown in figure 4-3.

```
<routes>
  <vType id="type1" accel="1.8" decel="4.5" length="5" sigma="0.0" tau="0.1"
  maxSpeed="70" />
  <vehicle id="veh1" type="type1" depart="0">
    <route edges="edge1 edge2 edge3"/>
  </vehicle>
</routes>
```

Figure 4-3 Example of `.rou.xml` routes file

The definition of types includes physical parameters, as the length of the vehicle, its color, or its maximum velocity, and also parameters of interest for the car following model. In our case, we have chosen to use the default Krauss car following model. Even if, in the majority of simulations, the traffic model is used to simulate a realistic behavior of driver subjected to a specific input on the road, for this simulation it is assumed a penetration rate of 100% of autonomous and connected vehicles that are centrally controlled. For this reason, the importance given to the car following model is reduced, since it will be the algorithm of the Centralized Controller to decide the dynamic changes in acceleration and directions of the vehicles. Two parameters of the Krauss car following model are of great importance also in our case:

- Driver imperfection: the driver imperfection is a number between 0 and 1, where 0 defines the perfect driver. Driving is a complex task for the human being, and not always it is understood by the driver how he should react to a stimulus.
- Moreover, even understanding precisely the situation, humans have an inevitable imprecision in executing commands. The driver will thus control the vehicle in a non-perfect way. Simulating a wholly automated environment, we have decided to set this value to 0. Hence, vehicles will execute the acceleration given by the Centralized Controller with absolute perfection.
- Time Ahead: most car following models define, as the main parameter influencing the driver behavior, the time distance from the following vehicle. The time gap is set to decide if the vehicle

is more likely to accelerate (e.g., when it is positioned at a relatively large distance from the following vehicle) or decelerate. In practice, if two vehicles get too near to each other, they will act to increase their distance until the time ahead desired is acquired, simulating the human actions on the controls. This is the concept of the car following model: to simulate driver reactions.

However, in this simulation, the acceleration/deceleration should be entirely in the hands of the Centralized Controller. The possibility of drivers automatically braking due to the car following model is not acceptable, because it will compromise the validity of results for the control mechanism. For autonomous vehicles, it has been decided a time ahead of 0.8 s. The vehicle transitioning has the same value before the transition, and time ahead equal to 2.0 s after the transition, increased due to human reaction time. Since the application will take control to respect these gaps, it has been decided to set the default time ahead value of the car following model equal to 0.1 s. In other terms, since SUMO does not directly provide the possibility to disengage this parameter, we have chosen a sufficiently low time ahead to avoid the interaction of the Krauss model with our control mechanism.

Figure 4-3 shows other parameters that have been defined. The length has been chosen equal to 5.00 m, which was also the default value for the length-element. The maximum speed that a vehicle may reach is also defined within the maxSpeed-element. For our simulations, all the vehicles inside the environment will have the characteristics shown in figure 4-3.

4.5.1.2.2 Route Definition:

In the network topology defined for this experiment, the path followed by the vehicles is directly understood. There is only one direction to be followed, an entry junction and an exit junction. The route is thus already decided. What we can vary is the way vehicles enter the simulation.

The application aims to create a certain amount of free space around a vehicle in which the transition from autonomous to manual modes is occurring. For this reason, higher is the density of vehicles around the one transitioning, more difficult it is for the Centralized Controller to allocate free space in that position. Moreover, when we must increase the distance between two vehicles, speed difference is necessary. If, when the simulation starts, vehicles already have a certain speed difference, it may be exploited to increase the free space around the vehicle transitioning. Hence, the case in which all vehicles are proceeding with the same speed is seen as the worst-case scenario since speed difference must be increased starting from zero. Two main features are interesting for the topology of the routes:

- High-density traffic;
- All lanes with the same average speed.

A total number of 22 vehicles will enter the simulation. The condition in which all vehicles are proceeding at high speed (30 m/s) will be analyzed. They will enter at 0.8 s gap from the vehicle in front of them. Once

the application realizes that all vehicles are inside the simulation and in realistic relative positions between each other, the environment definition will be considered complete, and the simulation of the transition can be started. The disposition of the vehicles when the simulation starts is shown in figure 4-4. The vehicle that will be subjected to transition is vehicle 10. When the transition starts, the Centralized Controller will behave as shown in chapter 3. All vehicles will be redirected in order to converge toward the ideal disposition. The results are shown in chapter 5.



Figure 4-4 Vehicle disposition before of transition detection

4.5.2 Communication Network Setup

We have shown the functional passages between controller and vehicles. Information exchange is necessary, and the cellular communication network will enable it. The network will be developed relying on the SimuLTE framework, which is built on top of OMNeT++. Three main components constitute the OMNeT++ configuration:

- Description File (.ned): it defines components and how to assemble them into larger units like networks.
- Initialization File (.ini): the initialization file is used to define the parameters of the simulation and to launch the desired topology of network and traffic demand.
- Source Code (.cc): It defines all the functionalities of the module. It is programmed in C++ language.

4.5.2.1 Description File: Network Definition

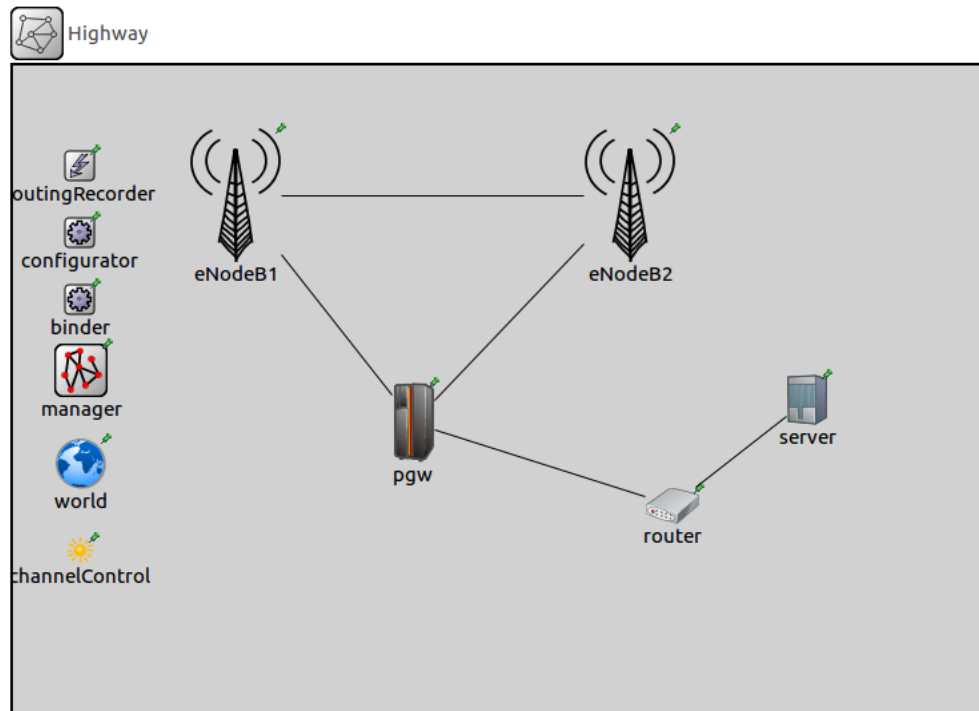

Figure 4-5 Cellular Network definition

The SimuLTE package is already embedded with a series of built environments that can be used for simulations. In our experiment, it has been decided to use as a starting point the network shown in figure 4-5, representing an LTE network with a simplified EPC. In the next, a description of the main components will be given.

The X2 interface between eNodeB1 and eNodeB2 allows communication between them in order to enable interference coordination protocols or handover. The nodes also have a module implementing GTP, enabling tunneled communication between base stations and PGW. The PGW is the entry/exit of the LTE network, and it routes data from the radio technology to the rest of the internet. The binder module is responsible for storing network-wise information, and all the entities of the LTE network can access this information directly recalling it.

The configurator module comprehends an INET module used to assign IP addresses. The configurator works with all the elements present inside the simulation when it starts, while it does not take into consideration the vehicles entering the environment during runtime.

As said, the interaction with the urban mobility within VEINS is provided by SUMO. The responsibility of interacting with SUMO is addressed to the TraCI interface. In any network definition, the *TraCIScenarioManager* module must be included. This module obtains information about the movements

of the vehicles in the road traffic scenario and updates the mobility information in the OMNeT++ environment.

4.5.2.2 Description File: Car Module

Each vehicle entering the SUMO simulation must be created inside OMNeT++ with communication capabilities. The high-level idea is to have the same type of equipment of a legacy UE, but with the mobility features needed for vehicles. The NIC is needed to provide communication capabilities to the vehicle. The legacy UE module also contains the INET mobility module. However, it is not thought to model the more articulated mobility of vehicles, and it does not provide all the functions needed for the connected and automated vehicle simulation. For this reason, the *vehicularMobility* module has been added.

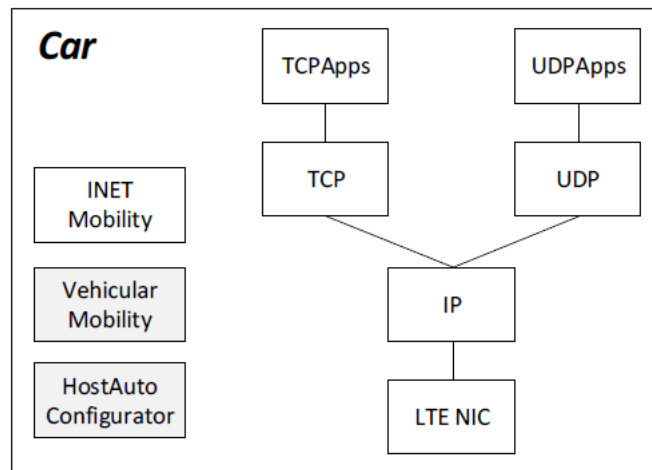

Figure 4-6 Car module used in the simulation

When a new vehicle is created, it needs an IP address in order to communicate. In the previous subchapter, we have described how the *configurator* takes the role of assigning the IP addresses only at the beginning of the simulation. Hence, the car module is endowed with the *HostAutoConfigurator* module, in charge of assigning IP addresses for entities entering the simulation when it has already started. The module also contains both TCP and UDP application and transport layer submodules. These blocks will be the ones in which the application written for the vehicle side will be inserted.

Once the vehicle is created, it will measure the power received from each eNBs inside the environment and will choose to attach to the one with the most significant power received. The handover will be possible if needed.

4.5.2.3 Source Code: Centralized Controller and Vehicle Application

OMNeT++ provides the possibility to code source codes defining the behavior of the modules personally. It has been explained which model will be used in the automated and connected environment in order to execute a cooperative reaction to the transition. The mechanism of sensing, sending, analyzing information,

and executing control commands will be enabled by two different entities: vehicles and the Centralized Controller. We have shown the functional processes associated with both parts in Chapter 3.2 and Chapter 3.3. The concepts there explained have now the necessity to be coded into algorithms that the software can understand. Hence, two applications will be written: one common to all the vehicles, the other will be instantiated in the server, and it will act as Centralized Controller. Both have been written in the language that the software is able to read: C++. Hence, the same ideas that have been derived in Chapter 3 can be simulated.

4.5.2.4 Initialization File:

In this section, we will show the few relevant parameters to be settled in the initialization file of OMNeT++ in order to perform a simulation that integrates SimuLTE, Veins and the specific traffic parameters of the road network.

In the initialization file, we have to assign which network will be tested within the *network* parameter. It is done as shown in figure 4-7 (line 1). The right side of the equation represents the path to the description file analyzed in chapter 4.5.2.1. The configuration of the network includes a binder and a manager module. The second one needs to be informed about the type of module that vehicles will assume when they enter the simulation. The module used in this case is the one described in chapter 4.5.2.2, and line 3 of figure 4-7 represents how the manager is informed. Moreover, it has not been said yet how to assign the traffic pattern demand created with SUMO tools to the OMNeT++ environment. The *launchConfig* parameter does it. An XML document is given on the right side of the assignment. This file, **.launchd.xml*, contains the **net.xml*, **rou.xml* and **sumo.cfg* files (figure 4-8). In this way, once the connection between OMNeT++ and SUMO is made, the desired configuration can be launched by the software. Line 7 and 8 show how the behavior of the modules is defined. The source codes for both vehicle and server are assigned. The behavior of the other components of the network is already implemented, and we have no need to vary their parameters.

```
1 network = lte.simulations.Network
2 ...
3 *.manager.moduleType = "lte.corenetwork.nodes.cars.Car"
4 *.manager.moduleName = "car"
5 *.manager.launchConfig = xmldoc("*.launchd.xml")
6 ...
7 *.car[*].udpApp[0].typename = "CarApp"
8 *.server.udpApp[0].typename = "CentralizedController"
```

Figure 4-7 Manager assignments within the initialization file

```
<launch>  
  <copy file = "*.net.xml"/>  
  <copy file = "*.rou.xml"/>  
  <copy file = "*.sumo.cfg" type = "config" />  
</launch>
```

Figure 4-8 Example of .launchd.xml file

5 Simulation Results

This chapter will show the performance of the model described in chapter 3 that has been applied to the simulated environment shown in chapter 4.

5.1 Flexibility of the System when the Time Buffer is Varied

It is likely in the future that vehicles will be able to detect transition with a certain margin. The car relies on different sensors and communication modes to pursue autonomous driving, and it is improbable that all the autonomous driving resources will fail at the same moment. What is more likely is that, because of the failure of a single sensor, the vehicle will feel less reliable, and it will thus ask the driver to regain control. In this way, the car will provide a specific time for the driver to prepare. We can exploit this interval to react in advance.

The controller primary aims to provide safety for the vehicle transitioning and the ones around in the area. The human driver gaining control after the transition reduces the overall safety, and we want to allocate free space around him to reduce the risk. Figure 5-1 represents the area required. The controller aims to bring all the vehicles outside of the area needed. Safety is achieved when all the space is cleared before the end of the transition.

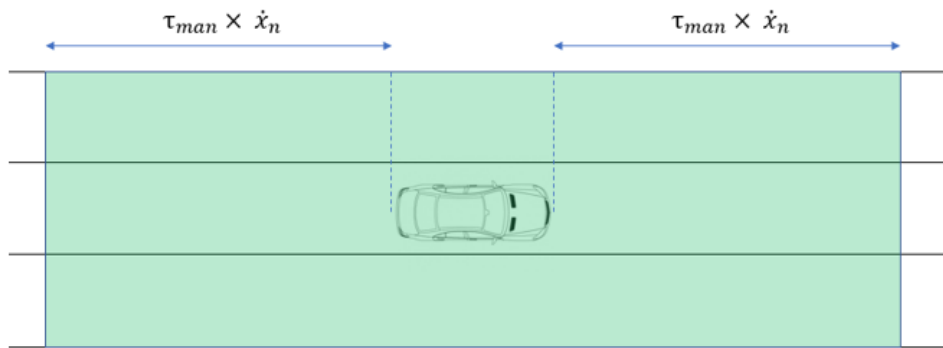

Figure 5-1 Area required by vehicle transitioning

When the simulation starts, 22 vehicles will be flowing in the highway in high-density conditions. Vehicles will keep a constant time ahead equal to 0.8 s from the following vehicle. All vehicles will move at 30 m/s, and this condition will be unchanged until the transition is detected. The situation is represented in figure 5-2 a). Vehicles will keep a longitudinal distance equal to $\tau_{man} * \dot{x}_n$, and all the lanes will be occupied by vehicles. When the transition is detected, the requirements of the vehicle transitioning will change, as shown in figure 5-2 b). Hence, the controller will start to send indications to the group of vehicles in order to reach

the disposition visible in figure 5-3 c). If the latter is reached before the end of the transition interval, the vehicles will be considered safe. When it is not possible, the risk will not be considered null.

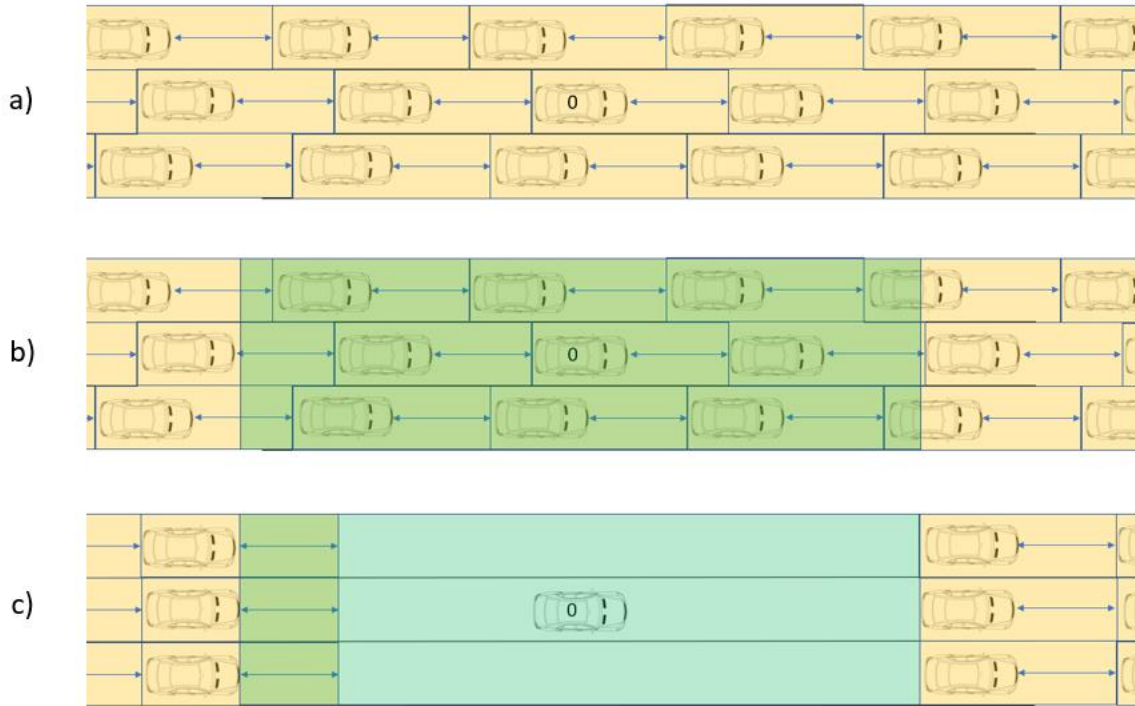

Figure 5-2 Initial disposition a), risk detection b), final disposition c) in the simulated environment

Figure 5-1 also shows that the requirements of the vehicle transitioning are the same among the three lanes. Hence, we can study the evolution during transition exploiting 2D graphs.

An example of the behavior of vehicles directed by the controller is shown in figure 5-3. It represents the variation in time of the relative longitudinal position of all vehicles. The relative position is evaluated comparing the position of each vehicle to the position of the vehicle transitioning. The rectangle in figure 5-3 appears when the transition is finished. The lines representing surrounding vehicles should not be inside the area for safety reasons.

The transition is detected at $t=7$ s. Starting from this moment, the controller takes the role of redirecting all the vehicles. The routing is visibly smooth, and vehicles align themselves at a larger distance than the one needed by the vehicle transitioning. Hence, safety conditions are successfully reached.

The speed profile within time is shown in figure 5-4. All vehicles enter the simulation with a steady-state 30 m/s motion. The traffic condition is stable until the transition is detected. After the transition starts, we see that a part of the vehicles starts to accelerate, others to decelerate. When a vehicle is freeing space by accelerating, it encounters more difficulties due to different reasons:

- Firstly, increasing the speed also the space requirements of each vehicle is augmented ($s = \tau * \dot{x}$). Vehicles must respect their own requirements before achieving the needs of the one transitioning. Hence, acceleration happens to be limited.
- Then, the acceleration performance of a passenger vehicle is usually lower than the deceleration. Hence, the maximum deceleration is higher than the maximum acceleration.
- Last, roads usually have a speed limit that cannot be overcome. Once it is reached, the acceleration must be set to $0 \frac{m}{s^2}$.

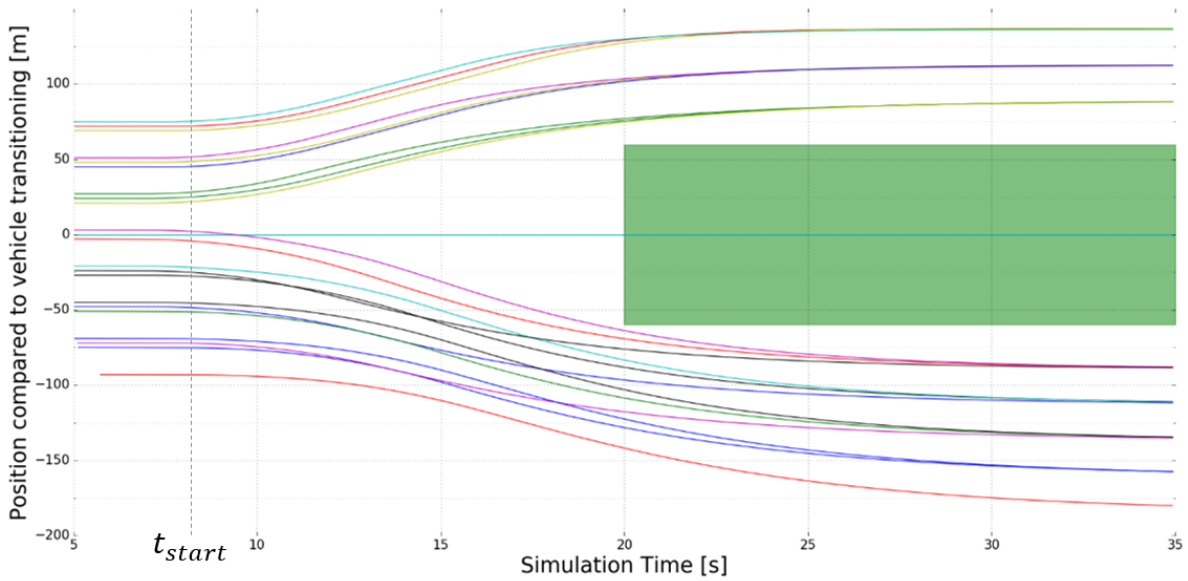

Figure 5-3 Variation of relative longitudinal distance within the simulation time

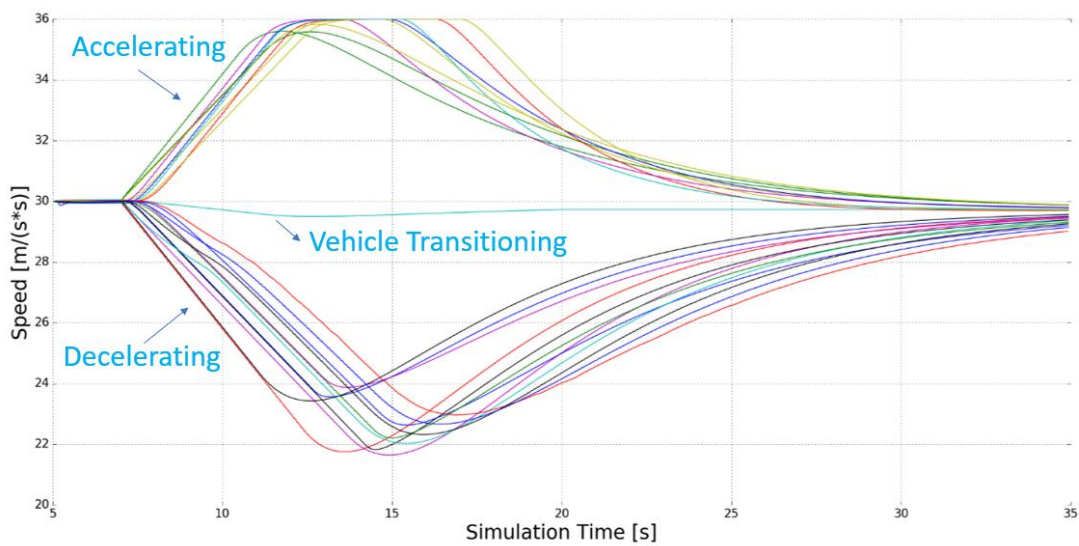

Figure 5-4 Variation of speed vs. simulation time

Figure 5-4 shows how the speed of vehicles becomes constant once the speed limit (36 m/s) is reached. In order to balance the disparities between vehicles that accelerate and decelerate, the motion of the vehicle transitioning will be exploited. In figure 5-4, the speed profile which slightly fluctuates under 30 m/s belongs to the vehicle transitioning. During the transition, the vehicle will still be in autonomous mode, and the controller will be able to manage its movements. The vehicle will be controlled until the end of the transition. Then, it will be in the hands of the human driver.

At the end of the transition, all the vehicles will drive again at the same speed. The ideal final speed is supposed to be 30 m/s, equal to the starting speed. In the case in which acceleration and deceleration sides are totally symmetric, the vehicle transitioning will be subjected to acceleration equal to 0. Hence, its speed will be unchanged.

We are conscious that, in the future, there will be methods to foresee the time buffer. However, it is not possible to pick a single value in advance. Hence, the performances of the protocol have been analyzed with different time buffers spreading from 0 s to 20 s.

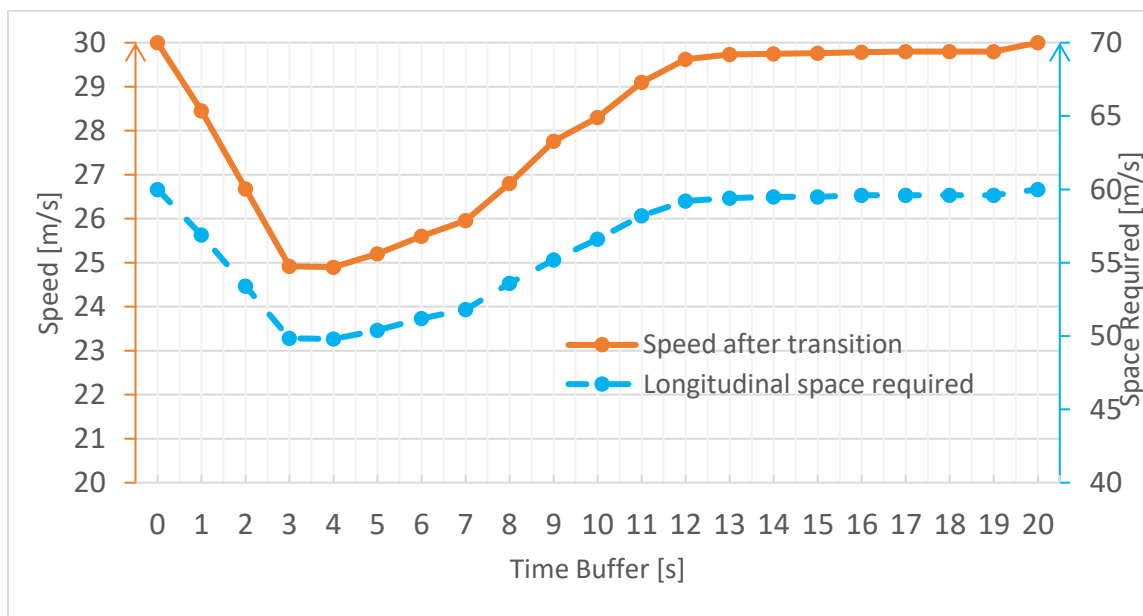

Figure 5-5 Final speed of vehicle transitioning with different time buffers

Figure 5-5 shows the final speed of the vehicle transitioning with different time buffers. When the Time Buffer is sufficiently large (> 13 s), the speed variation is low as expected. Speed difference and acceleration are not significant enough to create a strong asymmetry between acceleration and deceleration sides. Since we have no asymmetry, the vehicle transitioning (positioned in the middle) has no reason to change its speed.

The situation varies when we decrease the time buffer under 13 s. An asymmetry will arise for the considerations stated previously. The vehicle in transition will exploit the time buffer to decelerate. In this

way, it will aid the vehicles that are accelerating, increasing the speed difference with them. For the SMD system, the asymmetry is felt like a resistance caused by vehicles positioned in front. This resistance represents a higher compression of the spring in front than the one behind. Hence, the vehicle will be pushed back.

When the time buffer becomes lower than 3 s, the final speed starts to increase again. Speed variation of the vehicle transitioning can only be achieved within the time buffer since the vehicle becomes human-driven at the end of it. Time buffer < 3 s gives no time to the vehicle in transition to change its speed significantly.

The reduction of speed of the vehicle transitioning has two main effects:

- Balancing the asymmetries for vehicles accelerating or decelerating;
- Reduction of the longitudinal space needed by the vehicle transitioning.

We have already discussed the former. For what regards the latter, we may say that a reduction of the total amount of required space makes the job easier for the controller. In fact, it must allocate less space. Figure 5-5 also shows the value for the total amount of space needed in both forward and rearward directions. It is directly calculated from the final speed and reaction time ($\tau_{man} * \dot{x}_n$). Reducing the speed, we reduce the space required, and it will be easier to perform the operations.

5.2 Evaluation of Safety and Comfort

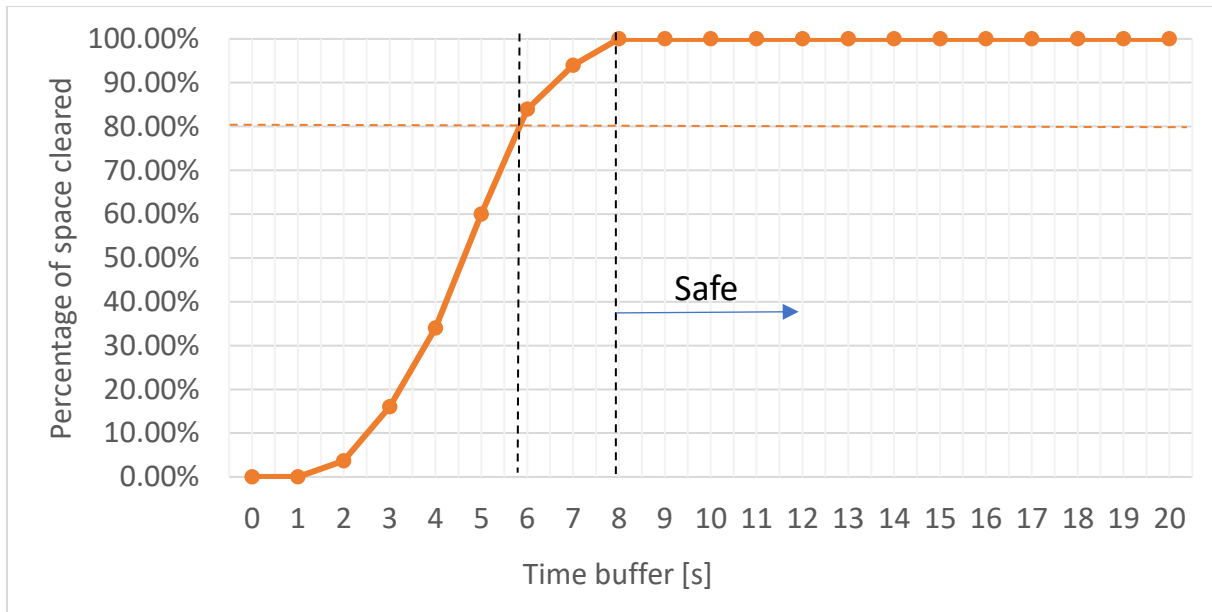

Figure 5-6 Percentage of required space that is cleared at the end of the time buffer

The primary purpose of the controller is safety. Safety is achieved when the total space required by the vehicle transitioning is allocated within the time buffer. Figure 5-6 shows the percentage of space cleared before the end of the transition for time buffers spreading from 0 s to 20 s. When the time buffer is relatively large, it is easy to allocate the space. We see that for time buffer higher than 8 s, the area is cleared in its totality. When we decrease the time available, the performance is gradually reduced. A time buffer equal to 6 s is sufficient to free the 80% of the total length. When the time buffer is lower than 3 s, we can say that no positive outcomes can be extracted from the scenario tested.

The following considerations can be driven:

- Safe conditions can be achieved only when the time buffer is higher than 8 s;
- Acceptable condition is reached when the time buffer is higher than 6 s, since vehicles will be positioned in the alignment zone at the end of the transition;
- No positive outcomes are manifested when the time buffer is lower than 3 s.

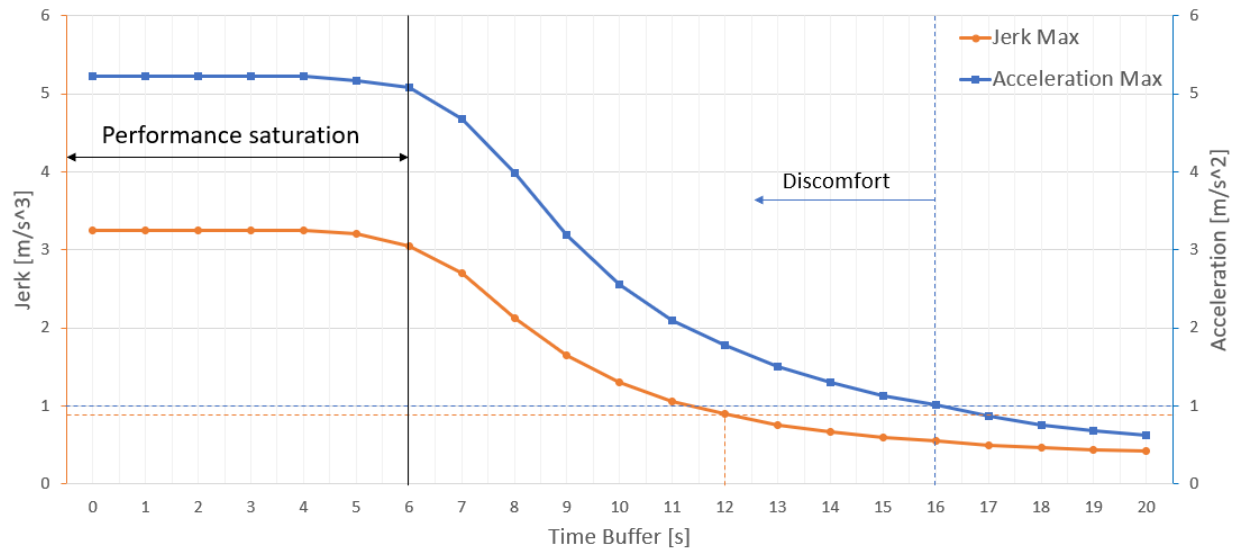

Figure 5-7 Maximum Acceleration and Jerk registered with different time buffers

The controller is also able to reach a safe disposition efficiently. Hence, a second parameterization which considers the comfortability of vehicles' passengers is introduced. Studies show that acceleration and its time derivative, jerk, significantly affect the comfort of the ride. A threshold exists under which the ride can be considered comfortable. The boundary has been set to $1 \frac{m}{s^2}$ for the acceleration and $0.9 \frac{m}{s^3}$ for what regards the jerk [83]. The maximum and average values of acceleration and jerk are used to evaluate the comfortability of the passengers within the protocol execution.

Figure 5-7 represents the maximum values registered for acceleration and jerk by varying the time buffer. It is visible that the controller increments the acceleration based on the time buffer. When we reduce the

interval, higher acceleration is needed to free the same quantity of space in time. When the time buffer is increased, we can successfully free the area with relaxed movements. Relaxed movements indicate the comfortability of the drivers. The protocol can be considered comfortable when equations (5.1) and (5.2) are both satisfied.

$$\ddot{x}_{max} < 1 \frac{m}{s^2} \quad (5.1)$$

$$\dddot{x}_{max} < 0.9 \frac{m}{s^3} \quad (5.2)$$

In figure 5-7, it is visible that it happens when the time buffer is larger than 16 s. It is also seen that the profiles for acceleration and jerk are converging when the time buffer reaches 20 s. The acceleration quadratically increases while the time buffer is reduced.

The behavior is respected until the maximum acceleration that can be actuated by the vehicles is reached. Then, the controller would compute an acceleration/deceleration that the vehicles are not able to perform. It can be said that the point of saturation for the performance of the controller has been reached. We see that the saturation point for the controller performance is reached with the same time buffer that provides acceptable results for safety: 6 s.

The controller demonstrates to be efficient when a time buffer is higher than 6 s. When it is lower, it may be appropriate to develop alternative methods to transition. It is consistent in the results that if the time buffer is lower than 3 s, the safety of the high-density scenario is not improved at all. However, we believe that vehicles will be able to foresee transition with a more significant interval. The comfort for vehicle passengers increases with the time buffer. Time buffer equal to 16 s is the boundary to satisfy both safety and comfortability requirements. Time buffer equal to 8 s, instead, is the boundary for safe operations. Hence, the simulations with 16 s and 8 s time buffer for the transition will be further discussed.

5.3 Time Buffer equal to 16 s: Safe and Comfortable Operation

Figures 5-8, 5-9, and 5-10 respectively show position, speed, and acceleration profiles for all vehicles during simulation time, when the time buffer is equal to 8 s. The transition is detected at $t=7s$ and the time buffer is 16 s long. Thus, the transition is completed at $t=23 s$. At the end of the transition, no vehicle is inside the area allocated: hence, safety requirements are respected. In figure 5-8, it is seen that no line crosses the area of the rectangle.

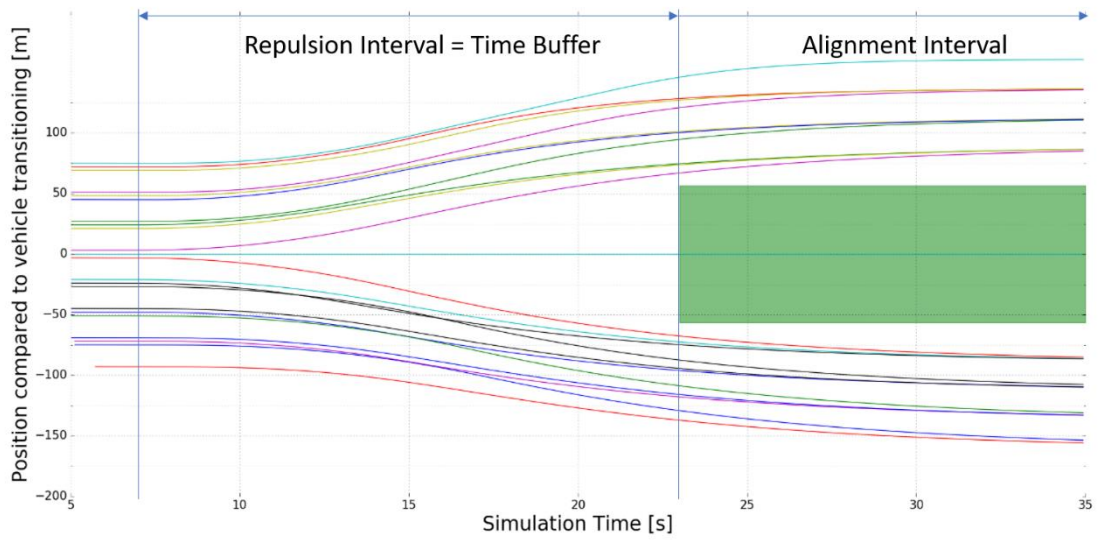

Figure 5-8 Variation of relative longitudinal distance within simulation time, time buffer equal to 16 s

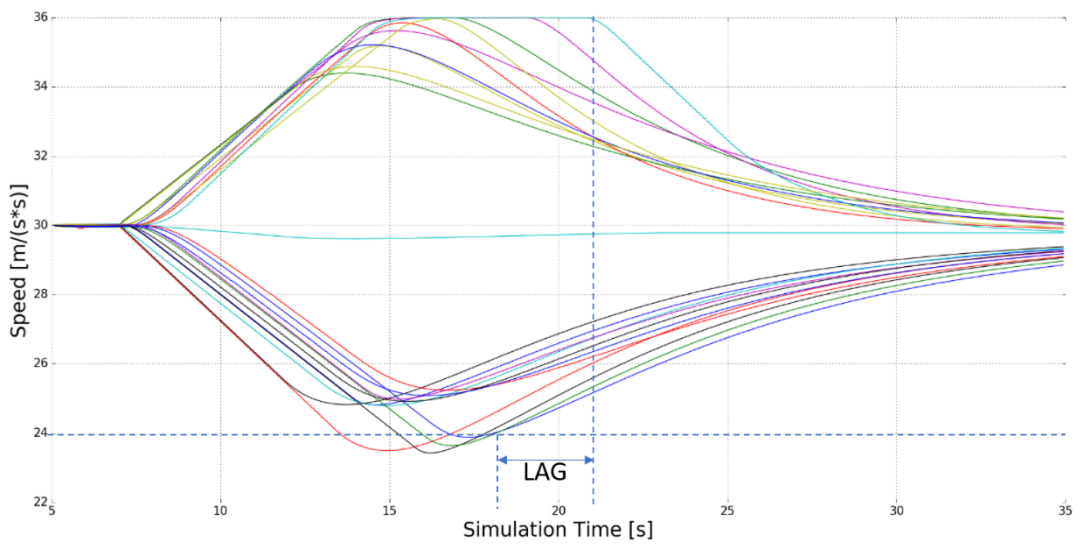

Figure 5-9 Variation of speed within simulation time, time buffer equal to 16 s

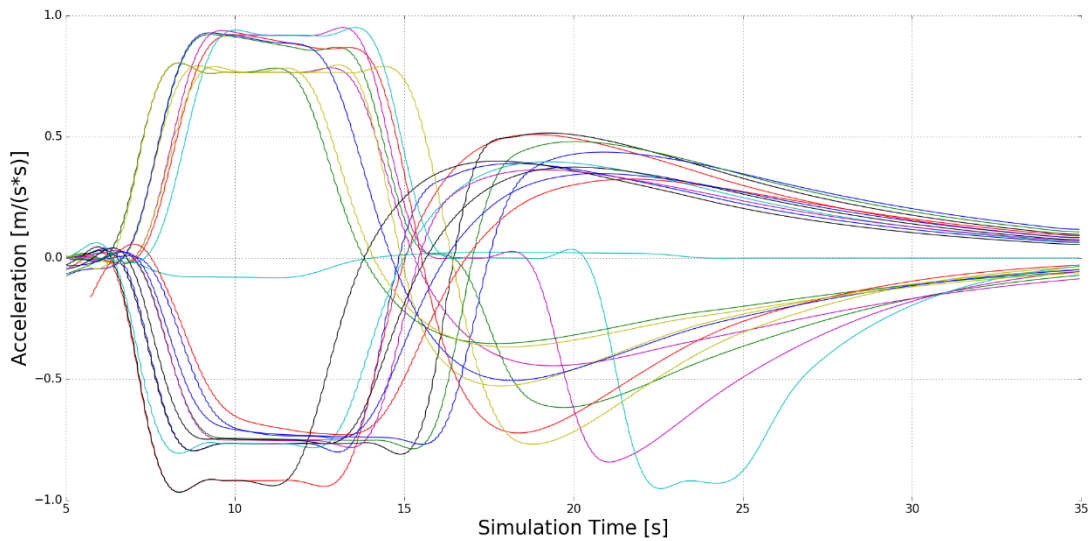

Figure 5-10 Acceleration vs. simulation time, time buffer equal to 16 s

Let us analyze the behavior represented by the figures. Vehicles will increase speed difference (both positively and negatively) in order to augment their distance from the vehicle transitioning. The region in which speed difference is relatively high is intended as the repulsion interval. In this case, the entire length of the time buffer can be seen as the repulsion interval. Once, the majority of space is allocated, the vehicle will start to adjust their speed to reach again the initial one (around 30 m/s). When it happens, vehicles are in the alignment interval, converging toward the ideal disposition.

The behavior of the vehicles follows the same as a SMD system, with few limitations:

- Figure 5-9 shows that some vehicles are reaching 36 m/s, the maximum speed allowed on the highway. Hence, the motion is modified by the rules existing on the road.
- The acceleration is also limited. Figure 5-10 shows that the profile of the acceleration is not the one expected by a spring mass-damper system. In part, the acceleration is nulled because the speed limit has been reached. On the other hand, the acceleration is also limited to avoid a magnitude more extensive than the one needed to achieve safety requirements.

Since Veins does not support commands for acceleration retrieval, the values have been calculated differentiating the speed of vehicles in time. Moreover, because of the discrete proprieties of OMNeT++ simulations, substantial irregularities were visible in the results. Figure 5-10 shows the filtered results for acceleration.

Furthermore, it is visible from figure 5-9 that a certain retard exists for vehicles that have accelerated in the first phase, indicated in the figure as lag. The time instants identifying the lag consider the moment in which all vehicles are achieving a speed difference lower than 6 m/s compared to the initial speed. It shows that

vehicles that have decelerated in the first phase are called back faster. It demonstrates the higher feasibility in freeing space by decelerating and justifies the reduction of speed of the vehicle in transition, shown in figure 5-5.

For what regards the comfortability requirements, we have already seen that the 16 s time buffer keeps the maximum value for jerk and acceleration always in the range of comfort. Figure 5-10 shows the acceleration profile. $1 \frac{m}{s^2}$ is the absolute limit for comfortability, and all vehicles always stay within $-1 \frac{m}{s^2}$ and $1 \frac{m}{s^2}$. Table 9 represents the average and maximum values of acceleration and jerk registered. It concerns all the vehicles, where the ID is the same as shown in figure 4-4. The maximum acceleration registered is $0.97 \frac{m}{s^2}$, while maximum jerk stops at $0.49 \frac{m}{s^3}$. The average values are substantially lower than the maximum retrieved.

Table 9 Comfortability evaluation parameters with time buffer equal to 16 s

Vehicle ID	$\ddot{x}_{max} [\frac{m}{s^2}]$	$\ddot{\ddot{x}}_{max} [\frac{m}{s^3}]$	$\bar{\ddot{x}} [\frac{m}{s^2}]$	$\bar{\ddot{\ddot{x}}} [\frac{m}{s^3}]$
10	0.08	0.04	0.02	0.01
3	0.96	0.38	0.47	0.12
8	0.81	0.38	0.34	0.08
9	0.8	0.36	0.41	0.08
5	0.94	0.38	0.41	0.09
7	0.8	0.36	0.33	0.07
13	0.96	0.45	0.38	0.09
18	0.75	0.27	0.34	0.07
0	0.97	0.41	0.48	0.13
11	0.97	0.44	0.47	0.09
20	0.78	0.41	0.41	0.07
4	0.8	0.45	0.4	0.09
21	0.74	0.27	0.33	0.07
12	0.81	0.38	0.38	0.08
2	0.8	0.49	0.47	0.1
19	0.79	0.39	0.35	0.07
15	0.77	0.32	0.36	0.07
6	0.94	0.37	0.45	0.1
1	0.94	0.49	0.46	0.11

14	0.82	0.52	0.46	0.09
16	0.81	0.43	0.37	0.08

5.4 Time Buffer equal to 8 s: Safe Operation

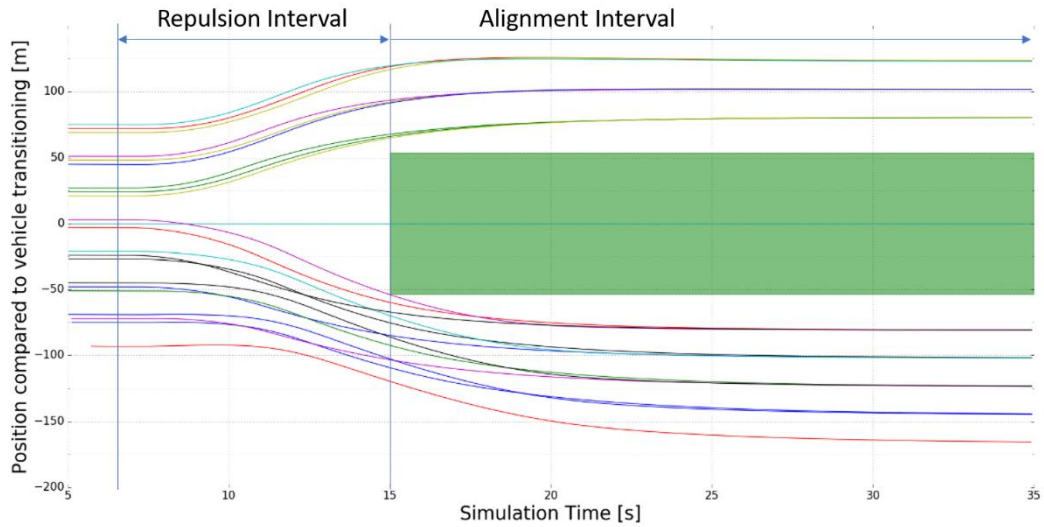

Figure 5-11 Variation of relative longitudinal distance within simulation time, time buffer equal to 8 s

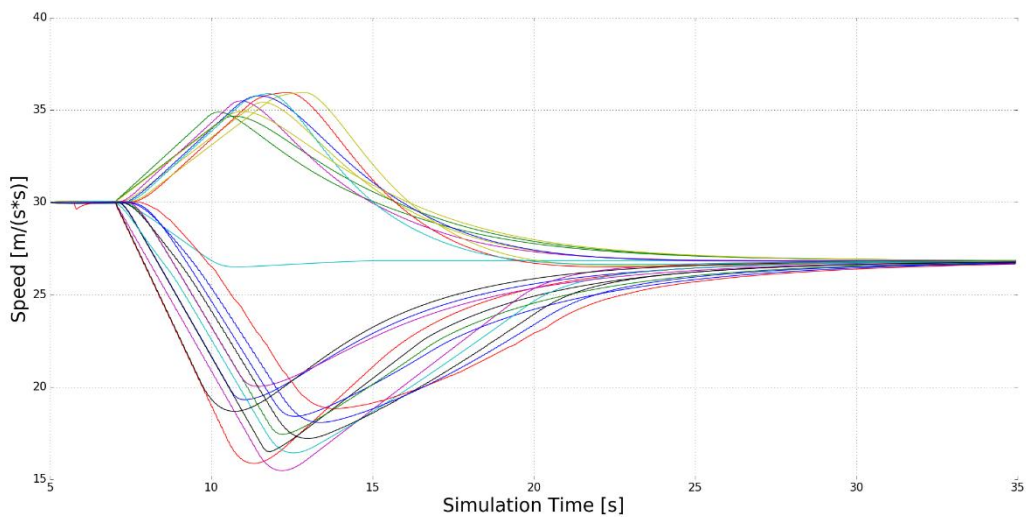

Figure 5-12 Variation of speed within simulation time, time buffer equal to 8 s

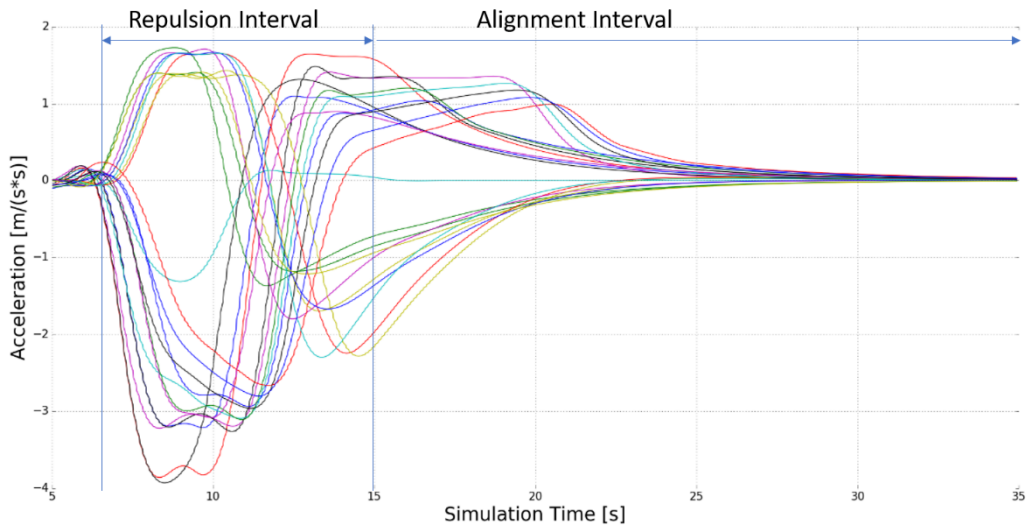

Figure 5-13 Acceleration vs. simulation time, time buffer equal to 8 s

Figures 5-11, 5-12 and 5-13 show respectively position, speed, and acceleration profiles for all vehicles during simulation time. The time buffer is now set equal to 8 s. The transition still begins at $t = 7$ s, and it ends at 15 s.

From figure 5-11, we see that the safety requirements are also respected in this scenario. However, the movements result harsher. The acceleration/deceleration of all vehicles is more drastic than before since the same quantity of space must be reallocated in a lower amount of time.

In the graph representing the speed profile (figure 5-12), the deceleration of the vehicle transitioning becomes more evident. As said, when the controller senses an asymmetry in acceleration and deceleration capabilities, it sends indications to the vehicle in the transition to compensate. In the scenario with time buffer equal to 16 s, the maximum acceleration was fluctuating around $1 \frac{m}{s^2}$, while the maximum deceleration was stable near to $-1 \frac{m}{s^2}$. Hence, the behavior was considered symmetric. In the actual case (figure 5-13), the maximum acceleration of vehicles is $1.8 \frac{m}{s^2}$ and the deceleration $-4 \frac{m}{s^2}$. The vehicle transitioning reaches a deceleration of $-1.2 \frac{m}{s^2}$, aiming to compensate the disparity. The speed after the transition is reduced to 26.8 m/s.

Analyzing figures 5-11 and 5-13, we see that uncomfortable acceleration is exploited also in the alignment interval. It happens because the parameters of the control system (spring constant and damping coefficient) are settled in order to exit the repulsion zone in time. Then, the same parametrization is used for the whole simulation time. However, it is not necessary to develop harsh accelerations when the safety requirements

are achieved. In the future, it may be considered to reset the parameters for comfortable behaviors when the safety requirements are achieved.

Table 10 shows the average and maximum values of acceleration and jerk registered. It includes all the vehicles. It is worth to mention that no modification has been made to the controller when varying the time buffer. The controller receives in input the supposed duration of the transition, and all the parameters are decided accordingly, resulting in different motions.

Table 10 Comfortability evaluation parameters with time buffer equal to 8 s

Vehicle ID	$\ddot{x}_{max} [\frac{m}{s^2}]$	$\ddot{\ddot{x}}_{max} [\frac{m}{s^3}]$	$\bar{\ddot{x}} [\frac{m}{s^2}]$	$\bar{\ddot{\ddot{x}}} [\frac{m}{s^3}]$
10	1.29	0.61	0.16	0.1
3	1.81	1.42	0.55	0.24
8	1.49	1.01	0.51	0.18
9	3.23	1.81	1.03	0.31
5	1.77	1.22	0.59	0.23
7	1.5	1.02	0.49	0.18
13	3.96	1.87	0.78	0.35
18	2.8	1.28	0.82	0.25
0	2.23	1.51	0.6	0.26
11	4.04	2.09	0.99	0.38
20	3	1.54	0.78	0.26
4	1.69	1.25	0.54	0.21
21	2.65	1.14	0.76	0.24
12	3.12	1.63	0.95	0.29
2	2.2	1.31	0.62	0.24
19	3.2	1.58	0.67	0.28
15	2.97	1.46	0.89	0.27
6	1.78	1.28	0.49	0.21
1	2.18	1.3	0.63	0.26
14	3.33	2.01	0.92	0.32
16	3.39	1.73	0.72	0.3
17	3.18	1.77	0.85	0.29

6 Conclusions and Future Work

In this chapter, a summary of all the outcomes of this work will be presented. Moreover, some suggestions for improving the control model will be given.

6.1 Conclusions

We can divide the conclusions derived from this thesis into two areas. First, we have provided a new solution to vehicle transition from autonomous to manual mode. Furthermore, we have laid the foundation for the development of a modern system for traffic control.

A cooperative protocol that can satisfy the requirements derived by vehicle transition has been developed. The evolution of cellular communication technology permits automakers to enable new solutions. Each vehicle can be controlled independently, but with benefits regarding the group. Cooperation between vehicles will be enabled by C-V2X technology. All vehicles will be connected to the same network, exchange of information creates a knowledge which can be positively exploited. The environment in which the protocol has been tested is a highway. The highway has been chosen because, being a high-speed environment, it represents the location in which switching from autonomous to manual causes a higher risk. Moreover, in our simulations, the road space was completely saturated by vehicles. Hence, vehicles were positioned at a longitudinal distance precisely equal to the safe space they need, and they occupied all three lanes of the highway. It consists of the worst-case scenario. In fact, the controller has to allocate all the space needed for the vehicle transitioning with no space available around it when the transition begins. After having defined the space needed by the vehicle transitioning, we can outline if any vehicle is occupying it at the end of the transition. When a vehicle is positioned inside the area, it can be considered at risk. Our simulations drive to the following conclusions:

- A protocol to manage the spatial requirements of vehicles on the road has been developed. It consists of a traffic control model that exploits the analogy with the SMD system to manage the longitudinal behavior of CAVs.
- The model avails itself of the capacity to find an equilibrium point based on the fundamental parameters of the SMD system. In the specific, we refer to the spring constant k , the relaxation length of the spring l , and the damping coefficient b .
- In chapter 3.2, we have provided valid methods for the definition of the parameters. In particular, l will define the equilibrium condition of the system based on the spatial requirements of all vehicles. k will define the acceleration rate of vehicles; hence, how rapidly vehicles will reach the equilibrium disposition. b is settled after k to give stability to the system.
- Dynamic variation of the parameters satisfies the system requirements while they continuously change within time.

- The protocol can solve the issues created by the vehicle transitioning. The space allocated will permit the pilot to manifest driving irregularities without compromising the safety of other vehicles, and also reducing the risk associated with himself. For what regards the reacquisition of situation awareness, the concept is the same.
- The controller performance is limited by the communication technology and acceleration/ deceleration capabilities of vehicles; both modeled in our simulations.
- The efficiency of the process is dependent on the time available. If the time interval is relatively large, the controller can respect the requirements of the vehicle transitioning. When the time interval is reduced, the operations become harsh and inefficient.
- When the time available for the transition is 16 s or higher, the controller is able to allocate all the space needed in a way that is comfortable for all the passengers of vehicles involved. Acceleration and jerk of vehicles do not exceed the level for comfortability, respectively $1 \frac{m}{s^2}$ and $0.9 \frac{m}{s^3}$.
- When the time buffer is 8 s or higher, the controller is able to allocate all the space needed fulfilling safety requirements.
- When the time buffer is lower than 6 s, the final condition cannot be considered safe, and alternative methods should be considered.

On the other hand, we have also established the foundation for a new method of traffic control. The same concept that we have applied to transition can be exploited in numerous cases. Cooperation is based on two passages: first, the relationships between the entities must be defined; then, the rules laying on the relations should be settled. For animals (e.g., birds flying in a flock) these rules have been defined within their evolution, and they represent a set of action-reaction mechanisms that make them move while cooperating. Fishes protect themselves by swarming in a group; birds fly in the flock to exploit air current in the most efficient way. This thesis has applied the same concept to cooperation between vehicles, with identical purposes: increasing safety and efficiency. Most traffic conditions can be summarized in proper requirements in terms of space and time. The Centralized Controller takes in input the space needed and the time available. Then, it sets the relations between vehicles, and it defines the rules to be followed.

As said, the procedure has been applied explicitly to the case of vehicle transitioning. However, multiple traffic events can be described in terms of space and time. Hence, it becomes possible to analyze them with the same controller. The ramp entrance is an example of a traffic event that can be resumed with the space needed by the vehicle incoming from the ramp and the time in which it will enter the highway.

6.2 Future Work

More studies are needed to catch more precisely the requirements of pilots subjected to transition. Different traffic characteristics, weather conditions, and physical/psychological states of the pilot should be tested. It

can be done exploiting simulations on vehicle simulator, testing multiple conditions on real drivers. Moreover, the controller requires knowledge of the time buffer in order to be efficient. Hence, automakers should work on methods to detect a transition and understand precisely the time available.

The Centralized Controller, in our simulations, is modeling an environment with a penetration rate of 100% of autonomous and connected vehicles. Hence, all vehicles receive the acceleration indications and they are able to actuate it perfectly. In the future, it will be needed to generalize the case reducing the penetration rate of both autonomous and connected vehicles and modeling driver behavior. New sources of imprecision will arise, such as driver imperfection. The efficiency of the protocol in non-ideal conditions may be reduced drastically and they should be tested.

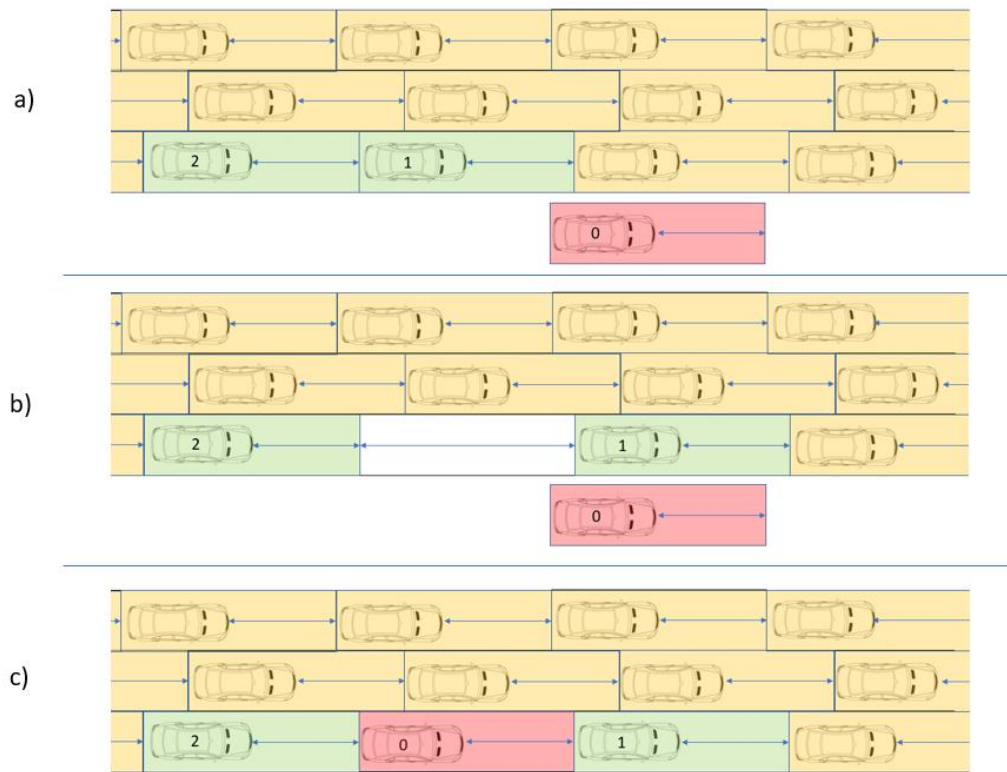

Figure 6-1 Cooperative ramp entrance maneuver

On the other hand, we are conscious of the importance that the controller may have for traffic control, outside the case of transition. We have developed the controller to react to transition, but it provides a general method to respect the requirements of vehicles on the road. Hence, it may control the traffic flow in multiple conditions. For example, let us consider a ramp entrance, referring to figure 6-1. Figure 6-1 a) represents the moment in which a vehicle decides to enter the highway. Supposing high-density traffic, as

shown in the same figure, the procedure starts with no space available for *vehicle 0* inside the highway. Knowing the distance from the entrance, and setting the speed behavior for all the vehicles, we can understand which position *vehicle 0* will enter (in this case between *vehicle 1* and *vehicle 2*). By using the same control method, space can be allocated in advance aiding *vehicle 0* to enter the highway efficiently. The passages are shown in figure 6-1 b) and c).

Also, the controller may be used to manage the steady-state flow, controlling the relative distance between all vehicles. The analysis starts with understanding the requirements of the vehicle. If these requirements can be parametrized as space needed by the vehicle in time, the controller should be able to manage the operations.

A control model for lane-changing decisions is also missing. During the transition, the majority of space must be freed in the longitudinal direction. The protocol has shown its capabilities to manage the transition in high-density traffic, even without considering the switching of lanes. However, the efficiency of the operations will be improved by implementing a lane-changing model.

The SMD system is built around acceleration, relative position, and speed. The longitudinal behavior of vehicles is derived from the same variables. Thus, it is appropriate to set an analogy between the two systems. Instead, the SMD system lacks the proprieties needed to consider lane-changing. The space can be increased only considering lanes independently. Hence, the controller should be improved by inserting rules for lane changing, in addition to the ones defined for the longitudinal behavior.

Current lane-changing models want to mime the real behavior of the pilot. Hence, they are defined by analyzing the desires of a human driver that will make a choice based on personal positive and negative outcomes. In the vision of our controller, the lane-changing behavior should be based on the positive and negative outcomes for the group.

Figure 6-2 shows a proposal for the rules of lane-changing. In the case of transition, we will need to allocate the space shown in figure 6-2 a). Without lane changing, the vehicles will allocate space by accelerating, until each has traveled a distance equal to s . The total amount of distance traveled, summing all the components of the four vehicles, will be equal to $4 * s$. This condition is represented in figure 6-2 b). An intelligent and coordinated lane-changing model should contain an algorithm that tries to reduce the total distance covered by the vehicles involved. Referring to figure 6-2 c), while vehicle 1 has covered a distance equal to s , the other vehicles have kept the same longitudinal distance as before. The reduction of the longitudinal distance traveled comes with a single lane-changing maneuver actuated by vehicle 2. We understand that the total distance traveled is reduced in this case, and it can be seen as a more satisfactory disposition.

Hence, once understood the requirements, the controller may create a function that calculates which lane-changing process creates a minimum in the distance covered by all vehicles. Figure 6-2 represents a simplified analysis that may be considered in the future when developing cooperative lane-changing model.

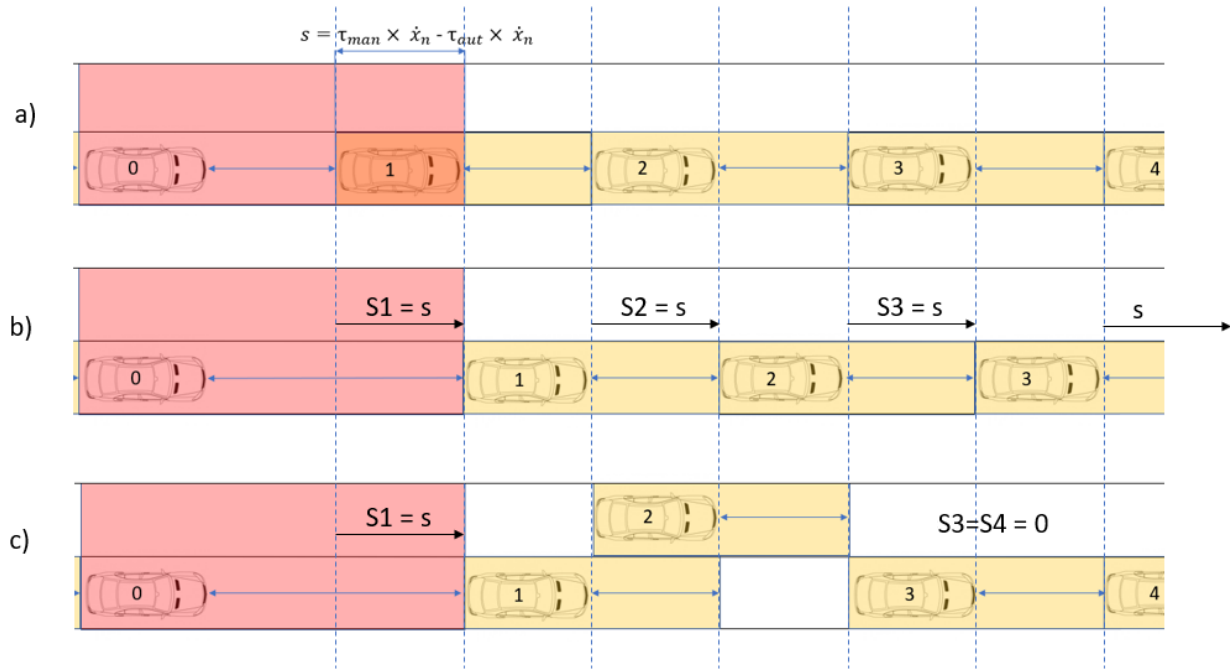

Figure 6-2 Example of intelligent lane changing scheme

Here, we resume the future steps of this thesis:

- It is possible to generalize the solution implemented for vehicle transition. Different conditions and CAVs penetration rates should be investigated. A higher number of experiments may also provide more details on the requirements of a driver subjected to transition. A more profound investigation of methods to calculate the time buffer (critical for our protocol) is needed.
- It is also possible to adapt the controller to manage various events exploiting the same framework. It should also implement a cooperative lane-changing model which considers the benefits brought for the group of vehicles. Also, it will be important to study the impact of the traffic control on system performance (delay, travel time).

REFERENCES:

- [1] Suzanne Murtha, “Autonomous vs Connected Vehicles: What’s the Difference,” 2015. [Online]. Available: <https://www.atkinsglobal.com>. [Accessed: 25-Jan-2019].
- [2] EUROPEAN COMMISSION, “Roadmap on Highly Automated vehicles,” pp. 1–16, 2016.
- [3] I. Savage, “Comparing the fatality risks in United States transportation across modes and over time,” *Res. Transp. Econ.*, 2013.
- [4] A. Albers and N. Aeronautics, “Aviation Safety and Automation Technology for Subsonic Transports,” 2009.
- [5] R. N. Charette, “Indonesian Safety Committee Releases Preliminary Report into Lion Air Crash.” [Online]. Available: <https://spectrum.ieee.org>. [Accessed: 15-Jan-2019].
- [6] M. T. Report, “Automation in Aviation — Guidelines Center for Advanced Aviation System Development Table of Contents,” no. 16, 2019.
- [7] S. M. Casner and E. L. Hutchins, “What Do We Tell the Drivers? Toward Minimum Driver Training Standards for Partially Automated Cars,” *J. Cogn. Eng. Decis. Mak.*, vol. 13, no. 2, pp. 55–66, 2019.
- [8] S. R. K. Narla, “The evolution of connected vehicle technology: From smart drivers to smart cars to... self-driving cars,” *ITE J. (Institute Transp. Eng.)*, 2013.
- [9] J. L. Vieira, “Self-Driving Cars: Levels of automation of a vehicle,” 2017. [Online]. Available: <https://medium.com/breathe-publication/self-driving-cars-levels-of-automation-of-a-vehicle-8ebb7f9a3e13>.
- [10] E. Union and C. Smart, “How EU funding contributes to connected and automated driving,” 2020.
- [11] E. W. Group and A. Driving, “Connected Automated Driving Roadmap Status: final for publication,” 2019.
- [12] N. Merat, A. H. Jamson, F. C. H. Lai, M. Daly, and O. M. J. Carsten, “Transition to manual: Driver behaviour when resuming control from a highly automated vehicle,” *Transp. Res. Part F Traffic Psychol. Behav.*, vol. 27, no. PB, pp. 274–282, 2014.
- [13] C. Gold, D. Damböck, L. Lorenz, and K. Bengler, “Take over! How long does it take to get the driver back into the loop?,” *Proc. Hum. Factors Ergon. Soc.*, pp. 1938–1942, 2013.
- [14] A. Borowsky, W. J. Horrey, Y. Liang, A. Garabet, L. Simmons, and D. L. Fisher, “The Effects of Momentary Visual Disruption on Hazard Anticipation and Awareness in Driving,” *Traffic Inj. Prev.*, 2015.
- [15] D. A. Norman and T. Shallice, “Attention to action: Willed and automatic control of behaviour (Revised reprint of Norman and Shallice (1980)),” in *Consciousness and Self-Regulation: Advances in Research and Theory*, 1986.
- [16] W. Vlakveld and SWOV, “Transition of control in highly automated vehicles A literature review,” pp. 1–30, 2015.
- [17] A. Spulber, “Impact of Automated Vehicle Technologies on Driver Skills,” 2016.
- [18] N. Merat, A. H. Jamson, F. C. H. Lai, M. Daly, and O. M. J. Carsten, “Transition to manual: Driver behaviour when resuming control from a highly automated vehicle,” *Transp. Res. Part F Traffic Psychol. Behav.*, 2014.
- [19] M. H. Michael R. James, Katsuhiko Sakai, Toshiki Kindo, Danil V. Prokhorov, “Transitioning between operational modes of an autonomous vehicle,” 9884631, 2015.
- [20] S. Hoogendoorn and V. Knoop, “Traffic flow theory and modelling,” *Transp. Syst. Transp. Policy An Introd.*, pp. 125–159, 2012.
- [21] Y. W. and P. A. I. H. Chang, “The Use of Microscopic Traffic Simulation Model for Traffic Control Systems,” *2007 Int. Symp. Inf. Technol. Converg. (ISITC 2007)*, 2007.
- [22] S. Bang and S. Ahn, “Platooning Strategy for Connected and Autonomous Vehicles: Transition from Light Traffic,” *Transp. Res. Rec. J. Transp. Res. Board*, vol. 2623, no. 1, pp. 73–81, 2017.

- [23] C. R. Munigety, "A spring-mass-damper system dynamics-based driver-vehicle integrated model for representing heterogeneous traffic," *Int. J. Mod. Phys. B*, vol. 32, no. 11, 2018.
- [24] Z. Li, F. Khasawneh, X. Yin, A. Li, and Z. Song, "A New Microscopic Traffic Model Using a Spring-Mass-Damper-Clutch System," *IEEE Trans. Intell. Transp. Syst.*, pp. 1–10, 2019.
- [25] S. Bang and S. Ahn, "Mixed Traffic of Connected and Autonomous Vehicles and Human-Driven Vehicles: Traffic Evolution and Control using Spring-Mass-Damper System," *Transp. Res. Rec.*, pp. 1–12, 2019.
- [26] S. Bang and S. Ahn, "Control of connected and autonomous vehicles with cut-in movement using spring mass damper system," *Transp. Res. Rec.*, vol. 2672, no. 20, pp. 133–143, 2018.
- [27] J. Eyre, D. Yanakiev, and I. Kanellakopoulos, "A simplified framework for string stability analysis of automated vehicles," *Veh. Syst. Dyn.*, vol. 30, no. 5, pp. 375–405, 1998.
- [28] Woodward Communications and F. H. Administration, "Next Generation Traffic Control Systems," p. 42, 2015.
- [29] K. Jadaan, S. Zeater, and Y. Abukhalil, "Connected Vehicles: An Innovative Transport Technology," *Procedia Eng.*, vol. 187, pp. 641–648, 2017.
- [30] Y. Chen, J. Gonder, S. Young, and E. Wood, "Quantifying autonomous vehicles national fuel consumption impacts: A data-rich approach," *Transp. Res. Part A Policy Pract.*, vol. 122, no. November 2017, pp. 134–145, 2019.
- [31] N. Lu, N. Cheng, N. Zhang, X. Shen, and J. W. Mark, "Connected vehicles: Solutions and challenges," *IEEE Internet Things J.*, vol. 1, no. 4, pp. 289–299, 2014.
- [32] Next Generation Mobile Networks Alliance 5G Initiative, "5G White Paper," *A Deliv. by NGMN Alliance*, p. 124, 2015.
- [33] ETSI, "22.186 - 5G; Service requirements for enhanced V2X scenarios (3GPP TS 22.186 version 15.4.0 Release 15)," 2018.
- [34] M. Lauridsen, L. C. Giménez, I. Rodriguez, T. B. Sørensen, and P. Mogensen, "From LTE to 5G for Connected Mobility," *IEEE Commun. Mag.*, vol. 55, no. 3, pp. 156–162, 2017.
- [35] C. Mobile Li Feng *et al.*, "V2X White Paper by NGMN Alliance," *NGMN Alliance*, 2018.
- [36] ETSI, "MEC Deployments in 4G and Evolution Towards 5G About the authors," *Etsi Mec*, no. 24, 2018.
- [37] D. Carew, N. Martin, M. Blumenthal, P. Armour, and J. Lastunen, "The Potential Economic Value of Unlicensed Spectrum in the 5.9 GHz Frequency Band: Insights for Future Spectrum Allocation Policy," *Potential Econ. Value Unlicensed Spectr. 5.9 GHz Freq. Band Insights Futur. Spectr. Alloc. Policy*, 2018.
- [38] Z. Xu, X. Li, X. Zhao, M. H. Zhang, and Z. Wang, "DSRC versus 4G-LTE for connected vehicle applications: A study on field experiments of vehicular communication performance," *J. Adv. Transp.*, vol. 2017, 2017.
- [39] C. Bettisworth *et al.*, "Status of the Dedicated Short-Range Communications Technology and Applications Report to Congress," no. July, p. 214, 2015.
- [40] J. B. Kenney, "Dedicated short-range communications (DSRC) standards in the United States," *Proc. IEEE*, vol. 99, no. 7, pp. 1162–1182, 2011.
- [41] G. Naik, B. Choudhury, and J. M. Park, "IEEE 802.11bd 5G NR V2X: Evolution of Radio Access Technologies for V2X Communications," *IEEE Access*, vol. 7, pp. 70169–70184, 2019.
- [42] X. Wang, S. Mao, and M. X. Gong, "An Overview of 3GPP Cellular Vehicle-to-Everything Standards," *GetMobile Mob. Comput. Commun.*, vol. 21, no. 3, pp. 19–25, 2017.
- [43] J. Yoshida, "EU Adds Suspense to DSRC vs. C-V2X." [Online]. Available: https://www.eetimes.com/document.asp?doc_id=1334544#.
- [44] 5G Automotive Association, "An assessment of direct communications technologies for improved road safety in the EU," no. December, pp. 1–80, 2017.
- [45] A. Tipirneni, "Cellular – V2X (Vehicle-to-Everything) Technology Readiness Results C-V2X gaining support from

- automotive and telecom leaders,” 2018.
- [46] L. Samsung Electronics Co., “Dawn of the 5G Era Immersive Multimedia Experience,” no. August, pp. 1–5, 2015.
- [47] Y. Niu, Y. Li, D. Jin, L. Su, and A. V. Vasilakos, “A survey of millimeter wave communications (mmWave) for 5G: opportunities and challenges,” *Wirel. Networks*, vol. 21, no. 8, pp. 2657–2676, 2015.
- [48] GSMA, “Cellular Vehicle-to-Everything (C-V2X) Enabling Intelligent Transport,” p. 20, 2017.
- [49] D. Thembelihle, M. Rossi, and D. Munaretto, “Softwarization of Mobile Network Functions towards Agile and Energy Efficient 5G Architectures: A Survey,” *Wirel. Commun. Mob. Comput.*, vol. 2017, 2017.
- [50] S. Li, L. Da Xu, and S. Zhao, “5G Internet of Things: A survey,” *J. Ind. Inf. Integr.*, vol. 10, no. January, pp. 1–9, 2018.
- [51] P. Popovski, K. F. Trillingsgaard, O. Simeone, and G. Durisi, “5G wireless network slicing for eMBB, URLLC, and mMTC: A communication-theoretic view,” *IEEE Access*, vol. 6, no. 648382, pp. 55765–55779, 2018.
- [52] G. S. Network and W. Group, “From Webscale to Telco , the Cloud Native Journey,” no. July, pp. 1–25, 2018.
- [53] 5GPPP, “View on 5G Architecture (Version 2 . 0),” *5Gppp*, no. July, 2017.
- [54] 5GAmericas, “Wireless Technology Evolution Towards 5G:,” *5G Am.*, pp. 1–243, 2017.
- [55] C. Campolo, A. Molinaro, A. Iera, and F. Menichella, “5G network slicing for vehicle-to-everything services,” *IEEE Wirel. Commun.*, 2017.
- [56] A. Reznik, “Multi-access Edge Computing (MEC).” [Online]. Available: <https://www.etsi.org/technologies/multi-access-edge-computing>.
- [57] SpectraCells, “C-V2X In Depth Part 1,” 2018. [Online]. Available: <http://spectracells.com/2018/09/07/cv2x/>.
- [58] M. Flament, “Making connected cars a reality with 5G (and LTE),” pp. 1–37.
- [59] M. S. Elbamby *et al.*, “Wireless Edge Computing With Latency and Reliability Guarantees,” *Proc. IEEE*, pp. 1–20, 2019.
- [60] Qualcomm, “Accelerating C-V2X commercialization,” 2017.
- [61] C. Cordero, “Optimizing 5G for V2X -,” 2016.
- [62] SAE, “The Navigator: As the world turns to C-V2X, Europe picks WiFi.” [Online]. Available: <https://www.sae.org/news/2019/06/the-navigator-c-v2x>.
- [63] GSMAIntelligence, “5G in China : the enterprise story,” 2018.
- [64] A. Jovetic, “European Parliament Backs WiFi over 5G in Connected Cars Despite Intense Lobbying.” [Online]. Available: <https://www.european-views.com/2019/04/european-parliament-backs-wifi-over-5g-in-connected-cars-despite-intense-lobbying/>.
- [65] T. G. R. Reid *et al.*, “Localization Requirements for Autonomous Vehicles,” pp. 1–16, 2019.
- [66] Novatel, “An Introduction to GNSS.” [Online]. Available: <https://www.novatel.com/an-introduction-to-gnss/chapter-1-gnss-overview/>.
- [67] N. Bhandari, “Working of GPS,” 2018. [Online]. Available: <http://tutorialbyte.com/2018/02/05/working-of-gps/>.
- [68] I. Fernandez-Hernandez *et al.*, “Galileo high accuracy: A program and policy perspective,” *Proc. Int. Astronaut. Congr. IAC*, vol. 2018-Octob, no. February 2018, pp. 1–9, 2018.
- [69] Y. Feng and J. Wang, “GPS RTK Performance Characteristics and Analysis,” *J. Glob. Position. Syst.*, vol. 7, no. 1, pp. 1–8, 2008.
- [70] K. Ong-a-fat, “Context Aware Gps: error correction,” 2012.
- [71] H. Wymeersch, G. Seco-Granados, G. Destino, D. Dardari, and F. Tufvesson, “5G mmwave positioning for vehicular networks,” *IEEE Wirel. Commun.*, vol. 24, no. 6, pp. 80–86, 2017.
- [72] G. De Angelis, G. Baruffa, and S. Cacopardi, “GNSS/cellular hybrid positioning system for mobile users in Urban scenarios,” *IEEE Trans. Intell. Transp. Syst.*, vol. 14, no. 1, pp. 313–321, 2013.
- [73] H. Wymeersch *et al.*, “5G mm Wave Downlink Vehicular Positioning,” *2018 IEEE Glob. Commun. Conf. GLOBECOM*

2018 - Proc., no. 1, 2018.

- [74] Bosch, "Redundant System Automated Driving." [Online]. Available: <https://www.bosch.com/stories/redundant-systems-automated-driving/>.
- [75] V. Communications and A. B. Service, "Etsi Ts 102 637-2 V1.2.1," vol. 1, pp. 1–18, 2011.
- [76] B. Chazelle, "The convergence of bird flocking," *J. ACM*, vol. 61, no. 4, pp. 422–431, 2014.
- [77] D. Jeong, K. Lee, and C. Western, "Dispersion and Line Formation in Artificial Swarm Intelligence," *Conference*, pp. 2–5, 2014.
- [78] MIT open course, "Under, Over and Critical Damping 1. Response to Damping," pp. 2–7, 2011.
- [79] B. Walker, "The external sensors you'll find in the modern car," 2018. [Online]. Available: <https://360.here.com/external-sensors-in-modern-cars>.
- [80] J. Han, Y. Liao, J. Zhang, S. Wang, and S. Li, "Target fusion detection of LiDAR and camera based on the improved YOLO algorithm," *Mathematics*, vol. 6, no. 10, 2018.
- [81] SUMO, "SUMO User Documentation," 2019. [Online]. Available: https://sumo.dlr.de/wiki/SUMO_User_Documentation.
- [82] A. Varga, "OMNeT++ Simulation Manual," *OMNeT++ Simul. Man.*, pp. 3–6, 2016.
- [83] P. P. Algorithm, J. Eriksson, and L. Svensson, "Tuning for Ride Quality in Autonomous Vehicle," 2015.

VITA AUCTORIS

Stefano Caserini was born in 1995 in Milan, Italy. He graduated from Liceo Scientifico Niccolò Copernico in 2013. From there he went on to the University of Pavia where he obtained a B.Sc. in Mechanical Engineering in 2017. He is currently a candidate for the Dual Master's degree in Automotive Engineering at the University of Windsor and Politecnico di Torino and hopes to graduate in 2020.