

POLITECNICO DI TORINO

Dipartimento di Ingegneria Informatica, del Cinema e Meccatronica

Corso di Laurea Magistrale in Mechatronic Engineering
(Ingegneria Meccatronica)

Tesi di Laurea Magistrale

Upgrade and improvement of UAPFOR machine for electromechanical fatigue testing in ABB ELSB Laboratory



**Politecnico
di Torino**

Relatore

Prof. Marcello Chiaberge

Candidato

Lorenza Curcio

Tutor aziendale

Ing. Jacopo Federico Sasso

Dott. Giuseppe Bertolotto Bianc

Anno Accademico 2023/2024

ABSTRACT

This thesis project has been developed in ABB Smart Building in Vittuone (MI) with the purpose of doing a revamping of a machine used to do fatigue tests on RCBO, RCCB and other types of products developed by ABB and tested in the R&D Laboratory for certification before putting them on the market.

More specifically, the main objective of this thesis project was the modification of both hardware and software with the purpose of improving the control logic, the analysis, and data management and to update the HMI, evaluating and analysing also the impact that these modifications have on the whole performance of the machine.

The choice of installing an Industrial PC and the Automation Studio software allow to improve the control precision, to optimize the management of the I/Os and to provide an interface that is more intuitive from the operator side.

The final aim is to also evaluate the influence of these modifications on the global performance of the machine, considering factors as the increasing of the productivity and the improvement of the quality of the products thanks to more precise measurements and data obtained from the tests; all the advantages that R&D should have with a machine able to execute more complex actions.

The thesis structure follows a logical path that allows to present in a clear, precise, and coherent manner the developed job activity.

INDEX

Table of figures	7
1. INTRODUCTION	11
1.1 ABB COMPANY OVERVIEW	11
2. THEORETICAL FUNDAMENTALS	13
2.1 INDUSTRIAL AUTOMATION OVERVIEW	13
2.2 COMPARISON BETWEEN PLC AND INDUSTRIAL PCs.....	16
2.3 B&R SOFTWARE OVERVIEW	18
3. UAPFOR MACHINE PURPOSE	21
3.1 PRODUCTS UNDER TEST	21
4. STARTING HARDWARE MACHINE OVERVIEW	25
4.1 STARTING HARDWARE: ELECTRICAL PART	25
4.2 STARTING HARDWARE: MECHANICAL PART	30
4.3 STARTING HARDWARE: CONTROL PART	31
5. STARTING SOFTWARE MACHINE OVERVIEW	35
5.1 STARTING SOFTWARE	35
5.2 STARTING HUMAN MACHINE INTERFACE	39
6. REVAMPED MACHINE	46
6.1 HARDWARE MODIFICATION: ELECTRICAL PART	46
6.2 HARDWARE MODIFICATION: CONTROL PART	49
6.3 SOFTWARE MODIFICATIONS.....	53
7. TESTING PHASE	62
8. FUTURE IMPROVEMENTS	64
9. CONCLUSIONS	65
10. BIBLIOGRAPHY	66
ANNEX A	67
ANNEX B	72
ANNEX C	76

TABLE OF FIGURES

Figure 1.1: ABB global overview	11
Figure 2.1: B&R Automation Studio operating fields	19
Figure 4.1: Measurement instruments for loads current and voltage	25
Figure 4.2: Original measurement displays.	26
Figure 4.3: Load switches console	26
Figure 4.4: Measurement instruments for differential current.....	27
Figure 4.5: Original measurement displays.	27
Figure 4.6: Differential current selection	28
Figure 4.7: Rheostats settings table.....	28
Figure 4.8: Pneumatic circuit	30
Figure 4.9: PLC AC500 with Panel CP650	31
Figure 4.10: Front Panel.....	32
Figure 4.11: Terminal base TB511-ETH	33
Figure 4.12: Digital Input module DI524	33
Figure 4.13: Digital Input/Output module DC523	34
Figure 5.1: HMI Test Page.....	39
Figure 5.2: Test Page editable fields	40
Figure 5.3: Active recipe type	41
Figure 5.4: Active recipe settings.....	41
Figure 5.5: Info FERMATA PROGRAMMATA section	42
Figure 5.6: Reset Button.....	43
Figure 5.7: HMI Recipe Page.....	43
Figure 5.8: Recipe duplication procedure	44
Figure 6.1: M4M	46
Figure 6.2: Keithley connections for voltage drops measurements	47
Figure 6.3: Keithley connections for differential current and resistance measurements	47
Figure 6.4: 2000-SCAN connections	48
Figure 6.5: Loads circuit	48

Figure 6.6: Old machine panel drawing	49
Figure 6.7: New machine panel drawing	49
Figure 6.8: Uapfor machine panel buttons.....	50
Figure 6.9: Hardware architecture in Automation Studio.....	51
Figure 6.10: PLC set-up drawing	52
Figure 6.11: Keithley and M4M connection to Hub Ethernet	52
Figure 6.12: Home Page.....	53
Figure 6.13: Loads circuit status.	54
Figure 6.14: Alarm Page	55
Figure 6.15: Test Configuration Page	56
Figure 6.16: Cylinders times setting.	56
Figure 6.17: Enabling manual maneuvers.....	57
Figure 6.18: Recipes Managemen.....	57
Figure 6.19: Loads Setting	58
Figure 6.20: Settings for automatic test for loads setting	59
Figure 6.21: Automatic test results	59
Figure 6.22: Settings Page.....	60
Figure 6.23: User Management Page	61
Figure A.1: Original PLC digital inputs.....	67
Figure A.2: Original PLC digital inputs.....	67
Figure A.3: Original PLC digital inputs.....	68
Figure A.4: Original PLC digital outputs.....	68
Figure A.5: Original PLC digital outputs.....	69
Figure A.6: Original PLC digital outputs.....	69
Figure A.7: Original PLC digital inputs/outputs.....	70
Figure A.8: Original PLC digital inputs/outputs.....	70
Figure A.9: Original PLC digital inputs/outputs.....	71
Figure B.1: New PLC digital inputs.....	72
Figure B.2: New PLC digital inputs.....	72
Figure B.3: New PLC digital inputs.....	73
Figure B.4: New PLC digital outputs.....	73

Figure B.5: New PLC digital outputs..... 74
Figure B.6: New PLC digital inputs/outputs..... 74
Figure B.7: New PLC digital inputs/outputs..... 75
Figure C.1: Loads PLC digital inputs 76
Figure C.2: Loads PLC digital inputs 76
Figure C.3: Loads PLC digital inputs 77
Figure C.4: Loads PLC digital outputs 77
Figure C.5: Loads PLC digital outputs 78
Figure C.6: Loads PLC digital outputs 78
Figure C.7: Loads circuit relay bases 79

CHAPTER 1

INTRODUCTION

1.1 ABB COMPANY OVERVIEW

The following thesis project has been developed in the R&D Laboratory of the Electrification Smart Building of ABB in Vittuone (MI) and has as main objective the revamping of a UAPFOR machine, used to test the fatigue life cycle of different types of RCCBs, RCBOs. In the Industrial Automation field and, particularly in this case, in R&D, these machines have a very important role to the testing process of a product. These machines, in fact, are developed to execute cyclically a set of operations, with the aim of testing the strength and the duration in time of the different components. However, the efficiency, the precision, the collection, and data analysis of these machines could be optimized and renewed through their modification.



Figure 1.1: ABB global overview

ABB Electrification is a company, worldwide leader in the electrification field. It was founded in 1883, ABB has grown to become a multinational organization with a wide range of products and solutions in the energy and automation field. ABB Electrification is mainly focused on providing innovative solutions for industrial, commercial, and residential electrification. The company offers a wide range of products, included distribution systems and energy control, protection devices and control, energy management equipment and solution to recharge electric vehicles.

With a strong reputation about the quality of its products and its technical expertise, ABB Electrification is committed to provide sustainable, efficient, and safe solutions to meet the need of its customers from all around the world. The aim of

the company is to promote innovation and energy efficiency, helping companies to achieve their sustainability objectives and to optimize their operations. The following map represents how big is the company and how is extended worldwide.

The collaboration with ABB for my thesis project allowed me to work closely with a cutting-edge company, and it gave me a chance to acquire knowledge and important skills in the industrial automation field.

This thesis project has been developed in ABB company with the usage of the B&R Industrial Automation hardware and software.

B&R Automation is a global company specialized in Industrial Automation and control systems. It is a member of the ABB group. The company was founded in 1979 in Austria and has since grown into one of the leading providers of automation solutions worldwide. B&R offers a comprehensive portfolio of products and services that cater to various industries, including manufacturing, automotive, packaging, food and beverage, and many others.

B&R Automation has established a reputation for innovation, reliability, and high-performance automation solutions. They continue to push the boundaries of industrial automation technology and provide customers with the tools and expertise they need to optimize their manufacturing processes and stay competitive in a rapidly evolving global market.

CHAPTER 2

THEORETICAL FUNDAMENTALS

2.1 INDUSTRIAL AUTOMATION OVERVIEW

Industrial automation has the purpose of improving the efficiency, productivity, and safety inside a production environment.

To do that, it uses advanced technologies like electronic systems and devices, computers, specialized software, and sensors with the aim of automatizing operations and controlling industrial processes.

The aim of industrial automation is to reduce at minimum, until possible, the human intervention in the production operations, improving the efficiency and guaranteeing higher precision and coherence in the activities. This allows the companies to reduce production costs, to improve the quality of the product and to improve the productivity that results in a competitive advantage on the market.

One of the main components of the industrial automation is the PLC (Programmable Logic Controller), a programmable electronic device used to control industrial processes. PLC can be programmed with the aim of executing a series of functions, like controlling motors, sensors, actuators, and other devices of input/output (I/O).

Another fundamental aspect of industrial automation, in fact, are the I/Os. They are used to connect the PLC to other devices like sensors or actuators, that are used to manage and control industrial processes. I/Os can be of different types like, for example, digital or analogical.

Industrial PCs are another important component for the industrial automation. They are highly specialized computers projected to operate in difficult industrial environments and could be used to execute a wide range of applications, like monitoring processes, data collection, visualization of the information and report generation.

Control logics are another important concept in the industrial automation. These logics are used to program PLCs and define how input/output devices interacts between each other to control processes. There are a lot of types of control logics, like waterfall logics, sequential logics, temporized logics and so on.

Finally, the human-machine interfaces (HMI) are used to visualize the information about the state of the industrial processes and allow the operators to control and

manage processes in real time. HMIs could be of different type, like displays, touch screens or keyboards.

Generally, industrial automation is a field continuously in evolution, that uses advanced technologies to improve the efficiency and safety of industrial processes. With the usage of the PLCs, Industrial PCs, I/O, control logics and HMI, industrial automation could help companies to obtain a higher profit, reducing costs and improving the quality of the products.

In the field of my thesis project the control logic of the PLC has the aim of automatizing the cyclic job executed on different products by the company to test their strength to fatigue cycles. It is a cyclic job that consists in cycles of even more than 10000 manoeuvres per each one; so, a job that should not be possible if not automatized.

PLCs are programmed using specific programming languages projected to allow engineers and operators to define the desired behaviour of them.

Some of the languages used are:

Ladder Diagram (LD): it takes this name from its visual aspect, like a ladder. It is based on the logic of contacts and coils, which contacts represents the inputs, and the coils represent the outputs. Instructions have been executed in sequence, from left to right, like stepping up a ladder. LD is particularly useful to program control logic circuits.

Function Block Diagram (FBD): it uses functional blocks to represents the instructions. Functional blocks could be connected between each other to create a complex control logic. This programming language is like the block programming used in lot of software developing environments.

Structured Text (ST): it is based on a text that uses a syntax like the one of traditional programming languages. It is particularly useful to write complex algorithms and to execute mathematical calculations. The structured text gives a higher flexibility and possibility of abstraction with respect to other programming PLC languages.

Instruction List (IL): it is based on a text that uses a set of specific instructions for the PLC. It is a low-level programming language that requires a deepest knowledge of the functions and instructions that are specific for the PLC. It is usually used when a detailed control on a specific process is needed.

Sequential Function Chart (SFC): it is a graphical programming language that uses different phases and transitions to represents sequences of actions. It is particularly useful to describe complex sequences of operations or process state sequences.

For what concerns this thesis project it has been used the Structured Text (ST) to develop the different function blocks, functions, and programs.

Most of PLCs support lot of different programming languages and this allow to use different languages inside the same project, as happen in the case of study in object, based on the specific needs. The choice of the programming language, in fact, depends on the type of the application, on the ability of the operators and on the programming standards adopted in each industrial contest.

2.2 COMPARISON BETWEEN PLC AND INDUSTRIAL PCs

The most significant hardware modification of this thesis project consists in the substitution of the PLC with and Industrial PC and in the following, there is a comparison between these two types of products.

PLCs and Industrial PCs are both used in the industrial automation field, but they differ from each other for the purpose, design, and functionality. The two hardware could be put in comparison, looking them by different point of view.

Aim: PLCs are specifically projected to control the automation of industrial processes. They are projected to work in difficult industrial environments, with extreme temperatures, vibrations, and electromagnetic interferences. PLCs are optimized for the reliability, response velocity and capacity to manage a high number of I/O signals in real time.

Industrial PCs are PCs at high performance used in industrial environments. They are projected to execute a wide range of applications, including process control, data visualization and managing of systems and network connectivity. Industrial PCs offers a higher flexibility and processing capacity with respect to PLCs, but they could be more sensitive to the difficult environmental conditions.

Reliability and resistance: PLCs are projected to be extremely reliable and resistant. They are built with strong components that can work in case of extreme temperature, dust, humidity, and vibrations. Furthermore, PLCs are good to work without turning off for long time periods and have safety mechanisms to protect data and system redundancy.

Industrial PCs offer a higher processing powerful with respect to PLCs, but they could be more sensitive to environmental conditions. Anyway, Industrial PCs are built with special characteristics to improve strength, like cooling systems, protections against dust and humidity, and protection layers for displays and keyboards.

Scalability and flexibility: PLCs are projected to be easily scalable and adaptable to different industrial applications. They are available in a wide range of dimensions, I/O capacity, and communication functionality. Furthermore, PLCs allow the connectivity with a wide range of peripheral devices, like sensors, actuators, and HMI. Industrial PCs offer a higher flexibility in terms of customization and adaptability to the specific needs of the application. They are equipped of high storage capacity, advanced connectivity options and could be configured to execute different operating systems and automation software.

Programmability: PLCs use specific programming languages, like the ones previously listed: LD, FBD, ST, IL- These languages are optimized for the control logic and the managing of the I/Os of the PLC. Programming software for PLC offers a development environment to create, test and manage the control logic of PLCs. Furthermore, PLCs

usually offers programming functionalities in real time, and allow to answer to input signals.

In Industrial PCs, a wide range of programming languages can be used, between C/C++, Java, Python, and other generic languages. This allows a higher flexibility in the choice of the programming language based on the specific needs of the application. Industrial PCs can execute more complex automation software and customized applications. They can manage high computational frequency operations and complex algorithms and advanced data analysis can be easily integrated.

Costs: PLCs are generally projected to be a low-cost solution, giving specific control functionalities for industrial applications. The PLC cost depends on its specifications, I/O capacities, and communication functionalities. However, PLCs could require an additive cost to buy specific programming software and expansion modules or needed accessories.

Industrial PCs tend to be more expensive with respect to PLCs because of their advanced elaboration characteristics and of their capacity to execute complex software. Furthermore, Industrial PCs requires software licenses to use the operating systems and the automation software. However, they give a higher flexibility and could reduce the whole cost of integration of different functionalities in only one device.

In conclusion, PLCs and Industrial PCs are devices with different aim and characteristics. PLCs are projected to control and automatize specific industrial automation processes, giving reliability, strength and are easily programmable through dedicated programming languages. Industrial PCs, on the other hand, offer higher flexibility, elaboration power and possibility to execute more complex software, but can require a higher attention to adapt to industrial conditions and with a higher cost. The choice between PLCs and Industrial PCs depends on the specific need of the application e from the control and industrial automation requirements.

2.3 B&R SOFTWARE OVERVIEW

One of the important modifications done during this thesis project has been the transfer of the whole old project on a new software platform. The transfer has been done from the ABB Automation Builder to the B&R Automation Studio software. During the first months of the stage done in ABB, I have had the opportunity of doing some courses to learn how to use Automation Studio software with B&R Automation.

In the following is reported an overview of both software.

The original project of the UAPFOR machine was developed on ABB Automation Builder software.

Automation Builder is a comprehensive software suite developed by ABB for programming, configuring, and maintaining automation solutions. It is designed to streamline the development process for ABB's automation products, including PLCs, drives, motion controllers and HMI devices.

Automation Builder provides a unified environment that integrates different tools and features to facilitate efficient automation project engineering.

Overall, Automation Builder simplifies the automation engineering process by providing a unified software platform for developing, configuring, and maintaining ABB's automation solutions. It helps to improve productivity, reduce development time, and ensure the reliability and performance of automation projects.

The new project has been developed on B&R Automation Studio software.

Automation Studio is the configuration environment used for B&R automation components, an ABB member. This includes controllers, motion control components, safety modules and HMI applications. Automation Studio offers the perfect environment to create different variants of a machine and managing them neatly. Projects can be structured clearly and facilitate teamwork in this way.

Users can choose from a wide range of programming languages, diagnostic tools, and editors to assist them at every stage of engineering. Standard libraries provided by B&R and the integrated IEC programming languages allow a highly efficient workflow. Extensive simulation options make it easier to configure and test applications independently of the hardware.

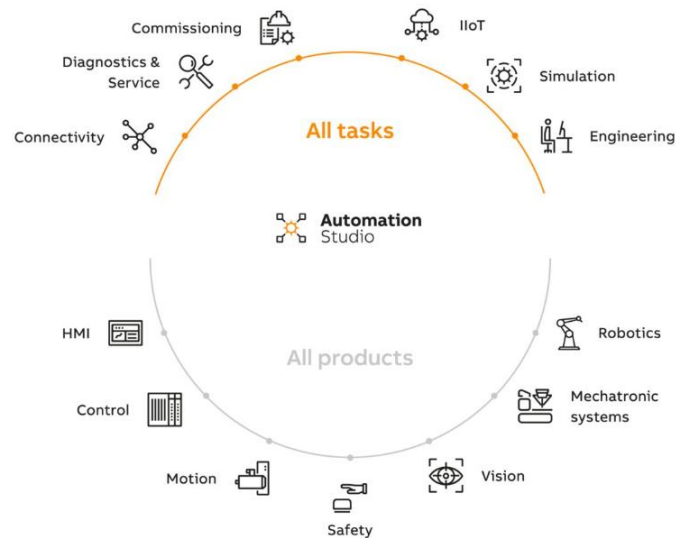

Figure 2.1: B&R Automation Studio operating fields

Automation Studio allow to configure the automation system defining the process variables, digital and analogical I/O, communication modules and other devices. It is possible to configure and easily customize the hardware using the graphic interface of the software.

As all the software used for programming PLCs allow to use the basic programming languages defined by the IEC 61131-3 that are: Ladder Diagram (LD), Function Block Diagram (FBD), Structured Text (ST), Instruction List (IL) and Sequential Function Chart (SFC), but also ANSI C.

It uses the so called mappTechnology which allows the developer in multiple fields like managing recipes, creating the HMI, creating the alarm system, user-role system and so on. Developers can create a user-role system, an alarm system or control movement sequence without writing code but using maps that can be configured in less time and few click of mouse.

During this thesis project different maps have been used for different purposes like mappServices for recipe management, alarm system and user-role system or mappView to develop the HMI using HTML5.

Automation Studio offers advanced instruments to create HMI that are intuitive and interactive. It is possible to project and customize displays, control panels, alarms, and other graphical elements to allow the operators to interact with the automation system. This software allows to add animation, advanced graphics, and interactive elements to the HMI to improve the experience of the operator and to ease the understanding of the control information.

Automation Studio offers also a very powerful and wide selection of diagnostic tools for reading system information and for optimizing the system.

During this thesis project the System Diagnostic Manager has been a very intuitive and powerful Web interface to understand if all the connections of PLC I/Os were correct. Furthermore, also the Logger has been a very important diagnostic tool to understand the cause of errors in the debug phase of the project.

Furthermore, using Automation Runtime Simulation, it has been possible to simulate the whole project on the PC itself. AS software offers a virtual simulation environment that allow to test the control logic before the real implementation. This allows to detect and correct errors or functioning problems of the system before is put into operation. At the end, the whole project runs on the CPU using B&R Hypervisor.

For what concerns the programming part, Automation Studio has a wide range of predefined function libraries that simplify the develop of the control logic. These libraries include modules to control the motors, to manage communications, to control the process and so on, accelerating the developing process and reducing the complexity of the code.

About the network connections field, it allows to establish network connections with the automation system, allowing the monitoring and the remote control through mobile devices or computers. This offers a higher flexibility in accessing and managing the automation system.

CHAPTER 3

UAPFOR MACHINE PURPOSE

3.1 PRODUCTS UNDER TEST

Product tested on the UAPFOR are the differential switches. They are electrical devices used to interrupt or close the current flux into an electric circuit. They are fundamental components for the electrical installations because they allow to control the power supply of the loads and devices connected to the system. There exist different types of differential switches, each one with its own characteristics and specific applications.

Of particular interest for the test there are the differential switches. They are known also as safety switch or differential protection switches. It is an electric device projected to detect and protect from dispersion currents or earth fault currents. Its principal function is to interrupt the electrical supply when it detects a current difference between the phase conductor and the neutral conductor.

The differential switch works monitoring constantly the input and output current from the circuit. The input current is the one that flows from the power supply system, while the output current is the one that flows through the loads connected to the circuit.

If the input and the output currents are balanced, the differential switch remains closed, and the electric circuit remains powered.

However, if there is a current difference, for example because of a current leakage or a failure, the differential switch detects this unbalance and opens instantaneously. Its response speed is very fast, in the order of milliseconds, to guarantee the people safety and to prevent circuit damages.

The differential switch could be of two different types, depending on its characteristics and applications. For example, a standard differential switch is deactivated when the difference of current overcome a defined threshold, usually of 30 mA. However, there could exist also differential switches at high sensibility, that could detect lower differences in current, like 10 mA.

These devices are widely used in residential, commercials and industrial electrical installations, because they give an efficient protection against the electric shocks and reduce the risk against them. It is important to notice that the differential switch does not substitute the automatic interrupter or the electric fuse to protection against overloads or short circuits, but it works synchronously with them, to guarantee a complete protection of the circuit.

For what concerns the internal structure of an internal differentiator, this could vary depending by the model, but normally it includes the following principal components:

- Differential coil: is the heart of the differential switch and detects the difference of current between the phase conductor and the neutral conductor. The coil is wrapped around a magnetic core and is connected in series to the circuit to protect.
- Current sensor: is a device that measures the current that flows through the circuit. It can be realized using a current coil or a current transformer. The sensor detects leakage currents or earth fault currents.
- Solenoid: is a winding of conducting wire that produce a magnetic field when crossed by a current. The solenoid is connected to a differential coil, and it activates when a significant differential current is detected.
- Contacts: the differential switches usually have two groups of contacts, one for the phase conductor, one for the neutral conductor. When the solenoid is activated, the contacts open instantaneously interrupting the current flux into the circuit.
- Drive mechanism is a system that connects the solenoid to the contacts. When the solenoid is activated, the drive mechanism starts to move, opening or closing the contact based on the detection of the current difference.
- Test button: differential switches are equipped of a test button that allow to simulate a current difference to check the correct behaviour of the switch.

Each model must respect requirements that are described into different CEI or IEC norms and starting from them are extrapolated all the data to set the number of cycles that the machine must execute to determine if a product is suitable or not.

A norm is a technical document that establish the technical requirements, guidelines or criteria for products, processes, or services. Norms are developed by an organization of standardization to promote the harmony, safety, efficiency, and interoperability in different sectors.

An example is the IEC 61009-1, and all the others are similar because they respect the same structure.

IEC and CEI EN are two organizations that work with norms and technical standards. In particular:

- IEC (International Electro Technical Commission) is an international organization that does norms in the electro technical field, in electronics and related technologies. IEC norms are globally recognized e are adopted by a lot of countries for their rules and technical requirements.
- CEI EN (Comitato Elettrotecnico Italiano Ente Nazionale) is an Italian organization that does the norms in the electro technical field in Italy. CEI adopts IEC norms like Italian norms (EN) and publish them as national technical norms.

Sometimes, CEI EN could include modifications or additional information to IEC norms to adapt them to specific requirements or Italian rules. These customizations

could include relevant aspects like safety and conformity requirements. IEC norms could be used as base to obtain the CE marking, that indicates the conformity to specific safety and health requirements provided by the Europe Union. This means that, to commercialize the product in Europe, is necessary to satisfy the requirements of the IEC norms and the additional requirements specifics for UE.

As an example, just to give an idea, the following part contains a summary explanation of the norm IEC 61009-1 for RCBOs.

RCBOs (Residual Current Circuit Breaker with Overcurrent Protection) are electrical devices that combines the functionalities of a differential switch (RCD) and of an automatic switch (MCB or MCCB) in one unique device. They are constructed to give a complete protection for the electric circuits against current leakages and overloaded. RCBOs monitors constantly the flux of current in the circuit and detects the minimal discrepancies between the input and the output current. If a significant difference is detected, this indicates a leakage of current or an earth fault current, RCBO immediately interrupts the circuit. RCBOs are equipped of a protection function against overload and short circuits. In case of strange increasing of the current into the circuit, like an overload or a short circuit, the RCBO detects the problem and stop the circuit to avoid damages to cables and electrical equipment. RCBOs are built to allow the selectivity, the capacity of stop only the portion of circuit in which the fault is detected, keeping the remaining part of the electric system working normally. This allows to easily localize the reason of the fault and restart rapidly the power supply to the non-interested areas. RCBOs can have an adjustable sensitivity, allowing to set the differential current value at which they must intervene. This could be useful in situations in which is necessary a larger sensitivity to the current dispersion, like in environments with a high rick of current shocks. Lot of RCBOs are equipped of visual or sound indicators that detects the operating state of the device. They could indicate is the RCBOs is active if it has been interrupted by a fault or if maintenance is necessary. RCBOs could be installed in an electric panel like individual devices or like a module, in combination with other switches. They can be used to protect specific circuits or the whole home or industrial electrical system.

IEC 61009-1 is applied to the RCBOs and gives a complete technical overview to project, build, and evaluate their differential switches to guarantee the safety of the electric systems and the protection against current leakages. Chapter 9 of the IEC 61009-1 is of particular interest for the usage of the UAPFOR and it is about the test that must been executed on the differential switches, also on RCBOs, to evaluate its conformity. These tests are done to evaluate the performances and safety of devices and could include the following test:

- Insulation voltage test: this test verifies the ability of the RCBO to isolate electric circuits in elevated voltage conditions. Specific voltages are applied between

contacts and insulated components of the RCBO, and the insulation resistance is measured.

- Mechanical resistance test: this test evaluates the resistance of the RCBO to the mechanical stress like shocks, vibrations, and thermal stresses. It checks the capacity of the RCBO to maintain its structural integrity and electrical performance despite the mechanical solicitations.
- Working test: this test verifies the efficiency of the RCBO in stopping the circuit in case of overload or current leakages. A test current is applied to evaluate the response time of the RCBO to open the circuit respecting the specified requirements.
- Current leakage test: this test simulates an earth current leakage and verifies the capacity of the RCBO to detect it and stop the circuit. A leakage current, with a predefined value, is applied and is measured the time of response of the RCBO in opening the circuit.
- Chemical resistance test: this test verifies the resistance of the RCBO to the exposition to chemical common agents or specific agents present in the environment in which the RCBO is installed.

Furthermore, it is worth to notice that the flexibility of the UAPFOR machine because it is used to perform fatigue tests also on other types of products like civil series switches, fuse holders and so on.

Basically, the commonly used norms are: 61008-1 for RCCBs, 61009-1 for RCBOs and 60898-1 for MCBs.

CHAPTER 4

STARTING HARDWARE MACHINE OVERVIEW

4.1 STARTING HARDWARE: ELECTRICAL PART

Electromagnetic fatigue machine, UAPFOR, in Laboratory, has the objective of verifying the maximum number of opening e closing operations for which test pieces can resist without failure (electrical or mechanical). These operations are executed with and without load, opening the switch in different ways like knob, test button, differential current. The machine is managed by a PLC.

This thesis project has been developed starting from the original electrical design of the machine, that are described in this chapter.

For simplicity are explained only the relevant electrical circuit drawing parts and the ones that have been modified during the project. All the others are collected in Appendix A.

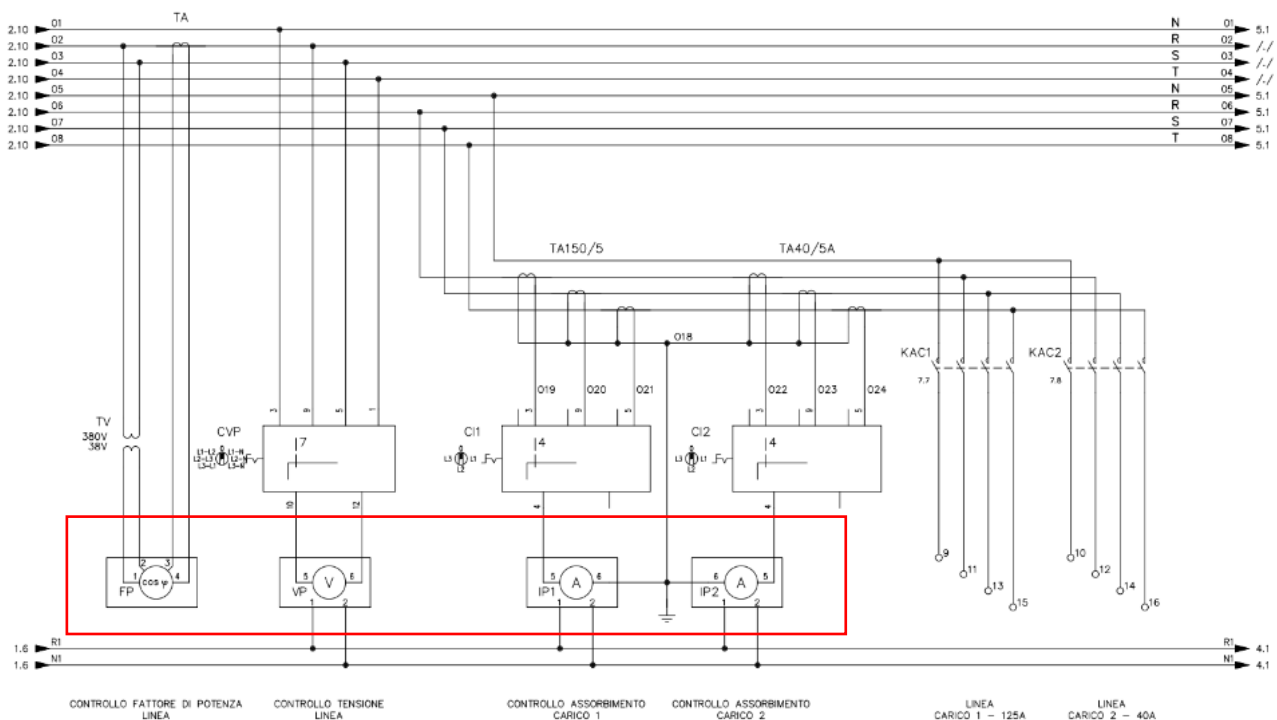

Figure 4.1: Measurement instruments for loads current and voltage.

The first relevant slide is showed in Figure 4.1 where are highlighted in red the measurement instruments that will be modified (see Chapter 6.1).

On the original UAPFOR machine, all the part of measurements relative to loads were shown on displays attached on the machine panel that are: power factor, line voltages L1, L2, L3 and line to line voltages L1-L2, L3-L2, L1-L3 and currents L1, L2, L3 of line load 1 of 150 A and line load 2 of 40 A.

The original design is shown in Figure 4.2.



Figure 4.2: Original measurement displays.

All these values allow to check the current and voltage value that, in the original project, are set using manual switches on a console showed in Figure 4.3.



Figure 4.3: Load switches console

All the circuit behind these switches will be described in Chapter 6, because is part of the new project.

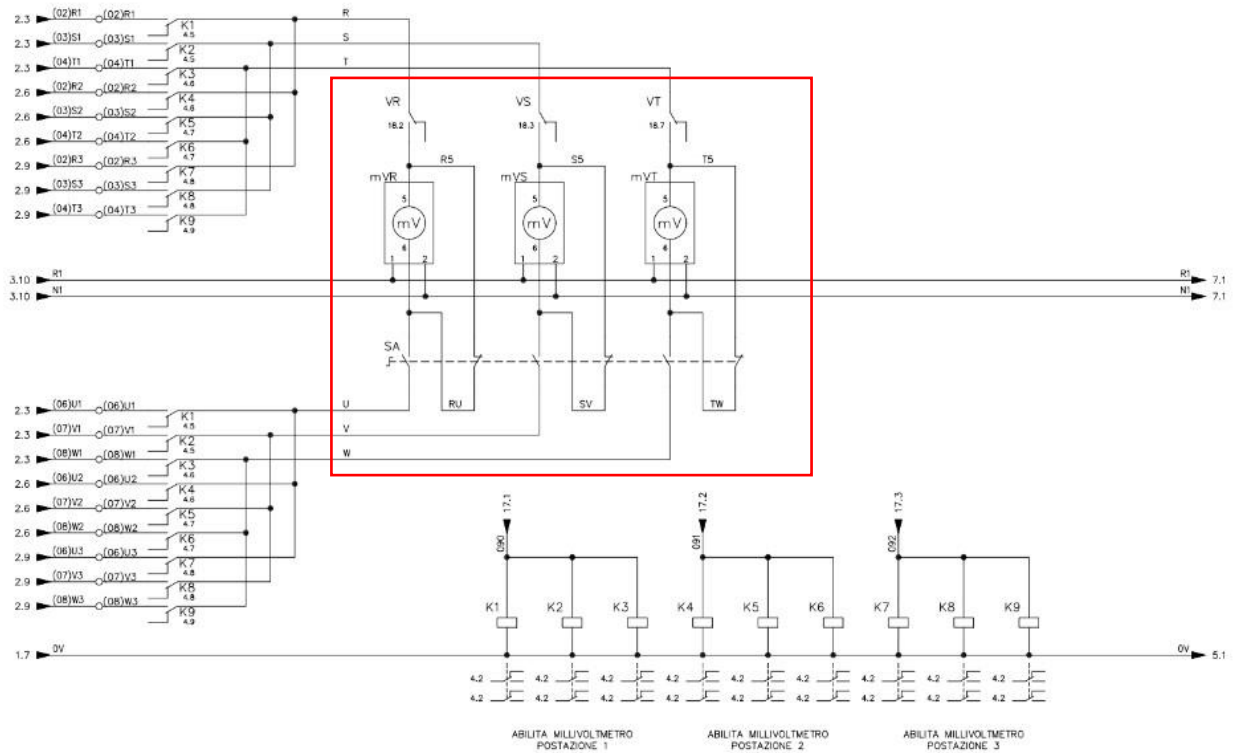

Figure 4.4: Measurement instruments for differential current

Figure 4.4 shows another important slide about measurement instruments that are used to measure the differential current part. Also, these measurements were displayed on displays located on the panel of the machine.



Figure 4.5: Original measurement displays.

These measurement instruments are used to measure the voltage drops on the products under test, the resistance and differential current. Differential current is set using 3 different manual rheostats that are shown in the slide of Figure 4.6.

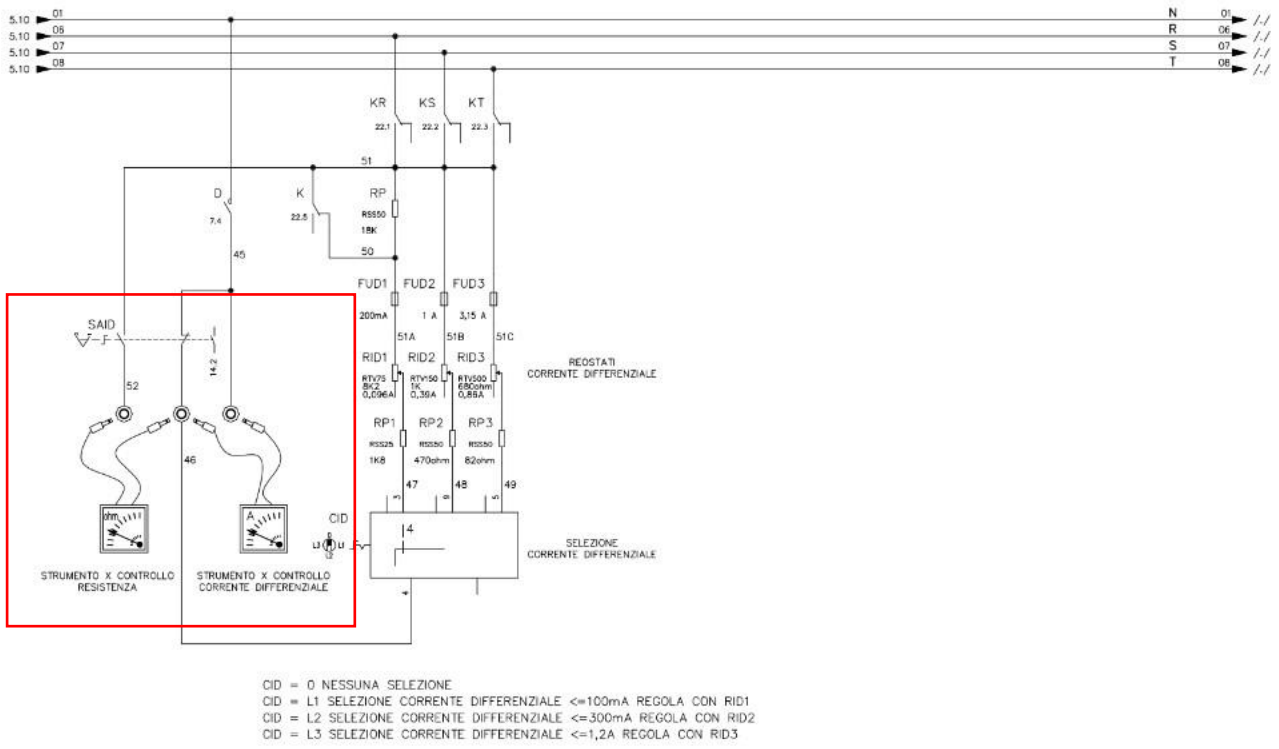

Figure 4.6: Differential current selection

Measures of the resistance and the differential current is done manually using a common tester.

The regulation of the rheostats is done using a table as reference, that is shown is Figure 4.7.

CORR. DIFFERENZIALE		STATO:				
CALCOLO RESISTENZA PER CORRENTE DIFFERENZIALE						
Tensione	V	Corrente	A	Resistenza	Ω	
REGOLAZIONE REOSTATI PER CORRENTE DIFFERENZIALE						
SENSIBILITA'	230V			115V		
	Posizione CID	Posizione scala	Resistenza	Posizione CID	Posizione scala	Resistenza
10 mA	L1 = RID1	60	23K Ω	L1 = RID1	0	11,5 K Ω
30 mA	L1 = RID1	33	7,66 K Ω	L1 = RID1	62	3,83 K Ω
100 mA	L1 = RID1	90	2,3 K Ω	L2 = RID2	20	1,15 K Ω
300 mA	L2 = RID2	70	766 Ω	L2 = RID2	83	383 Ω
500 mA	L3 = RID3	46	460 Ω	L3 = RID3	72	230 Ω
1000 mA	L3 = RID3	78	230 Ω	L3 = RID3	88	115 Ω
2000 mA	L3 = RID3	93	115 Ω	L3 = RID3	96	57 Ω

Figure 4.7: Rheostats settings table

In the electrical part there are also all the I/Os connections that are collected in the ANNEX A.

4.2 STARTING HARDWARE: MECHANICAL PART

For what concerns the mechanical part, the machine is equipped of electro valves that allow the movement of electromechanical pistons to do vertical and horizontal movements using Festo motors.

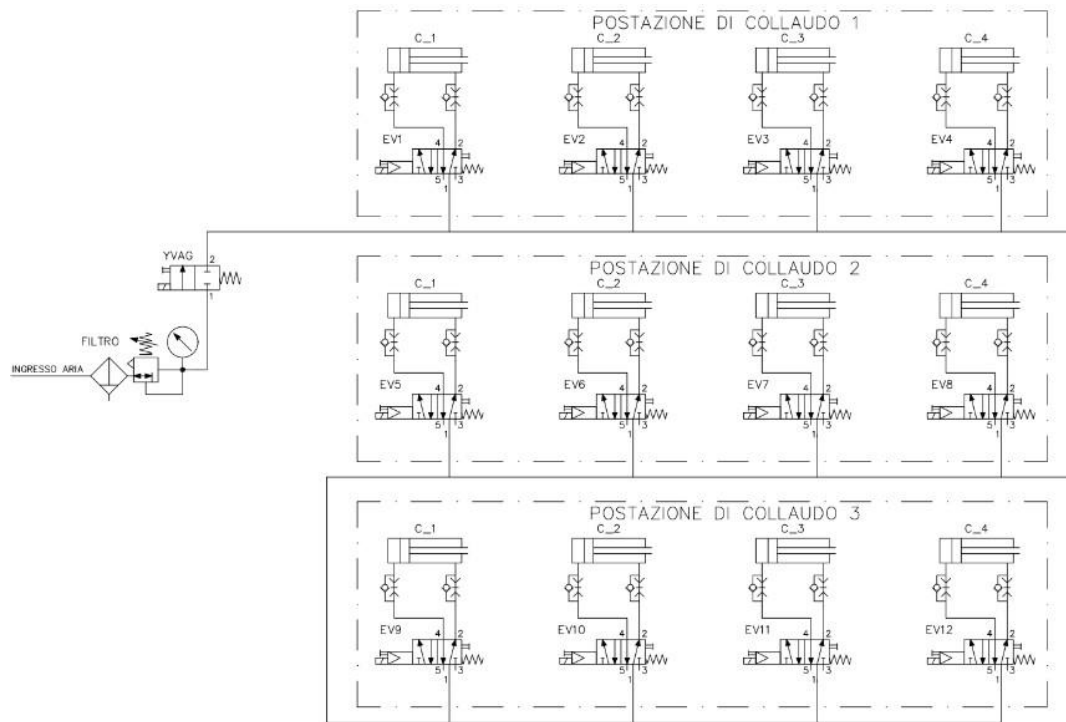

Figure 4.8: Pneumatic circuit

The whole control of the movement of the electro valves is managed by the PLC. Based on the type of test, different end effectors are used. The control logic is explained in the section 4.4 of this chapter.

4.3 STARTING HARDWARE: CONTROL PART

As mentioned before, the control part of the UAPFOR machine is managed by PLC. The original control part architecture of the machine is shown in Figure 4.9.

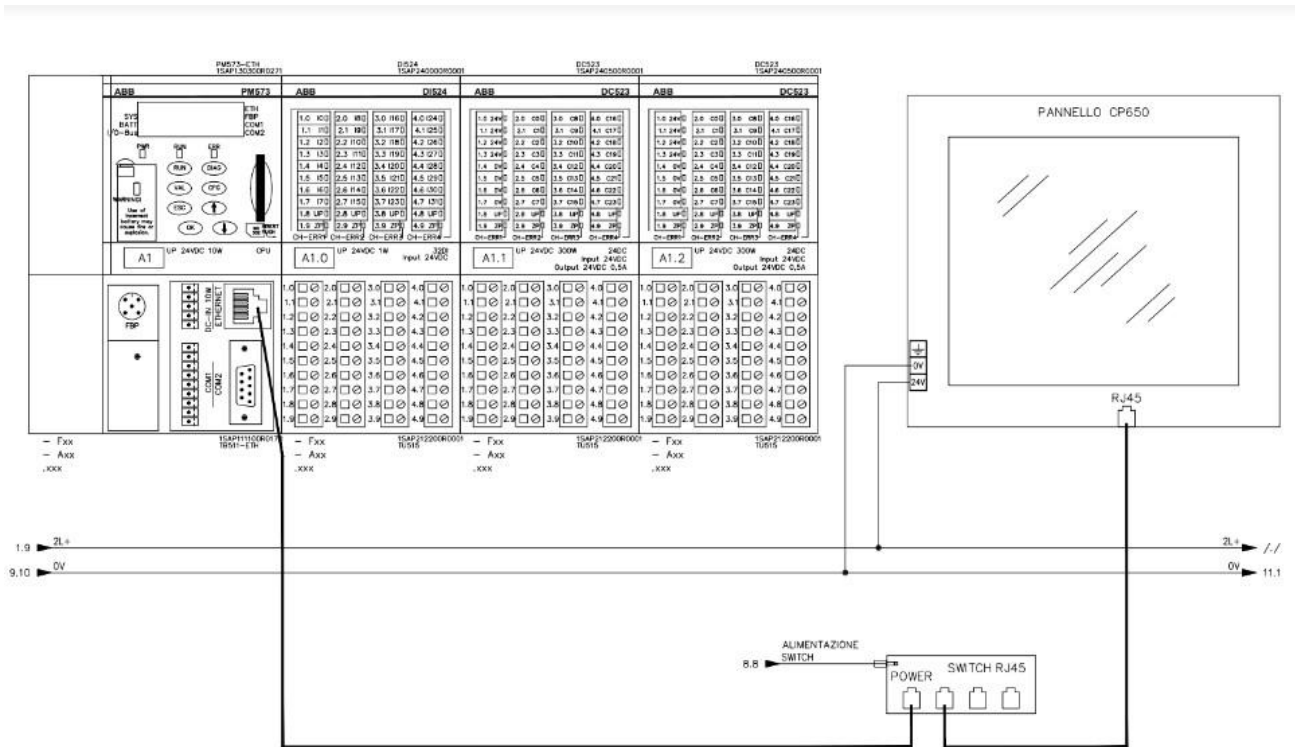

Figure 4.9: PLC AC500 with Panel CP650

The original software is implemented on an operator panel CP650 ABB, that:

- Monitors test operation at every instant of time.
- Set functioning parameters of the machine.
- Shows and archive work recipes.
- Shows the anomalies that are present on the system.
- Selects the manual movements for setting up the test functions.

The PLC that manages the control logic of the machine is the AC500 ABB.

The different operating elements that are present on the front panel can be used to control the devices of the PLC system and to change the operating mode such as:

- Status LEDs: it indicates the availability of devices and components such as communication modules, communication interface modules or function modules. Functionality and diagnosis of the status LEDs depends on the specific module and is described in the device description of the appropriate module. Possible status: ON/OFF/Blinking.

- I/O LEDs: displays the status of the inputs and outputs.
- Display: available for some processor modules. It can be used for simple configurations and for reading out diagnosis information.
- Function keys switches: allow to change the current operating modes/status manually.

The processor module is the PM573-ETH with Ethernet support, one network interface RJ45 or the terminal base. The processor modules are the central units of the control system AC500. The types differ in their performance such as memory size, speed and so on. Each processor module must be mounted on a suitable terminal base. In this case is mounted on the terminal base type TB511-ETH and they differ one from each other depending on the number of communication modules which are used together with the processor module and on the processor module's network interface type (1 Ethernet, 2 Ethernet or ARCNET). Each processor module can operate multiple communication modules through its communication module interface (defined by the terminal base).

The communication modules are mounted on the left side of the processor module on the same terminal base.

On the right side of the processor module, up to 10 digital or analog I/O expansion modules can be connected to the I/O bus. Each I/O module requires a suitable terminal unit depending on the module type. Terminal bases, terminal units, I/O modules, communication modules and accessories have their own technical descriptions.

The processor modules are powered with 24 V DC. AC500 processor modules can be operated with and without memory cards. The processor module uses a standard file system (FAT), and this allows standard card readers to read and write the memory cards. The memory card can be used: to read and write user files, to download a user program, for firmware updates or for program source code storage.



Figure 4.10: Front Panel

Figure 4.10 is a particular representation of the LEDs, display and function keys on the front panel.

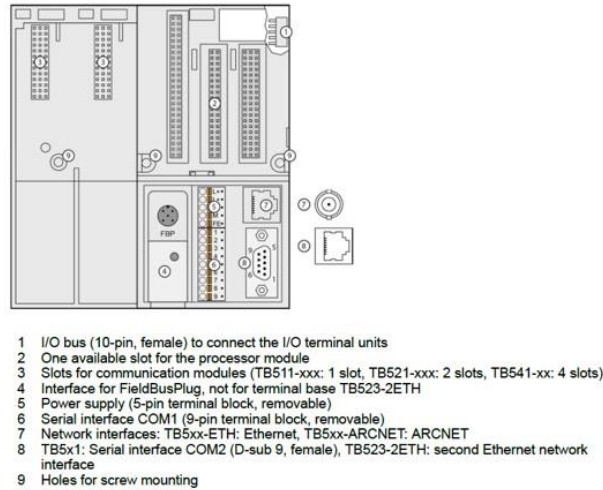

Figure 4.11: Terminal base TB511-ETH

In this picture is depicted in detail the terminal base TB511-ETH composed by 1 processor module, 1 communication module, with network interface Ethernet RJ45.

Terminal bases of type TB5xx are used as sockets for AC500 CPUs and communication modules. Up to 10 I/O terminal units for I/O expansion modules can be added to these terminal bases. The terminal bases have slots for one processor module and for communication modules as well as terminals and interfaces for power supply, expansion, and networking.

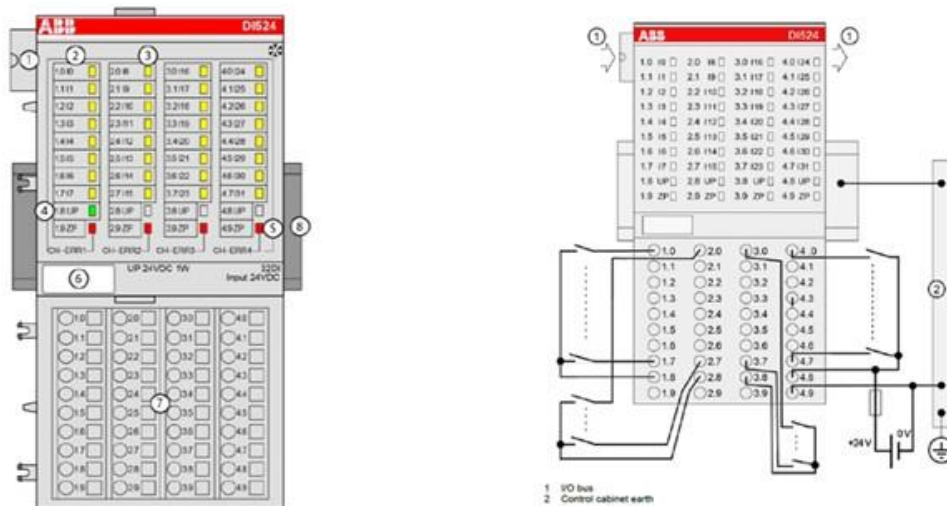

Figure 4.12: Digital Input module DI524

This is a digital input module that allow to acquire input signals coming from external peripherals. Usually, a DI524 module has a predefined number of digital input ports, and each input port could be used to connect a digital signal coming from sensors, switched or buttons.

This device is used as a centralized extension module for AC500 CPUs. Its configuration is performed by software. The modules are supplied with a process supply voltage of a 24 V DC. All available inputs/output are galvanically isolated from all other circuitry of the module. There is no potential separation between the channels within the same group.

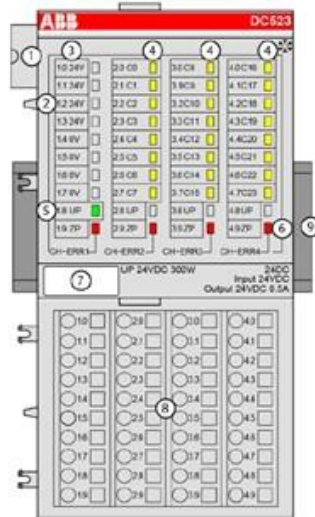

Figure 4.13: Digital Input/Output module DC523

DC523 module is a digital output module that gives digital output signals to external devices. A DC523 module can have a wide number of digital output ports and each one can be used to connect an external device like a relay, an actuator, or a valve. This device can be used as a centralized extension module for AC500 CPUs.

The configuration is performed by software. The modules are supplied with a process supply voltage of 24V DC. All available inputs/outputs are galvanically isolated from all other circuitry of the module. There is no potential separation between the channels within the same group.

Actual PLC logic is managed by ABB Automation Builder software.

CHAPTER 5

STARTING SOFTWARE MACHINE OVERVIEW

5.1 STARTING SOFTWARE

The project is composed by a POU (Program Organization Unit) that is a unit of organization that groups related instructions and logical functions within the program. In ST programming, POUs are used to structure and organize the code in a readable, maintainable, and efficient manner.

There are several types of POUs commonly used in ST programming for PLCs:

- **Function Blocks (FB):** they represent specific functionalities or components of the system. They encapsulate a set of instructions and data, allowing for modular and reusable code. FBs can have input and output variables, and they can be instantiated multiple times in a program.
- **Functions (FUN):** they are like FBs but are not reusable. They contain a set of instructions that perform a specific function. FUNs can have input and output parameters, and they can be called from other parts of the program.
- **Programs (PRG):** they are the main POUs in an ST program for PLCs. They contain the primary control logic of the system. Programs can call FBs and FUNs, and they typically execute in a continuous loop, scanning and updating the system based on input conditions.

POUs can have local variables specific to their scope and can interact with global variables defined in the program. They can be created, modified, and called within the ST program to implement the desired control logic. Using POUs in ST programming for PLCs brings advantages such as modularity, code reuse, ease of debugging, and structured code organization. It enhances the readability, maintainability, and scalability of the program, facilitating system control and troubleshooting.

In a PLC program, data types and libraries play crucial roles in defining the structure, organization, and functionality of the code:

- **Data types:** they define a format and range of values that variables can hold. PLCs typically support various data types such as Boolean, integer, floating-point, string, date/time, and more. Each data type has a specific size and memory representation. It is important to choose appropriate data types based on the nature of the data being processed.
- **Libraries:** they provide predefined code blocks, function blocks, or function modules that can be reused across multiple projects. They offer a way to

modularize and standardize code development, improving efficiency and maintainability.

Then there is the task configuration that refers to the setup and configuration of tasks that control the execution and scheduling of program logic within the PLC. Tasks define the timing and priorities of different program components, such as cyclic program execution, interrupts, and background tasks.

Proper task configuration is essential for achieving desired system performance and responsiveness:

- Cyclic Task: is the main task that executes the program logic in a continuous loop. It defines the scan rate or cycle time at which the PLC program is executed. The cycle time determines how often the program is scanned and updated. It is crucial to select an appropriate cycle time that meets the system requirements, ensuring sufficient time for processing and response.
- Interrupt Tasks: they are used to handle time-critical events or interrupts that require immediate attention. These tasks have higher priorities compared to the cyclic task. Example of interrupt tasks include handling high-priority inputs, alarms, emergency stops, or communication events. Configuring interrupt tasks correctly ensures that critical events are promptly detected and addressed without affecting the normal program execution.
- Background Tasks: they are non-time-critical tasks that run alongside the cyclic and interrupt tasks. These tasks typically handle activities such as data logging, diagnostics, communication protocols, or maintenance routines. Background tasks are assigned lower priorities to avoid interfering with the execution of higher-priority tasks. Careful configuration of background tasks ensures that they don't impact the real-time performance of the control system.
- Task Priorities: assigning appropriate priorities to different tasks is crucial for managing their execution order. Higher-priority tasks take precedence over lower-priority tasks. Priorities determine which task gets access to the CPU first when multiple tasks need to be executed simultaneously. By assigning priorities strategically, you can ensure that time-critical operations are handled promptly while maintain the overall system stability and performance.
- Task Synchronization: in some cases, it may be necessary to synchronize the execution of tasks or coordinate specific actions across different tasks. For example, ensuring that certain actions occur at specific points within the cyclic task or coordinating data exchange between tasks. Configuring task synchronization mechanisms, such as semaphores, flags, or events, allow for controlled and coordinated execution of program logic.

PLC program interfaces with a graphical Human-Machine Interface: is the graphical user interface that allows operators to interact with a PLC system. It

provides a visual representation of the system's status, data, controls, and alarms, facilitating effective communication between humans and machines.

The general structure of the program consists in five folders and seven programs.

- FB_YVP (FB): this function block contains multiple conditional statements that simulate the response of a bistable valve.
- PRG_COMANDO_ATTUATORI (PRG): the program manages the automatic commands for pneumatic actuators and the initialization sequence for sample disarming manoeuvre.
- FC_LogicaAllarmi (FUN): this function manages the alarm logic.
- FB_Clock (FB): this function block manages a clock functionality. It allows users to control the timing of events or synchronize operations based on a specified clock time.
- FB_StepSequencer (FB): this function block manages sequence of operations. It allows for the creation of a sequence consisting of multiple steps, where each step can be associated with a programmable code. This function supports up to 16 steps, and the code for each step can be automatically inserted into the logic. It is useful for managing sequential operations where a defined sequence of steps needs to be followed.
- FC_TimeoutCalc (FUN): this function is responsible for calculating a timeout value based on the given input parameters. It takes two inputs: TimeValSec, which represents the desired time value in seconds, and TimeDivider, which is a divisor used to scale the time value. The function provides an output of type INT, which represents the calculated timeout value in milliseconds. It is used in applications where a timeout value needs to be calculated based on certain criteria. The function ensures that the calculated timeout is appropriately scaled and provides a convenient way to obtain a timeout value in milliseconds, allowing for accurate timing in event-driven scenarios or automation processes.
- FB_CheckCortocircuito (FB): this function block is designed to handle the checking of a short circuit condition. The function block checks the status of the phase connections (PhaseRPiastra, PhaseSPiastra, PhaseNPiastra) and determines if a short circuit is present based on logical conditions. It allows for the monitoring of phase connections, detection of short circuit faults, and appropriate responses such as triggering alarms.
- FB_LogicaBanco (FB): this function block handles control and logic operations related to a bank or group of equipment or processes. It identifies the test type to execute, the workstation in which the test is executing, selects the number of poles to verify the sample, manages the global states for the control logic, calculate the time necessary to disarm the sample and different time control parameters.

- FB_PowerON (FB): this function block manages the sequence of power insertion.
- FC_RCPIInit (FUN): this function manages the recipe parameters initialization to start the system.
- FB_TwoHand_Operation (FB): this function block manages the safety two hand operation.
- PLC_PRG (PRG): this is the main PLC program that manages all the sequence of the program operations.
- PRG_IPI (PRG): this program manages the buttons and simulation input interfaces.
- PRG_IPU (PRG): this program manages the buttons and simulation output interfaces.
- PRG_MANUALI (PRG): this program manages the initialization sequences to manually control the actuators.
- PRG_SFTY (PRG): this program manages the bimanual command for manual commands, the two-hands safety mode.
- PRG_System (PRG): this program manages the clocks activation, alarms, machine reset and other check operations.

Then, different data types are defined for actuators, alarms and warnings, machine, manual commands, recipe, and sequence.

Different libraries are used like the one for the Ethernet communication.

Task configuration is constituted by 6 different tasks:

- CyclicTask PLC_PRG(): it is a cyclic task with priority 10 and a period interval of 25 ms.
- SafetyTask PRG_SFTY(): it is a cyclic task with priority 11 and a period interval of 10 ms.
- IPITask PRG_IPI(): is a cyclic task with priority 11 and a period interval of 25 ms.
- IPUTask PRG_IPU(): is a cyclic task with priority 11 and a period interval of 25 ms.
- ManualiTask PRG_MANUALI(): is a cyclic task with priority 10 and a period interval of 25 ms.

5.2 STARTING HUMAN MACHINE INTERFACE

In the original project the human-machine interface is managed by a panel display ABB CP650 that allow to monitor and control the PLC. It is a Control Panel, 10.4", TFT touch screen, 64K colours, 800x600 pixel. This is equipped of an Ethernet port RJ45, a communication port to connect it to other devices or networks.

On the Panel PC there is the supervision program. The commands element are representations on the control panel display that are sensitive to touch like buttons, data entry fields, warning windows. The operation of these objects does not differ in fact from the mechanical pressure of the keys. Data that could be changed are formed by black text on white background, while only reading data are represented with black or grey background fields. Some commands, furthermore, are protected by an access level. To activate protected objects is necessary to have credential access for the required level.



Figure 5.1: HMI Test Page

The template of each page is subdivided in 3 main parts, described as follow:

- Title bar: is the upper part, highlighted with index number 1, in which is indicated the title bar, which is always present in all the pages, in which there is the title of the shown page, the state of the machine and the system hour.
- Page body: this part is indicated by index 2 and is the central part in which are shown the different section which compose the supervision application.
- Button bar: this part is indicated by index 3, is the lower part in which are present different buttons necessary to access to different pages: test page, recipe,

settings, manuals, alarms. In case there are alarms, the ALLARMI button becomes red.

The page represented in Figure 5.1 is the Test Page, that allows to set test data and to show test data that has been set in the recipe page and to show the behaviour and the results of the test itself. Fields that are not present in the page could be divided in two subgroups based on their usage: editable fields that are independent from the active recipe and are needed to set the test based on the sample characteristics to verify, and non-editable fields that depends on the type of active recipe.



Figure 5.2: Test Page editable fields

In the left side of the page there are the general settings, that are independent from the set recipe. They can be modified only when the machine is not in <Ciclo ON> mode.

The test general settings are described as follow:

- **NUMERO POLI:** setting of the number of poles of the sample to test. Pushing the button + the number of poles can be increase, pushing - button is decreased. The possible selections are 1P, 1P+N, 2P, 3P, 3P+N.
- **FASE CORRENTE DIFFERENZIALE:** setting of the phase in which flows the leakage current for the differential test. Each time in which the button R-S-T is pushed, the setting changes from R to S to T.
- **POSTAZIONE:** enabling test positions. With OFF selection (green led turned off) it is excluded from the automatic cycle. With ON selection (green led turned on) the differential reset is excluded.
- **ESCLUSIONE CONTROLLO:** is possible to disable the continuity check of the poles after the reset during the test. With OFF setting (green led turned off) the control is done. With ON setting (green led turned on) the control in not done.

The right part of the test page is divided in 4 groups that correspond to the test to execute in which apart from the cycle counters there are also the editing fields FERMATA PROGRAMMATA. There, for each type of test, is possible to insert the cycle number corresponding to the one in which the test must be stopped.

In the top section of the page, in the RICETTA ATTIVA field, there is the name of the set recipe in the page RICETTA that is currently uploaded and executed. Near the recipe name is shown a symbol that indicates if the active recipe is of the type “norma” or “custom”.



Simbolo	Tipo ricetta
	Ricetta di tipo “norma”
	Ricetta di tipo “custom”

Figure 5.3: Active recipe type

In the left bottom part of the page are shown the settings that depends on the active recipe.

<p>Ricetta attiva: Custom </p> <p>Numero poli: 1 P+N</p> <p>Fase corrente differenziale: x11</p> <p>Postazione 1: ON OK</p> <p>Postazione 2: ON OK</p> <p>Postazione 3: ON OK</p> <p>Esclusione tempo blocco: ON OK</p> <p>Esclusione controllo: ON OK</p> <p>Tempo tra due cicli: 100.0 Sec</p> <p>Corrente differenziale: 100mA</p> <p>Tempo prove a vuoto: VELOCE</p> <p>Contatori cicli prove eseguiti</p>	<p>1 PROVA A VUOTO IN ESECUZIONE</p> <p>CICLI TOTALI: 4000</p> <p>CICLI OK: P1: 10 P2: 8 P3: 10</p> <p>CICLI KO: P1: 0 P2: 2 P3: 10</p> <p>RIARMII KO: P1: 0 P2: 1 P3: 2</p> <hr/> <p>2 PROVA A CARICO ABILITATA</p> <p>CICLI TOTALI: 500</p> <p>CICLI OK: P1: 0 P2: 0 P3: 0</p> <p>CICLI KO: P1: 0 P2: 0 P3: 0</p> <p>RIARMII KO: P1: 0 P2: 0 P3: 0</p> <hr/> <p>3 PROVA TASTO DI TEST ABILITATA</p> <p>CICLI TOTALI: 1000</p> <p>CICLI OK: P1: 0 P2: 0 P3: 0</p> <p>CICLI KO: P1: 0 P2: 0 P3: 0</p> <p>RIARMII KO: P1: 0 P2: 0 P3: 0</p> <hr/> <p>4 PROVA DIFFERENZIALE DISABILITATA</p> <p>CICLI TOTALI: 0</p> <p>CICLI OK: P1: 0 P2: 0 P3: 0</p> <p>CICLI KO: P1: 0 P2: 0 P3: 0</p> <p>RIARMII KO: P1: 0 P2: 0 P3: 0</p>
---	--

Figure 5.4: Active recipe settings

- TEMPO TRA DUE CICLI: is shown the set time between one test and another. If the active recipe is of type “norma” it could be DT30 or DT15, while if the active recipe is of type “custom” it is a numeric value expressed in seconds.
- CORRENTE DIFFERENZIALE: shows the step of the differential current that has been set in the active recipe and can be 10mA or 100mA.
- TEMPO PROVE A VUOTO: for the active recipe of type “norma”, it displays the time between reset and sample release in no-load tests and can be NORMALE or VELOCE. If the active recipe is of type “custom”, the field is

hidden because in this case is not fixed as per standard but can be customized in the recipe data.

The right part of the test page is divided in 4 groups that corresponds to the test to do:

- 1) un-load test;
- 2) load test;
- 3) test button;
- 4) differential current test.

In each section, in addition to the editable fields FERMATA PROGRAMMATA already described before, there are shown the following information: number and test name, test state, total number of cycles, number of done cycles and KO cycles.

numero prova	nome prova	stato prova				
1	PROVA VUOTO	IN ESECUZIONE				
FERMATA PROGRAMMATA			10			
CICLI TOTALI			4000			
CICLI OK	P1	10	P2	8	P3	10
CICLI KO	P1	0	P2	2	P3	10
RIARMIO KO	P1	0	P2	1	P3	2

Figure 5.5: Info FERMATA PROGRAMMATA section

The test state changes depending on the recipe settings and based on the test state itself during the test.

In the following are indicated all the possible states and their meanings:

- DISABILITATA: test disabled by recipe.
- ABILITATA: test enabled by recipe but not in running state.
- IN ESECUZIONE: test enabled by recipe and in running state.
- HOLD: test enabled by recipe, and during the execution is pushed the hardware button HOLD or the test is in scheduling stop.

Counter cycles show the test progress:

- CICLI OK: shows the number of cycles done until that time for each test and for each test workstation until reaching the ones that are set in the recipe.
- CICLI KO: shows the number of cycles in which the continuity test is failed for each test and for each test workstation.

Cycle counters shows the progress in time of the test:

- CICLI OK: shows the number of cycles done until that time for each test and for each test workstation until reaching the number of cycles set by the recipe.
- CICLI KO: shows the number of cycles in which the continuity test of the phases fails per each test and per each test workstation.

- RIARMI KO: shows the number of failed resets per each test and per each test workstation.

In the left bottom section of the test page there is the button to reset the counters.

Pushing the RESET CONTATORI button is possible to turn to 0 the counters CICLI OK, CICLI KO, RIARMI KO relatives to all the tests and all the test workstations.



Figure 5.6: Button

This button is not active during the machine state of CICLO ON.

The recipe page allows to compile, save, and activate the recipes that determine the modalities of execution of the test cycles. Configurable recipes are of two different types, “norma” or “custom” and are located into two different archives memorized in the operator panel.

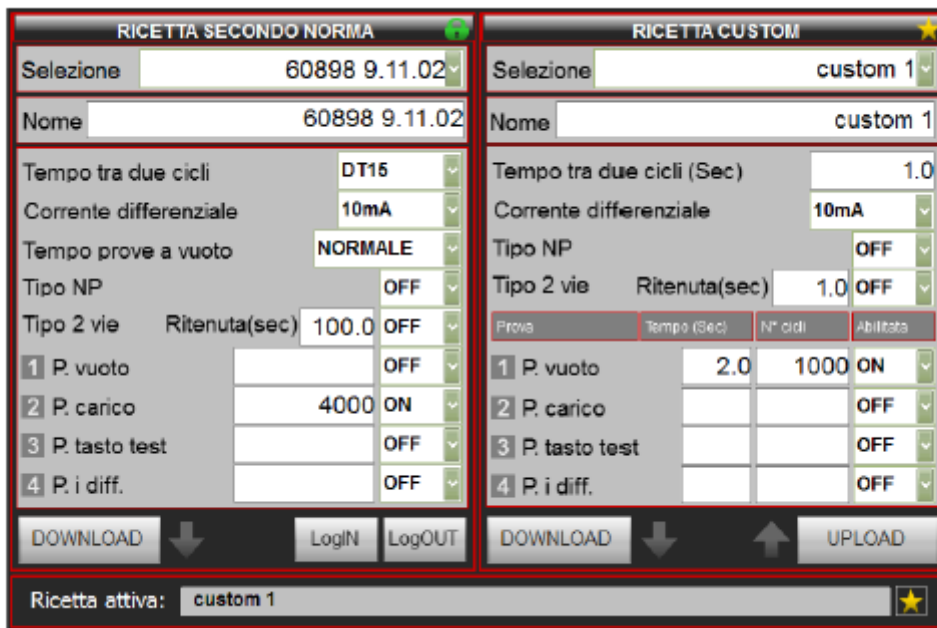

Figure 5.7: HMI Recipe Page

Each archive recipe is composed by a set of 100 data said recipes which contains, each one, the own series of parameters that could be inserted and are called elements. Data set or recipes are already present in the archive with a name that goes from Set0 to Set99, and the content of their elements is empty at the beginning. To save a new recipe, recall the desired data set, through the dropdown list SELEZIONE: modifying the content of the elements, they are instantaneously saved in the panel without the need to confirm. Modifying the field NORME RICETTA it is instantaneously changed in the dropdown list SELEZIONE.

The page is subdivided in 3 groups in which in the left one there are the “norma” recipe configuration fields, in the right one there are the “custom” recipe configuration fields and at the bottom there is the name of the active recipe at that moment.

When a recipe is recalled, both of type “norma” or “custom” through the dropdown list SELEZIONE, it is not yet in working state because data inside their elements are still in the operator panel. To let it in working state is necessary activate it through the DOWNLOAD button, sending data in the PLC memory in which they will remain unchanged until the next recipe activation. If the showed recipe is modified after being activated, to let working the modifications is necessary to active again it through the button DOWNLOAD.

The duplication operation is allowed only for type “custom” recipes, starting from an already existing recipe both of type “custom” or “norma”.

To duplicate a recipe:

- 1) Select a recipe of type “norma” or type “custom” to duplicate through a dropdown list SELEZIONE.
- 2) Activate the recipe through the button DOWNLOAD, data contained in it are uploaded in the PLC.
- 3) In the dropdown list SELEZIONE of the “custom” recipe archive selects the recipe to rewrite.
- 4) Pushing the button UPLOAD, recipe data present in the PLC are copied in the operator panel and previous values contained in the recipe are rewritten.
- 5) If needed, modify the data set name just copied in the field NOME in the “custom” recipe archive.

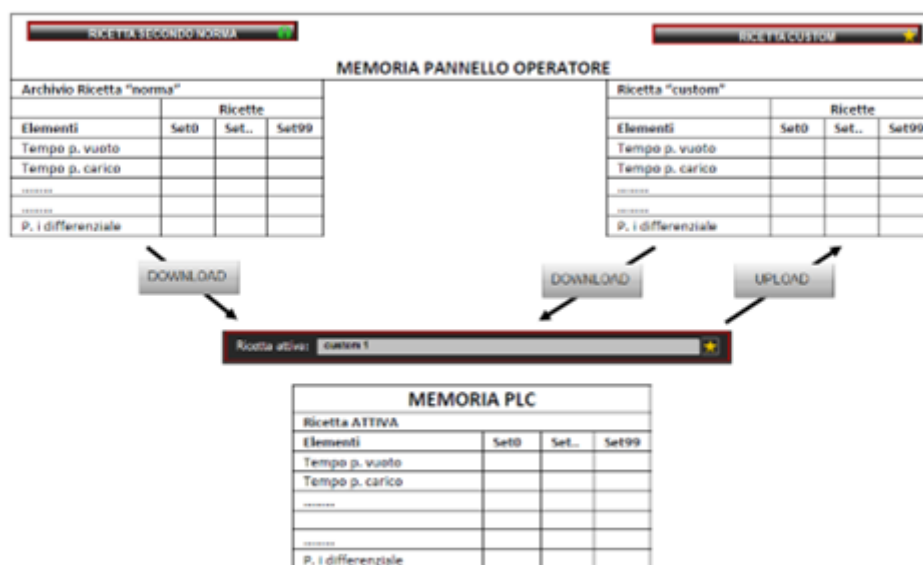

Figure 5.8: Recipe duplication procedure

The “norma” recipe archive is reserved to the recipes which parameters are obtained by the product standards. Once compiled and saved with the respective standard number, they can be recalled by the dropdown list SELEZIONE and activated holding the button DOWNLOAD.

To edit “norma” recipe data is necessary doing firstly the log-in inserting the user and password through the button LOGIN.

- SELEZIONE: select the name of the recipe to display or modify the content of the elements (dropdown list).
- NOME: name to assign to the recipe and that is shown in the dropdown list SELEZIONE (alphanumeric field).
- TEMPO TRA DUE CICLI: selection of the arming time and disarmament time of the sample (DT30/DT15).
- CORRENTE DIFFERENZIALE: selection of the branch of the circuit to differential current operation (10Ma/100mA).
- TEMPO PROVE A VUOTO: selection of the time between arming and release of un-loaded tests (FAST/NORMAL).
- TIPO NP: selection sample type with passing neutral (ON/OFF).
- TIPO 2 VIE: setting of the keeping test in sec. of the sample 2 ways type (numeric field in sec).
- 1 P. A VUOTO: setting of the cycle number and enabling of the un-loaded test (numeric field (n°) ON/OFF).
- 2 P. A CARICO: setting of the cycle number and enabling of the loaded test (numeric field (n°) ON/OFF).
- 3 P. TASTO TEST: setting of the cycle number and enabling test button test (numeric field (n°) ON/OFF).
- 4 P. i DIFFERENZIALE: setting of the number of cycles and enabling the test with differential current (numeric field (n°) ON/OFF).

CHAPTER 6

REVAMPED MACHINE

6.1 HARDWARE MODIFICATIONS: ELECTRICAL PART

First modification involves the part depicted in Figure 4.1 in which the contacts for checking the power factor value, line voltages and load current for lines L1, L2, L3 are now connected to an M4M that has been installed on the rear panel of the machine, near the PLC. For this reason, also all the displays that were used to show these values are not present anymore and all the measurements are shown via HMI.

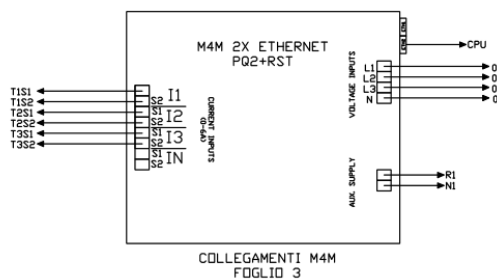

Figure 6.1: M4M

Second modification involves the part shown in Figure 4.4 in which are depicted 3 millivoltmeters to measure voltage drops across the piece under test. On the new machine these connections have been modified and connected to a DMM6500 Keithley that has been installed on the right part of the machine thanks to a metal support.

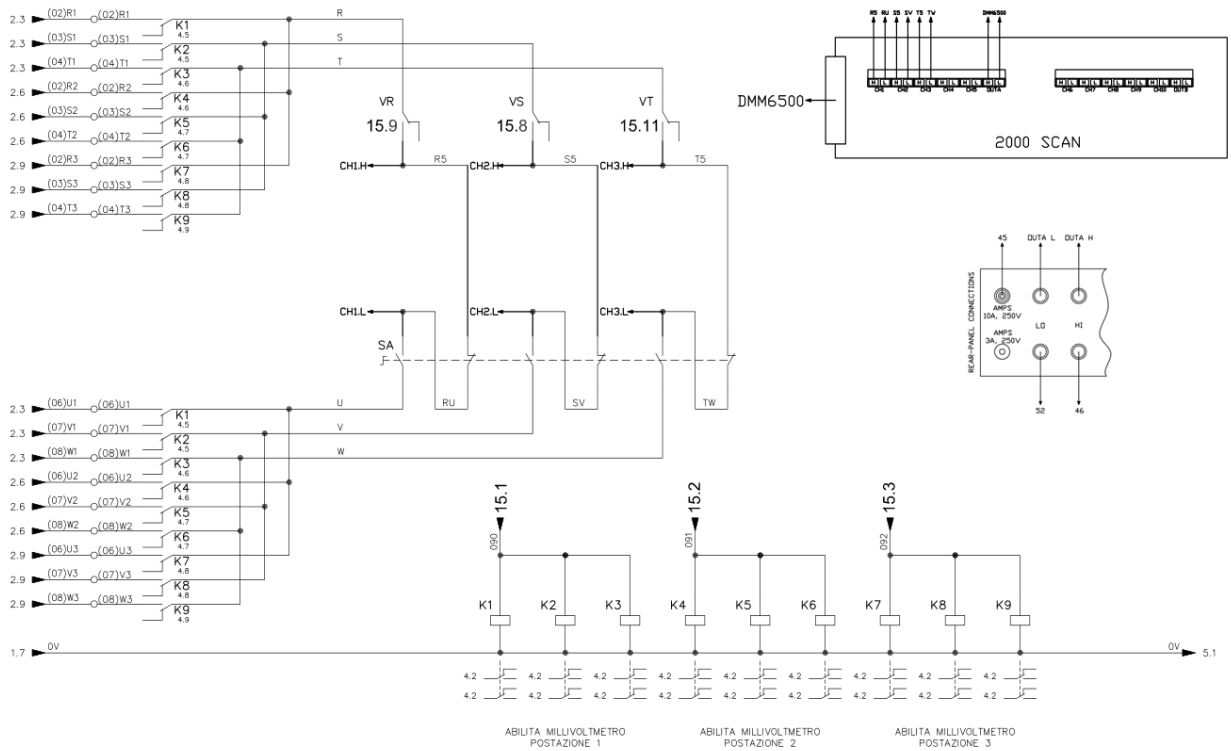

Figure 6.2: Keithley connections for voltage drops measurements.

Third modification involves the part shown in Figure 4.6 for measuring the differential current and the resistance that is selected by 3 different rheostats. The part that concerns the resistance selection is the same as before, but in the old machine all the measures related to the differential current were made by hand using a tester. In the new machine this part has been connected always to the DMM6500 Keithley.

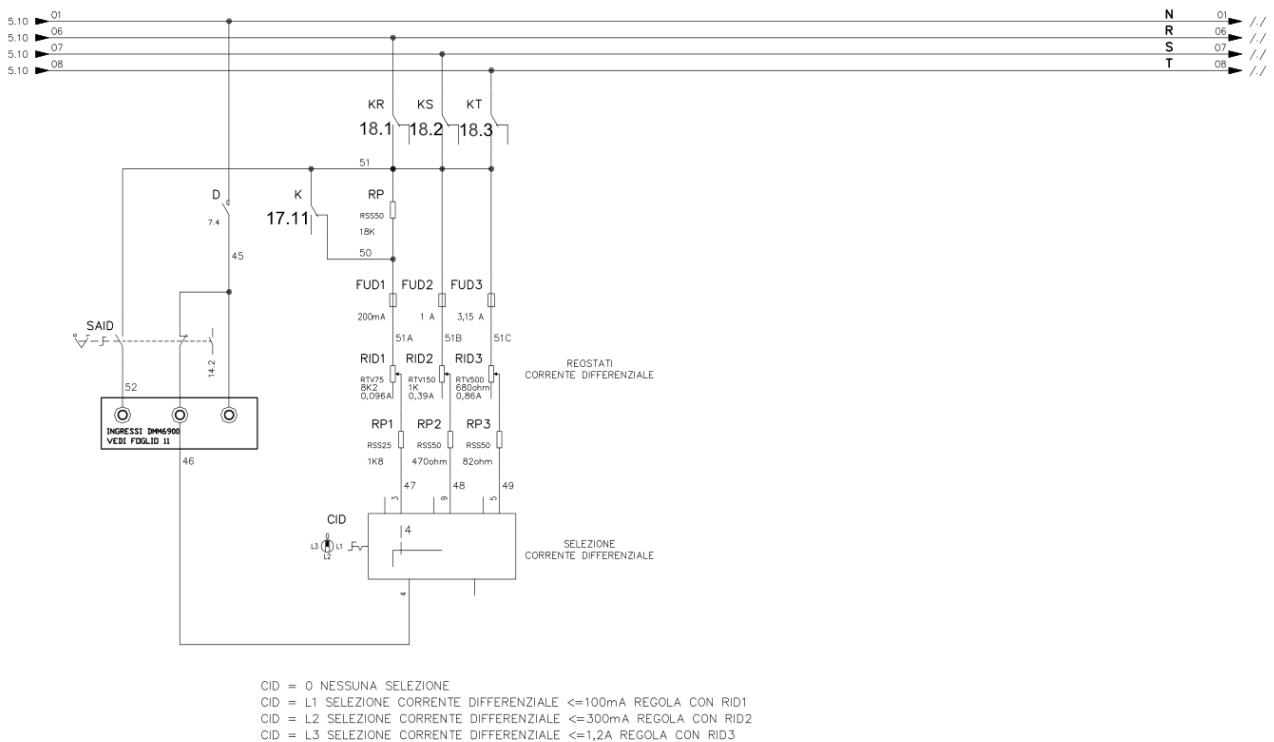

Figure 6.3: Keithley connections for differential current and resistance measurements
 In fact, in the DMM6500 has been mounted a card 2000-SCAN to have multiple channels and consequently multiple measurements in real time.

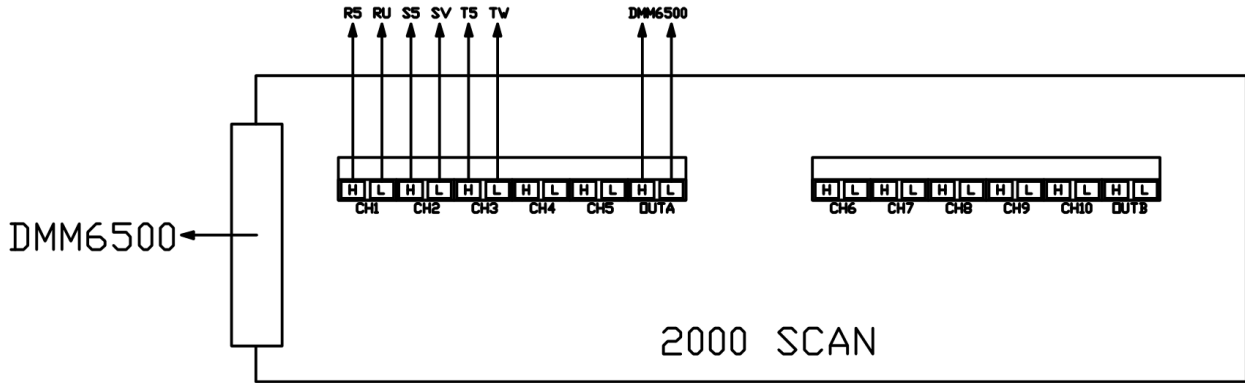

Figure 6.4: 2000-SCAN connections

Fourth modification is related to the whole part that concerns the I/Os of the PLC that are shown in ANNEX C. In this annex is shown the completely new part that is related to the second PLC module that has been in correspondence of the loads circuit. In the new machine, in fact, the selection of loads resistances and inductances is completely automatized.

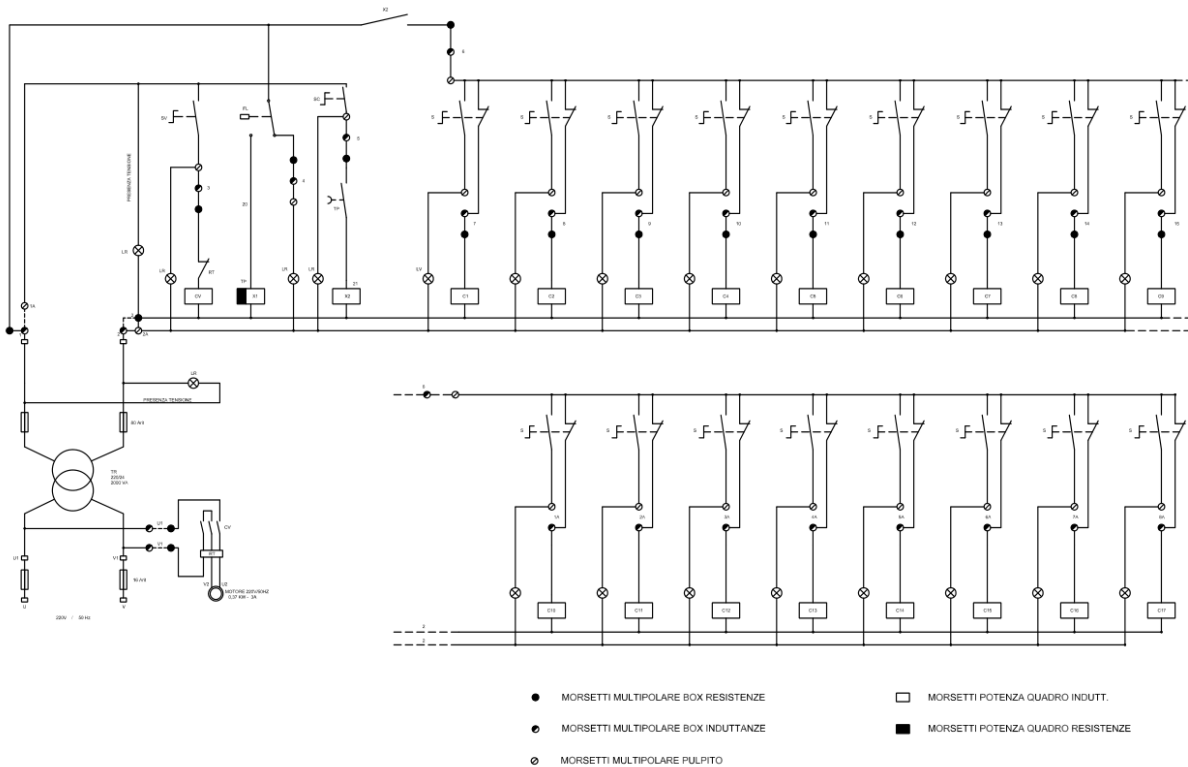

Figure 6.5: Loads circuit.

6.2 HARDWARE MODIFICATIONS: CONTROL PART

The first modification regards the main control panel of the machine. The control panel has different functions: supervision, parameter setting and control of the machine process, but all the operations like the activation of the test cycles and the movement functions are available exclusively via buttons and selectors installed on the on-board control panel machine. The functions implemented via the control panel allow you to carry out: reset operations, movement of the machine's actuators, selection of the operating modes, activate/stop the programmed test cycles in automatic mode. On the control panel are present also some light signals to indicate some conditions that are not managed through the HMI interface which require attention from the operators.

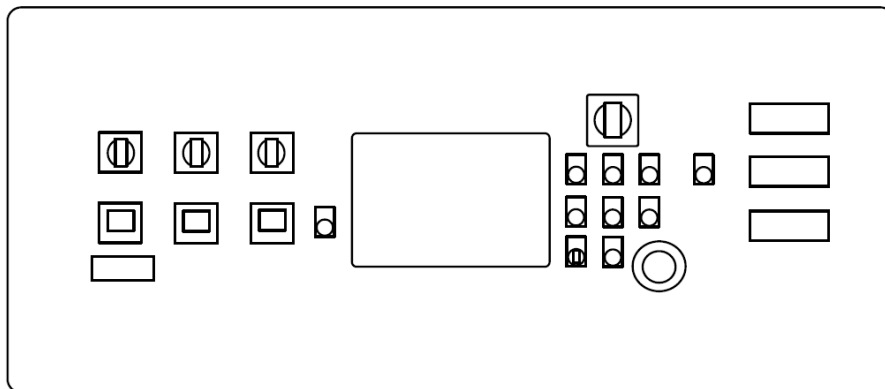

Figure 6.6: Old machine panel drawing

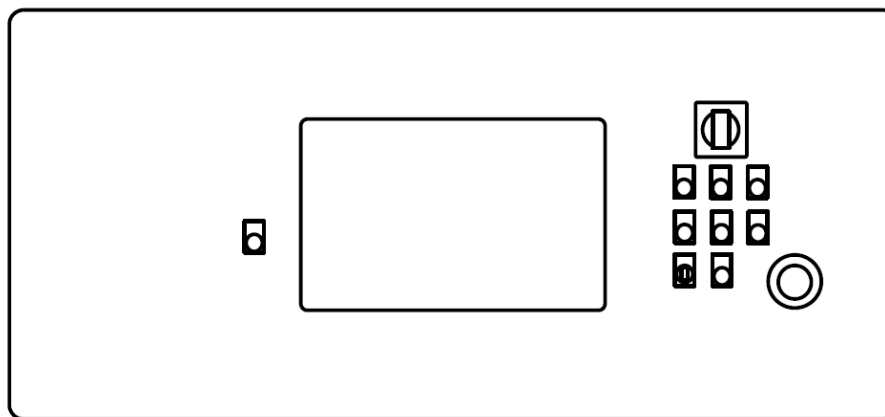

Figure 6.7: New machine panel drawing

In figure 6.6 and 6.7 there is a comparison between the old and new panel of the machine. As is possible to see there are less buttons, but all the ones related to START, HOLD, STOP operations are always present for safety reasons.

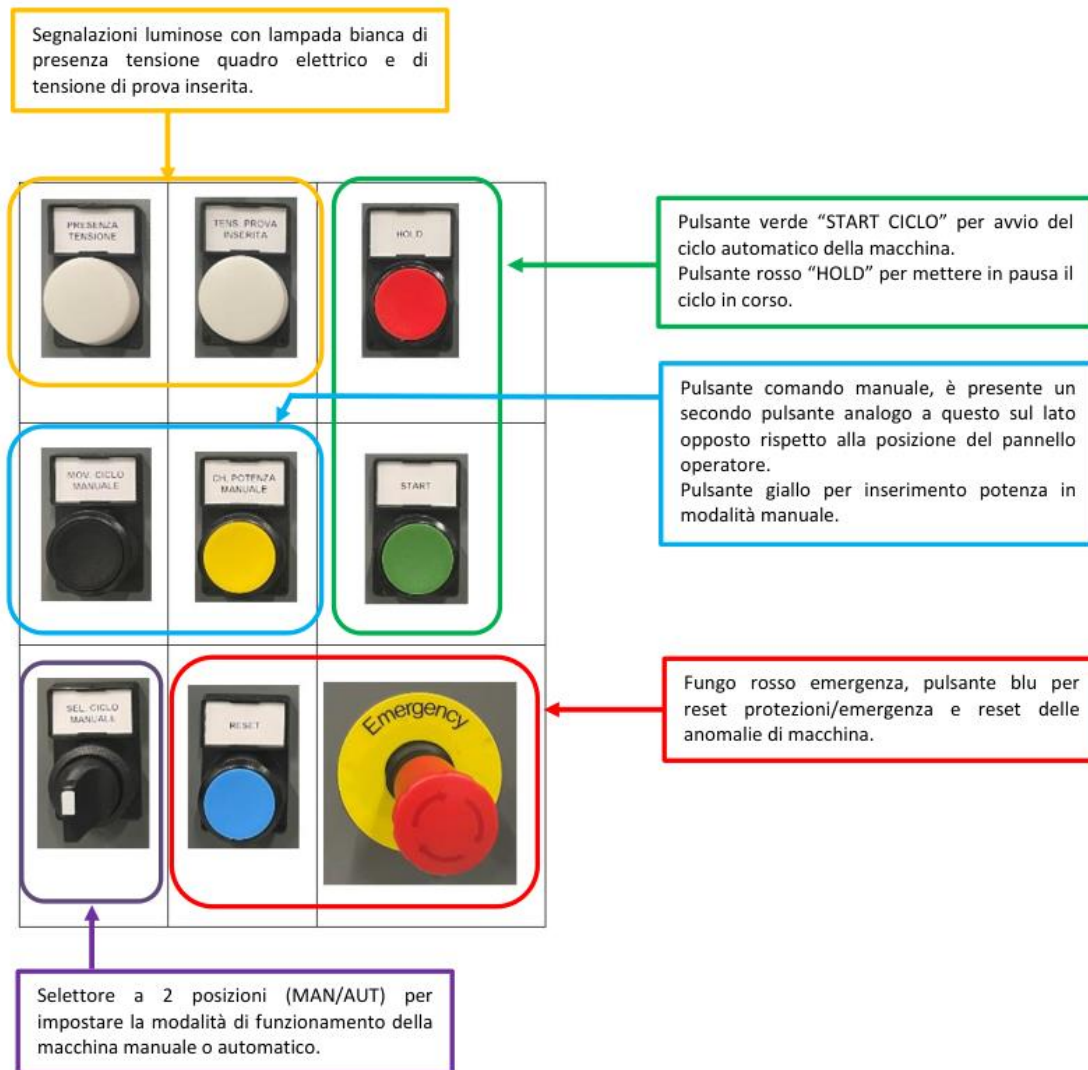

Figure 6.8: Uapfor machine panel buttons

All the buttons present on the actual panel of the machine are described in Figure 6.8.

The hardware part concerning the control panel, PLC, I/O modules, and HMI panel has been completely replaced. The new project in fact involves the use of an industrial PC, two separate I/O blocks connected via POWERLINK and a Panel PC for the implementation of the new user interface using B&R Automation components. A totally new hardware part has been chosen for what concerns the measurement field. An M4M 2X ETHERNET PQ2+RTS has been chosen to measure the current and voltage for the load part and a Keithley DMM6500 6.5 Digit Multimeter with Graphical Touchscreen has been chosen to measure the current and voltage drop on the piece to test. The whole physical control panel that concerns the load selection has been substituted with virtual switches that can be selected through HMI interface.

All the modifications will be explained in a more detailed way in the following.

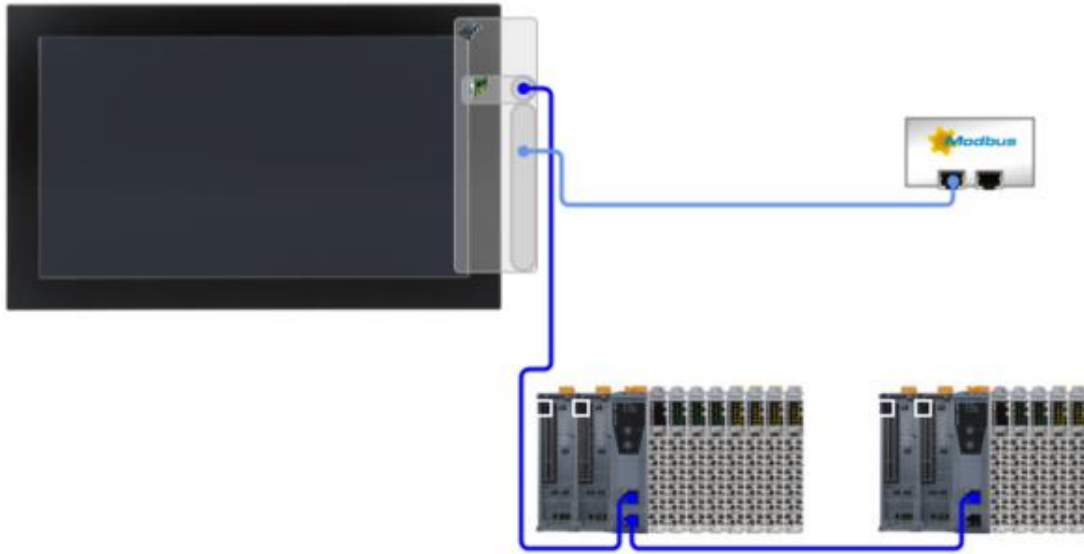

Figure 6.9: Hardware architecture in Automation Studio

In Figure 6.9 is shown all the new hardware part that involves an Automation Panel PC with a CPU and two PLC modules with two different bus controllers of the X20 series of B&R Automation. This is the architecture built in the Automation Studio simulation environment.

For what concerns the PLC point of view, it has been replaced with a B&R Panel PC900 that allow to have both a Windows and Automation Runtime partition and the whole project is managed using the B&R Hypervisor. The whole description of the software will be reported in the next section.

The new I/O's architecture consist into two different modules, connected via POWERLINK to the PC; one is located near the load circuits, located on the upper floor, and another one on board of the machine itself.

6.3 SOFTWARE MODIFICATIONS

The first difference about the software is the implementation of the PLC program on a different software. Instead of using Automation Builder, ABB software, it has been used the B&R Automation Studio software. Because of the fact that the code was old, it has been necessary to change its structure, so to upgrade it in such a way to adapt it to a new and more complex software.

Furthermore, it has been added a completely new part concerning the control logic of the loads because it has been implemented an automatic control system to manage the opening and closing manoeuvres of resistance and inductance contacts of the load circuit. It has been added also all the code part that concerns the management of the recipes and alarms, because in Automation Studio they are managed using mappServices.

All the HMI has been completely modified with respect from the previous one to make it more intuitive, with less pages and with more automatic functionalities to allow the operator to work in an easier way.



Figure 6.12: Home Page

From the Home Page is possible to monitor the status of all the tests like: PROVA A VUOTO, PROVA TASTO TEST, PROVA A CARICO, PROVA I DIFFERENZIALE. The Donut Chart widgets display the number of done cycles and to do cycles per each test. Numeric Output widgets display the number of KO cycles and KO rearmaments. Numeric Input widget FERMATA PROGRAMMATA allow to insert the number correspondent to the stopping cycle number, it is a programmed stop. On the bottom there is the button RESET CONTATORI to put to zero all the counters of all the tests.

On the right side of the page is possible to visualize if the machine is in AUTOMATIC or MANUAL state if there is an alarm (ANOMALIA) or the test is in running state (Ciclo ON) and the status of the loads circuit clicking on the button VISUALIZZA (Figure 6.13).

It is also possible to visualize in real-time all the M4M measurements relative to the tests under load like currents, power factor and line voltages.

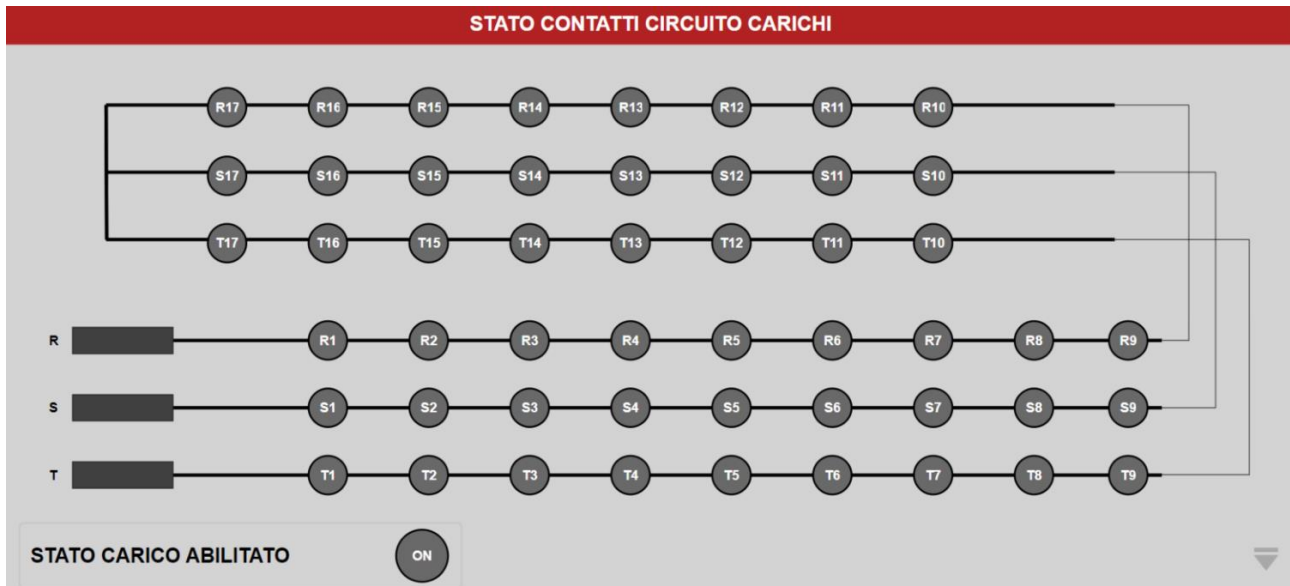

Figure 6.13: Loads circuit status.

Figure 6.13 shows the status of all the contacts that correspond to each resistance and inductance of the loads circuit and the status of the load if it is enabled or disabled. When the load is enabled, the current flows if the load is enabled also through a switch located on the front panel of the machine. Furthermore, the current will flow through the piece under test only if the power is activated on the machine station where the piece under test is mounted. The activation of the power can be done manually, by pressing the button CHIUSURA POTENZA located on the front panel of the machine or automatically when the automatic mode is selected. The automatic mode can be selected using a selector, CICLO MANUALE, located on the front panel of the machine.

ELSB ABB VITTUONE **CONTROLLO ALLARMI** **ABB**

STATO: **Manuale** Anomalia **BATT.**

ALLARME CORRENTE STORICO ALLARMI

Ordina Filtra Riconosci Riconosci tutto

Data e ora	Messaggio Allarme	Stato	Informazioni aggiuntive
2024-03-25 12:20	INTERVENTO EMERGENZA, DISARMARE EMERGENZA E PREMERE TASTO RESET		
2024-03-25 12:20	PROTEZIONI APERTE, CHIUDERE PROTEZIONI E PREMERE TASTO RESET		

HOME CONFIGURA PROVE IMPOSTA CARICHI IMPOSTAZIONI

Figure 6.14: Alarm Page

In the Alarm Page are shown all the Alarm status. This page can be opened by clicking on **CONTROLLO ALLARMI** in the Top Content that is fixed in each page. The label **CONTROLLO ALLARMI** is visible only in case of anomalies. The Alarm Page allow to understand which is the cause of the anomaly. When the alarm is solved, is possible to acknowledge it or all of them. It is also possible to see the history of all the alarms pressing on **STORICO ALLARMI**. When all the alarms are solved, it will be possible to start the cycle or to move the cylinders manually. Each alarm contains its description under the section **Messaggio Allarme**.

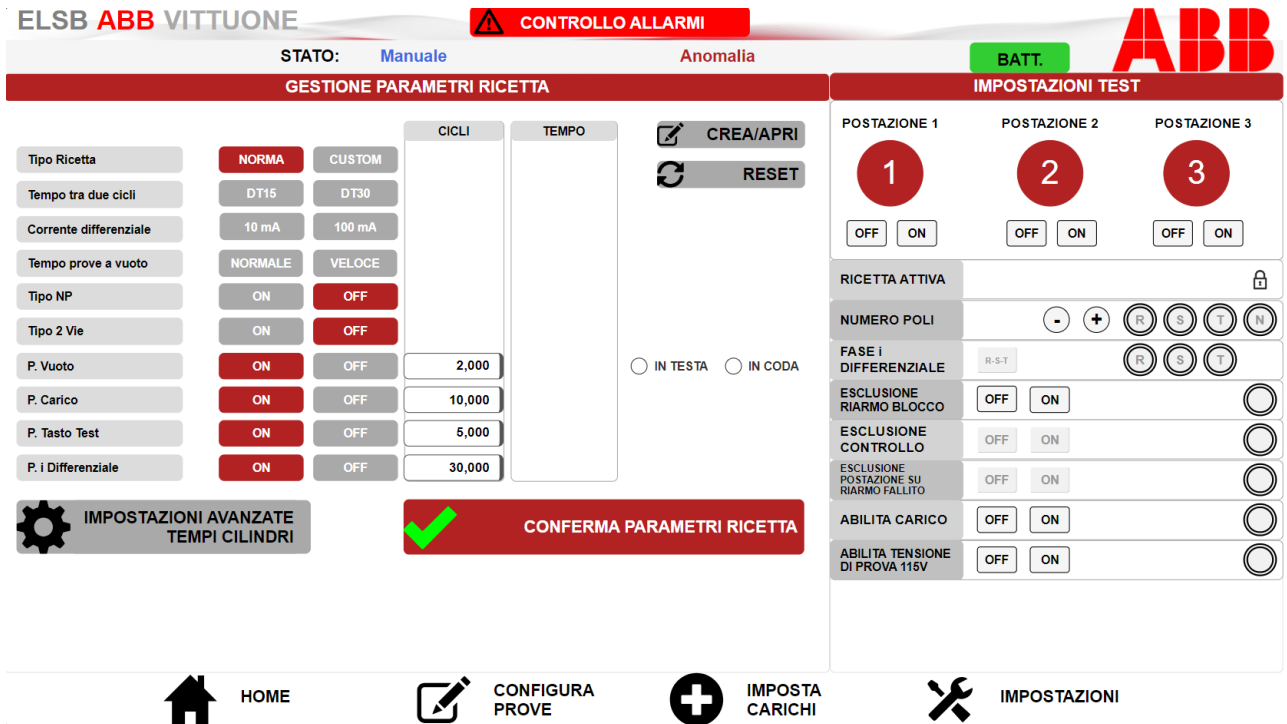

Figure 6.15: Test Configuration Page

Test Configuration Page allow to configure the tests by selecting all the parameters of the recipe. After selecting the recipe type, test types and so on, it is possible to save all the parameters by clicking on **CONFERMA PARAMETRI RICETTA**. On the right part there are all the settings to complete the configuration of the test like the enabling or disabling of each station, the selection of the number of poles and so on. Is worth to notice that some parameters are mandatory to start the test, in fact, if one of the mandatory parameters is not set it will not be possible to start the cycle of tests and there will be almost an alarm showed in **CONTROLLO ALLARMI** page.

This page represents one of the main differences with the previous HMI because in only one page it is now possible to configure the recipe parameters, the test settings, manual maneuvers, and cylinder times. It is also possible to enable the load directly by this page.

This is an important result because configuring a test with this new HMI is easier and more intuitive.

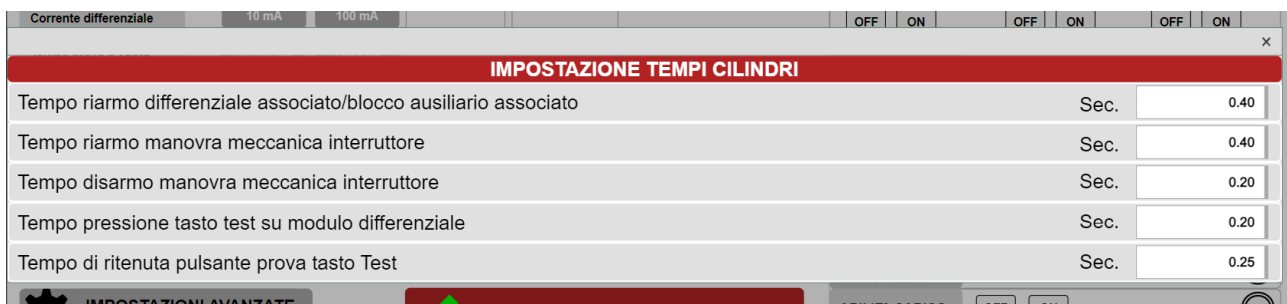

Figure 6.16: Cylinders times setting.

Clicking on IMPOSTAZIONI AVANZATE TEMPI CILINDRI is possible to set all the times relatives to cylinders movements.

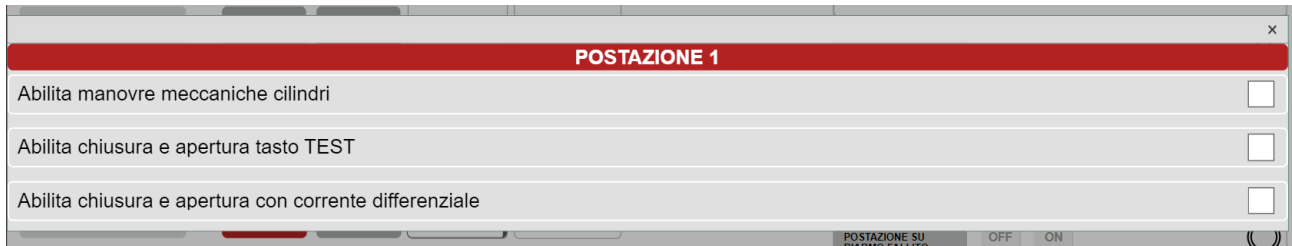

Figure 6.17: Enabling manual maneuvers.

If the machine is set on MANUAL, clicking on ON to enable the station will open the dialog in which is possible to enable the manual movement of the cylinders for the same station. If, instead, the machine is set on AUTOMATIC it will be possible to switch ON or OFF the station only.

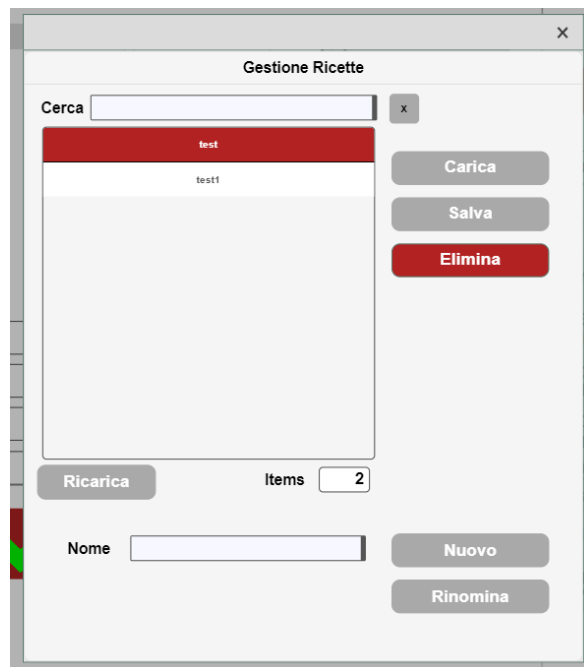

Figure 6.18: Recipes Management

By clicking on CREA/APRI button, in the section related to the management of the recipe, a dialog will be open in which it is possible to visualize the folder containing all the recipe files with the possibility to upload an already existing recipe, save a new recipe with a custom name and eliminate a recipe file.



Figure 6.19: Loads Setting

In Figure 6.19 is shown the page for the configuration of loads circuit. It is divided in two sections. On the left side there is the area related to the automatic configuration of the resistances and inductances to select given a desired value of the current. Following the listed steps, it will be possible to do a test in which are saved the parameters of line voltages, power factor and currents measured by the M4M. All the values are then shown in the dialog that will be open clicking on VISUALIZZA RISULTATI (Figure 6.21). Before starting the test, some parameters must be configured clicking on SET PARAMETRI (Figure 6.20).

Is important to highlight that not all the buttons are visible and enabled if the check list is not completely verified. In Figure 6.19 all the buttons are visible and enabled for explanation.

On the right side there is the area related to the manual configuration of the contacts corresponding to resistances and inductances to switch ON or OFF, the enabling of the load and of the valve. This area has the same purpose of the physical control panel that was present in the previous machine project. To help the user in doing the calculations, also in the manual case is possible to check the values of the total resistance and total inductance (in Settings, Figure 6.22, is present the table TABELLA IMPOSTAZIONE CORRENTE CARICHI in which are listed the values of the total resistance and total inductance to set to obtain a desired value of current).



Figure 6.20: Settings for automatic test for loads setting

In Figure 6.20 is shown the dialog that is opened when clicking on SET PARAMETRI to choose the desired working station, the number of poles and enabling the load.

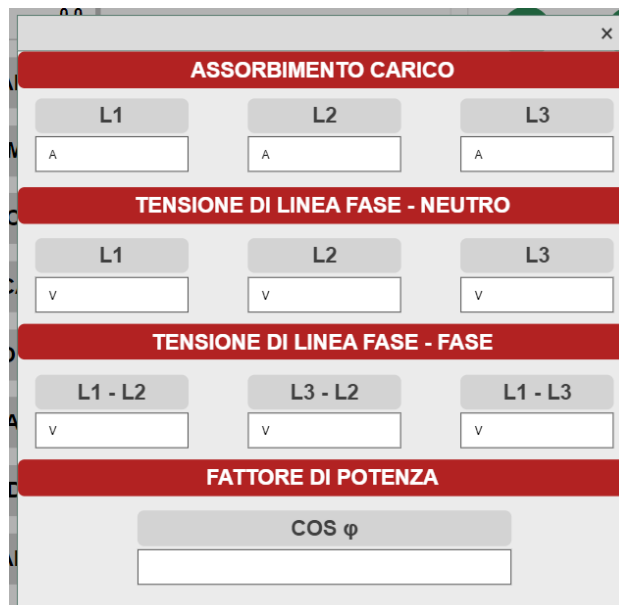

Figure 6.21: Automatic test results

In Figure 6.21 is shown the dialog that is opened when clicking on VISUALIZZA RISULTATI in which are displayed all the values measured by the M4M after the test that consist in 1 complete cycle in PROVA A CARICO (load test). Line labels will be colored in green if the values are near the ones used for the test, in red otherwise. Test can be done multiple times. Each time a test is done again, there will be used the new values measured by the M4M in the last test.

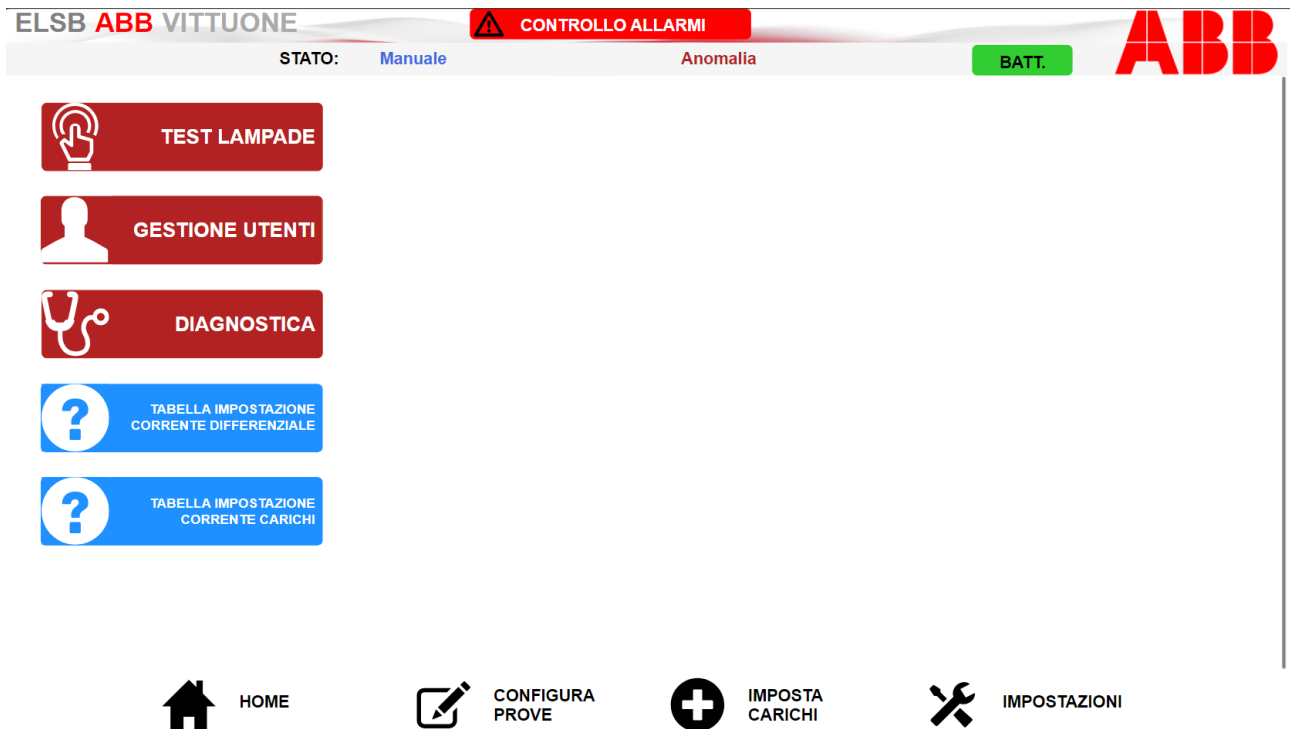

Figure 6.22: Settings Page

The setting page contains the button to enable the test of the lamps, there are located one per each working station and highlight the presence of power. This test consists in turning ON the three lamps to see if they work. The second button opens the User Management page (see Figure 6.23). Third button open the B&R System Diagnostic Manager that is a web page to check the status of both hardware and software and CPU status. Buttons in blue open pages related to table to guide the operator in setting the differential current by regulating the rheostats and setting the loads circuit current when choosing the manual selection.

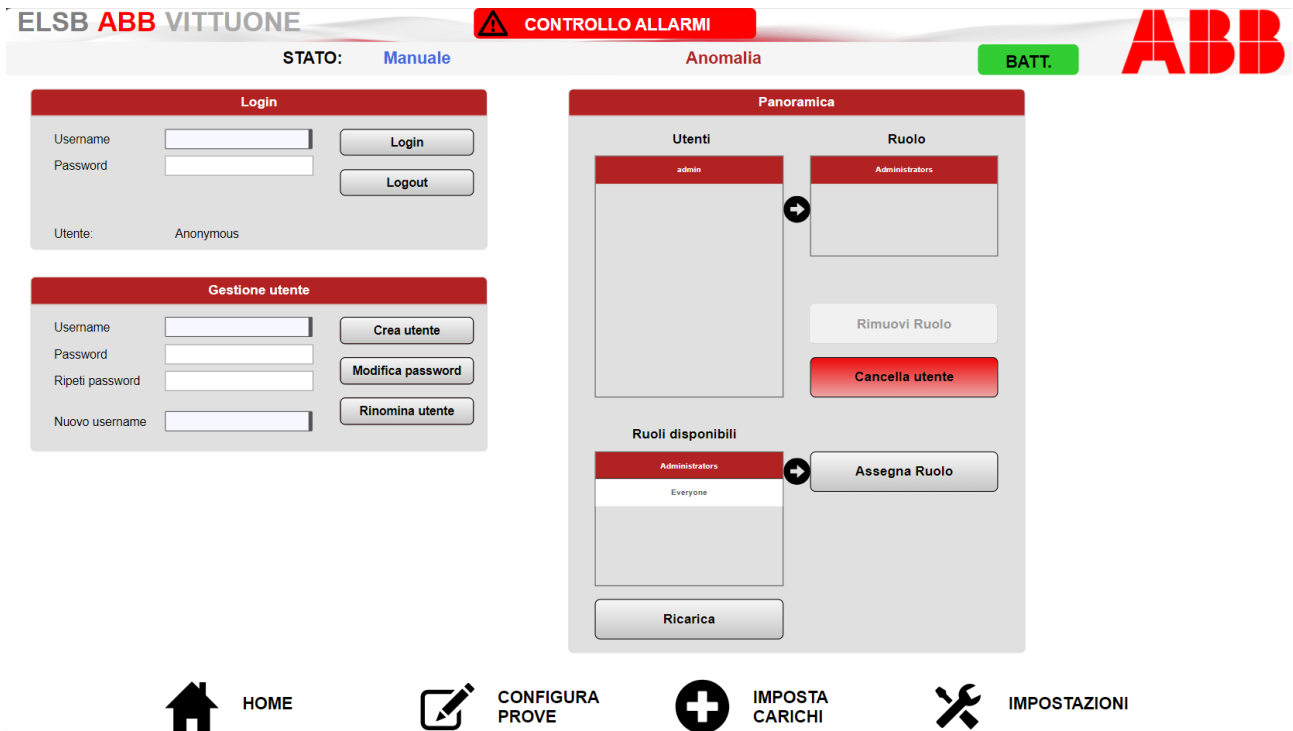

Figure 6.23: User Management Page

The last page is the User Management Page from which is possible to create users, to assign a role to each user or creating new roles. The permission of creating or cancelling users or roles is for administrator only.

The control logic for what concerns the loads has been developed in such a way that the selection of the resistances and inductances to switch ON or OFF is done automatically through a logic based on combinatorial calculus.

Is important to notice that the code has been modified in its whole structure with the implementation of new functions and function blocks. This also because lot of new functionalities have been implemented with respect to the old machine. Furthermore, the code from which the whole thesis work is started was not the final one that was present on the machine because the original code was not available. For this reason, all the modifications to have the perfect functioning of the machine have been done during the debugging phase.

CHAPTER 7

TESTING PHASE

The testing phase for this project has been divided into two main steps: the first simulation of the whole project on the Automation Studio simulation environment and the second one on the real machine.

During the second phase has been done the debugging of the whole new software keeping in connection the PC (with Automation Studio) with the CPU via Ethernet connection. In this way it has been possible to see the status of the variables in every moment and to force some of them if needed.

The test phase is started testing the manual manoeuvres to test the two-hand safety operation and the manual movement of the cylinders and the manual closing of the power.

Then the test 'PROVA A VUOTO' has been done in which has been discovered that the starting code was different from the one that was present before on the machine, the source code. This because there was a different logic to manage the power. For this reason, the logic for this type of test has been modified and adapted to test procedure given by the norm. In this test has been tested the automatic cycle but without current flowing through the piece under test.

The third part of the testing phase has been done on the loads circuit, switching them manually but through the HMI, checking the status of the contacts, the activation of the valve and through the test 'PROVA A CARICO' also the current and voltage flows have been checked.

After this test, the selection of the resistances and inductances to switch has been done automatically, without the user intervention. Furthermore, only in the configuration phase, the M4M values of voltage, current and power factor given as feedback to the control logic of the loads circuit allow to reach the desired current value. Currents and voltages value has been checked used a tester and a current clamp.

The last part of the test phase has been the 'PROVA i DIFFERENZIALE' during which has been done the setting of the differential current, testing all the connections of the rheostats circuit and the Keithley measurements. Also, in this case has been tested the automatic cycle.

During the whole test phase, the HMI has been tested and step by step has been done all the modifications to keep it more understandable. In fact, the first project of the new HMI was a bit different from the actual one, because it was very similar to the original one, but it was not so smart because of the presence of too many pages. The actual HMI is running on Google Chrome as a full screen application that is automatically

open every time the PC is switched ON. During the tests it has been discovered that sometimes the web page is automatically refreshed. This is caused by the version of Google Chrome that is installed on the Windows partition of the Industrial PC that is not perfectly stable with this type of HMI, but this is not a critical problem when using the HMI and will be fixed soon.

The last step of the testing phase will be done by some operators that did not follow this revamping project and that will use this machine given the user manual. This will be a critical part of the testing phase because will allow to understand if the HMI is efficient and smart to use, but it allow to collect lot of feedbacks that will be useful in modifying some parts of the HMI project or of the machine logic to make it very easy to use by the operator side and very efficient for the certification purposes of tested products.

CHAPTER 8

FUTURE IMPROVEMENTS

In addition to all the modifications described in the previous chapters, some other improvements are in progress and some other are planned.

Nowadays is in progress the development of reports after the test using all the data inserted during the configuration phase and all the measurements of the M4M and Keithley.

Is also in progress the modification of the motion part that now is with electro-mechanical pistons, with electro-valves. They will be replaced with servo motors, in particular, one motor position only with the possibility to slide between the three test stations. With this modification will be also possible to keep measures about the force used to switch ON and OFF the product under test during the whole test. This will give the opportunity to also study the way in which the force changes after lot of cycles.

Another improvement in project is the automation of the differential current selection that is now managed by 3 different rheostats. The idea is to realize the circuit with electronic switches with series and parallel resistances and with a motorized rheostat to do a more precisely regulation of the resistance.

The last improvement will be the control in remote of different command of the machine and for this purpose an ABB Free@Home has been already installed on the rear part of the machine, but to do this with all the commands will be probably necessary to also install a camera on the machine.

Furthermore, the machine will be again certified and for this purpose also installed on the machine a SAFERY PLC to manage the emergency button operation and the protection to detect the opening and closing operation of the doors in such a way that this control part is not correlated with the whole control part of the machine.

All these future improvements have the purpose of obtaining more results from tests to understand the behaviour of both electrical and mechanical parts of the products under test after lot of fatigue cycles.

CHAPTER 9

CONCLUSIONS

This thesis work has been a very interesting and challenging experience because it has covered lot of different areas about the development of a project in a real and very big company covering both the hardware and software development and the contact with sellers of big companies like B&R Automation.

Furthermore, it has been possible to do lot of training to learn how to use the Automation Studio software and lot of self-training about industrial automation programming environment.

The aim of this project was to develop a revamping on a machine already present and in function in the laboratory of ABB ELSB in Vittuone (MI).

As a result of this thesis work it has been possible to implement a more sophisticated and useful machine that is still able to do all the basic previous functions and more advanced using automation ones like in the selection of resistances and inductances to switch ON or OFF in the loads circuit.

The choice of using a Panel PC with an integrated CPU and double partition (Windows and B&R Hypervisor) instead of a common PLC and the choice of using Automation Studio to develop the whole software part allowed to add lot of functionalities. Another interesting additional aspect has been done by adding new measurement instruments that allow to collect more data from the test. This is a crucial aspect in the R&D field because allow to understand more in case of failure of a product under test.

Furthermore, the other important improvement has been done with the realization of a new, smart, and more intuitive HMI that allow the operator to spend less time to set up the machine.

Unfortunately, the stage period was not sufficient to completely develop the part regarding the automatic report generation and the remote control of the machine due to the long delivery times to have all the hardware components, PLC installation and the modification of the circuit related to the load management.

At the end of this thesis project, all the starting requirements has been completed and lot of new upgrades, like also in the motion field, will be done in the next months.

10 BIBLIOGRAFY

[1] Internal UAPFOR User Manual

[2] Internal drawing documents about UAPFOR and load circuits

[3] www.br-automation.com

[4] new.abb.com

ANNEX A

Old PLC I/Os Drawings

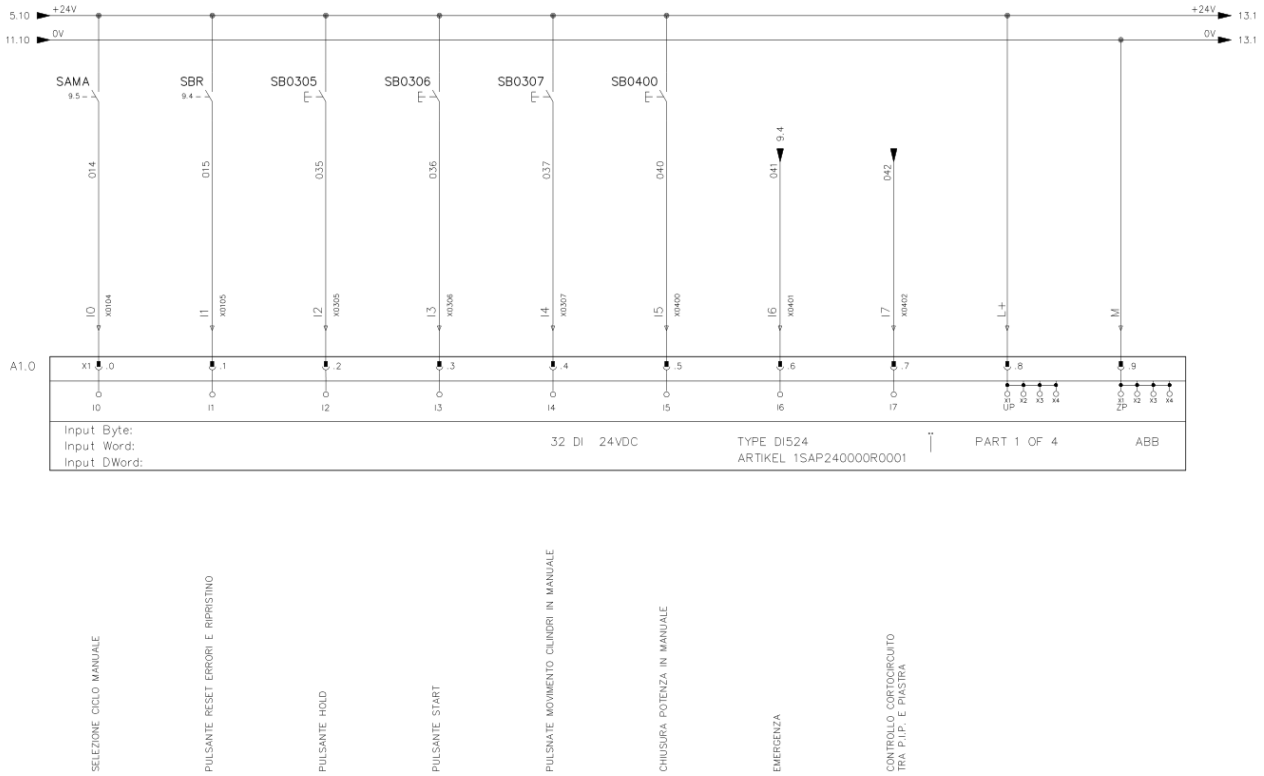

Figure A.1: Original PLC digital inputs

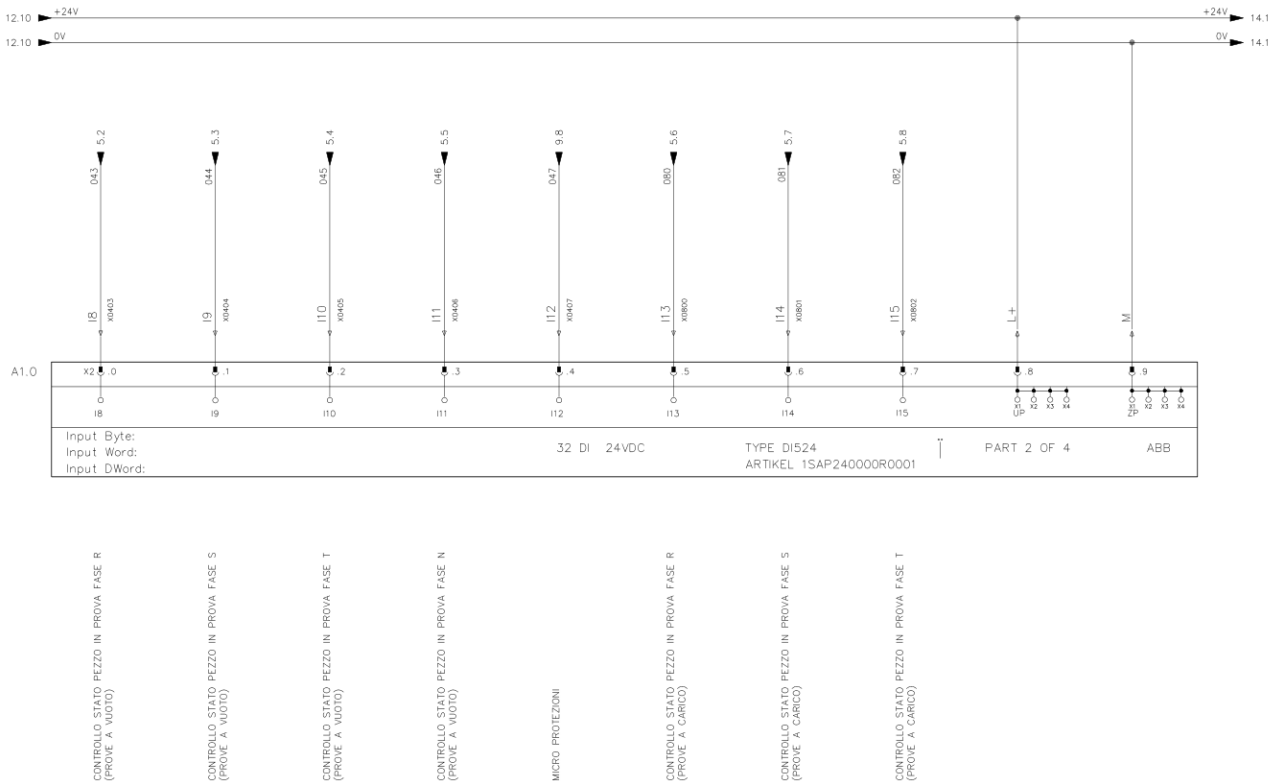

Figure A.2: Original PLC digital inputs

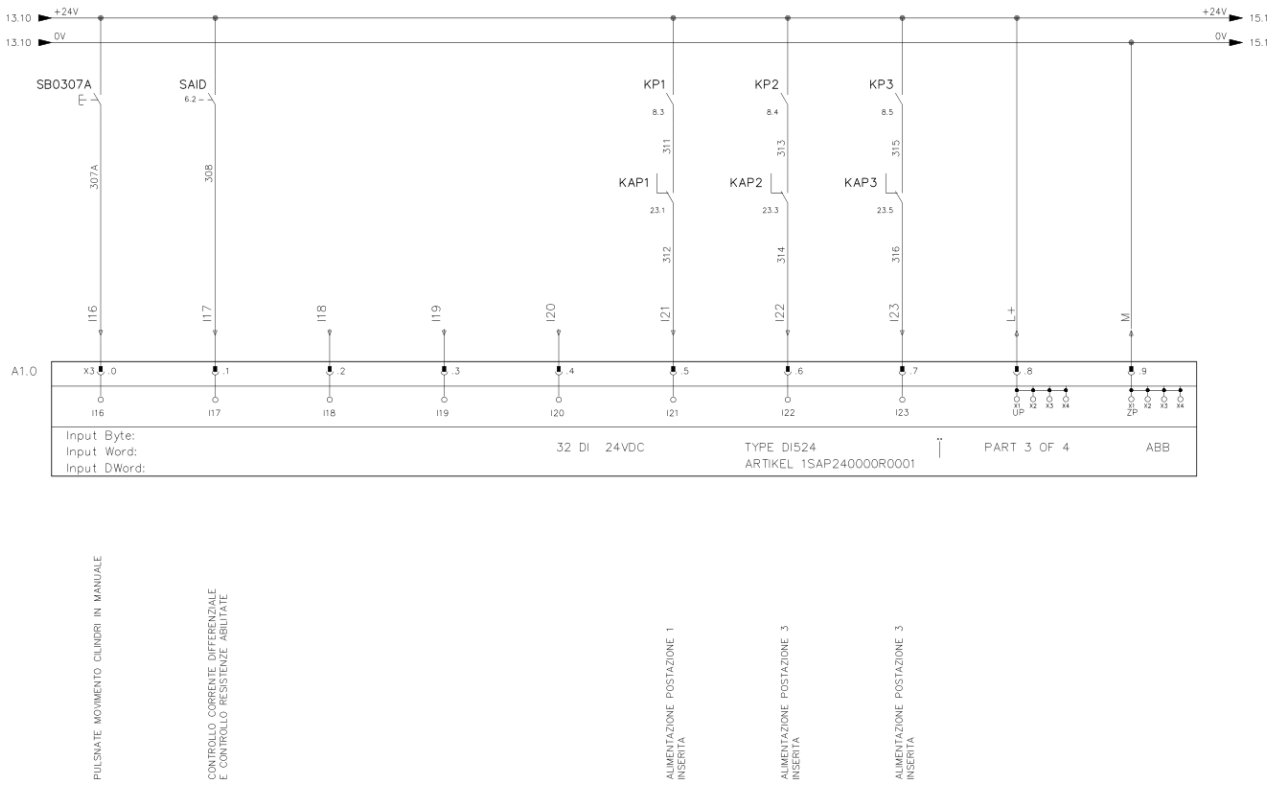

Figure A.3: Original PLC digital inputs

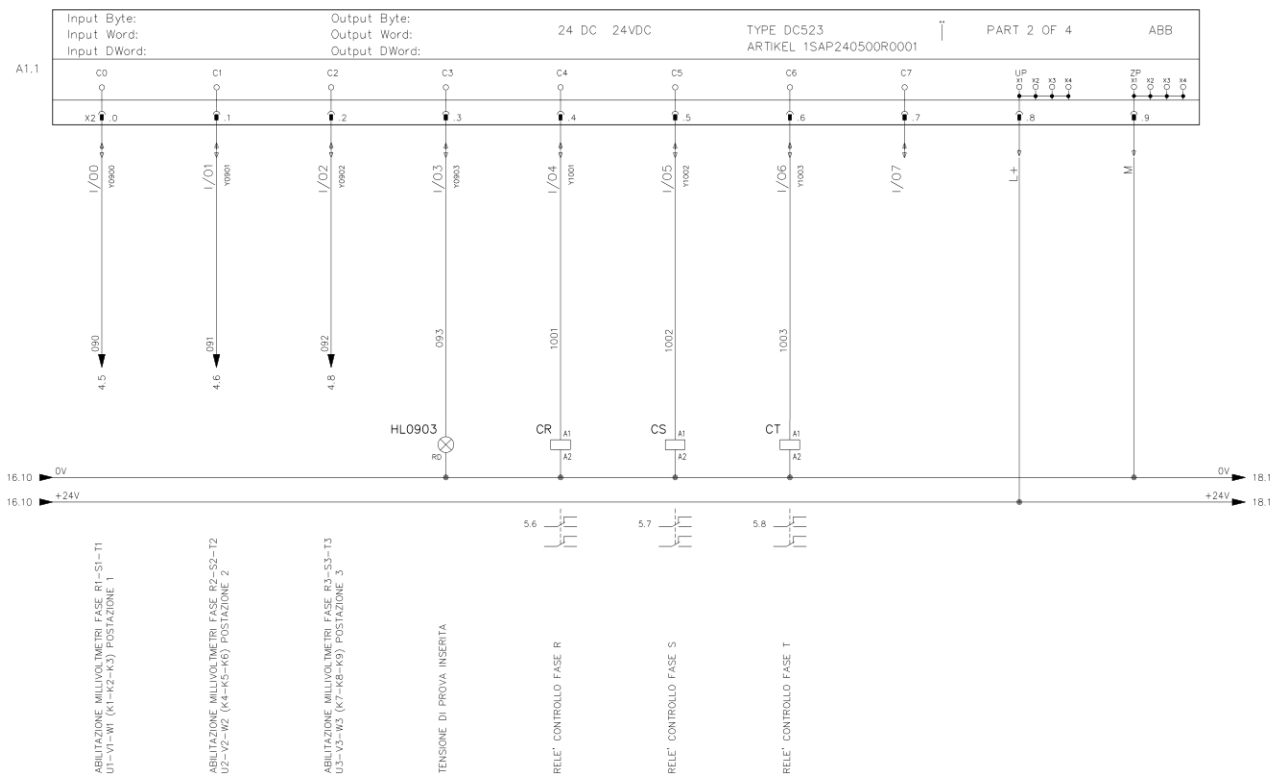

Figure A.4: Original PLC digital outputs

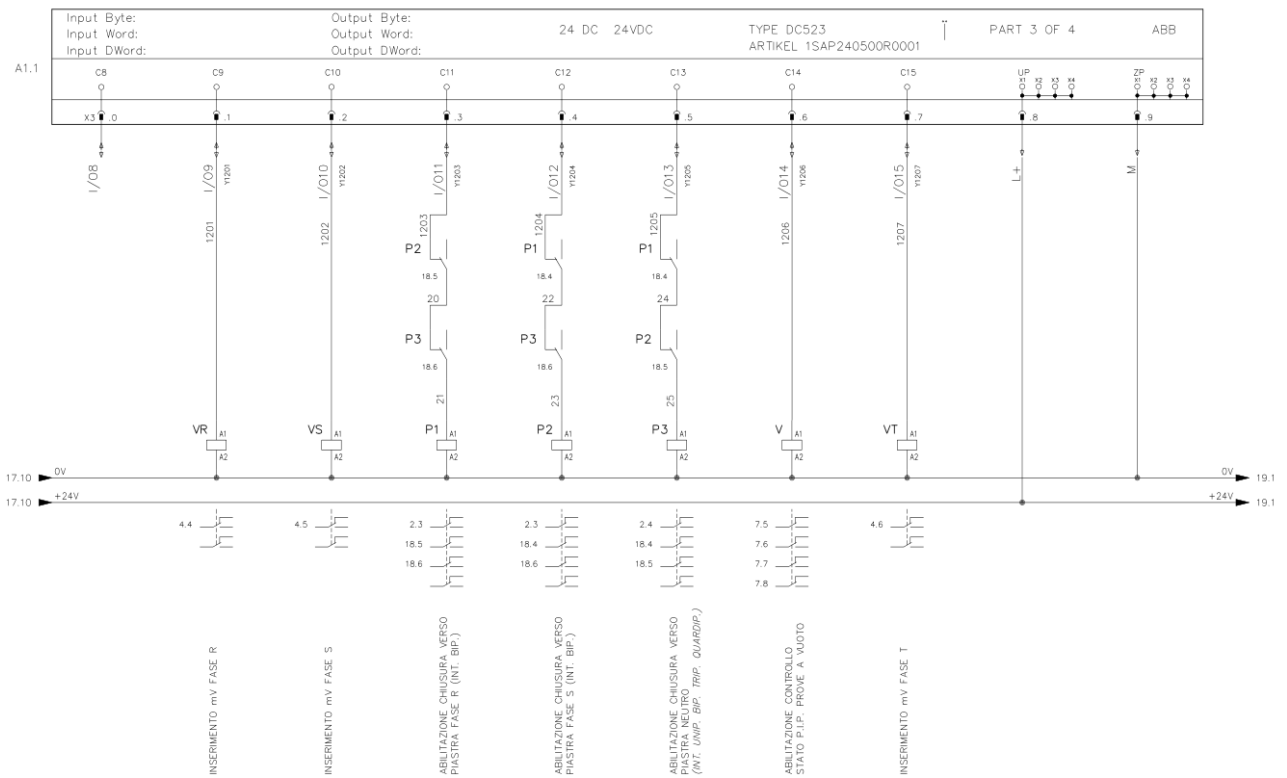

Figure A.5: Original PLC digital outputs

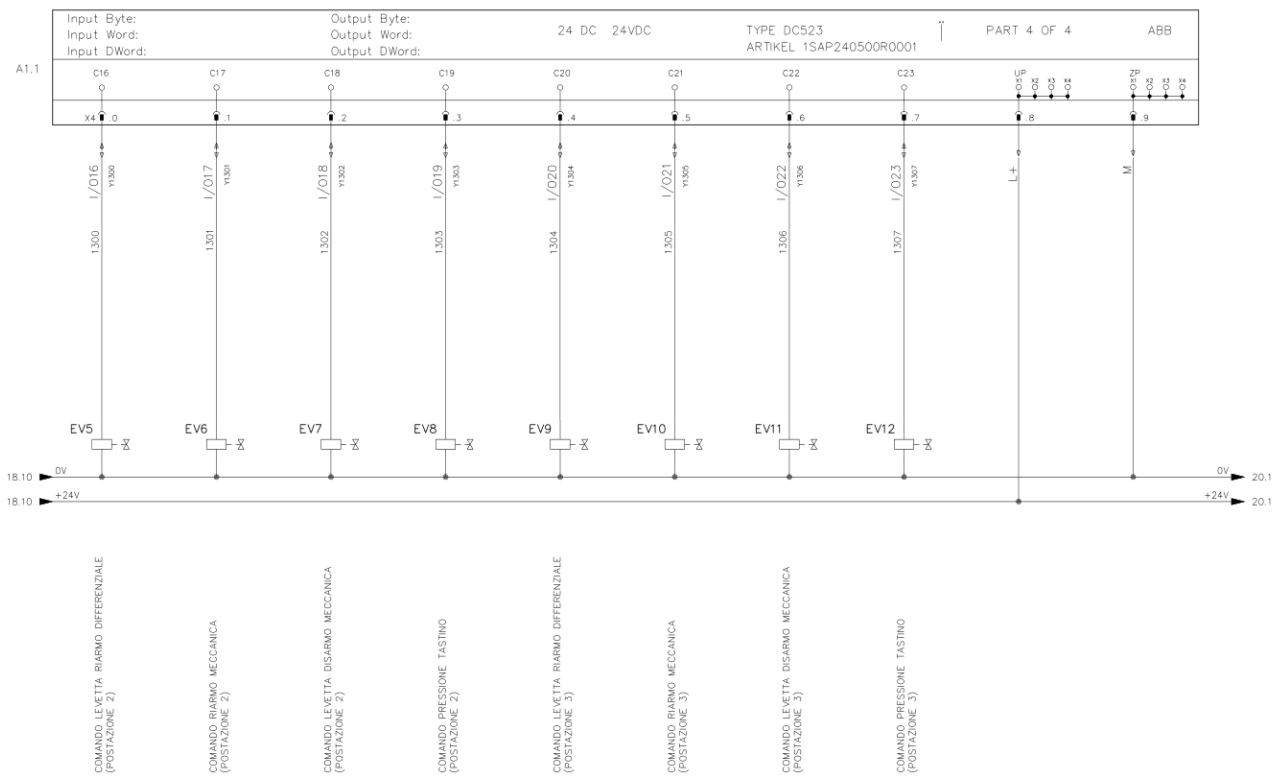

Figure A.6: Original PLC digital outputs

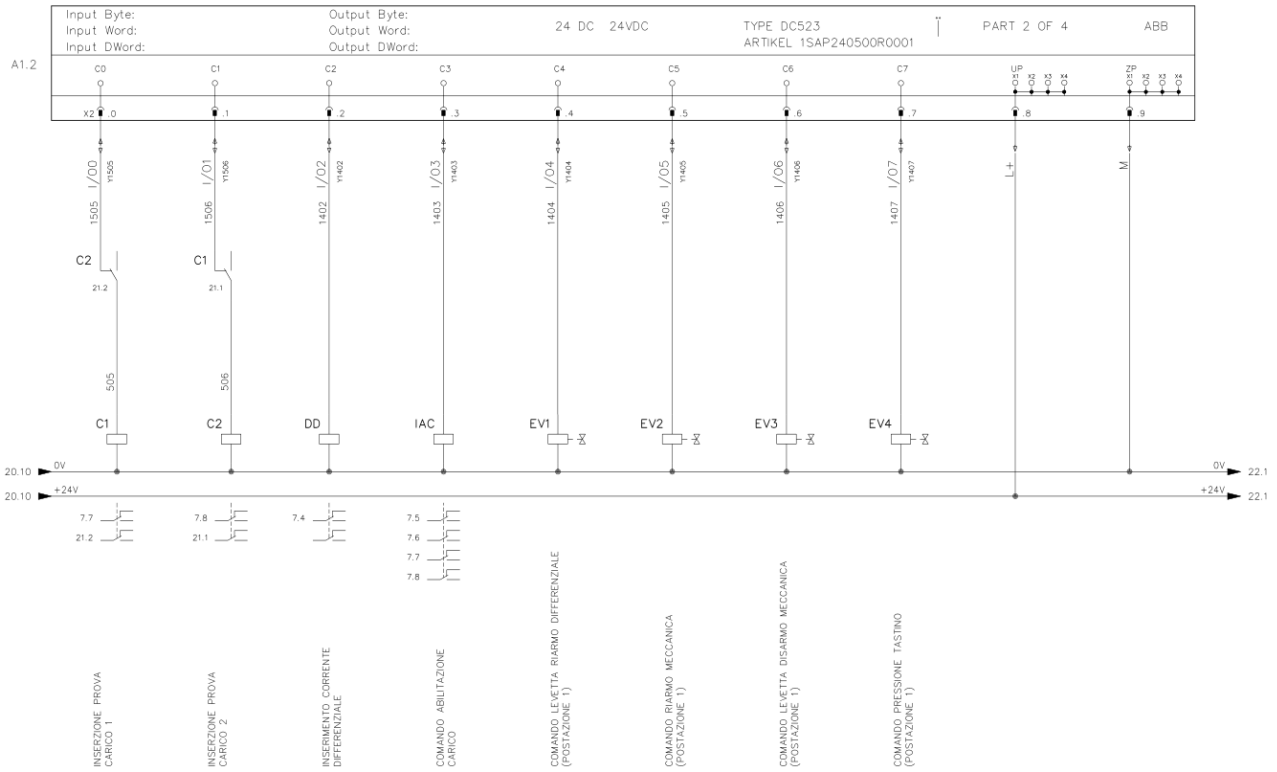

Figure A.7: Original PLC digital inputs/outputs

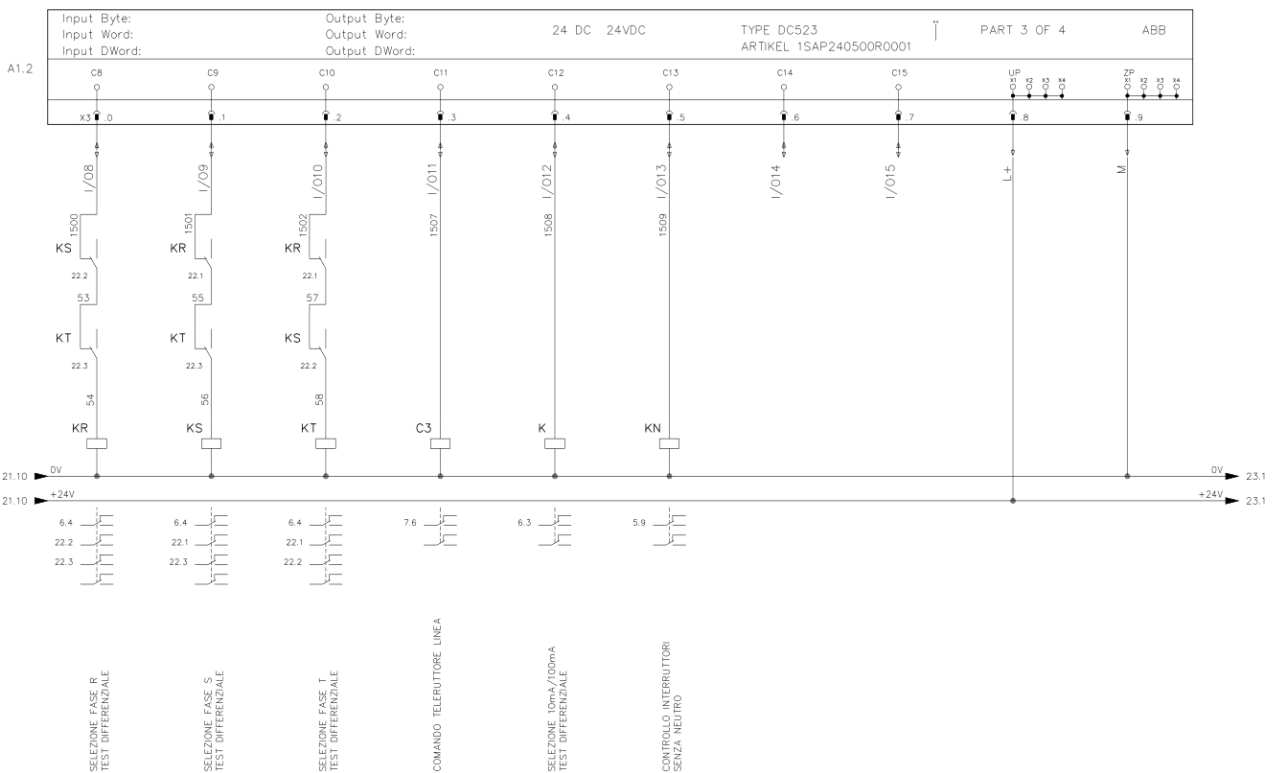

Figure A.8: Original PLC digital inputs/outputs

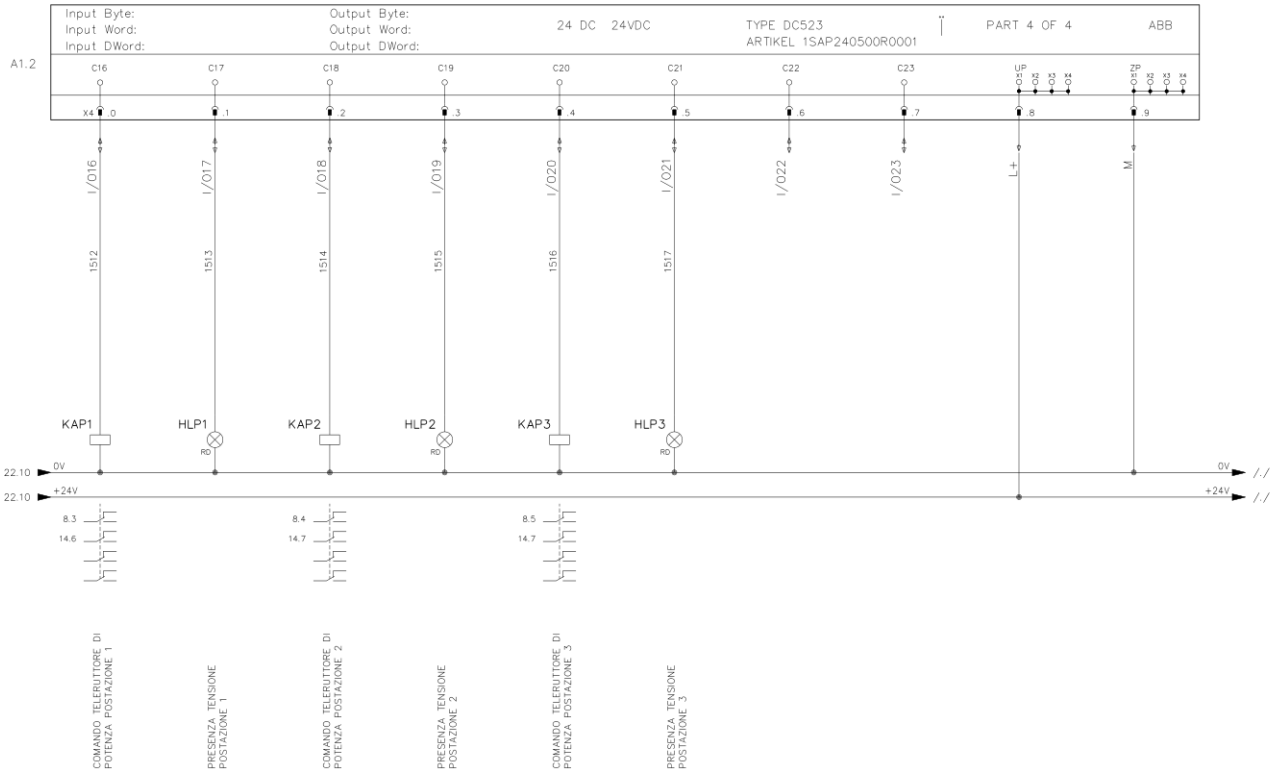

Figure A.9: Original PLC digital inputs/outputs

ANNEX B

New PLC I/Os Drawings

LEGENDA:
 IX0.0 : SELEZIONE CICLO MANUALE
 IX0.1 : PULSANTE RESET ERRORI E RIPRISTINO
 IX0.2 : PULSANTE HOLD
 IX0.3 : PULSANTE START
 IX0.4 : PULSANTE MOVIMENTO CILINDRI IN MANUALE
 IX0.5 : CHIUSURA POTENZA IN MANUALE
 IX0.6 : EMERGENZA
 IX0.7 : CONTROLLO CORTOCIRCUITO TRA P.I.P. E PIASTRA

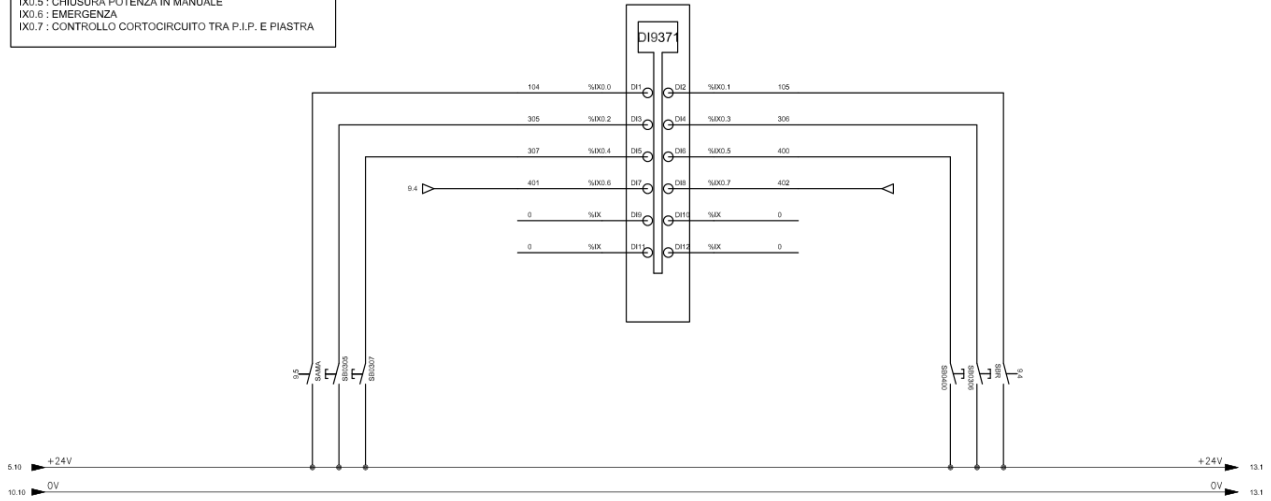

Figure B.1: New PLC digital inputs

LEGENDA:
 IX1.0 : CONTROLLO STATO PEZZO IN PROVA FASE R (P. VUOTO)
 IX1.1 : CONTROLLO STATO PEZZO IN PROVA FASE S (P. VUOTO)
 IX1.2 : CONTROLLO STATO PEZZO IN PROVA FASE T (P. VUOTO)
 IX1.3 : CONTROLLO STATO PEZZO IN PROVA FASE N (P. VUOTO)
 IX1.4 : MICRO PROTEZIONI
 IX1.5 : CONTROLLO STATO PEZZO IN PROVA FASE R (P. CARICO)
 IX1.6 : CONTROLLO STATO PEZZO IN PROVA FASE S (P. CARICO)
 IX1.7 : CONTROLLO STATO PEZZO IN PROVA FASE T (P. CARICO)

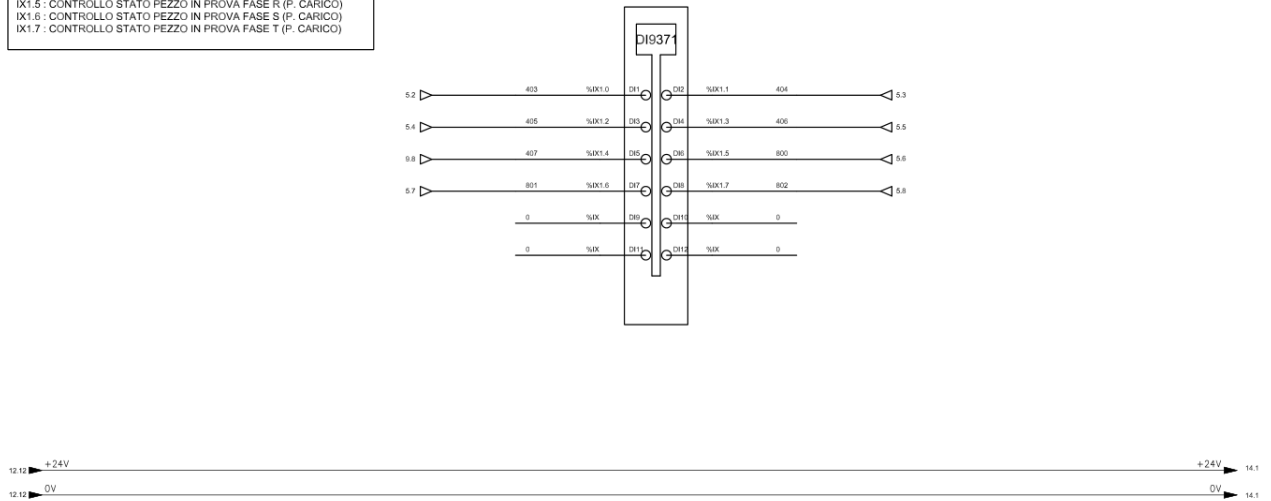

Figure B.2: New PLC digital inputs

LEGENDA:
 IX2.0 : PULSANTE MOVIMENTO CILINDRI IN MANUALE
 IX2.1 : CONTROLLO CORRENTE DIFF. E CONTROLLO RES. ABILITATE
 IX2.5 : ALIMENTAZIONE POSTAZIONE 1 INSERITA
 IX2.6 : ALIMENTAZIONE POSTAZIONE 2 INSERITA
 IX2.7 : ALIMENTAZIONE POSTAZIONE 3 INSERITA

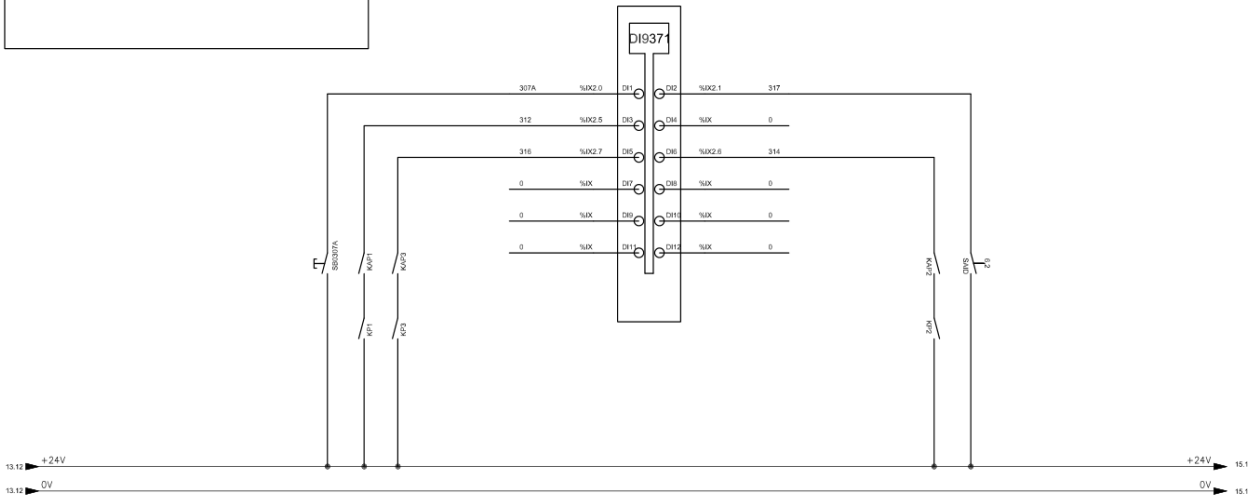

Figure B.3: New PLC digital inputs

LEGENDA:
 QX20.0 : ABIL. mV FASE R1-S1-T1 POSTAZIONE 1
 QX20.1 : ABIL. mV FASE R2-S2-T2 POSTAZIONE 2
 QX20.2 : ABIL. mV FASE R3-S3-T3 POSTAZIONE 3
 QX20.3 : TENSIONE PROVA INSERITA
 QX20.4 : RELE' CONTROLLO FASE R
 QX20.5 : RELE' CONTROLLO FASE S
 QX20.6 : RELE' CONTROLLO FASE T
 QX21.1 : INSERIMENTO mV FASE R
 QX21.2 : INSERIMENTO mV FASE S
 QX21.7 : INSERIMENTO mV FASE T

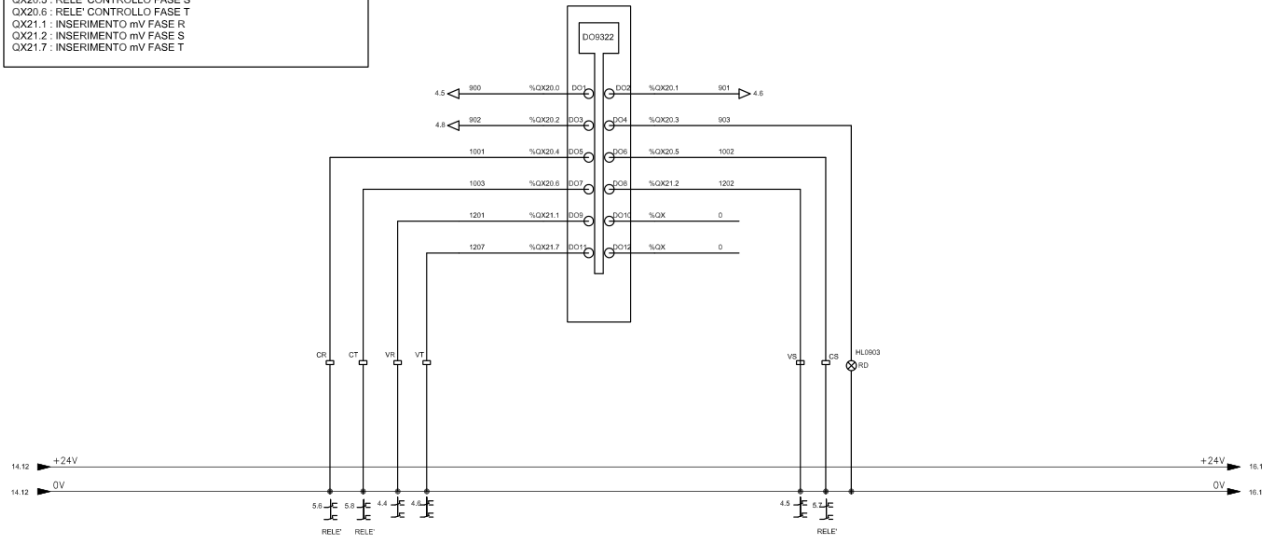

Figure B.4: New PLC digital outputs

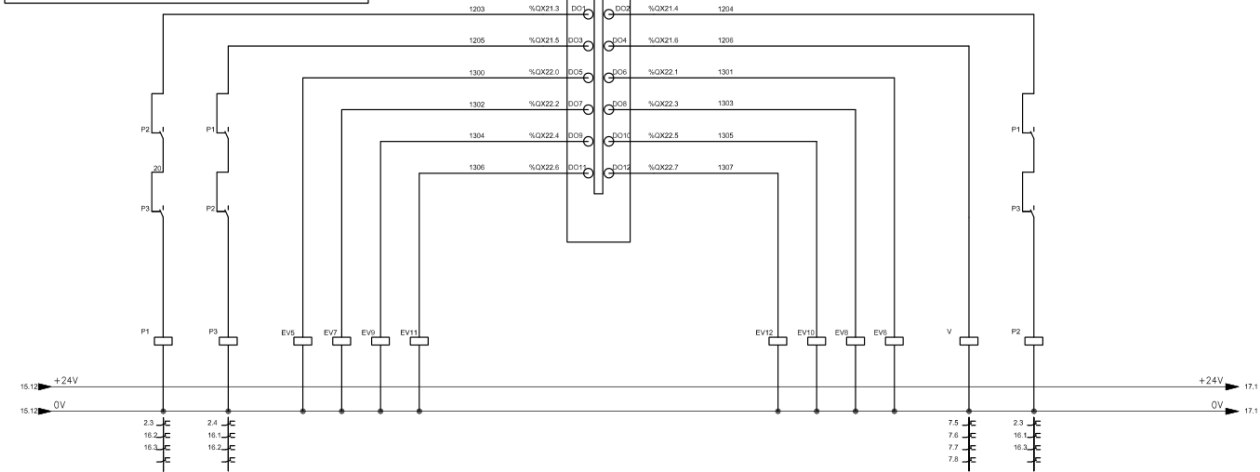
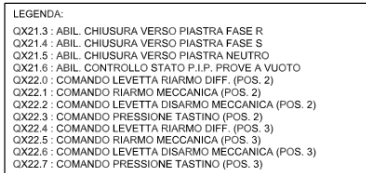

Figure B.5: New PLC digital outputs

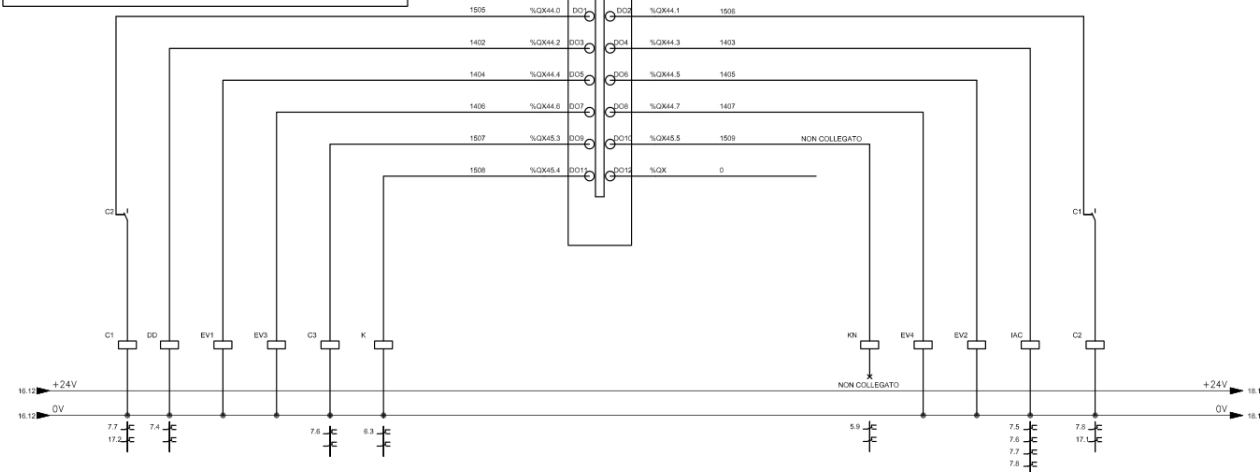
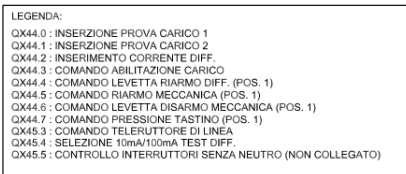

Figure B.6: New PLC digital inputs/outputs

LEGENDA:
 QX45.0 : SELEZIONE FASE R TEST DIFFERENZIALE
 QX45.1 : SELEZIONE FASE S TEST DIFFERENZIALE
 QX45.2 : SELEZIONE FASE T TEST DIFFERENZIALE
 QX46.0 : COMANDO TELERUTTORE DI POTENZA POS. 1
 QX46.1 : PRESENZA TENSIONE POS. 1
 QX46.2 : COMANDO TELERUTTORE DI POTENZA POS. 2
 QX46.3 : PRESENZA TENSIONE POS. 2
 QX46.4 : COMANDO TELERUTTORE DI POTENZA POS. 3
 QX46.5 : PRESENZA TENSIONE POS. 3

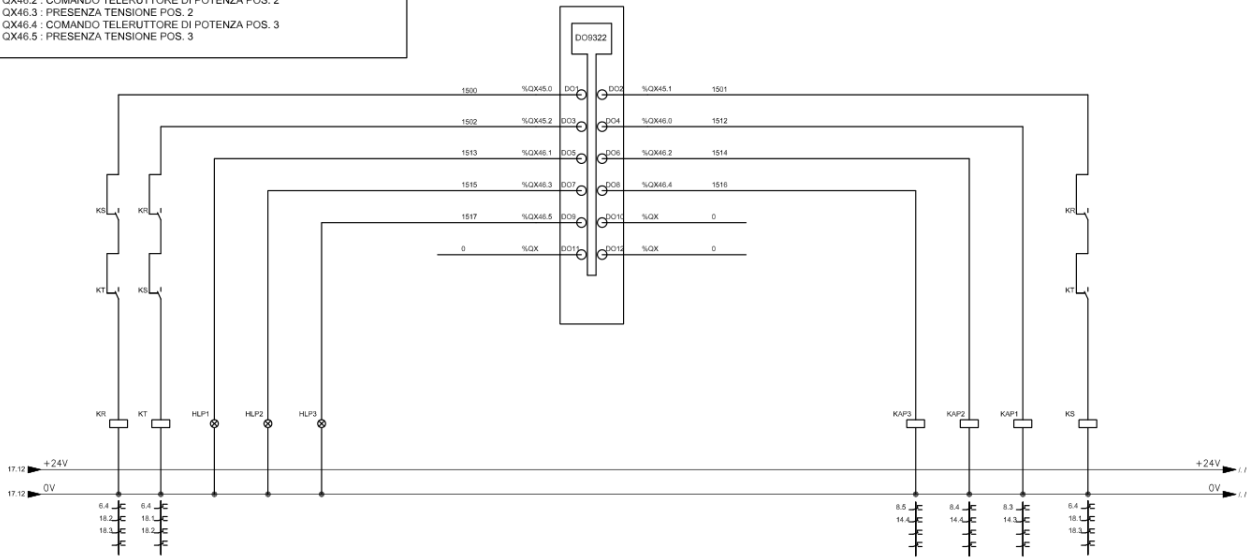
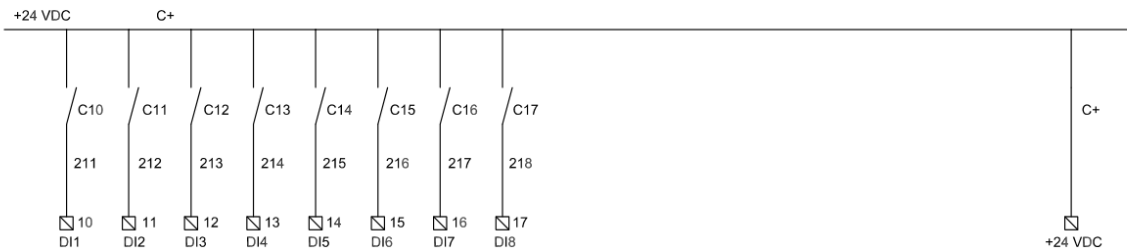

Figure B.7: New PLC digital inputs/outputs

ANNEX C

New I/Os Drawings for loads circuit

INDUTTANZE - REATTANZE



CARICHI - RESISTENZE

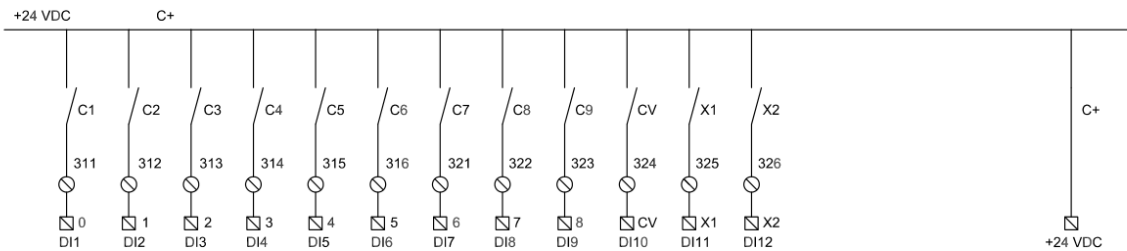

Figure C.1: Loads PLC digital inputs

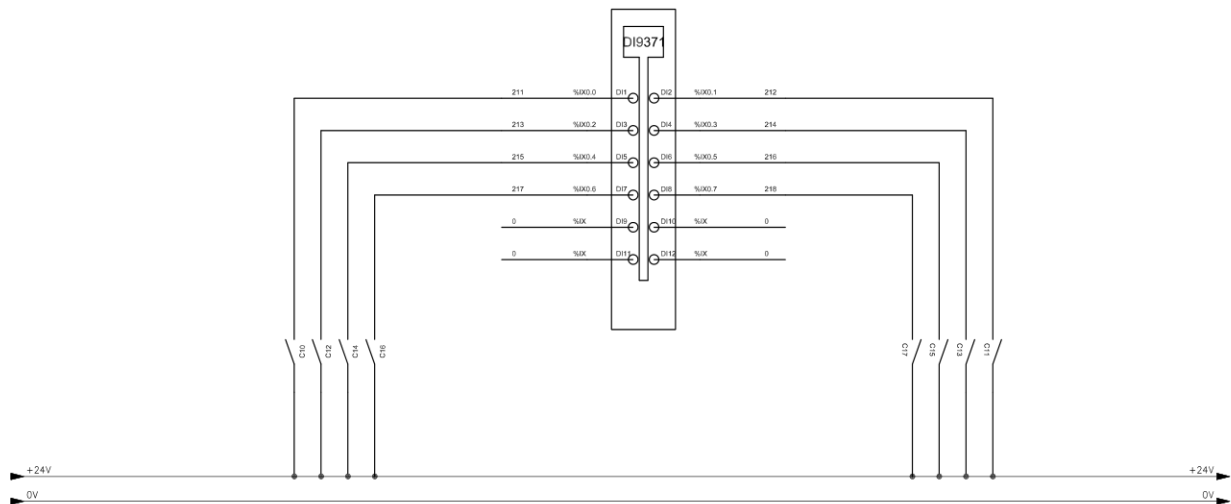

Figure C.2: Loads PLC digital inputs

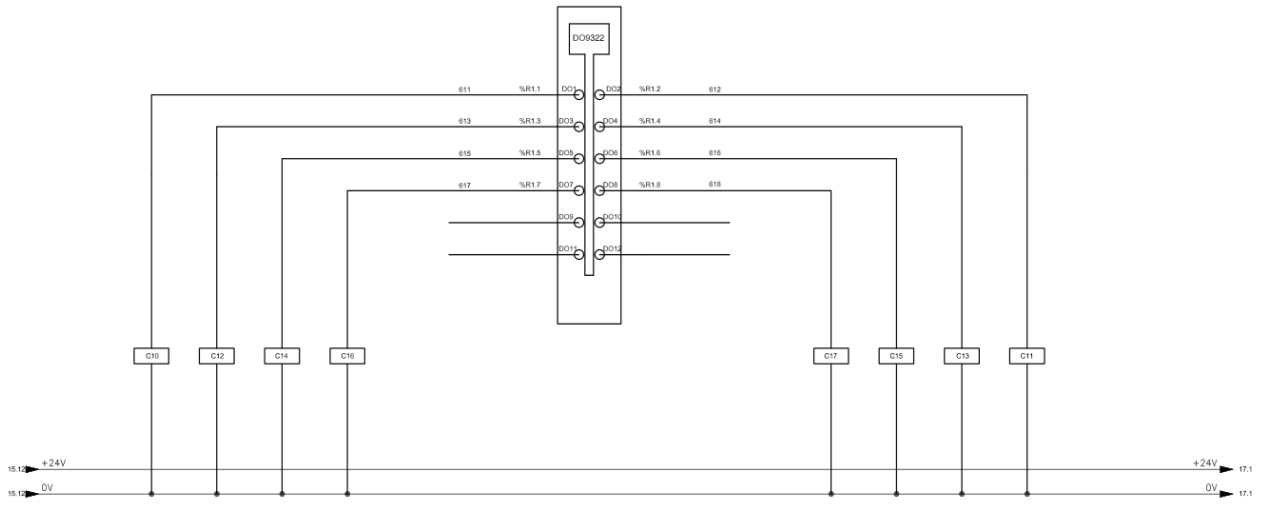

Figure C.5: Loads PLC digital outputs

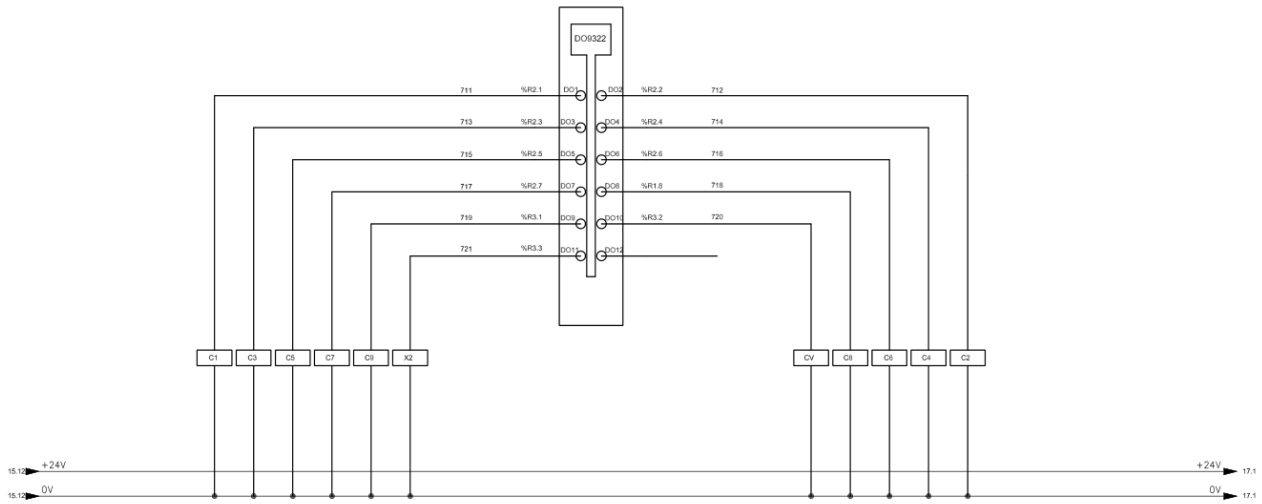

Figure C.6: Loads PLC digital outputs

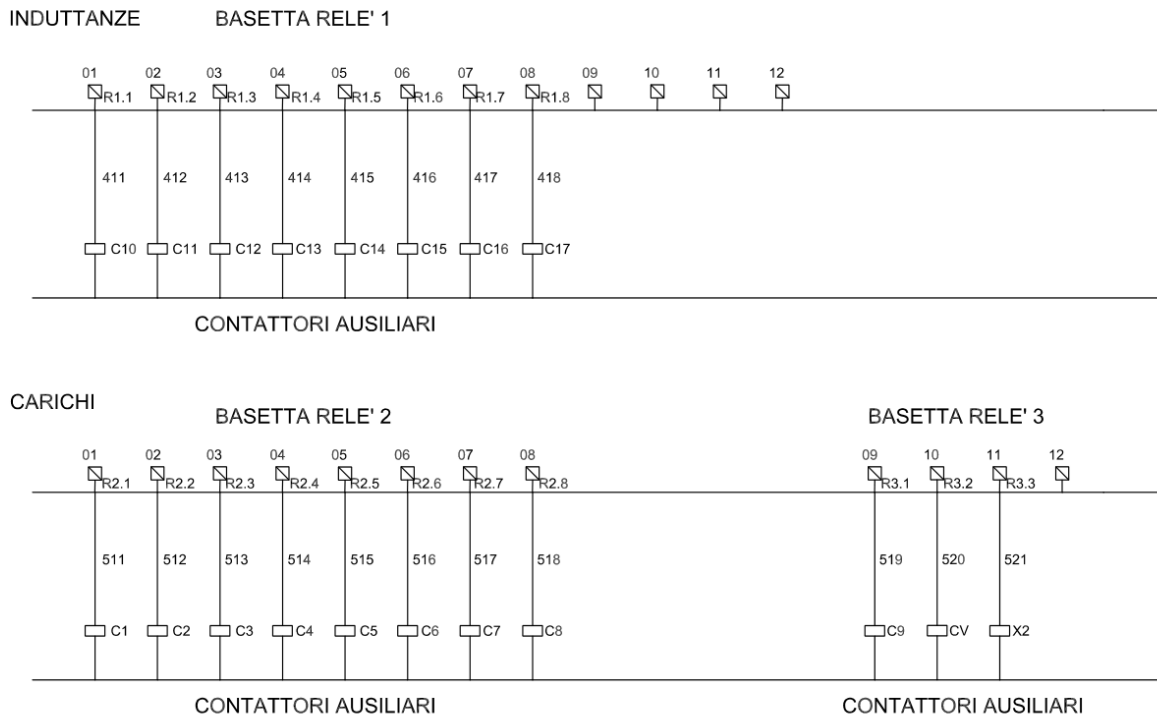

Figure C.7: Loads circuit relay bases

