



**Politecnico  
di Torino**

**Master's Degree in Building Engineering**

Master's Degree Thesis

**Exploring the potential of design for manufacture and assembly  
(DFMA) in post disaster housing solutions.**

**Supervisor**

Prof. Valentina Villa

*Signature*

.....

**Candidate**

Aashir Ashfaq

*Signature*

.....

# Index

Index of Figures .....	3
Index of Tables .....	4
Abstract.....	5
Introduction.....	6
Overview of DFMA:.....	6
Stages of DFMA .....	6
DFMA Concept in Construction.....	8
Natural Disasters .....	9
Post Disaster Housing Strategies .....	9
Emergency Shelters .....	10
Temporary Shelters.....	10
Temporary Housing .....	10
Progressive Shelter.....	11
Core Shelter .....	11
Permanent Housing.....	11
State of the Art.....	13
Historical Review of the Post disaster Housing Solutions.....	13
Real life Approaches and Designs for Temporary Housing Solutions .....	14
New Approaches to Sustainable Housing Solutions.....	30
G.P Shipping Containers.....	30
3-D Printing .....	34
Essential Homes Research Project.....	36
DFMA Incorporation: Further Improvement.....	39
DFMA Application to Temporary Shelters in Philippines .....	39
Adequate Shelter Guidelines.....	41
“Kit of Parts” Modular Design .....	44
Proposed Temporary Home for Hawaii Disaster (Case 1) .....	44
UBUILD Construction System (Case 2).....	48
Proposed Solution .....	53
Conclusion .....	68
References.....	69

# Index of Figures

Figure 1: Stages of DFMA.....	7
Figure 2: Overlaps between different shelter terminologies.....	12
Figure 3:Map of Haiti Earthquake .....	15
Figure 4:Emergency Shelters Provision After Disaster .....	15
Figure 5: Temporary Shelter Solution By HHi.....	16
Figure 6: Map of Earthquake, Turkey.....	16
Figure 7: Fevzi Cakmak temporary housing site .....	17
Figure 8: GumusPinar Temporary Housing Site .....	17
Figure 9: Map of Earthquake, Iran.....	18
Figure 10: Post Disaster Destruction, Philipines .....	19
Figure 11: Map of Typhoon Yolanda .....	20
Figure 12: Bunk Houses.....	21
Figure 13: Paper Temporary Shelter.....	21
Figure 14: Map of Hurricane Katrina .....	25
Figure 15: Temporary Trailers.....	25
Figure 16: Katrina Cottages .....	26
Figure 17: Map of Sichuan (Wenchuan) Earthquake .....	27
Figure 18: Happy Homeland.....	28
Figure 19: Container Temporary Housing.....	31
Figure 20: Housing Plans.....	32
Figure 21: Exterior & Interior, Future Shack.....	33
Figure 22: Apri Cor House .....	35
Figure 23: Gaia – Earthhouse .....	36
Figure 24: Exterior, Essential Homes .....	37
Figure 25: Interior, Essential Homes .....	37
Figure 26: Section and Floor Plan of temporary shelter .....	40
Figure 27: Adequacy of Shelter .....	42
Figure 28: 3D- Scheme of the Base Module.....	45
Figure 29: Module Options.....	46
Figure 30: Flexible Configurations.....	47
Figure 31: Illustration of Solar Panels and RainWater Catchment.....	47
Figure 32: Plan of Ubuild Temporary Home.....	49
Figure 33: General Scheme of the Base Module .....	50
Figure 34: Construction Scheme of the Ubuild Temporary Home.....	51
Figure 35: Double Story Layout of Temporary Homes.....	52
Figure 36: Ground Screws .....	56
Figure 37: Ground Screws Foundation Illustration .....	56
Figure 38: Steel SIP & Snap and Lock Detail .....	61
Figure 39: Snap-N-Lock Installation Detail .....	62
Figure 40 : Prototype Floor Plan.....	64
Figure 41: Prototype Base Module & Extension Plan.....	64
Figure 42: Prototype 3D - Illustrations .....	65

## Index of Tables

Table 1: Disaster Summary - Developing Countries .....	22
Table 2: Shelter Summary - Developing Countries .....	24
Table 3: Disaster Summar - Developed Countries .....	29
Table 4: Shelter Summary - Developed Countries .....	30
Table 5: Living Space Guidelines.....	43
Table 6: Comparative Assessment.....	53
Table 7: Proposed Solution.....	54
Table 8 : Ground Screw Installation Steps .....	57
Table 9: Ground Screws Detail.....	58
Table 10; Analysis of Snap-N-Lock Panels to Traditional Timber Frames and OSB SIPs ....	60
Table 11: Steel SIPs Detail .....	63

# Abstract

Now more than ever, humankind is currently exposed to a wide range of dangers and catastrophic occurrences. Natural Disasters have grown due to climate change, causing suffering for people in addition to man-made catastrophes.

As a result, such catastrophes cause enormous losses on a material, social, and financial level.

People who are impacted by a disaster have a right to a dignified existence and, consequently, a right to help. All feasible measures should be taken to lessen the human suffering that results from a disaster or a conflict.

Measures have been taken primarily by various national and international organizations, mostly military and civil, to overcome the effects of catastrophe or conflict. The most popular approach currently being employed is giving victims refuge in ordinary tents, which do not meet the bare minimum of living conditions.

In most cases, what initially starts as a temporary shelter for a short period of time may end up being used for many years following the incident, years to even decades. Hence, it is vital to plan a housing solution that can be used for a longer period of time with the ability to be re-used in case of provision of permanent housing or to be incorporated into a permanent housing solution.

The research aims to respond to the housing solutions provided after catastrophic events by reviewing sustainable, low-cost, and time-efficient solutions through innovative construction techniques focusing on the potential of Design for Manufacture and Assembly (DFMA) in housing solutions for post-disaster situations.

## **Keywords**

DFM, DFA, DFMA, Post disaster Housing, Climate Change, Natural Disasters, Offsite Construction, Developed Countries, Developing Countries, Housing Solutions, 3d printing, General Purpose Shipping Containers, Modular Construction, Ground Screws, Structural insulated panels (SIPs).

# Introduction

## Overview of DFMA:

The DFMA method is widely known as a methodical procedure for evaluating and improving product design for both economic manufacturing and assembly. [1] There are two components of DFMA: design for manufacture (DFM) and design for assembly (DFA). DFM is principally concerned with making individual parts, and DFA addresses the means of assembling them. [2]

Design for manufacture/manufacturing (DFM) is a discipline in which products are designed to be as easy and inexpensive to produce as possible. It is closely related to design for assembly (DFA), but while DFM is primarily concerned with how individual parts are manufactured, DFA is concerned with how they are assembled. Since most parts are built into more complex products, the ability to assemble them effectively is equally critical.[2]

The research on DFA was pioneered by Boothroyd and Dewhurst in 1987, who conducted a series of studies considering the assembly constraints during the design stages. This aids in avoiding manufacturing and assembly problems in the later stages of product development [4]. The lowest assembly cost can be achieved by designing a product that can be economically assembled by the most appropriate assembly system. The implication of the DFA concept is to consider how aspects of the design can be designed in a manner that minimizes work on site and, in particular, avoids ‘construction.’ [2]

The key principle is to produce a design with fewer parts as well as designing the parts which remain easy to assemble [5]. The fewer the number of parts, the greater the probability that all of them will be placed correctly [6]. To achieve that, Boothroyd and Dewhurst’s (1987) handbook introduced various ratings for each part in the assembly process based on the part’s ease of handling and insertion.

The research on DFM dates to more than 200 years old, based on a Frenchman who devised the concept of interchangeable parts in the manufacture of muskets, which were previously individually handmade. [8] In the construction context, DFM is the process of designing in a manner that enables specialist subcontractors to manufacture significant elements of the design in a factory environment. Panelized systems such as waòò claddings have been designed in this manner for years, and now the emerging hybrid systems (i.e., pods) and modular buildings (i.e., fully factory-built houses) also pertain to the DFM concept. [1]

## Stages of DFMA

Figure 1 illustrates a stage-by-stage breakdown of the typical DFMA process. Boothroyd noted that DFA should always be the first consideration, leading to a simplification of the product structure. This is followed by the economic selection of materials and processes and early cost estimates. In this process, cost estimates for the original design and new (or improved) design will be compared in order to make trade-off decisions. [9]

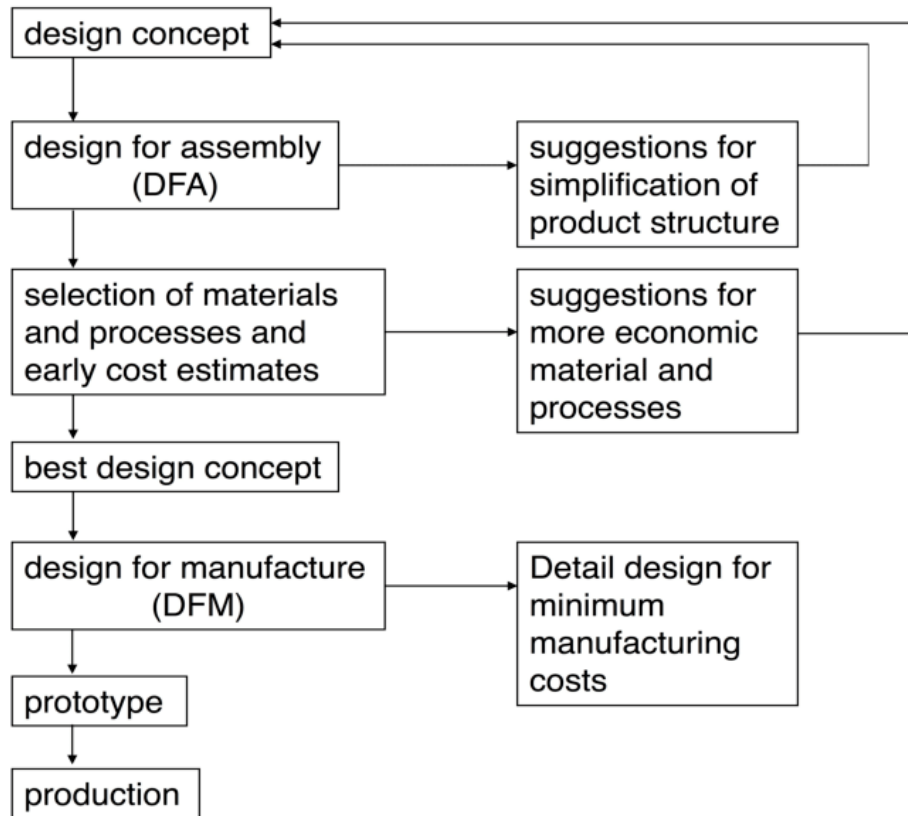

Figure 1: Stages of DFMA [83]

There are three methods of applying the DFMA process [2]. The first is to follow a set of general, non-specific, qualitative rules or guidelines and require someone (most likely designers and engineers) to interpret and apply them in each particular case. The aim is to encompass a diversity of products, processes, and materials.

Similarly, Stoll [5] outlined ten DFMA principles and rules:

1. minimizing the total number of parts,
2. developing a modular design,
3. using standard components,
4. designing parts to be multifunctional,
5. designing parts for multi-use,
6. designing parts for ease of fabrication,
7. avoiding separate fasteners,
8. minimizing assembly directions,
9. maximizing compliance and

## 10. minimizing handling.

The second method employs a quantitative evaluation of the design. The justification for this is that each component of the design can be given a numerical rating based on how assemblable it is [2]. The numbers can be summed for the entire design, and the resulting value is used as a guide to evaluate the overall design quality.

The third strategy—and most recent—is the automation of the entire procedure. It relies on computer software. An expert system can be created using these fundamental design principles after the design has been subjected to a quantitative analysis. The stem can be developed in such a way that a design can be analyzed, evaluated, and then optimized repeatedly by applying the rules to improve the design quality after each iteration. [3]

## **DFMA Concept in Construction**

Although the vogue of DFMA in construction is only a recent phenomenon, the potential benefits of DFMA to construction projects have been recognized for over two decades [1] [10]:

- interactive participation of all stakeholders in the design process;
- Design changes are implemented quickly;
- a better integration of the overall design;
- shortened the construction period without sacrificing construction quality;
- a minimum amount of manual labor;
- There is a significant reduction in on-site waste.

Given that the construction sector is significantly more heterogeneous than many other industries, some researchers questioned these potential advantages. Construction products (e.g., buildings and infrastructure) are usually customized by clients. It is thus extremely difficult for designers, like their counterparts in manufacturing, to ponder, optimize, prototype, and finally choose a design to build massively.

However, the construction industry has been reinventing itself and involving production theory (Koskela, 1992), especially through the integration of design, manufacture, and assembly.

A few empirical studies have been conducted to investigate the implementation of different DFMA principles in the design of specific building components. For example, Gerth et al. (2013) reported the application of DFMA to the light wall design for two four-story houses. Kim et al. (2016) showed the DFMA application for selecting the precast beam of a highway bridge. Chen and Lu (2018) reported a case study of a high-rise commercial building in which the curtain wall system was designed following a set of DFMA principles. Additionally, DFMA was described as being used to support the design of façades, restroom pods, and mechanical, electrical, and plumbing (MEP) components by Banks et al. (2018). [12]



## **Natural Disasters**

Crisis management after natural and non-natural disasters – defined as an unforeseen and sudden event that often causes great damage – is a global critical concern for governments and the population. Due to the current climate changes, the number of natural disasters has drastically increased in the last decades, having a considerable impact on the built environment: from fewer than 50 disasters reported in 1950 to more than 400 disasters in 2010 [13]. Besides human casualties, one of the most visible effects of any major disaster is the damage to houses and the high number of homeless people [14]. Therefore, housing provision plays a crucial role in the reconstruction programs since it is one of the most important needs for people and their well-being [15].

According to Forcael et al. [16], there were 373 natural disasters in 2014, the majority of which were weather-related. These disasters caused 296,000 life losses and about 110 million dollars in cost for about 208 million people directly or indirectly. Disasters damage not only homes and buildings but also almost all city infrastructure. For example, Hurricane Katrina in August 2005 damaged over 214,700 homes in New Orleans and forced over 800,000 citizens to live outside of their homes due to flooding [17].

According to the International Disaster Database [18], an ongoing trend exists regarding lower death tolls from previous years continuing into 2019. However, the frequency of disaster occurrence demonstrates an almost exponential growth, attributed to the worsening climate change and rapidly growing population and urbanization [19].

The immediate challenge for construction management following a catastrophic event is the quick reconstruction of destroyed homes and infrastructures. The most critical and time-consuming step of a post-disaster recovery and reconstruction process is promptly providing permanent housing for affected people [20]. It could take up to five years from the time of the disaster's impact for permanent housing needs to be met, according to data gathered by FEMA, which can be a very long time for the recovery of the average citizen and the return to a normal way of life [21]. It is a pivotal factor in the reconstruction process to minimize further devastating social and economic consequences in affected communities.

## **Post Disaster Housing Strategies**

Several experts in disaster relief and housing-related organizations have been using a three-category classification - emergency, temporary, and permanent - to describe various stages in the reconstruction of low-income housing after disasters in developing countries for a number of decades. The widespread use of these three categories, essentially a polarisation between provisional and permanent housing, was partly generated by changes in the construction sector in many countries with the introduction of sophisticated technological innovations and lifestyles produced in the developed countries that increased disparities in housing for different social groups; by an increase in urban migration that resulted in accelerated urbanisation[22] , land speculation and serious shortages of available housing; by the adoption in many countries of unrealistically ambitious standards for building codes for housing in general, as well as for government-supported housing programs that resulted both in costly shelter and low-income shelter that filtered upward to middle-income groups; and by the upsurge of a number of international, bilateral, and voluntary disaster relief agencies, one of whose functions was the provision of housing, and who generated their own philosophies of housing relief and

reconstruction[23]. The categories of emergency, temporary, and permanent housing, used not only for post-disaster shelter but also for shelter under standard conditions, are in many cases a device to legitimize a lack of government regulation of the housing sector, to provide visibility to the agencies' activities, and to disguise a lack of government programs to prevent the serious decay of the physical and environmental conditions of human settlements. Consistent with the general deterioration of the low-income housing sector in developing a rapid increment in the percentage of emergency and temporary housing has taken place in the last few years [24]

Although a vast range of alternative names has been given to these three-stage modes of housing in different countries,[25] in their simplest form, the distinctions between emergency, temporary, and permanent are based on the duration of the shelter and the expected length of occupancy by the users.

### **Emergency Shelters**

The term "emergency" is typically used to describe services that are offered in the wake of a catastrophic disaster, such as an earthquake, storm, or flood, in order to meet a sudden and urgent demand. The price of temporary housing varies between countries and depends on the type of shelter. For instance, the tents that were donated following the 1970 earthquake in Peru cost US \$87 each [26]. Designers, architects, engineers, and occasionally even relief organizations view the need for emergency housing as a chance to create innovative solutions that would be difficult to build using traditional building techniques. Instead of providing practical answers to the housing and societal issues caused by disasters, those designs are typically life-size models or utopian plans.

Examples of emergency housing solutions proposed, and in many cases executed, include pneumatic structures, single curvature shells using corrugated iron or asbestos, hexagon cardboard shelters, and geodesic and space frames following Buckminster Fuller's designs. In many cases, the adoption of those structures in concrete disaster cases, rather than helping the victims, helps the shelters' producers in the developed countries who use emergencies to free themselves from overstock of outmoded materials and shapes or as a testing ground for new products. For instance, the polyurethane domes developed by Bayer and sent by the West German Red Cross to Managua, Peru, and Turkey were inappropriate for the climates in those countries and culturally alien as a shelter form for the victims.

### **Temporary Shelters**

Temporary is applied to units that can be provided for a limited period until the disaster victims are able to obtain either the capital necessary to build a permanent house or the income to rent one. In theory, the difference between temporary and emergency housing is that the unit provided as temporary is expected to last for a longer period of time. [27].

### **Temporary Housing**

A rapid, post-disaster household shelter made from materials that can be upgraded or re-used in more permanent structures. This shelter can also be relocated from temporary sites to permanent locations. [28]

## **Progressive Shelter**

A post-disaster household shelter, planned and designed to be upgraded to a more permanent status. Achieved by integrating future transformation and alternative possibilities in the structural basis of the unit. Built on permanent sites to become part of permanent solutions. [28]

## **Core Shelter**

A post-disaster household shelter designed as a permanent dwelling to be a part of future permanent housing. This allows and facilitates the future process of extension by the household, following its means and resources. It is not a complete, full, permanent house, although it is built on a permanent site to become part of a permanent solution. [28]

## **Permanent Housing**

Permanent is applied to units expected to last for a substantial period, built according to certain standards, located in legally occupied land, with infrastructure and services (electricity, water supply, sewerage, drainage, roads, schooling, health care, and other public services). The cost varies because of country-to-country differences in the price of materials and labor, construction techniques, and size of the structures. However, the cost of permanent housing (in 1970 dollars) has been estimated at US\$4,000 and over [27].

In evaluating the classification of housing as emergency, temporary, and permanent, it is worth remembering that the temporal attribute that underlies the classification is arbitrary. In many cases, delays in the delivery and distribution of the units and a complex bureaucracy in charge of emergency housing affect the speedy provision of the units, which are, therefore, built and distributed a long time after the disaster.

For instance, the tents sent by the relief agencies to Peru after the May 31, 1970 earthquake arrived between five days and ten weeks after the disaster, and from their arrival to their distribution took some additional time, losing them, their character of truly "emergency" shelter. [11] In Lice, Turkey, 1,500 prefabricated (permanent) houses were completed by the Turkish government eight weeks after the earthquake and before the Oxfam emergency shelters were completed.[29]

Around the world, a sizeable population resides in temporary or emergency housing for an extended length of time (or permanently). The temporary or permanent nature of housing is frequently an untrue concept, both in wealthy and developing nations. [29] For instance, people are still residing in "temporary" prefab homes from World Wars I and II in Britain. The refugees from Asia Minor who arrived in Greece in 1928 provide yet another example with a large depth of time. There, homogeneous prefabricated home used as temporary shelter is still occupied more than 50 years later and by three generations. [30]

The temporary homes constructed in Managua, Nicaragua, following the 1976 earthquake, became permanent. The initial buildings were one room, 15 feet by 15 feet, with crude timber siding, corrugated metal roofs, dirt floors, no electricity or plumbing, and shared outhouses and community water amenities. The effort to enhance the units—or make them permanent—was extremely slowly carried out in spite of an improvement loan, and as of 1977, the community had major sanitary issues and a high prevalence of malaria. (in any given period, malaria affected 50% of the population in this location.) [31]

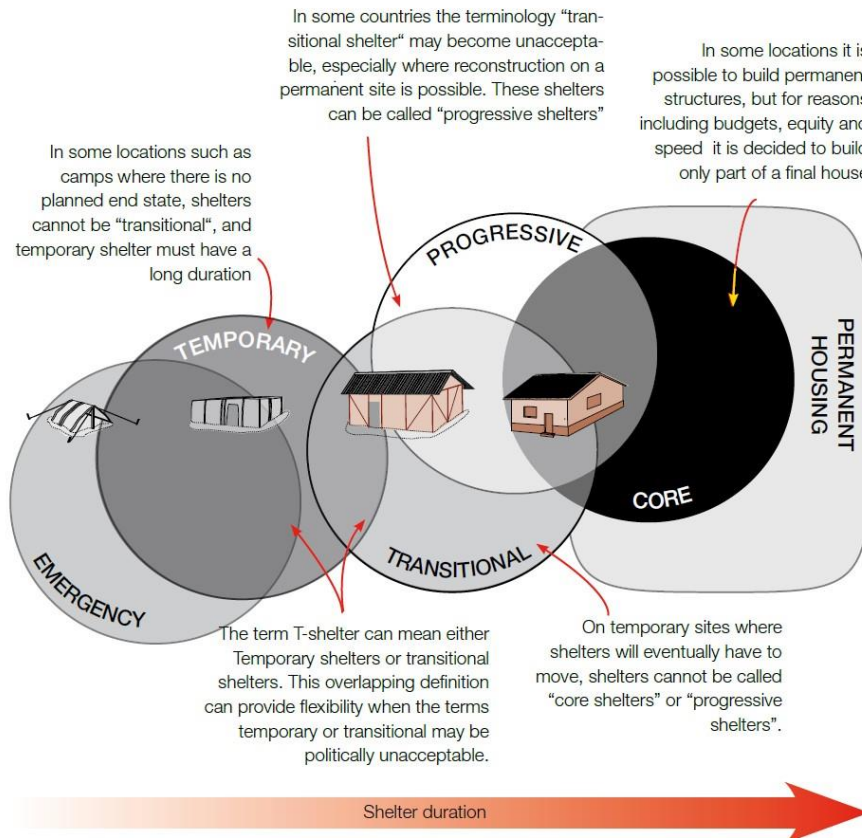

Figure 2: Overlaps between different shelter terminologies. [28]

# State of the Art

## Historical Review of the Post disaster Housing Solutions

It is important to look at the post-disaster housing options that have been documented by the concerned parties for numerous recent disasters. This helps to determine which major issues have come up more frequently and which may require creative solutions.

The need for sufficient shelter during their travels from one location to another led to the development of emergency housing, which is related to the needs of nomadic people. These were first represented by improvised locations, such as caves, and subsequently by transient homes. Using the materials at hand to build temporary constructions with qualities like durability and resilience to climatic conditions, nomadic people developed various shelter options based on their geographic location and environment. These shelters also needed to have characteristics that would make transporting and putting them together simple, such as being lightweight and having simple component connections.

The Aurignacian houses, which get their title from the French Aurignac cave, are among the earliest examples of habitation from the Palaeolithic period. This hut was built to support itself. The branches that were embedded in the ground in a circular pattern, with their upper ends curving towards the center and joined together, served as the dome's fundamental structural component [32]. The covering, frequently made of leather, covered the frame. The Maddalenian hut, which gets its name from the La Madeleine cave in Tursac, Dordogne (France), follows the Aurignacian hut, which dates back between 39.000 and 21.000 years. In this instance, the building was composed of wood and had a double-pitched roof. The center stiffening was achieved thanks to poles and stitched leather covering [33].

Paleolithic housings have inspired the most popular nomadic dwellings, i.e., tents. Made with a framed supporting structure covered with fabrics or leathers tended by tie-rods, the tent had to adapt to different climates, although it presented structural variations characterizing different populations.

Among the most widely used types of tents, the Yurt – used until today – was technically more advanced from lightness and prefabrication points of view [34]. This type of shelter was originally used during the trips by the Turkish and Mongolian tribes [35].

The self-supporting Yurta structure had a circular base with a diameter of four to ten meters and a height of around three meters. The main framework was made out of a trellis of curving pieces that had been linked together in a lozenge arrangement. This conformation enabled a "pantograph" lock, enabling quick disassembly of the structure, a decrease in the weight during transit, and simple assembly. The trellis components' ends came to a point in a covering ring that was left free to allow heat to escape. This ring might be covered by drapes at night or during the coldest weather. A Yurt typically weighed 250 kg, and its many parts might be categorized into five or six sections to ease the transport, supported by wagons or animals [36].

Originally, yurt materials were flexible willow timber for the structure and vegetable wicker or felt for the covering throughout the summer and winter, depending on the resources available. Technical controls were used to regulate the inside microclimate; the chimney effect created by the mentioned hole prevented the buildup of smoke in the winter and permitted ventilation

in the summer.

## **Real life Approaches and Designs for Temporary Housing Solutions**

Temporary housing might be the solution to the post-disaster housing problem. Temporary housing can be deployed at the early phase of recovery and be built to last longer than emergency and temporary shelters. It can be transformed into permanent housing the affected community has to stay in once the disastrous event fades down.

For the above-mentioned reasons, it is important to meet community needs and provide some form of normalcy during post-disaster times. However, the word "temporary" can mean a long time, which refers to how long it takes to recover from any disastrous event. Displaced survivors may live in a temporary disaster relief shelter for months, perhaps even years. It's essential to keep in mind that communities stay in shelters longer than anticipated. Therefore, the housing should provide enough comfort, privacy, and security for the community to stay healthy and maintain stable well-being.

While there have been many different types of temporary housing around the world, an ideal solution to the problem still has not been found. One of the factors complicating the problem is the intended use of the shelter. Temporary housing may be in use for a few weeks or may go up for months or years. Past cases of temporary housing from across the globe reveal that what initially starts as a temporary shelter for a short period of time may end up being used for many years following the incident, years to even decades in some cases [37]. Hence, it is vital to plan a temporary housing solution that can be used for a longer period of time with the ability to be re-used in case of provision of permanent housing or to be incorporated into the permanent housing solution.

Temporary housing can be broken down into two broad categories: prefabricated kit supplies and prefabricated ready-made shelters. The benefits of prefabricated kit supplies are easy transportation and possible local/volunteer construction efforts. On the other hand, while prefabricated ready-made shelters are hard to transport, they can be more quickly integrated into the emergency effort due to their preconstruction. [38]

There are some real-life examples and designs for temporary housing both in academic and non-academic literature.

### **Developing Countries**

#### **Post Disaster Housing Solution in Haiti**

According to statistics from the Inter-American Development Bank, the M 7.0 earthquake that hit Haiti on January 12, 2010, is proportionately the worst tragedy to affect any country in modern times in terms of fatalities. Although the exact number of fatalities is still unknown, the official estimate was about 220,000[39]. Almost all of the country's 9 million citizens have been impacted, either directly or through indirect means. Port-au-Prince, the capital of Haiti, was completely destroyed, and severe infrastructure damage was still present in the affected area one year after the earthquake.

Around 80% of Haiti's schools were either completely destroyed or severely damaged. The Haitian government estimates that approximately 300,000 homes were either destroyed or damaged. Since the earthquake in January 2010 and the subsequent aftershocks, survivors of

the quake have been at risk for additional dangers such as landslides, debris flows, flash floods, tropical storms during the rainy season and hurricane season, and a cholera outbreak that started in the autumn of 2010. [40]

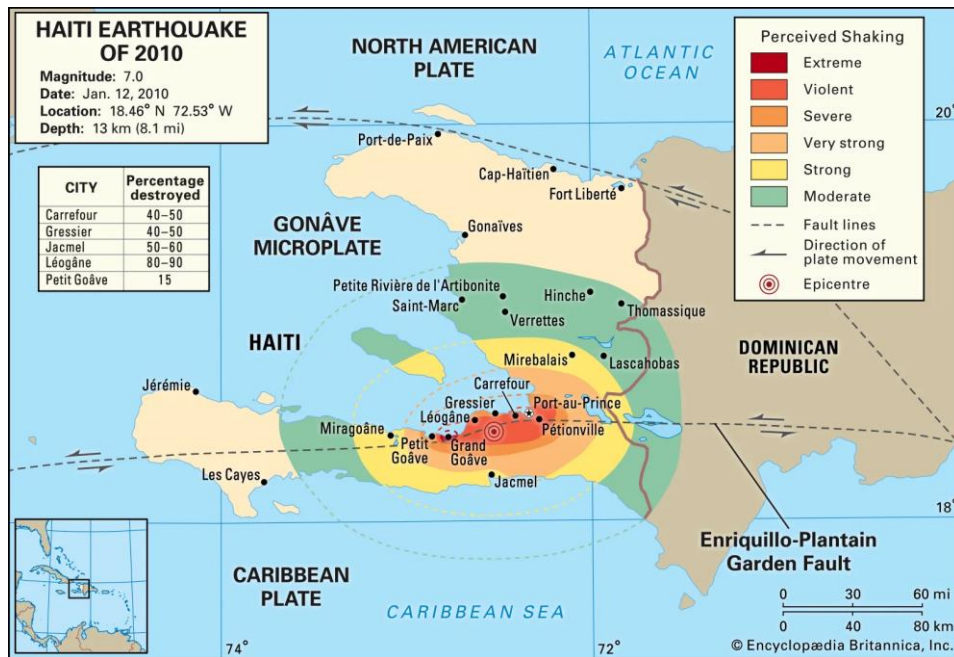

Figure 3: Map of Haiti Earthquake [39]



Figure 4: Emergency Shelters Provision After Disaster [39]

One of the prominent designs had been suggested by Humanitarian House International (HHI), a nonprofit organization. After the 2010 earthquake in Haiti, which put over a million people homeless, HHI sought to provide an affordable, easily assembleable temporary housing solution. The two possibilities in the model they created were an emergency shelter (ES) and a long-term dwelling (LTD) that might endure up to ten years.

PVC tubes, prefabricated wall panels, and fasteners were the main components of both designs. Their approach is intriguing since it allows for the upgrade of an ES to an LTD unit if necessary. Four years after the devastating earthquake, there were still 172,000 people in Haiti living in temporary accommodation, according to estimates [37]. Additionally, installing kitchen and



bathroom fixtures is an option that may be added before or after the update. The model was created to incorporate solar power systems, waste management techniques, and systems for harvesting rainwater [38].



Figure 5: Temporary Shelter Solution By HHi [84]

### Post Disaster Housing Solutions in Turkey

A temporary housing site was established in Duzce following the 1999 earthquake in Turkey that caused 600,000 people to flee their homes. In reaction to the accident, 63,500 temporary dwellings were built [42]. The overwhelming number of displaced individuals, along with the demand for housing and other infrastructure, highlights the necessity for proactive planning as opposed to reactive, haphazard construction. In essence, the population, as well as the number of homes in the country's existing cities, was equivalent to the number of temporary dwellings in the housing camp.



Figure 6: Map of Earthquake, Turkey [43]

The temporary housing project piloted the use of recycled materials to create the housing, and



designs enabled housing units to be either deconstructed or upgraded to full-time residences should the need arise. Each shelter had the ability to replace its “temporary” aspects with more permanent ones through deconstruction. The deconstructed material was then used for either permanent reconstruction or recycling. The introduction of smart design in temporary housing provides a sustainability aspect that can be applied to other types of temporary and emergency housing [42].

Houses in Fevzi Cakmak, which were made by the Disaster Work General Directorate, were of double-house type. Constructions were made by a panel system. The panels that formed the interior and exterior walls were made of cement and wood shaving mixtures named chip panels. The sizes of the house were 5.5x10.60 m, approximately 30m<sup>2</sup>. There were no transportation problems for the site. The houses were used for 3 years. [43]

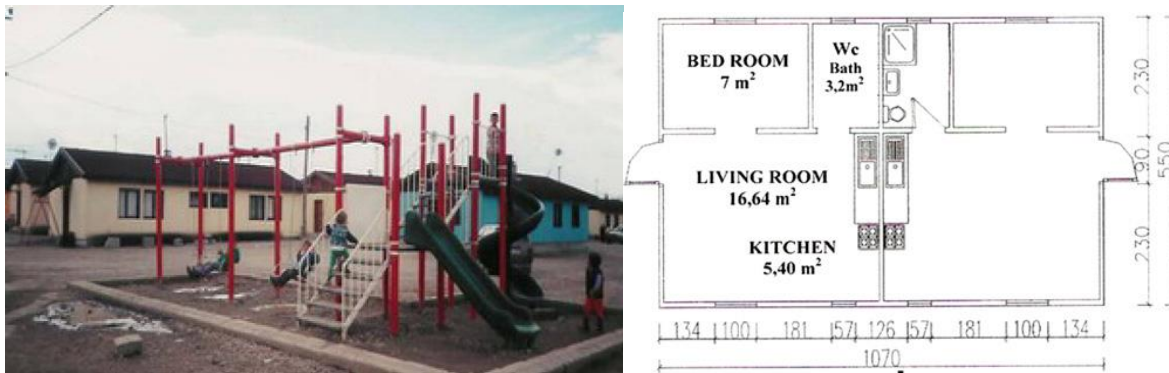

Figure 7: Fevzi Cakmak temporary housing site [43]



Figure 8: GumusPinar Temporary Housing Site [43]

Houses in GumusPinar were double-house type and constructed with a panel construction system. The exterior walls were made from zinc–aluminum panels and the interior walls were made of cement–wood shavings mixture chipboards. The house sizes on the site were 5.5x10.60m and approximately 30m<sup>2</sup>. There is a primary school with 24 classrooms, a village clinic, a security-safety unit, a day nursery and cafe, a bakery, and a grocery, which is run by the private sector. [43]

### Post Disaster Housing Solutions in Iran

Iran is situated on the world's dry belt, which is made up of 60% mountains and 40% desert

and arid plains. It is a country that frequently suffers from severe earthquakes, droughts, floods, landslides, desertification, deforestation, storms, and other natural disasters. Iran has experienced 31 of the 40 various types of natural catastrophes that may be seen across the world. [44]

As one of the seismically active nations in the world, Iran is traversed by a number of significant fault lines that span at least 90% of the nation. [45] More than 5 million people die from earthquakes each year, 20 times more than from volcanic eruptions. Many people require urgent medical attention. [46]

In northern Iran, the 1997 Ardabil earthquake claimed 1,100 lives, injured 2,600, left 36,000 people homeless, damaged or destroyed 12,000 homes, and killed 160,000 animals. Tents constructed to serve as effective emergency shelters. [47] [48]

According to the Iran Geophysics Centre, a series of earthquakes on March 31, 2006, with the largest shock registering 6 on the Richter scale, rocked southern Iran, including the Borujerd and Dorud districts in Lorestan Province, resulting in 63 fatalities and 1418 injuries. In the eight impacted towns and 320 villages, around 33,000 structures sustained damage of more than 50%, and 6000 animals perished. The first rescue and relief teams were sent out to assess the magnitude of the devastation and the level of help needed. On the first day, 52,200 tents were delivered in total. [48]

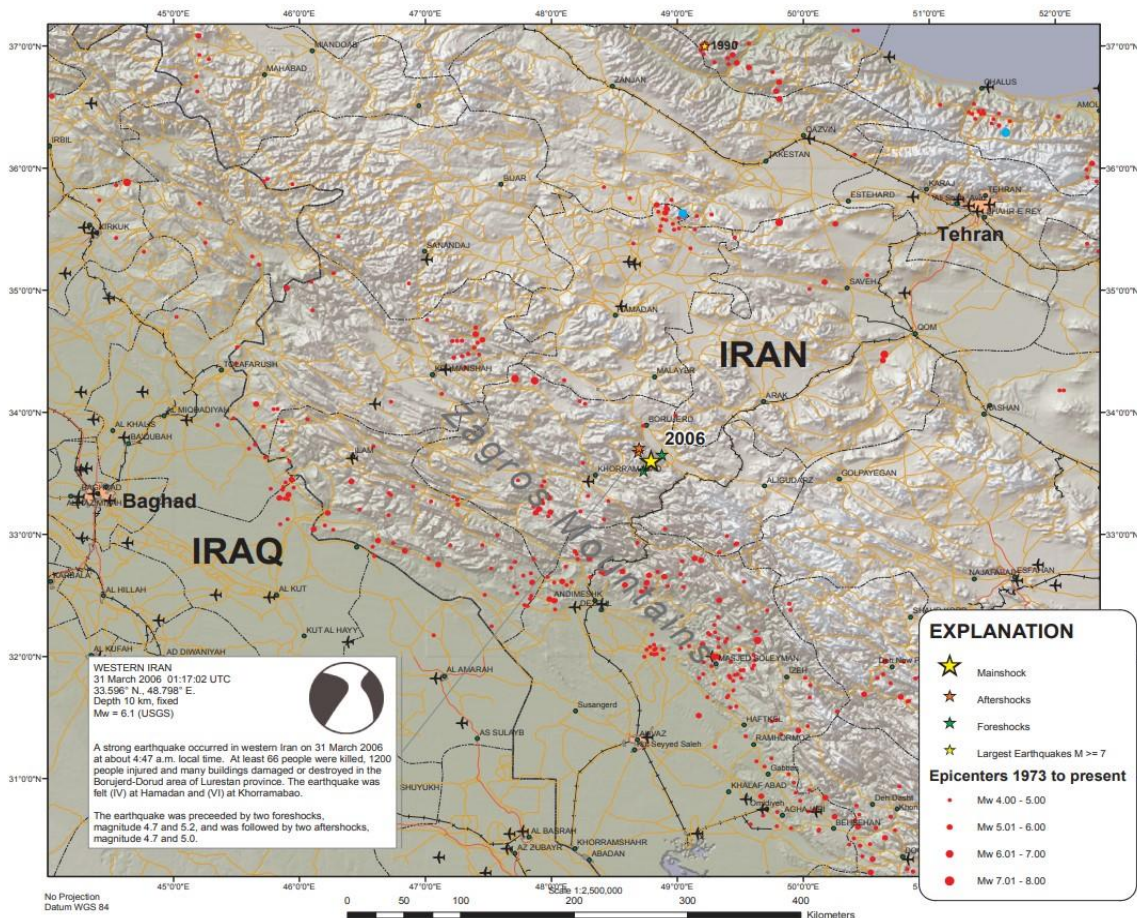

Figure 9: Map of Earthquake, Iran [85]



IRCS distributed tents in the villages of 2nd priority area and 3rd priority area in collaboration with local authorities, and 3050 tents were given to the municipality of Borujerd for distribution. [49]

The government decided to conceal the temporary housing stage at Lorestan after two earthquakes due to suitable conditions for the reconstruction process, unaffordable experience, and unsolved problems from past quakes like Bam, and encouraging people to catch the recovery process.

Concealing the Temporary Housing Stage at Ardabil was done for several reasons, including reducing the cost of the reconstruction process and encouraging people to catch up with the recovery process.

After the Lorestan and Ardabil earthquakes, decision-makers concealed the temporary housing stages without communicating these ideas with survivors and experts. This choice was made with the intention of maximizing building speed. However, due to parameter constraints, it wasn't completed in the next two years. Temperature (Lorestan has a very hot temperature, whereas Ardabil has a chilly one), the length of the housing process (which took longer than they anticipated), and the degree of involvement of the population (which was hidden during the recovery process) all had an impact on the restoration process. [49]

### **Post Disaster Housing Solutions in Philippines**

Tropical cyclones have struck the Philippines several times over the years. Typhoon Yolanda (Haiyan), which struck the Philippines in 2013, caused the worst destruction in recorded Philippine history and claimed at least 6,000 lives. It affected 14 million people. [50] Disasters caused by climate change, such as tropical storms, flooding, earthquakes, and volcanic eruptions, cause damage to shelters every year in the Philippines. Each year, catastrophic disasters harm 300 shelters on average. When it made landfall in Eastern Visayas in 2013, Super Typhoon Yolanda (international name: Haiyan) killed over 6300 people and damaged almost 1.14 million homes. [51]



*Figure 10: Post Disaster Destruction, Philippines*  
[86]

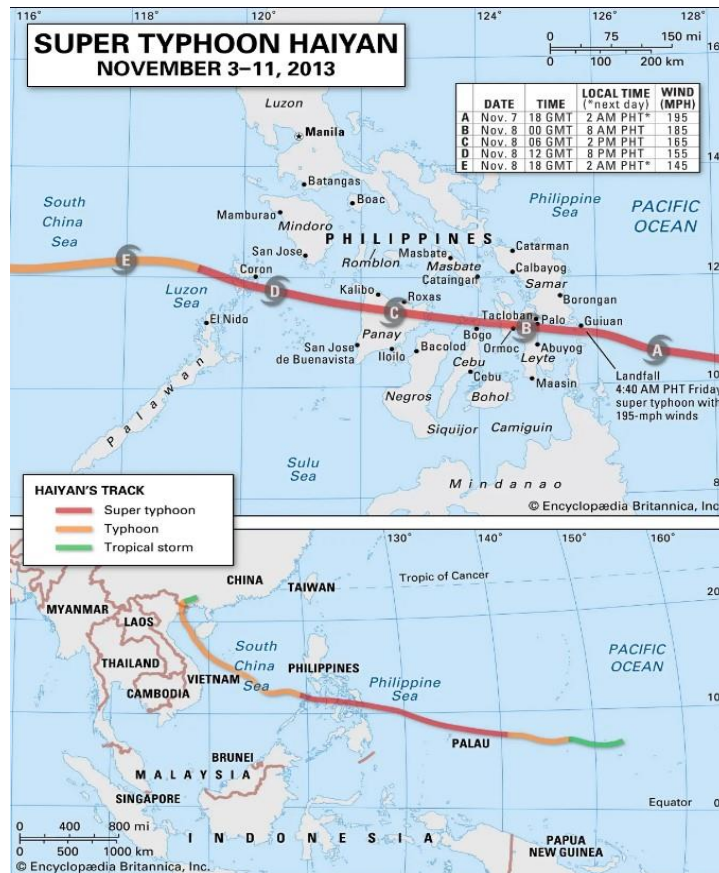

Figure 11: Map of Typhoon Yolanda [87]

The national government, through the Department of Public Works and Highways (DPWH), had begun construction on 121 of the 222 temporary shelters or bunkhouses for the thousands of families who had been displaced after a month of the super typhoon Yolanda's onslaught. The 24-unit bunkhouse is designed for families of three to four people and has a floor size of 8.64 square meters. The bunkhouses were situated in Tacloban City, Palo, Leyte, Basey, and Marabut in Samar, which were all badly hit. In order to host as many families as possible, a total of 248 bunkhouses were constructed, with each bunkhouse being divided into 24 rooms [52].

According to the DPWH, the bunkhouses are anticipated to be structurally sound for two years until the government completes the building of permanent shelters. In the middle of this, the building of these temporary shelters was dogged by accusations of overcharging and poor quality due to collusion between contractors and politicians who received commissions of between 30 and 35 percent of the contract cost. [52]

Aside from this, an international organization pointed out the inadequacy of bunkhouse compliance with internationally recognized standards and practices with respect to safety and decency of living, such that the standard of space occupancy is 3.5 square meters per person. [53]



*Figure 12: Bunk Houses  
[88]*

One of the noticeable temporary shelter designs deployed was the Paper Temporary Shelter. It was designed by architect Shigeru Ban and constructed in Cebu, Philippines, after the devastation of Typhoon Haiyan in November 2013. Ban streamlined the shelter's general architecture and sped up construction by using connection techniques like those found in his paper partition system, which was designed to create separation and seclusion within evacuation shelters. Each shelter is supported by a base built of a series of sandbag-anchored plastic soda and beer crates, which are then lined with plywood and coconut wood floor panels. Then, to build vertical walls, prefabricated woven bamboo sheets were put on top of the paper tube structural frame. Finally, plastic sheets were covered with Nyla palms to form a thatched roof. [54]



*Figure 13: Paper Temporary Shelter  
[89]*

The tables below provides a summary of the data related to the disaster and temporary housing provisions under discussion.

<b>DEVELOPING COUNTRIES DISASTER SUMMARY</b>					
<b>Disaster</b>	Haiti Earthquake	Duzce Earthquake	Ardabil Earthquake	Lorestan Earthquake	Typhoon Yolanda (Haiyan)
<b>Year</b>	January, 2010	November , 1999	February, 1997	March, 2006	November, 2013
<b>Source</b>	Perrucci et al. [39]	Arslan [42]	Mansouri et al. [44]	Hadafi et al. [49]	World Bank [50]
<b>Location</b>	Southwest Port-au-Prince	Gölcük, Turkey	Ardabil, Iran	Lorestan, Iran	Philippines
<b>Severity</b>	7 on the Richter Scale	7.2 on the Richter Scale	6.1 on the Richter Scale	6 on the Richter Scale	Category 5 Typhoon
<b>Damage</b>	- 300,000 houses destroyed or damaged. - 700,000 people displaced.	- 43,000 buildings destroyed or damaged. - 600,000 people displaced.	- 12,000 houses destroyed or damaged. - 36,000 people displaced.	- 33,000 buildings damaged. - 15,000 households displaced.	- 1,012,790 houses destroyed or damaged. - 4 million people displaced.

*Table 1: Disaster Summary - Developing Countries  
(Source: Author's Own Compilation)*

<b>DEVELOPING COUNTRIES HOUSING PROVISIONS</b>						
<b>Location</b>	Southwest Port-au-Prince, Haiti	Gölcük, Turkey	Ardabil, Iran	Lorestan, Iran	Guigan, Philippines	Cebu, Philippines
<b>Organisation</b>	Humanitarian House International (HHI)	Ministry of Public Works & Settlements (MPWS) and General Directorate of Disaster Affairs (GDDA)	Bureau for Research and Coordination of Safety and Reconstruction Affairs (BRCSR)	Bureau for Research and Coordination of Safety and Reconstruction Affairs (BRCSR)	Department of Public works and Highways (DPWH)	Shigeru Ban
<b>Year</b>	2010	1999	1997	2006	2013	2013
<b>Disaster</b>	Haiti Earthquake	Duzce Earthquake	Ardabil Earthquake	Lorestan Earthquake	Typhoon Yolanda (Haiyan)	Typhoon Yolanda (Haiyan)
<b>Construction Time</b>	>1 day	-	-	-	-	10 hours
<b>Size</b>	178 sq. ft.	323 sq. ft.	-	-	-	172 sq. ft.
<b>Spaces</b>	Storage, Daytime living, Nighttime sleeping	Kitchen, Bathroom, Living room/ Bedroom	-	-	Sleeping Space	Sleeping Space
<b>Capacity</b>	3-4 adults	5	-	-	3 - 4 people	
<b>Assembly</b>	Kit of parts	Pre	-	-	-	Kit of Parts



	Plywood Sheets	Fabricated cement and wood shaving mixture named chip panel for internal walls,				Roof thatching of nypa palms over plastic sheets  Foundation of sand filled soda crates  Paper tube frames + woven bamboo sheets and ply walls
--	----------------	---	--	--	--	--

*Table 2: Shelter Summary - Developing Countries  
(Source: Author's Own Compilation)*

## **Developed Countries**

### **Post Disaster Housing Solutions in USA**

Storm Katrina (August 2005) developed into a sizable and extraordinarily potent storm that caused major property damage and fatalities. It surpassed Hurricane Andrew in 1992 as the costliest hurricane ever to make landfall in the United States. Moreover, Katrina was among the five most deadly storms to have hit the United States. Overall, Hurricane Katrina caused \$108 billion in damage (in unadjusted 2005 currency) and 1,833 fatalities. [55]



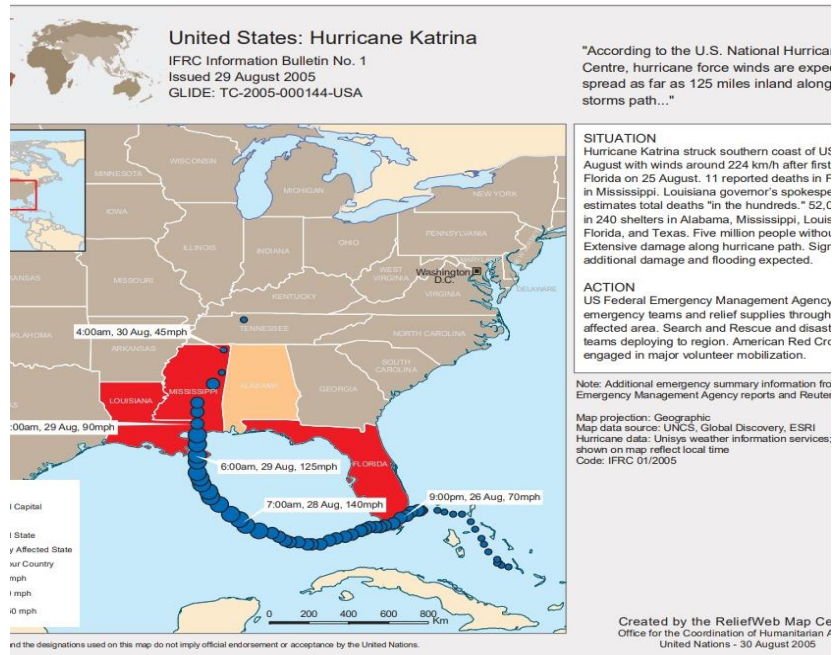

Figure 14: Map of Hurricane Katrina [82]

Hurricane Katrina gave us insight into how well the United States can handle a catastrophe of this scale. First and foremost, the terrible natural catastrophe and its aftermath exposed the infrastructure's fragility and forced FEMA to get ready for future calamities, leading to the creation of the National Catastrophe Housing Strategy for the United States.

The post-hurricane emergency housing consisted of two main options that were designed to be used for only 18 months. The first option was a temporary travel trailer; these travel trailers were found ineffective due to their shorter-than-expected life expectancy, use of unsustainable materials, and their negative impacts on human health due to high concentrations of indoor volatile organic compounds and low air exchange rates [56].



Figure 15: Temporary Trailers [90]

However, FEMA had also provided 25,000 Structural Insulated Panel homes that utilized prefabricated insulated panels to provide energy efficiency and durability. The housing units had 3 bedrooms and 2 bathrooms each and could be joined together to create a larger unit. In addition, photovoltaic systems could be integrated to provide power. Although these temporary houses were not intended for long-term use, having a life span of 18 months, about 60,000 people were still living in their temporary homes two years after the disaster. The popularity of these shelters has surpassed the disaster, and they are labelled now as Katrina Cottages [57].



*Figure 16: Katrina Cottages  
[91]*

In the case of FEMA's response following Hurricane Katrina, the initial homes provided had a shorter actual lifetime than the design lifetime and emitted harsh chemicals into the indoor environment where there was already a lack of air circulation. In the end, the disaster revealed the vulnerability and lack of resilience of the state. Soon after, the National Disaster Housing Strategy was developed by FEMA. [57]

#### **Post Disaster Housing Solutions in China**

As the world's second-largest economy, China is vulnerable to many natural and man-made disasters. In 2018, natural disasters affected approximately 1.3 billion people, killing 589 while having 524.5 million urgently relocated. [57]

In China, the great interest in post-disaster temporary housing originated in the Wenchuan Earthquake and its aftershocks in 2008, which destroyed a large number of buildings and left millions of people homeless. It was estimated that the economic loss ran higher than US\$75 billion, making the earthquake one of the costliest natural disasters in Chinese history. The severe damage caused by the earthquake brought a massive increase in the number of disaster shelters, as residential buildings accounted for 27.4% of the total loss. [58]

The 2008 Wenchuan earthquake was the severest large-scale earthquake disaster in China in the past sixty years. After the earthquake, the governments of China faced a very difficult mission to provide a large number of temporary shelters for the five million homeless victims within only three and a half months. [58]

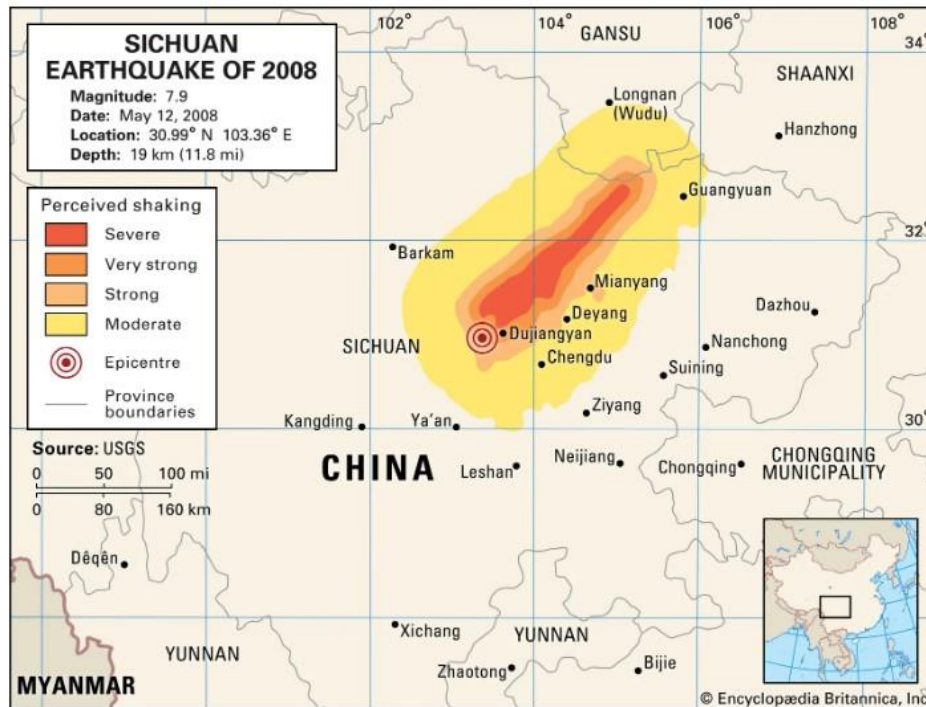

Figure 17: Map of Sichuan (Wenchuan) Earthquake [92]

Happy Homeland, with an area of 10 hectares, was one of the typical biggest temporary settlements in Dujiangyan, a severely afflicted area in the hot summer and cold winter zones. This settlement consisted of three similar zones of A, B, and C, had 2585 standard rooms in total, and could accommodate about 6,700 homeless. Hence, this settlement had a high building density, which was very common in the earthquake-stricken area.

Every prefab house featured a single story and a number of basic rooms in order to save time, money, and building materials. As illustrated in the figure, each typical room was constructed of 100mm thick EPS board and included two windows that were placed 1m above the floor in the front and back walls, respectively. These prefabricated homes' design was extremely typical of the areas left in ruins following the Wenchuan earthquake. The gaps between rows and lines were designated as streets and corridors, respectively. [59]

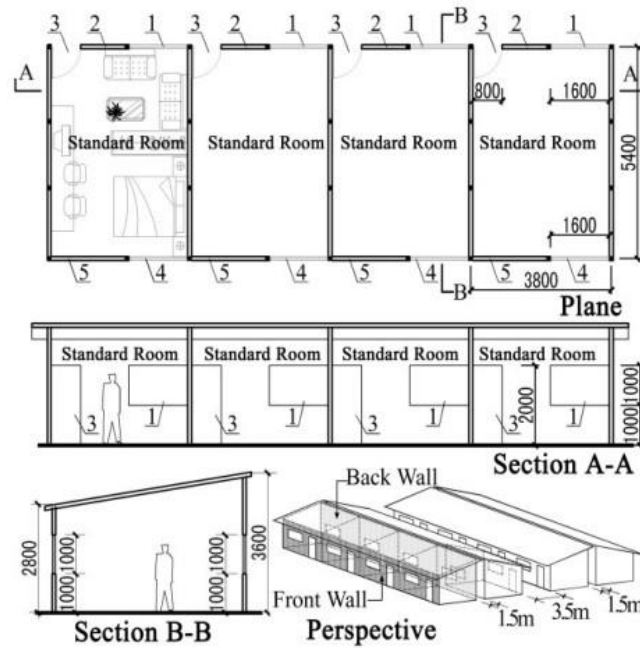

Figure 18: Happy Homeland [59]

The average monthly temperature of the warmest month in Dujiangyan, which is in the hot summer and cold winter region of China, is between 25 and 30 °C. As a result, the interior thermal environment in the hot summer and cold winter zone would be worse in the summer than in the winter. Additionally, due to the densely packed construction, the wind velocity inside the settlement was lower compared to the outside. The micro-scale heat island effect would further worsen the settlement's summertime interior and outdoor temperature settings. Therefore, thermal pressure ventilation appeared to be an essential technique to enhance the thermal environment, even though it was much more difficult compared to cooling the temporary dwelling by wind pressure ventilation. Consequently, the temporary house was redesigned using architectural techniques. [59]

Additionally, the hottest month's average temperature in China's hot summer and warm winter regions ranges between 25°C and 29°C. The hot summer and mild winter regions of China will also experience the summer's abhorrent interior and outdoor temperature settings of Happy Homeland. Therefore, it was crucial to enhance the design and architecture of a community with a lot of buildings, like Happy Homeland. [59]

The tables below summarize the data related to the disaster and temporary home provision under discussion.

<b>DEVELOPED COUNTRIES DISASTER SUMMARY</b>		
Disaster	Hurricane Katrina	Wenchuan Earthquake
Year	August, 2005	May, 2008
Source	Thompson et al. [25]	Song et al. [58]
Location	Southeastern United States	Sichuan, China
Severity	Category 5 Hurricane	8 on the Richter Scale
Damage	- 800,000 people displaced. - 214,700 damaged houses.	- 5 million - 11 million people displaced. - 5 million damaged buildings.

*Table 3: Disaster Summar - Developed Countries  
(Source: Author's Own Compilation)*

<b>DEVELOPED COUNTRIES TEMPORARY HOUSING PROVISIONS</b>		
Location	Louisiana, United States	Sichuan, China
Organisation	FEMA	Happy Homeland
Year	2005	2008
Disaster	Hurricane Katrina	Wenchuan Earthquake
Construction Time	2-3 days per cottage	-
Size	308 sq. ft. - 1807 sq. ft.	1.076 sq. ft.
Spaces	Bedroom, Living space, Bathroom	living space



Capacity	Upto 4 people / cottage	6,700
Assembly	Pre. fabricated  light gauge steel for the roof, flooring, and studs.  Factory made wood panels for partitions	Pre. fabricated  Steel Frame  EPS board Panels for partition

*Table 4: Shelter Summary - Developed Countries  
(Source: Author's Own Compilation)*

## **New Approaches to Sustainable Housing Solutions**

In the search for an ideal solution, a number of new approaches have been proposed related to sustainable housing solutions for disaster-stricken areas. Different technologies and methods have been proposed, such as 3-D printing, General Purpose (GP) shipping containers, and Modular Systems.

### **G.P Shipping Containers**

Due to their resilience to weathering, general-purpose (GP) shipping containers have emerged as a practical choice for enabling the rehabilitation of devastated areas. The abundance of empty containers is a cost-effective and long-lasting answer to the issue of emergency housing. Due to their modular and consistent design, these shelters also include simplicity of mobility, which is crucial in times of emergency. They may be moved by trucks, trains, and ships. Additionally, they provide the capability of being merged to expand the shelter's living space. The capacity to recycle or reuse the buildings or their components is the main advantage of using GP cargo containers as temporary housing.[60]

The utilization of shipping containers (SCs) as temporary shelters is a practical solution. Steel SCs are sturdy, secure, and long-lasting. A variety of rigorous tests are performed on each produced container, including static load, dynamic load, stacking, and "weatherproofness" or water tightness [61]. SCs are also stackable, modular, and prefabricated. They are readily available and basically compatible with every form of transportation. In addition, SCs are inexpensive compared to conventional building materials and are widely accessible worldwide. SCs are a suitable building material for making temporary shelters because of their qualities. In reality, modified SCs have been created by architects and engineers all throughout the world as substitutes for homes, offices, retail spaces, and classrooms [62].

The use of shipping containers as housing presents both advantages and disadvantages. On the one hand, shipping containers are essentially large, uninsulated boxes with no openings to allow light and air to enter and circulate. Although there are some insulated containers used for temperature-controlled product transportation, the vast majority of containers have no

insulation and are referred to as GP containers or general-purpose containers.

Since there is no insulation and the walls are relatively thin, these containers are not soundproof. GP shipping containers may also present other disadvantages, based on their previous use, if they encounter cargo spillage or chemicals used to paint and seal their plywood floors. However, these setbacks can be easily overcome. On the other hand, shipping containers allow for modular design, providing ease of transport by ship, rail, or truck. Used shipping containers are available anywhere around the world from many distributors, and they are built to adhere to the strict rules of the International Organization for Standardization (ISO). [63]

### **Container Temporary Housing, Japan**

The earthquake and tsunami in East Japan in 2011 devastated many homes in the northern Tohoku region of Japan. One of the communities affected was a small fishing town on the northern side called Onagawa.

After the Onagawa earthquake in Miyagi Prefecture in 2011, architect Shigeru Ban created the Container Temporary Housing to alleviate the housing crisis. The ports, several fishing settlements along the coast, and numerous residential areas of the town were all destroyed by the tsunami. 27 The objective of the concept was to swiftly and affordably build temporary housing that would meet everyone's needs. Ban arranged shipping containers in a checkered layout to achieve this. [64]



*Figure 19: Container Temporary Housing  
[93]*

Shigeru Ban's design team planned three types of plans: six tsubos, nine tsubos, and 12 tsubos (A tsubo is a Japanese unit of area equal to approximately 3.31 square meters). The layout of the spaces in these three types was made to accommodate single or couples, families of four, and families with more than four, respectively.

The Voluntary Architects Network (VAN) also created built-in furniture, such as wall-mounted and floor-standing storage shelves in each unit. A design firm of engineers, architects, and technical specialists, Arup assisted architect Shigeru Ban in the structural aspects of the design for the shipping container housing. Compared to most temporary housing, these container

houses were more resilient and provided higher sound insulation. The structure was also built to be disassembled and transported with ease to reuse in other disaster-stricken areas if needed or even converted into permanent housing. The construction was completed in 14 weeks. [64]



*Figure 20: Housing Plans  
[93]*

Using shipping containers made the assembly quick due to the prefabricated units, therefore cutting construction costs. Shigeru Ban's design was created in response to the needs of the people. The homes and community spaces designed for them were built such that the people felt at ease with their surroundings and allowed them to return to their routines, even though it was only temporary. After its use as temporary housing, the container structures could also be reassembled later as permanent structures [64]

The use of modified shipping containers is not yet widespread in post-disaster temporary housing applications. Much knowledge exists about using shipping containers in housing applications, yet, for the most part, approaches inadequately address the multifaceted economic, social, and logistical issues inherent in using shipping containers as dwellings, and few focus on the additional complexities associated with post-disaster temporary housing. [36]

### **Future Shack, Australia**

Another example is the Future Shack, developed by an Australian architect, Sean Godsell, which was one of the first attempts to utilize shipping containers in temporary housing.

The Future Shack is an ingenious response to the urgent need for emergency and relief housing. Utilising recycled shipping containers as its core building blocks, this versatile design offers a scalable solution for various scenarios, including natural disasters, temporary housing, and remote locations. Its mass-produced and cost-effective nature, along with its ease of transportation, makes it readily available worldwide. Notably, the telescoping legs and self-contained features reduce the dependency on extensive site preparation and infrastructure. The inclusion of essential amenities such as water tanks, solar power, and adaptable ablution options enhances its suitability for diverse environments. With its distinctive parasol roof, the Future Shack not only symbolizes home but also provides shade and thermal comfort, making it a practical and sustainable housing choice that can be quickly assembled on-site within 24 hours. [65]





*Figure 21: Exterior & Interior, Future Shack  
[94]*

There are logistical benefits to deploying general-purpose shipping containers as temporary residences in disaster-affected areas, but there are also a number of disadvantages. These containers feature a small interior, which may not be enough to comfortably house families or bigger groups. Their lack of insulation might make living conditions difficult during harsh weather. In humid or warm locations, ventilation can also be a concern, perhaps affecting the quality of the air. [62]

Moreover, as steel possesses a high thermal conductivity, heat is a serious issue when employing SCs as housing. Additionally, moisture can cause condensation on steel. When selecting shipping containers for temporary housing in disaster relief operations, it's critical to balance these drawbacks with the positives. [66]

### **3-D Printing**

3-D printing of houses or component parts is a technology that has the potential to be used for temporary shelters. There are currently several examples of 3-D printing in the building business, albeit more study is needed to create shelters, temporary housing, or their pieces. The key benefits of this technology would be a decrease in building time, a drop in labor expenses, and a reduction in manufacturing waste. [67]

In that sense, the technology could prove to be the environmentally preferable alternative due to its ability to reduce waste and recycle or downcycle construction materials. 3-D printing and manufacturing shelters on-site at the disaster region could prove to be more feasible and practical than shipping containers or parts across long distances should the technology further progress. [38]

Technological advancements have been identified as a possible solution for supporting and bolstering disaster management operations. [68] 3DP, which is also referred to as additive manufacturing, will change the construction industry - from high-rise buildings to temporary shelters. [69]

Additive manufacturing refers to automated methods that are used to build objects in layers of different materials, such as plastic, cement, metal, or any other substance, directly from a digital design file stored on the 3DP. [70]

These methods include the laser strengthening of liquid polymer, laser melting of metal powder, and extrusion of molten plastic into solid objects. 3DP is an automated activity that could decrease the carbon footprint, cost, and duration of construction while increasing labor safety and efficiency [71][72]

In terms of materials, plastics, metals, ceramics, and sand are now routinely used in industrial prototyping and production applications. Materials available for 3D printing have come a long way since the early days of technology, and there is now a wide variety of materials that are supplied in different states (powder, filament, pellets, granules, resins, etc.) [73]

The 3DP technology implemented is believed to provide disaster-resilient homes more efficiently than traditional houses, which could be beneficial in times of floods, fires, hurricanes, and other natural disasters. [72]

#### **Apis Cor House**

In 2017, Apis Cor, a Russian company, constructed an entire functional house in 24 hours. Using their unique 3D printing technique, which enables them to 3D print buildings with no mobility or size limits and little to no human contact, the 3D printed house was totally constructed on location. This is made possible by the 3D printer's tower crane setup, which prints from within the model home. A standard truck can easily move the Apis Cor system, which comprises a mobile 3D printer and a mobile automated mix and supply unit, to a site. On-site commissioning takes no longer than an hour. According to the company, the technology saves up to 25 to 40% of building construction costs in comparison to traditional construction with labor-intensive construction methods. This is achieved due to manual labor minimization, process automation, and faster construction time. Additional benefits of the technology are the lack of waste material and new architectural capabilities. [74]



*Figure 22: Apri Cor House  
[95]*

### **Gaia - Earth House**

In 2018, an Italian company, WASP, short for "World's Advanced Saving Project," inspired by the potter wasps or mason wasps, commissioned a project named "Gaia." The project is aimed at eco-sustainability by using natural materials such as soil consisting of clay, silt, and sand and natural waste materials such as chopped rice straw and rice husk in the construction of a 3D printed house. With the addition of vegetable fibers from the company RiceHouse, WASP has developed a compound consisting of 25% clay earth (30% clay, 40% silt, and 30% sand), 40% from chopped rice straw, 25% rice husk and 10% hydraulic lime which is mixed in a wet pan mill for homogeneity and workability. Because of the materials used, the house has bioclimatic characteristics such that the temperature inside is mild and comfortable throughout the year. It took the company 100 hours to 3D print the 40 cm thick wall of the project of 30 square meters building plan with 20 square meters of wall surface. It took the project 9 cubic meters of clay earth or 22 km of earth extrusion to finish the 3D printing of walls. The space between the exterior and interior walls and the diagonal stiffener walls is filled with rice husk as insulation material. The timber roof with rice husk insulation rests on timber columns and beams that are situated inside the clay earth walls. The project took 10 days to finish the house. The total material cost of the 3D-printed wall is €900. [72, 74]



**Foundation: Concrete**  
**Roof: Timber**



**25% Soil**  
**40% Straw**  
**25% Rice Husk**  
**10% Hydraulic Lime**

*Figure 23: Gaia – Earthhouse  
 [96]*

## **Essential Homes Research Project**

The Essential Homes Research Project is an idea created to quickly build a shelter for those displaced by both natural and man-made calamities. [75]

On May 17, during the 2023 Architecture Biennale in Venice, Holcim and the Norman Foster Foundation made the official announcement of the beginning of their Essential Homes Research Project. [75]

To make sustainable building accessible to everyone, Holcim used a variety of green building solutions in the Essential Housing Research project. The project gains resiliency and strength from its ECOPact low-carbon concrete. Elevate boards and Airium foam are only two of its insulation products that offer thermal and acoustic comfort to improve health. [76]

The cabin is constructed around a takeaway frame in two layers of canvas, one corrugated impregnated with low-carbon concrete. The outer layer is sprayed with water and starts to set within hours, is solid within a day, and the structure can be ready for safe, warm habitation in three to four days. [76]

The corrugated layer adds stability and creates space for foam insulation for colder climate housing. Another insulation layer is added underneath the concrete shell, while bedrooms, kitchens, showers, toilets, and dining tables are housed in easily inserted flat-pack plywood pods. [76]



Measuring 6m across and offering 18 sq. m of living space, each cabin could house a family of four, the project partners suggest. The modular, reconfigurable design means it could serve a range of other purposes, from office to store to school room. [76]



Figure 24: Exterior, Essential Homes  
[97]



Figure 25: Interior, Essential Homes  
[97]

Foundations are built using recycled demolition materials, while the cabins can be connected by low-carbon permeable pathways packed with light-absorbing, glow-in-the-dark aggregates, reducing energy use and light pollution. [75]

The component parts of the cabin arrived in Venice in a single truck, and the partners suggest they can make transport even more efficient in the future. No cranes are required in the construction, which can be completed by non-specialist teams, including future tenants. The cabins have also been designed for easy disassembly and then reuse or recycling. [75]

With a carbon footprint that is 70% lower than traditional structures, Foster and Holcim's model for a sustainable prefabricated dwelling is fully closed loop, as every component can be reused or recycled. [75]

With a current cost of €20,000 per cabin, the Foster/Holcim design isn't the cheapest solution to instant temporary housing, but the Essential Homes cabin can last at least 20 years, which means providing such a solution removes the need for permanent housing. Furthermore, the company is already looking at ways to reduce construction costs.

According to Holcim and Foster, the use of concrete is a hard sell to many young architects, but they insist that lower-carbon concrete is the most viable building material for large-scale projects. And that a priority in the project was using commercially available materials.

The project responds to the fact that displaced people often end up living in temporary accommodation for more than a decade and require homes that offer safety and dignity. [75]  
[76]

## DFMA Incorporation: Further Improvement

It is observed from the different examples from around the world that permanent housing can take years to realize after a disaster, while temporary housing could be provided in a matter of days. Modular construction with the incorporation of DFMA can drastically improve this time gap. The faster construction times, which are characteristic of modular construction, make this form of construction a great solution for providing faster houses.

Factors such as scarcity of resources, deficiencies in transportation, funding, etc., can still have a detrimental effect on the efficiency of modular construction. However, such factors can be expected in a post-disaster scenario. Modular construction can provide a more integrated approach where economies of scale that arise through mass production will provide a valuable solution to funding difficulties. As almost all the building components would be integrated into one single module before leaving the manufacturing plant, the disaster relief operation would depend on a single contractor instead of various contractors and subcontractors. This characteristic of modular construction will simplify the entire process of post-disaster housing. [77]

A great advantage of using modular structures as a post-disaster housing solution is that much of the expertise in reconstruction is directed to one solution provider. The expertise of appointed officers and institutions on the technologies involved is a key factor related to the speed of providing housing solutions.

Higher quality standards can be ensured due to the modules being constructed in a quality-controlled environment such as a manufacturing plant. Modules can be pre-engineered to perform at various climatic conditions in order to provide a better indoor climate to the dwellers. Better preparedness and having a set of modules that were prototyped previously with well-established production logistics can result in even faster delivery of final products. Techniques such as BIM can be used to efficiently gather and channel all such design requirements from a disaster-stricken community to the designers, and modular construction will be highly compatible with associating such requirements to produce custom-designed houses in a much faster time period. This is a great way to ensure that the livelihoods of the affected communities are restored to their satisfaction and to ensure that their basic human rights of housing are provided as early as possible.

### **DFMA Application to Temporary Shelters in Philippines**

A study was conducted to discuss the application of the Design for Manufacturing and Assembly (DFMA) methodology in the construction of temporary shelters in the Philippines.

The original design of the temporary shelter was based on the Philippine 2011 shelter from the International Federation of Red Cross and Red Crescent Societies' Ten Designs for Post Disaster Shelter. The shelter was constructed using reinforced concrete columns and foundations, masonry and timber walls, and timber roof framing with a dimension of 4.0m x 5.0m. It had a gable roof with a braced column height of 2.40m. The shelter took 12 days to be built and had an anticipated lifespan of 5 years. [51]

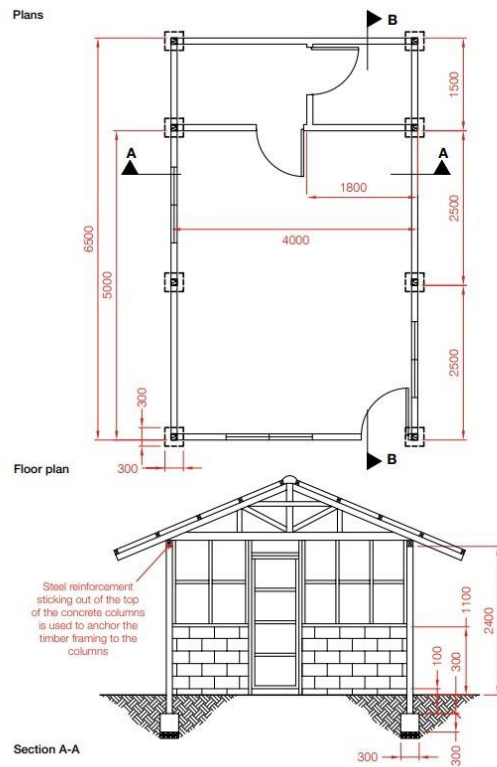

Figure 26: Section and Floor Plan of temporary shelter [28]

The original design was modified by the use of cold-formed steel (CFS) framing and screw piles as a foundation to improve the original design of the temporary shelter. The main comparison analysis was done material for the cost estimate and theoretical time of completion for assembly. [51]

The study found that the application of DFMA methodology using CFS framing, and screw piles resulted in a 30% reduction in material cost and a 50% reduction in theoretical construction time compared to the original IFRC temporary shelter scheme. [51]

DFMA considerations applied to retrieve the desired results included:

(a) Minimization of the number of parts: The number of parts was already trimmed down to the required number of members based on structural requirements. Hence, the number of parts is already optimized. No further reduction of members is necessary as all parts are deemed essential.

(b) Ease of handling: The design was optimized for ease of handling by using lightweight materials such as cold-formed steel (CFS) framing and screw piles. The use of standardized parts also contributed to the ease of handling by reducing the need for skilled labor and simplifying the assembly process.

(c) Ease of insertion of parts: The design was optimized for ease of insertion of parts by using



standardized parts and prefabricated components. The use of CFS framing and screw piles also contributed to the ease of insertion of parts by eliminating the need for heavy equipment and reducing the time required for assembly.

(d) Standardised parts: The use of standardized parts contributed to the reduction of material cost and simplified the assembly process. The use of CFS framing and screw piles also contributed to the use of standardized parts by eliminating the need for custom fabrication and reducing the time required for assembly.

(e) Design for current process capabilities: The design was optimized for current process capabilities by using materials and components that are readily available in the local market. The use of CFS framing and screw piles also contributed to the design for current process capabilities by using materials and components that are easy to transport and handle.

(f) Maintain a margin for alternative design and assembly processes: The design was optimized to maintain a margin for alternative design and assembly processes by using modular components that can be easily replaced or modified. The use of CFS framing and screw piles also contributed to maintaining a margin for alternative design and assembly processes by allowing for easy disassembly and reassembly of the shelter.

## **Adequate Shelter Guidelines**

Even though an ideal solution for the problem depends on many factors, a proposed solution is the use of a kit of parts construction incorporating DFMA for a sustainable approach. In order to establish a design, the Sphere handbook elaborates on the minimum required space for living. Sphere Handbook (2018) defines some of the functions of appropriate shelters when a crisis hits. This figure highlights six functions: protection from the weather, health, support for family and community life, dignity, security, and livelihoods. [78]

In comparison to other handbooks, such as the fourth edition of the UNHCR Emergency

Handbook, primarily a tool for UNHCR emergency operations and its workforce, it is generally agreed that protection from outside elements, a safe place to live, privacy, and security are the primary functions an adequate shelter should provide.

## **Adequate Shelter Provisions**

- The "adequacy of shelter" concept can be applied to all shelters, from emergency to permanent shelters, as shelter is a process, not a product. The key points from the Humanitarian Shelter Guidelines in Figure include: [79]
- Safe from further risk: Safe based on two principles: 1) sufficiently distant from any hazard and 2) shelter design and material selection can resist hazards.
- Environmentally sustainable: Use sustainably sourced materials (e.g., reusable, resaleable, recyclable or biodegradable or local materials) whenever possible.
- Adequately durable: Maintain sufficient structural integrity for its expected period of occupancy.
- Culturally appropriate: Ensure cultural appropriateness of shelter by involving the

affected population through the design and implementation process.

- Climatically suitable: Suit all seasons of the year for a particular climate (hot versus cold) in the case that families and individuals may need to occupy their shelter for a longer period of time.
- Adequate facilities and tools: Provide WASH (Water Sanitation and Hygiene) programs and basic tools, fuel, and equipment to cook.
- Access to services: Access to healthcare services, schools, childcare centers, and other social facilities (unlikely to include or provide all).

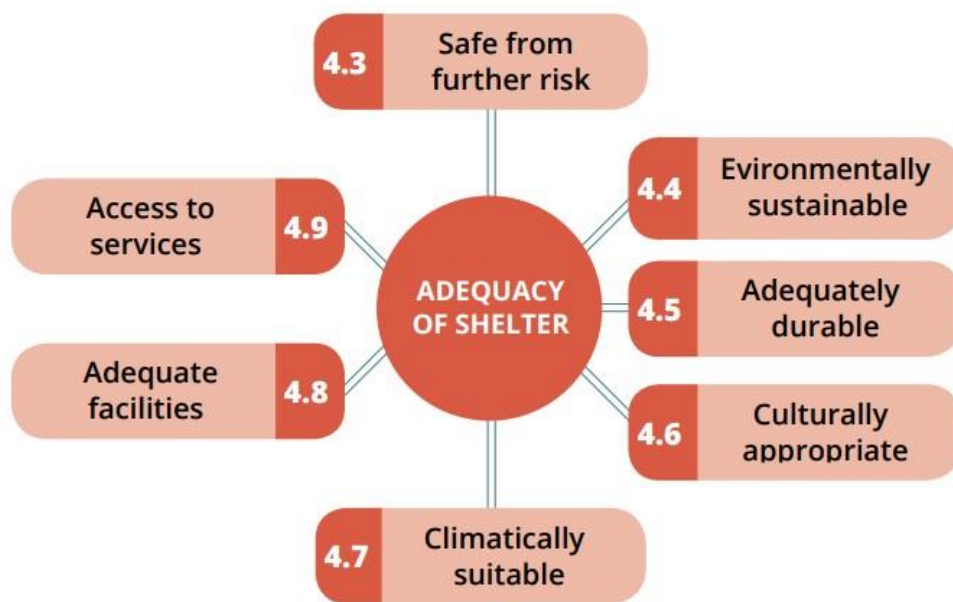

*Figure 27: Adequacy of Shelter [79]*

## Living Space Requirements

There is a minimum standard of living space for shelters as defined by the Sphere Handbook.

The UNHCR Emergency Handbook and the Humanitarian Shelter Guidelines follow similar standards to Sphere, as shown in the table. The minimum space indicated is applicable in the emergency phase and temporary or transitional shelter solutions. All sources have the exact minimum requirements for the size and height of shelters.

Parameters	Sphere	Unher	Humanitarian
<b>Living space</b>	<p>Minimum <b>3.5 sqm</b> of living space per person, excludes cooking space and sanitation facilities.</p> <p><b>4.5 sqm</b> of living space per person in cold climates where internal cooking space and sanitation facilities are included.</p>	<p><b>3.5 sqm</b> in tropical or warm climates (Assumes cooking will take place outside).</p> <p><b>4.5-5.5 sqm</b> in cold climates.</p>	Minimum 3.5 sqm.
<b>Height</b>	<p>Internal floor-to-ceiling height of at least <b>2m</b> at the highest point.</p> <p><b>2.6m</b> for hot climates.</p>	<p>Minimum height of <b>2m</b> at the highest point.</p> <p>Max <b>2m</b> ceiling for cold climates (to reduce heat space).</p>	Minimum <b>2.4m</b> .

*Table 5: Living Space Guidelines  
Source: [79]*

### Cultural sensitivity:

Temporary shelters often don't consider local customs and preferences, as they're designed without adequate input from affected communities, leading to culturally inappropriate solutions.

### Cost Efficiency:

Shelter production in foreign countries, along with transportation expenses, raises the overall cost of shelters, causing delays in delivery to disaster-stricken areas.

### **Environmental Impact:**

Many temporary shelters go to waste when no longer needed, resulting in resource and material wastage, along with the environmental pollution of the sites where they were placed.

Therefore, the solution must be built using local or available materials in the region and by the community. It is serving instead of producing from machinery or skilled labor. By doing so, the community is involved in the process, the cost will be reduced significantly, and the shelter parts can be reused for another disaster in the future or for other purposes.

### **“Kit of Parts” Modular Design**

Each kit-of-part contains a set of materials for a specific function of space (e.g., sleeping, cooking/dining, working, playing, etc), providing a proper home.

This type of home starts with a base module with one living space - the sleeping space - but can expand and create a multi-functioning system. This allows for more flexibility in design options. Due to the kit-of-parts, the home can meet the different needs of each disaster victim and family and make them feel comfortable, safe, and secure in their personalized shelter.

This system also incorporates flexibility in the use of different materials depending on the climatic conditions of the region by changing the kit as required.

One example of such a solution was implemented recently in a study conducted for post-disaster solutions in Hawaii. [80]

### **Proposed Temporary Home for Hawaii Disaster (Case 1)**

This temporary housing uses modules to address the varying requirements of different user groups that need to be housed. The modules can be assembled with ease. They can be erected on-site with unskilled labor using simple hand tools and no additional machinery. The base and extra modules follow the Sphere Handbook criteria for living spaces, which require a minimum of 3 to 3.5 meters of living space per person.

#### **Base Module**

For every temporary shelter, there is a base module. This base module consists of a sleeping space with 64 square footage (8' x 8'), which fits about two people. It is designed with a structural framework made of lumber elevated one foot from the ground due to the concrete pier blocks. The plywood wall panels are designed to attach directly to the lumber framing with screws and braces to enable quick and hassle-free construction. The wall panels also facilitate the flexibility to place doors and windows on any side of the shelter, thereby creating the possibility of modifying the layouts based on specific site conditions. The corrugated metal sheets are bolted on top of the roof framing.

The assembly of the base module starts at the base with the concrete pier block foundation, where the vertical supports attach to the steel plate. Then, the floor framing made up of horizontal wood studs is installed, and plywood sheets are placed on top. The next set focuses on the walls and roof support members that stabilize the structure. Then, the last step is to set up the walls and attach the roof to complete the base module. This base module is relatively affordable as it costs around €4500.

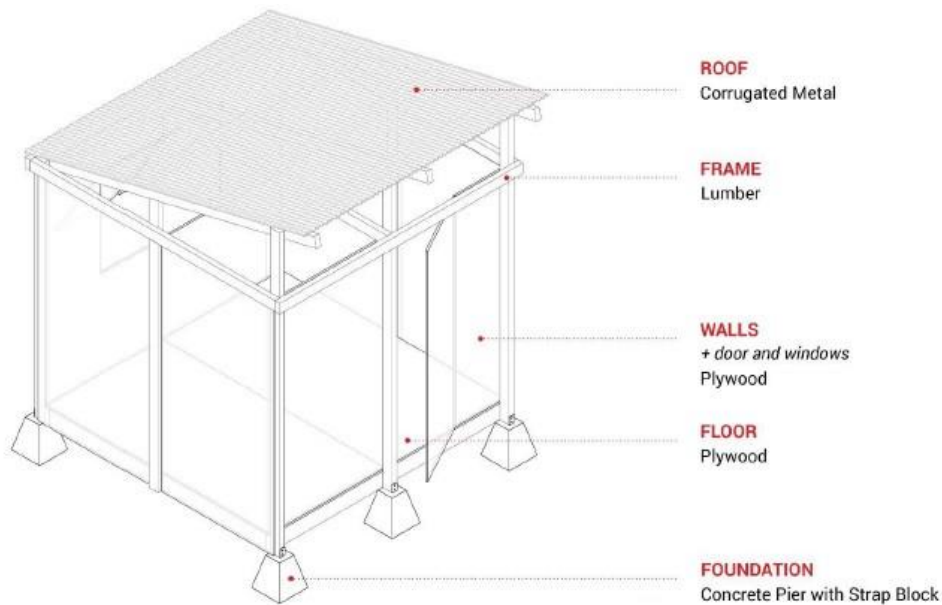

*Figure 28: 3D- Scheme of the Base Module  
[80]*

### **Flexible Configurations**

The design concept revolves around five predefined modules that can be flexibly combined to create a wide array of configurations tailored to varying occupant needs and physical conditions.

These modules, as shown in the figure, encompass a sleeping space, accommodating additional occupants with ease, a fully equipped kitchen complete with a pegboard wall system for storage and a sink, a well-appointed bathroom with essential wash facilities, a dedicated workspace featuring foldable desk and ample storage solutions, and an open area with floor storage, offering versatility in expanding module size or serving as an open corridor.

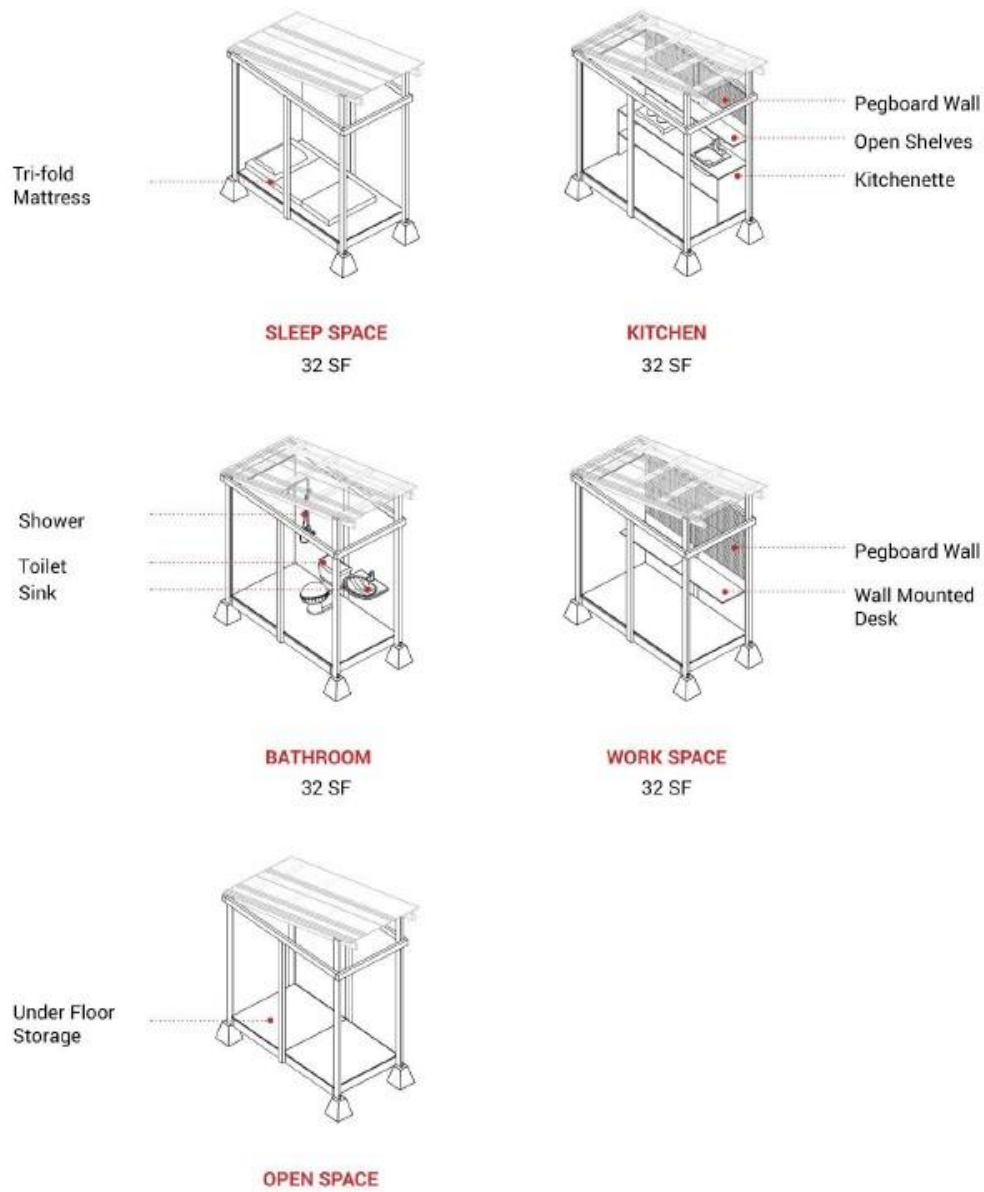

Figure 29: Module Options  
[80]

This modular approach ensures adaptability and functionality in optimizing the use of space for different contexts and requirements, making it a versatile solution for various living scenarios. Different configurations can be applied depending on the no. of users and their usage, as shown in the figure.

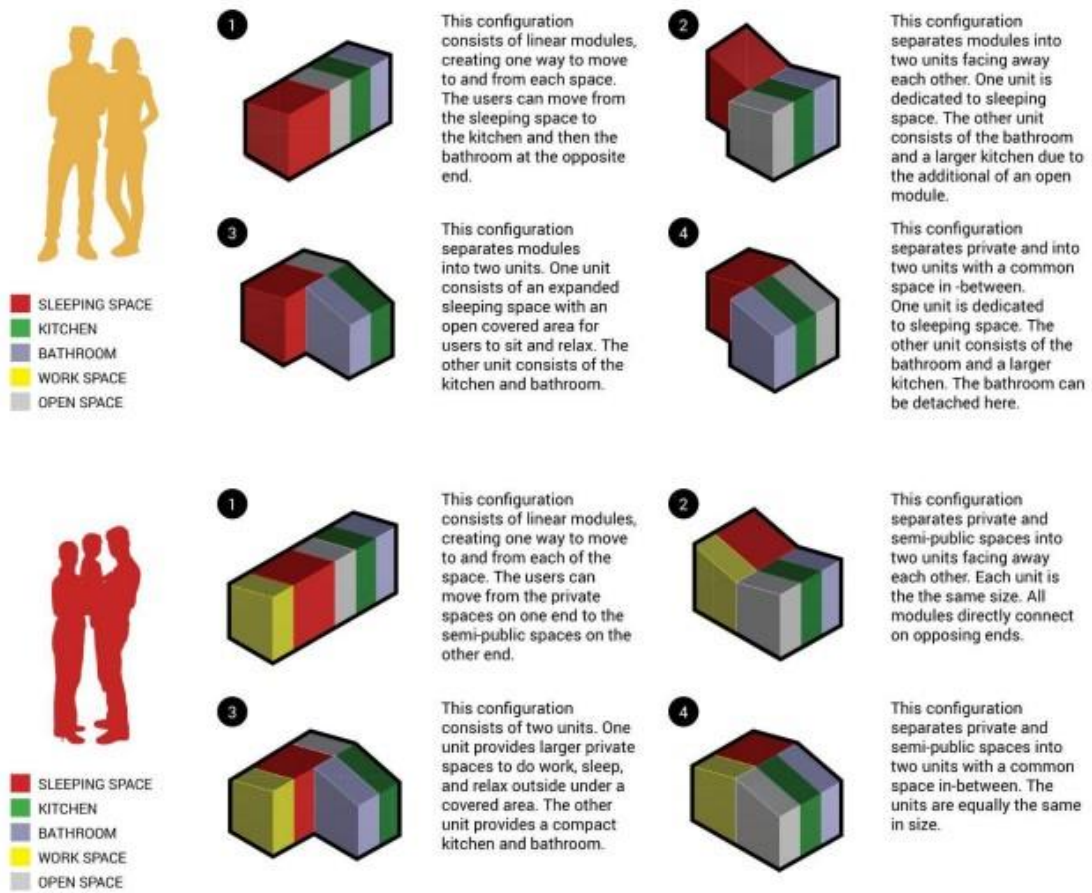

Figure 30: Flexible Configurations [80]

### Sustainable and Innovative Technologies

The solution proposed can also potentially incorporate sustainable technologies such as rainwater catchment for water storage for washing, irrigation, etc., and solar panels to power up temporary homes for basic utilities.

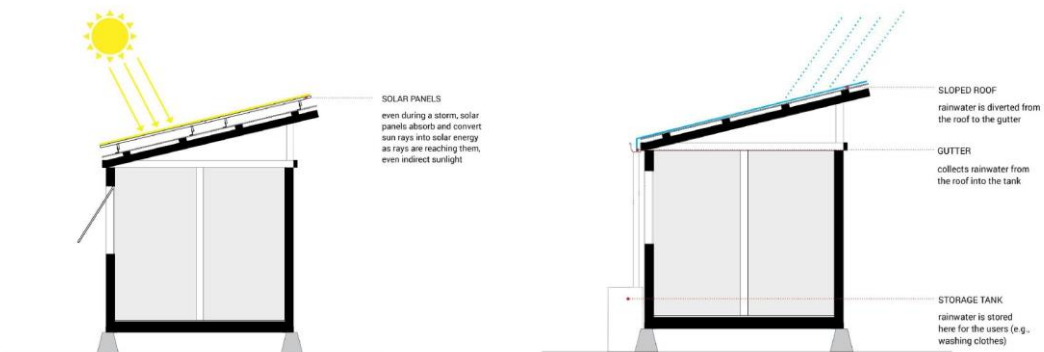

Figure 31: Illustration of Solar Panels and RainWater Catchment [80]



## UBUILD Construction System (Case 2)

One other case study was conducted using the UBUILD module system, in which whole pieces are made using a numerical control machine. The system creates the joints with direct splices without using hardware. It requires a screwdriver as the only tool and can be mounted by two people in one day, as the building is assembled by fitting the pieces and screwing them together, although the optimum number of people would be four. It does not require auxiliary equipment for assembly, although it must be transported by truck, and it is advisable that the truck has a small crane to unload the packages in which the module is transported. [81]

While designing this module, several construction factors were considered:

- **Depth and Narrow Frontage:** It is advisable to construct the house with greater depth and a narrower frontage. This design allows for the development of clusters with less demanding access roads and shorter service networks for water, electricity, and sewage.
- **Terraced Houses:** Incorporating terraced houses along the longer side of the structure can improve thermal conditions and lead to significant energy savings.
- **Multi-Storey Clusters:** Consider two- or three-story clusters instead of single-floor housing modules. To provide access to upper floors, consider using an external gallery with staircases placed at intervals. Ground-floor homes also ensure accessibility for individuals with reduced mobility.
- **Staircase:** Staircases serve two important functions. They enable clusters of modules to adapt to sloping terrain without extensive ground conditioning work, and they allow for adjustments in alignments without the need to modify prefabricated modules, which can be complex and costly.
- **Modular Design:** Design the dwellings in a way that they can be replaced with permanent conventional dwellings when needed. Prefabricated modules can be reused, and installation networks can support new housing without requiring major layout changes.
- **Local Manufacturing:** Address criticisms of poor geographical adaptability by proposing a scalable manufacturing system. This system utilizes models fully parameterized in BIM, which can be easily sent via email and interpreted by numerical control manufacturing machines. Many carpentry workshops now have these systems, enabling local and immediate construction and reducing issues related to scarcity, delays, and transportation.

There are two types of modules analyzed in this research:

- **Type 1:** Designed for groups of four individuals of the same sex with no family ties. These modules include a bathroom with three partitions for simultaneous use, a combined living bedroom space, and a kitchen. They measure 3.00 x 6.00 meters and are grouped in pairs to share bathrooms, minimizing facilities.

- **Type 2:** Designed for families of up to six people. These modules measure 2.50 x 7.50 meters and are arranged perpendicularly to the gallery. They consist of a front area with a kitchen and living space, with beds that fold up for daytime use. In the rear area, there is a bedroom with up to four bunk beds and an intermediate area with a partitioned bathroom.



*Figure 32: Plan of Ubuild Temporary Home [81]*

In both cases, access to the upper floor is provided via staircases leading to a gallery that connects to the houses. Both versions are designed for modular construction, with lightweight elements that can be assembled by affected individuals themselves using basic tools and equipment such as a screwdriver.

The proposed solution is based on the design of a 2.50 x 6.00 m type 2 wooden experimental module with a capacity of 4 to 6 people. It has all the essential elements for the daily activities of a family or a group of people. It consists of a fixed bedroom, a bathroom with a toilet, wash basin, and shower, a kitchen area, and a living area, which can be transformed into a bedroom. The module has passive conditioning systems and adequate insulation.

The construction approach was to use a light frame structure divided into standardized, precisely machined parts, simplifying assembly with minimal equipment.

The following figure illustrates the general scheme of the module.



*Figure 33: General Scheme of the Base Module  
[81]*

The system starts with 120x240mm beams accommodating 100x200mm floor struts. These beams feature adaptable tongue-and-groove ends. Facade uprights and system beams connect to the top notches.

Uprights are placed at 550mm intervals, and the floor structure is replicated on the ceiling, allowing stacking. The roof can be wooden or alternative.

All wooden components are GL-24h glued laminated spruce wood, treated for outdoor use class 3, complying with Spanish CTE-SE-M standards.

Outer walls are assembled with panels, insulation, doors, and windows based on modularity. Doors and windows arrive pre-assembled. Buildings are raised on adjustable metal supports with minimal foundation requirements.

The foundation can involve concrete-filled tires or earth anchors. A beam lattice on supports, adjustable for leveling, prepares for component installation with a few screws.

Once the frame is done, floor, enclosure, and ceiling panels are installed, designed for manageable weight and including insulation. The coverings include a ventilated facade and a roof awning, sloping outward for rain or inward for water collection in dry areas.

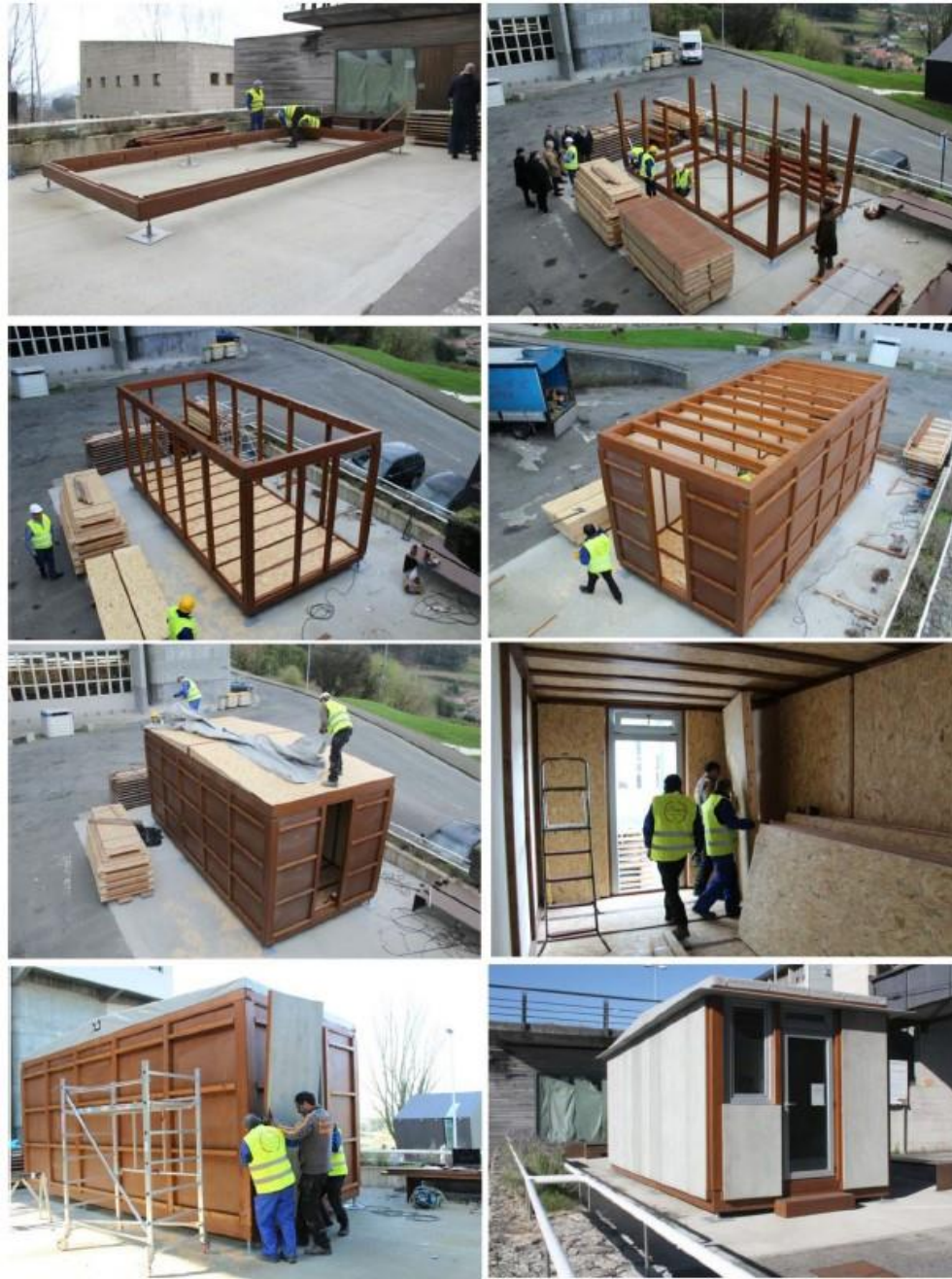

*Figure 34: Construction Scheme of the Ubuild Temporary Home  
[81]*

The prototype is designed to provide not just basic accommodation but also technical and human dignity. Grouping these prototypes aims to maintain social connections and a reasonable quality of life for those affected.



*Figure 35: Double Story Layout of Temporary Homes  
[81]*

The proposals align with Sphere Project standards, with the built module meeting Sphere's minimum standards due to budget constraints.

The prototype is not only architecturally and economically viable but also suitable for storage and transport. It can be quickly adopted by woodworking shops equipped with numerical control machinery worldwide. However, if such technology is unavailable, production in industries with these resources and transportation to the final site may be considered with cost-effectiveness analysis.

This prototype is designed for oceanic or Mediterranean climates and can be easily adapted for hot climates.

In order to propose a solution integrating DFMA principles, a comparative assessment is done between the discussed modular approaches.



<b>COMPARITIVE ASSESSMENT</b>					
<b>Parameters</b>	Katrina Cottages (America)	G.P Containers (Japan)	Case Study (Philippines)	Case Study (Hawaii Modular Case Study)	Case Study (UBUILD)
<b>Adequate Shelter Provision (SPHERE)</b>	✓	✓	✓	✓	✓
<b>No. of people per house</b>	4	Upto 6	4-6	2-3	2
<b>Construction Time</b>	2-3 Days	98 Days	6 Days	1-2 Days	1 Day
<b>Life span of building</b>	1.5 years	20-25 years	5 years	1.5 years	>20 years
<b>Sustainable Material Usage</b>	✓	✓	✓	✓	✓

*Table 6: Comparative Assessment  
(Source: Author's Own Compliation)*

## **Proposed Solution**

The case studies have incorporated DFMA principles to some extent, along with innovative techniques such as "kit of parts" modular construction. Every solution depends on a number of parameters, from geographical location, country's financial circumstances, culture, availability of technologies, etc.

In a catastrophe, two of the important factors are the construction time and a dignified living standard. A viable solution is proposed in the table below, factoring in the desired construction time, labor requirements, and minimal use of tools for the construction.



<b>PROPOSED SOLUTION</b>	
<b>Type of Construction</b>	Modular (Kit of Parts) with DFMA Incorporation
<b>Construction Time</b>	2-3 Days
<b>Labor Required for Assembly</b>	Little to no experience
<b>Foundation</b>	Ground Screws
<b>Envelope</b>	Structural Insulated Panels (Steel)
<b>Doors and Windows</b>	Pre Assembled
<b>Tools for Connections</b>	Basic Tools

*Table 7: Proposed Solution  
(Source: Author's Own Compilation)*

### **Design Parameters**

When designing a house in post-disaster situations, it is important to factor in geographical, economic, and sustainability aspects.

- **Narrow Design:** It is convenient that the house is built in depth, with a narrow front. This allows for clusters with less developed access roads and shorter service networks such as water, electricity, and sewerage.
- **Scalability and Modularity:** Ensure that the design is based on a modular system that allows for easy expansion by adding additional modules. This can adapt to changing family sizes or housing needs.
- **Structural Integrity:** Design the modules with strong foundations and structural systems that can meet the local building codes and withstand future disasters when expanded.
- **Material Selection:** Choose durable, sustainable, and easily recyclable materials to ensure longevity and reduce maintenance and replacement costs.
- **Energy Efficiency:** Incorporate energy-efficient features to reduce long-term operating costs and environmental impacts, such as insulation, green water, and energy use.
- **Infrastructure Integration:** Plan for the integration of utilities, such as plumbing,

electrical, and HVAC, in a way that can be easily expanded as more modules are added.

- **Accessibility and Inclusivity:** Ensure that the design is accessible and inclusive, accommodating individuals with disabilities or special needs.
- **Community Spaces:** Consider common areas and communal spaces within the modular design to foster a sense of community among residents.
- **Local Climate and Environment:** Adapt the design to the specific climate and environmental conditions of the region, including factors like extreme temperatures, humidity, and seismic activity.
- **Safety Requirements:** Incorporate safety features, such as fire and pest-resistant materials, to ensure the well-being of residents.
- **Ease of Assembly:** Ensure that the assembly of modules is straightforward, potentially with minimal reliance on specialized labor, to facilitate rapid deployment.
- **Long-Term Maintenance:** Plan for long-term maintenance and regular inspections to keep the housing in good condition and extend its lifespan.
- **Community Involvement:** Engage with the affected community during the design process to incorporate their feedback and ensure that the housing meets their needs. Provide clear assembly instructions and training for residents or local construction teams to ensure safe and effective construction.
- **Regulatory Compliance:** Ensure that the design complies with local building codes and regulations for both temporary and permanent housing.

## **Foundation**

The foundation for the proposed solution is the use of ground screws, also known as earth screws. They are long screws with a helix design that are used to secure structures into the ground without the need for concrete or digging. They are made from steel, and hot dipped galvanized, resulting in a really strong, hardwearing foundation.

Ground screws offer several key advantages:

1. **Easy Installation:** Ground screws are quick to install, even in challenging soil types, requiring minimal equipment. They're ideal for remote or inaccessible areas. [98] [99]
2. **Cost-Effective:** Ground screws are a budget-friendly option. They demand fewer materials, labor, and equipment compared to traditional foundations. [98] [99]
3. **Eco-Friendly:** Ground screws are environmentally conscious. They eliminate the need for concrete, a major greenhouse gas emitter, and leave a smaller carbon footprint with minimal disruption to the environment. [98] [99]
4. **Durable:** Ground screws are exceptionally sturdy and low-maintenance, capable of lasting for decades in various weather conditions. [98] [99]
5. **Easy Inspection:** Ground screws are easily inspected and maintained without disturbing the

foundation structure. [98] [99]



*Figure 36: Ground Screws  
[98]*



*Figure 37: Ground Screws Foundation Illustration  
[99]*

## Installation





<p>Step 1:</p> 	<p>Pre-installation of your ground screw by drilling a pilot hole using a drill to break up any roots or stones that can interfere with the ground screw. The pilot hole should be no deeper than the depth the ground screw is installed to.</p>
<p>Step 2:</p> 	<p>If the ground is hard and dry, fill your pilot hole with water to soften the ground.</p> <p>Position your ground screw and begin rotating the ground screw whilst applying downward pressure until the thread bites.</p> <p>This should only be a few turns, at which point you can use the installation tool for the rest of the process.</p>
<p>Step 3:</p> 	<p>Place the ground screw installation tool over the top of the ground screw, slotting the metal bar into the U-shaped cut-out. Rotate the handle of the tool whilst keeping it centered, checking the level of the ground screw as you go.</p>
<p>Step 4:</p> 	<p>If installation becomes difficult, please use 2 persons to rotate the bar. DO NOT pull the bar to one end to gain leverage, as this may result in injury or damage to the tool.</p> <p>Leave at least a 40mm air gap between the top of the ground screw and ground level. This ensures airflow to the structure and reduces the exposure of the timber to moisture.</p>
<p>Step 5:</p> 	<p>Fix SIPs bracket to the ground screw using steel self-drilling screws.</p> <p>Once your ground screws are installed, they are immediately ready to build on.</p>

Table 8 : Ground Screw Installation Steps  
[100]

<b>GROUND SCREW DETAIL</b>	
<b>Base Module Dimensions</b>	30' x 14' (420 sqft)
<b>Screw Length and Bracket</b>	750 mm with SIP bracket Minimum: 25mm to Maximum: 300mm above ground level.
<b>No. Of Ground Screws Required</b>	45 (9 rows of 5)
<b>Approx Cost (Base Module)</b>	~1200-1300 Euros.

*Table 9: Ground Screws Detail  
(Source: Authors Own Compilation , [108])*

## **Envelope**

For the Envelope, the goal is to use sustainable materials that are also time and energy-efficient. Structural insulated panels (SIPs), specifically snap and lock steel SIPs, are proposed.

### **Structural Insulated Panels (SIPs)**

The concept of structural insulated panels (SIPs) was first introduced at the Forest Product Laboratory in Madison, Wisconsin, in 1935. Researchers there found that hardboard sheathing and plywood could bear structural loads like walls. Over the next 30 years, research continued to refine SIP design and materials, leading to the first commercial SIP produced by Dow in 1952. Rigid foam insulation became widely available in the 1960s, coinciding with the affordability of SIPs. In 1990, the Structural Insulation Panel Association (SIPA) was established as a trade organization. Recently, there has been a growing interest in SIPs among researchers, with a focus on SIPs featuring an inner core and two outer laminate layers due to their high strength-to-weight ratio, precise insulation values, and cost-effectiveness. [102]

The most common configuration is the use of expanded polystyrene foam (insulation) with exterior skin composed of Oriented Strand Board or Steel (aluminum, galvanized steel). [103]

The core of rigid expanded polystyrene foam provides shear strength, while the exterior skins provide tensile and compressive strength. Using a Snap and Lock SIP system for the entire envelope, it can use all its capacity to support vertical loads, has greater racking resistance, and can resist local loads, buckling, and bending. These are important characteristics for resisting earthquake and hurricane forces, making it a perfect time-efficient solution for a post-disaster situation prone to future natural disasters.

Snap and Lock Steel SIPs provide many advantages in comparison to traditional timber frame construction and OSB SIPs.

<b>Parameters</b>	<b>Snap-N-Lock Steel Panels</b>	<b>OSB SIPs</b>	<b>Traditional Stick Timber Frame</b>
<b>Strength</b>	2-3 times stronger than stick-built	2-3 times stronger than stick-built	Baseline
<b>Insulation</b>	High R-values, 25% more efficient	High R-values, 25% more efficient	Baseline
<b>Airtightness</b>	Maintains airtight envelope	Maintains airtight envelope	May develop gaps over time
<b>VOC Emissions</b>	No VOC emissions	Potential emissions from materials	Potential emissions from materials
<b>Seismic and Wind Resistance</b>	High seismic and wind resistance	High seismic and wind resistance	Less resistant to natural forces
<b>Moisture Barrier</b>	Not required	Requires an additional moisture barrier	Typically required
<b>Strength-to-Weight Ratio</b>	Tremendous, lightweight installation	Heavier, often necessitating heavy equipment	Requires heavy timber framing
<b>Pest Resistance</b>	Essentially unaffected by pests	Vulnerable to pests, unless treated	Vulnerable to pests
<b>Joint Connection</b>	Interlocks without additional framing member	Requires plywood spline at each joint	Requires traditional framing
<b>Fire Resistance</b>	Highly fire-resistant	Requires additional fire resistant layer	Fire resistance varies



<b>Environmental Impact</b>	Components are recyclable, minimal waste on-site	Components are recyclable, minimal waste on-site	More waste generation
<b>Installation Time</b>	Upto 50% faster installation.	Upto 50% faster installation.	Baseline
<b>Energy Efficiency</b>	40-60% more energy efficient	40-60% more energy efficient	Baseline
<b>Labor Cost</b>	Upto 55% less than traditional construction	Upto 55% less than traditional construction	Standard construction labor
<b>Material Cost</b>	~5% more than traditional construction	~5% more than traditional construction	Baseline

*Table 10; Analysis of Snap-N-Lock Panels to Traditional Timber Frames and OSB SIPs  
(Source: Author's Own Compilation) [101] [102][103][107]*

The panels can be used for flooring, walls, and roofs, making it ideal for fast, efficient construction of the envelope. The doors and windows are delivered to the site and prefabricated to be installed on-site.

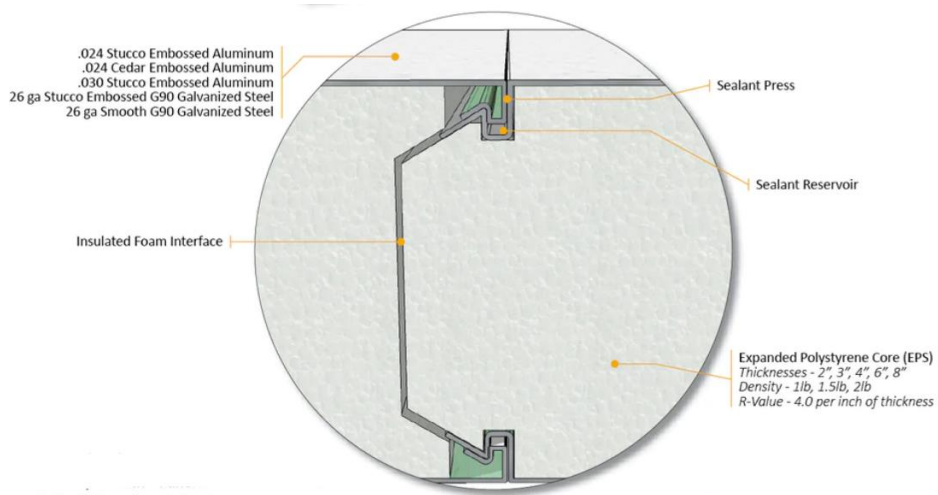

Figure 38: Steel SIP & Snap and Lock Detail  
 [109]

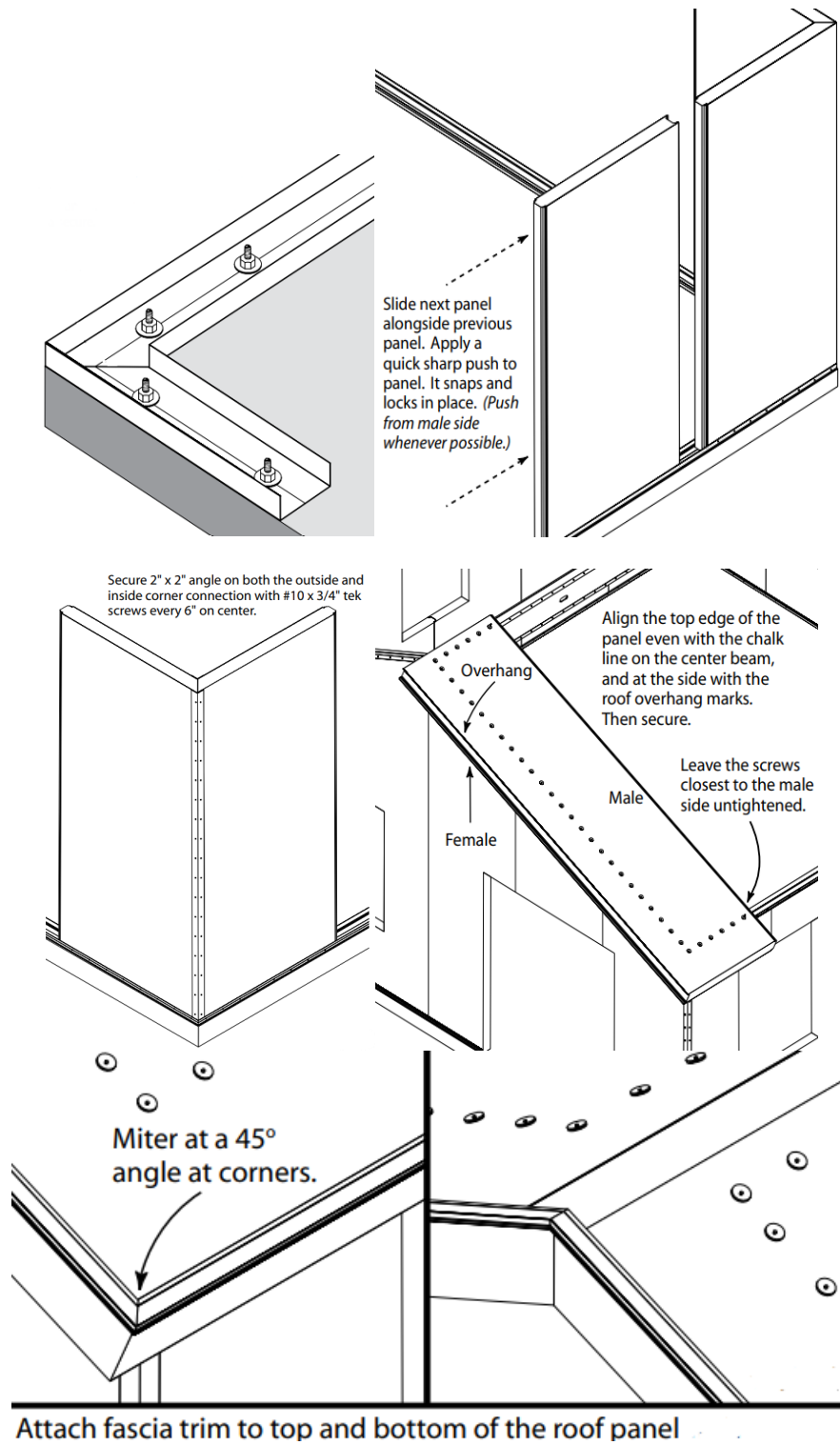

Figure 39: Snap-N-Lock Installation Detail  
[109]

<b>STEEL SIPS DETAIL</b>	
<b>Walls</b>	Height: 8' , 10' / Width: 48" / Thickness: 6"
<b>Roof</b>	Slope 3:12 / Length: 15' / Width 48" / Thickness: 8"
<b>Floor</b>	Length 14' / Width 48" / Thickness 8"
<b>Approx Cost (Base Module)</b>	~10000-15000 Euros. [104] [105][106]

*Table 11: Steel SIPS Detail  
(Source: Author's Own Compilation)*

### **Connection Tools**

As stated in the DFMA considerations and cases explained before, the recommended method would be to use basic connection tools along with minimal assembly steps. The use of Snap and lock SIPS minimizes the use of screws, helping build a house using basic tools such as adhesives, screws, and a screwdriver.

### **Prototype**

The proposed prototype offers a base module with all the necessary amenities required for a family of 2-3 people with an area of 420 sqft. With an open kitchen, washroom, living/bed space, and an optional deck, this type of base module abides by the SPHERE guidelines. The extension can be added with one or two extra rooms, which can be used accordingly to increase the accommodation for families with up to 6 people.

Different designs and extensions can be added according to the requirements of the affectees in order to have a dignified and comfortable living standard. The provision of 2 stories can also be incorporated where space allocation might be a hurdle, as SIPS act as load-bearing walls. Moreover, Steel SIPS provide longer spans as compared to OSB panels.

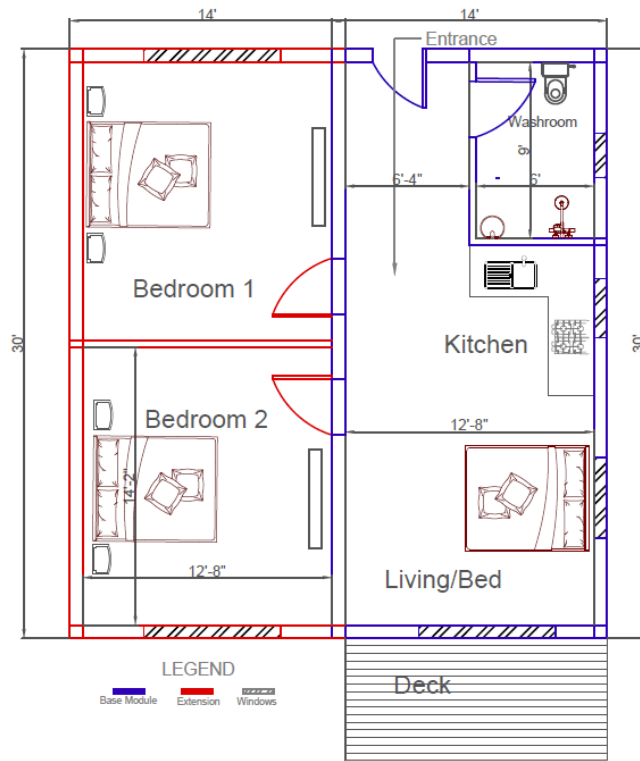

Figure 40 : Prototype Floor Plan



Figure 41: Prototype Base Module & Extension Plan



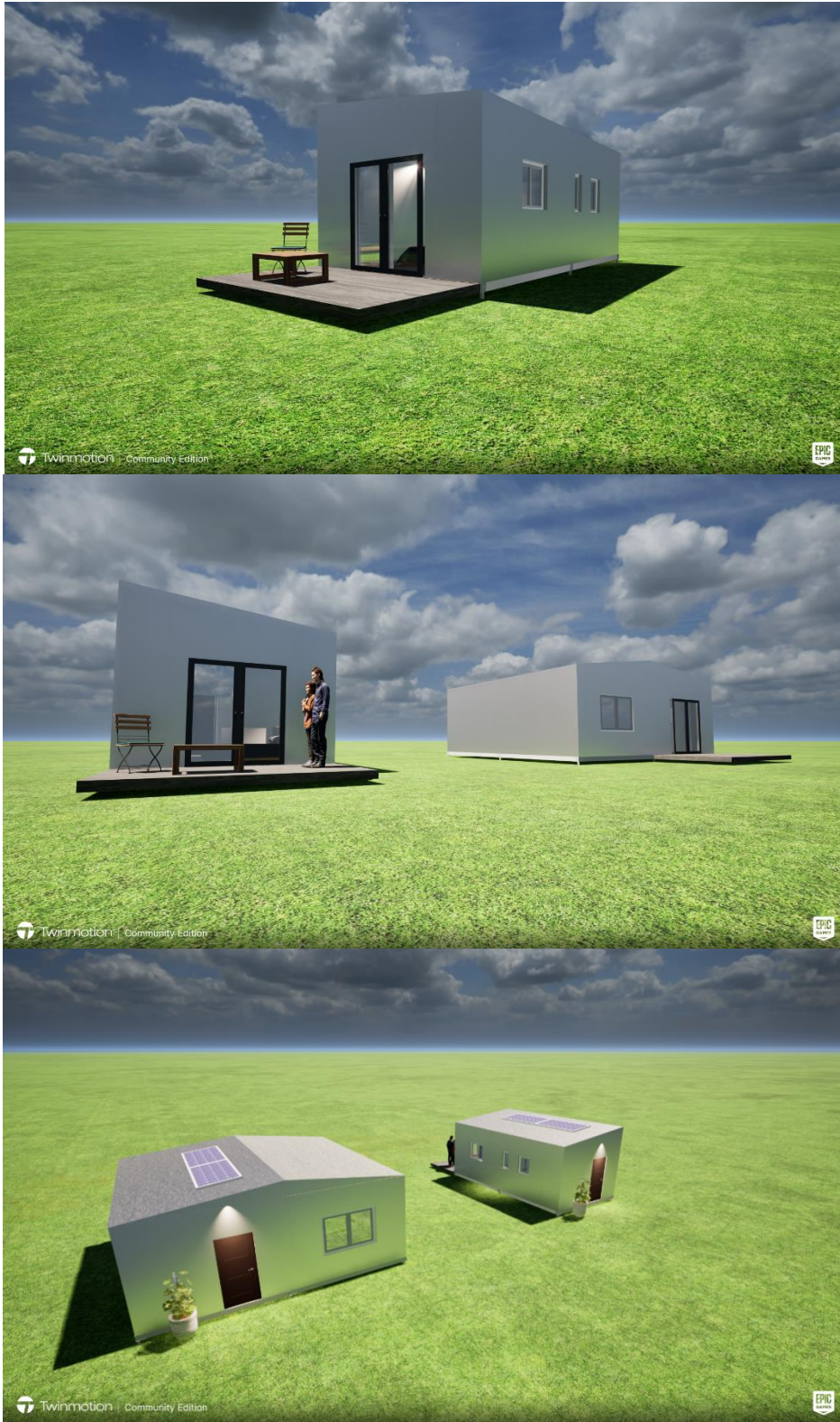

Figure 42: Prototype 3D - Illustrations



## **DFMA Principles Incorporation**

Incorporating ground anchors as a foundation, Steel Snap and Lock SIP panels for the envelope, and pre-fabricated doors and windows into a construction project can effectively align with various Design for Manufacture and Assembly (DFMA) principles:

### **Minimization of the number of parts**

- Ground anchors for the foundation can replace the need for traditional concrete or masonry blocks, significantly reducing the number of foundation components.
- Steel Snap and Lock SIP panels serve as a multifunctional solution that minimizes the number of separate parts required for framing, insulation, and sheathing in a building envelope.
- Pre-fabricated doors and windows come as complete units, further reducing the number of parts needed for installation. This integrated approach significantly minimizes the overall number of components in the construction process.

### **Ease of handling**

- Ground anchors are lightweight and easy to transport and handle, reducing the need for heavy machinery and specialized labor during installation.
- Steel Snap and Lock SIP panels are designed for easy handling, with their snap-together connections simplifying assembly.
- Pre-fabricated doors and windows come ready for installation, making the handling of these components straightforward and efficient.

### **Ease of insertion of parts**

- Ground anchors are designed for easy insertion into the ground, replacing traditional concrete work.
- Steel Snap and Lock SIP panels are precision-manufactured to snap fit together seamlessly, simplifying their insertion into the building's structure.
- Pre-fabricated doors and windows are designed to fit precisely within standard openings, ensuring ease of insertion.

### **Standardized parts**

- Ground anchors come in standardized sizes and configurations, making selection and procurement straightforward and ensuring compatibility with common construction practices.
- Steel Snap and Lock SIP panels are manufactured to standardized specifications, reducing the need for custom fabrication and ensuring consistency in the building envelope.
- Pre-fabricated doors and windows are available in common sizes and configurations, simplifying the selection and purchase process.

### **Design for current process capabilities**

- Ground anchors are adaptable to different soil conditions, aligning with regional process capabilities in construction.
- SIP panels are in line with the current process capabilities of the manufacturing industry and are accessible in most countries.
- Pre-fabricated doors and windows are designed to work with common framing and opening sizes, ensuring compatibility with current construction practices.

### **Maintain a margin for alternative design and assembly processes**

- Ground anchors offer flexibility in foundation design and can be repositioned or replaced as needed, providing a margin for alternative approaches.
- Steel Snap and Lock SIP panels are modular, allowing for easy adjustments or modifications to the building envelope's design or assembly.
- Pre-fabricated doors and windows can be easily swapped out or modified to accommodate changes in design or assembly processes.

Incorporating a kit of parts modular design with ground anchors, Steel Snap and Lock SIP panels, and pre-fabricated doors and windows into a construction project collectively enhances the efficiency of construction, minimizes the number of parts, eases handling and insertion, utilizes standardized components, aligns with current process capabilities, and provides flexibility for alternative design and assembly processes making it viable for post-disaster housing solution where time and efficiency is of the utmost importance.

### **Sustainable Construction & Innovative Technologies**

The materials proposed are eco-friendly, with minimal waste on site. Steel SIPs are recyclable and have a long-life span with their energy-efficient features, making them one of the best quick, cost-effective, and sustainable solutions.

Innovative technologies such as green water and energy usage can be implemented as Collecting and storing rainwater from roofs for domestic use, and other similar situations can be beneficial, especially when there is a water shortage and it may not be available after a natural disaster, by attaching a water catchment system that uses a gutter, piping, and water storage tank to collect water for basic use.

Similarly, most natural disasters knock out power lines and disrupt the energy supply. A fast and eco-friendly solution to this problem is utilizing solar energy by providing solar panels brought from off-site and operated independently. Solar panels are resilient during the event of a natural disaster and can be set up on the spot to provide large amounts of power for a period of time. By incorporating photovoltaic solar panels on the roof, homes can provide their own self-sustaining energy source, operating their own heating and electrical output.

## Conclusion

In conclusion, this study delved into the transformative potential of Design for Manufacture and Assembly (DFMA) in housing solutions, particularly highlighting its capacity to enable the creation of adaptable structures capable of serving multiple disaster scenarios while holding the potential to merge into permanent housing solutions.

The case studies explored within this research have not only demonstrated the immediate benefits of DFMA in streamlining construction processes, reducing costs, and minimizing waste but have also illuminated its role in fostering long-term resilience and adaptability. One of the remarkable facts revealed by these case studies is how DFMA can empower the design of temporary-permanent homes that can serve as versatile assets in disaster-prone regions.

The use of Steel SIPs in building homes makes them modular and easily reconfigurable, allowing them to adapt to various disaster scenarios, from earthquakes to floods to hurricanes, thanks to their structural capability along with ease of assembly.

Furthermore, DFMA enables the construction of temporary homes with built-in flexibility, facilitating future expansion or modification to transition these structures into permanent housing solutions. This adapt-and-evolve approach is a sustainable solution for communities facing recurrent disasters or prolonged periods of uncertainty, as it ensures that investment in such post-disaster housing can yield long-term benefits.

Moreover, the user-centric design principles incorporated within the DFMA framework ensure that these adaptable structures maintain a focus on the well-being, safety, and dignity of their occupants throughout their lifecycle, whether in temporary or permanent roles.

In summary, this research underscores how DFMA can revolutionize the way we approach housing crisis in a post-disaster situation, not only by enhancing its efficiency, sustainability, and liveability but also by equipping these structures with the adaptability to serve in disaster scenarios and enabling a smooth transition into permanent housing solutions.

## References

1. Gao, S., Jin, R., & Lu, W. (2020). Design for manufacture and assembly in construction: a review. *Building research & information*, 48(5), 538-550.
2. Bogue, R., (2012), Design for manufacture and assembly: background, capabilities and applications. *Assembly Automation*, 32(2), 112-118.
3. Gao, S., Low, S.P. and Nair, K., (2018). Design for manufacturing and assembly (DFMA): a preliminary study of factors influencing its adoption in Singapore. *Architectural engineering and design management*, 14(6), 440-456.
4. Emmatty, F. J., & Sarmah, S. P. (2012). Modular product development through platform-based design and DFMA. *Journal of Engineering Design*, 23(9), 696-714.
5. Stoll, H. W. (1986). Design for manufacture: an overview.
6. Bridgewater, C. (1993). Principles of design for automation applied to construction tasks. *Automation in construction*, 2(1), 57-64.
7. Ashley, S. (1995). Cutting costs and time with DFMA. *Mechanical Engineering*, 117(3), 74-77.
8. O'Driscoll, M. (2002). Design for manufacture. *Journal of Materials Processing Technology*, 122(2-3), 318-321.
9. Shanga, G., Ruoyub, J., & Luc, W. Design for Manufacturing and Assembly: Perspectives in Construction.
10. Anumba, C. J., & Evbuomwan, N. F. (1997). Concurrent engineering in design-build projects. *Construction Management & Economics*, 15(3), 271-281.
11. Dave, B., & Koskela, L. (2009). Collaborative knowledge management—a construction case study. *Automation in construction*, 18(7), 894-902.
12. Lu, W., Tan, T., Xu, J., Wang, J., Chen, K., Gao, S., & Xue, F. (2021). Design for manufacture and assembly (DFMA) in construction: The old and the new. *Architectural Engineering and Design Management*, 17(1-2), 77-91.
13. Trivedi A., Singh A. (2017). Prioritizing emergency shelter areas using hybrid multi-criteria decision approach : A case study. *Journal of Multi-Criteria Decision Analyses*, 24, 133–45.
14. Vecere A., Monteiro R., Ammann W.J., Giovinazzi S., Melo R.H. (2017). Risk Reduction Predictive models for post disaster shelter needs assessment. *International Journal of Disaster Risk Reduction*. 21, 44–62.
15. Kim J., Lee J., Ahn B., Shin H., Yoo S., Jang C., et al. (2015). Indoor Thermal Environment of Temporary Mobile Energy Shelter Houses (MeSHs) in South Korea. *Energies*. 8, 11139–52.

16. Forcael, E., González, V., Orozco, F., Vargas, S., Pantoja, A., & Moscoso, P. (2014). Ant colony optimization model for tsunamis evacuation routes. *Computer-Aided Civil and Infrastructure Engineering*, 29(10), 723-737.
17. US Census Bureau. (2011). "Census bureau releases first detailed data on Katrina damage to New Orleans area housing."
18. EM-DAT, Death toll trend. <https://www.emdat.be/>.
19. Cerè, G., Rezgui, Y., & Zhao, W. (2017). Critical review of existing built environment resilience frameworks: directions for future research. *International journal of disaster risk reduction*, 25, 173-189.
20. Ghannad, P. and Lee, Y.-C. (2020). Prioritization of post-disaster reconstruction of transportation network using an integrated AHP and genetic algorithm.. *Proceedings, Construction Research Congress*. 8–10.
21. Ghannad, P., Lee, Y. C., & Choi, J. O. (2020). Feasibility and implications of the modular construction approach for rapid post-disaster recovery. *International Journal of Industrialized Construction*, 1(1), 64-75.
22. (1979). World Development Report 1979. The World Bank. <https://doi.org/10.1596/978-0-8213-7281-4>
23. Green, S. (1977). International disaster relief: toward a responsive system.
24. Leeds, A. (2013). Housing-settlement types, arrangements for living, proletarianization, and the social structure of the city. *In Third world urbanization* (pp. 330-337). Routledge.
25. Thompson, C., & Thompson, P. (1976). Preliminary Report on Post Disaster Housing in Peru. *Unpublished report to the Organization of American States*.
26. Strassmann, W. P. (1978). *Housing and building technology in developing countries*. Division of Research, Graduate School of Business Administration, Michigan State University.
27. Davis, I. (1978). Shelter after disaster. *In Shelter after disaster* (pp. 127-127).
28. International Federation of Red Cross and Red Crescent Societies. Post-disaster Shelter: Ten Designs (Geneva: IFRC; RCS, 2013).
29. Hirschon, R., & Thakurdesai, S. (1978). Housing and cultural priorities: The Asia Minor Greek refugees of 1922. *Disasters*, 2(4), 247-250.
30. Controller General of the United States, Nicaragua (1977). *An Assessment of Earthquake Relief and Reconstruction Assistance* (Washington, DC, Government Printing Office).
31. Firrone T., *Sistemi abitativi di permanenza temporanea*. Ariccia (RM): Aracne Editrice, 2010.

32. Collura, M. (1968). *Architettura del legno*. Ed. Lo Monaco.
33. Manfield, P. (2000). Modelling of a Cold Climate Emergency Shelter Prototype and a Comparison with the United Nations Winter Tent.
34. Duksi, A., & Küçükali, U. F. (2016). Sustainable Temporary Architecture. *A+ Arch Design International Journal of Architecture and Design*, 2(2).
35. Melin, N., & Melin, N. (2004). *Application of Bennett mechanisms to long-span shelters* (Doctoral dissertation, Oxford University, UK).
36. Zhang, G., Setunge, S., & van Elmpt, S. (2014). Using shipping containers to provide temporary housing in post-disaster recovery: Social case studies. *Procedia Economics and Finance*, 18, 618-625.
37. D. Sanderson, A. Sharma, J. Kennedy, and J. Burnell, “Lost In Transition : Principles , Practice And Lessons From Haiti for Urban Post-Disaster Shelter Recovery Programs vol. 6, no. 2, pp. 131–151, 2014.
38. Perrucci, D. V., Vazquez, B. A., & Aktas, C. B. (2016). Sustainable temporary housing: Global trends and outlook. *Procedia Engineering*, 145, 327-332.
39. *UN marks anniversary of devastating 2010 Haiti earthquake*. UN News. <https://news.un.org/en/story/2022/01/1109632>
40. Ritchie, L. A., & Tierney, K. (2011). Temporary housing planning and early implementation in the 12 January 2010 Haiti Earthquake. *Earthquake spectra*, 27, 487-507.
41. Sanderson, D., Sharma, A., Kennedy, J., & Burnell, J. (2014). Principles, practice and lessons from haiti for urban post-disaster shelter recovery programs. *Asian Journal of Environment and Disaster Management*, 6(2), 131-151.
42. Arslan, H. (2007). Re-design, re-use and recycle of temporary houses. *Building and environment*, 42(1), 400-406.
43. Arslan, H., & Cosgun, N. (2008). Reuse and recycle potentials of the temporary houses after occupancy: Example of Duzce, Turkey. *Building and Environment*, 43(5), 702-709.
44. Mansouri, B., Fatemi Aghda, M., & Safari, H. (2002). Preliminary earthquake reconnaissance report on the June 22, 2002 Changureh (Avaj), Iran earthquake. *Earthquake & Multi-Hazard Reconnaissance. Multidisciplinary Center for Earthquake Engineering Research (MCEER)*.
45. Bernstein, R. S., P. J. Baxter, and A. S. Buist. 1986. “Introduction to the Epidemiological Aspects of Explosive Volcanism.” *American Journal of Public Health* 76 (Suppl.): 3–9.
46. *ReliefWeb - Informing humanitarians worldwide*. (2023). ReliefWeb. <http://www.reliefweb.int/rw/dbc.nsf/doc100/OpenForm>



47. (1997). Retrieved August 10, 2023, from [http://en.wikipedia.org/wiki/1997\\_Ardabil\\_earthquake#cite\\_note-cnn-0#cite\\_note-cnn-0](http://en.wikipedia.org/wiki/1997_Ardabil_earthquake#cite_note-cnn-0#cite_note-cnn-0).
48. Lessons Learnt from Response to Lorestan Earthquake and Past Recovery Programmes in I. R. Iran, workshop, Organized by Lorestan Governor General Office, NDTF, UNDP, UNOCHA, , 27-28 June 2006.
49. Hadafi, F., & Fallahi, A. (2010). Temporary housing respond to disasters in developing countries-case study: Iran-Ardabil and Lorestan Province Earthquakes. *International Journal of Humanities and Social Sciences*, 4(6), 1326-1332.
50. Department of Human Settlements and Urban Development - Philippines and The World Bank, Post-Disaster Shelter Recovery Policy Framework: Building a Responsive System to Support Resilient and Equitable Recovery in the Philippines, 2021, 1-71.
51. Roxas, C. L. C., Cruz, O. G. D., Cruz, R. L. C. D., De Pedro, J. P. Q., Dungca, J. R., Lejano, B. A., & Ongpeng, J. M. C. (2023). Application of design for manufacture and assembly on temporary shelters in the Philipines. *Geomate Journal*, 24(103), 120-127.
52. Esplanada, Jerry E. "DPWH Drops Construction of Last Two Bunkhouses." (2014). <https://newsinfo.inquirer.net/584797/dpwh-drops-construction-of-last-two-bunkhouses>.
53. Macairan, Evelyn. "DPWH: Damaged Bunkhouses Not Permanent Shelters." (2014). <https://www.philstar.com/headlines/2014/12/09/1400628/dpwh-damaged-bunkhouses-not-permanent-shelters>.
54. *Paper Log House- Philippines Shigeru Ban Architects*. (n.d.). Paper Log House- Philippines| Shigeru Ban Architects. [http://www.shigerubanarchitects.com/works/2014\\_PaperEmergencyShelter-Philippines-2nd/index.html](http://www.shigerubanarchitects.com/works/2014_PaperEmergencyShelter-Philippines-2nd/index.html)
55. R. Maddalena, M. Russel, D. Sullivan, M. Apte, "Formaldehyde and Other Volatile Organic Chemical Emissions in Four FEMA Temporary Housing Units." American Chemical Society, 2009.
56. J. McIntosh, "The Implications of Post Disaster Recovery for Affordable Housing," 2013.
57. Wei, Y., Jin, L., Xu, M., Pan, S., Xu, Y., & Zhang, Y. (2020). Instructions for planning emergency shelters and open spaces in China: Lessons from global experiences and expertise. *International Journal of Disaster Risk Reduction*, 51, 101813.
58. Song, Y., Mithraratne, N., & Zhang, H. (2016). Life-time performance of post-disaster temporary housing: A case study in Nanjing. *Energy and Buildings*, 128, 394-404.
59. Huang, L., Long, E., & Ouyang, J. (2015). Measurement of the thermal environment in temporary settlements with high building density after 2008 Wenchuan earthquake in China. *Procedia Engineering*, 121, 95-100.

60. J. A. Peña and K. Schuzer, "Design of Reusable Emergency Relief Housing Units Using General-Purpose (GP) Shipping Containers," *Int. J. Eng. Res. Innov.*, vol. 4, no. 2, pp. 55–64, 2012
61. International Organization for Standardization. ISO/TC 104. ISO 1496-1:1990 Series 1 Freight Containers - Specification and Testing - Part 1: General Cargo Containers for General Purposes; International Organization for Standardization: Geneva, Switzerland (1990).
62. Zafra, R. G., Mayo, J., Villareal, P. J. M., De Padua, V. M. N., Castillo, M. H. T., Sundo, M. B., & Madlangbayan, M. S. (2021). Structural and thermal performance assessment of shipping container as post-disaster housing in tropical climates. *Civ. Eng. J*, 7, 1437-1458
63. Peña, J. A., & Schuzer, K. (2012). Design of reusable emergency relief housing units using general-purpose (GP) shipping containers. *International Journal of Engineering Research and Innovation*, 4(2), 55-64.
64. Onagawa Container by Shigeru Ban: Temporary Structures with Impactful Design," *Rethinking the Future*. <https://www.re-thinkingthefuture.com/case-studies/a4743-onagawa-container-byshigeru-ban-temporary-structures-with-impactful-design>
65. *Sean Godsell Architects*. (n.d.). Sean Godsell Architects. <https://seangodsell.com/future-shack>
66. Elrayies, G. M. (2017). Thermal performance assessment of shipping container architecture in hot and humid climates. *Int. J. Adv. Sci. Eng. Inf. Technol*, 7(4), 1114-26.
67. M. Starr, "World's first 3D-printed apartment building constructed in China - CNET", CNET, 2016. [Online]. Available: <http://www.cnet.com/news/worlds-first-3d-printed-apartment-building-constructed-in-china>
68. Galindo, G., and Batta, R. (2013). Review of recent developments in OR/MS research in disaster operations management, *European Journal of Operational Research*, Vol. No. 0, pp.
69. Gregory, M., Hameedalden, S. A., Intumu, L. M., Spakousky, J. J., Toms, J. B., and Steenhuis, H. J. (2016). September. 3D printing and disaster shelter costs. In 2016 Portland International Conference on Management of Engineering and Technology (PICMET) (pp. 712-720). IEEE
70. Khajavi, S. H., Partanen, J., and Holmström, J. (2014) Additive manufacturing in the spare parts supply chain, *Computers in Industry*, Vol. 65, No. 1, pp. 50-63.
71. Tay, Y. W. D., Panda, B., Paul, S. C., Noor Mohamed, N. A., Tan, M. J., and Leong, K. F. (2017). 3D printing trends in building and construction industry: a review. *Virtual and Physical Prototyping*, 12(3), pp.261-276.
72. Subramanya, K., & Kermanshachi, S. (2021). Exploring Utilization of the 3D Printed Housing as Post-Disaster Temporary Shelter for Displaced People. *Construction*

*Research Congress 2022* (pp. 594-605).

73. Sakin, M., and Kiroglu, Y. C. (2017). 3D Printing of Buildings: Construction of the Sustainable Houses of the Future by BIM. *Energy Procedia*, 134, 702-711.
74. Dancel, R. (2019). 3D Printed House for Disaster-Affected Areas. In *Disaster Risk Reduction and Infrastructure Development (DRRID) Forum*.
75. W. (2023). *Essential Homes Research Project launches first shelter for displaced communities*. wallpaper.com. <https://www.wallpaper.com/architecture/norman-foster-foundation-essential-homes-venice-italy>
76. Archiproducts. (2023) A Sustainable Dwelling Module by Norman Foster. Archiproducts.com [https://www.archiproducts.com/en/news/prefabricated-sustainable-house-by-foster-at-the-venice-architecture-biennale\\_94493](https://www.archiproducts.com/en/news/prefabricated-sustainable-house-by-foster-at-the-venice-architecture-biennale_94493).
77. Gunawardena, T., Ngo, T., Mendis, P., Aye, L., & Crawford, R. (2014). Time-efficient post-disaster housing reconstruction with prefabricated modular structures. *Open house international*, 39(3), 59-69.
78. Sphere Association, *The Sphere Handbook: Humanitarian Charter and Minimum Standards in Humanitarian Response*, (Geneva: 2018)
79. Karsa, K. R., & Wardani, L. K. *Humanitarian Shelter Guidelines: Indonesian Version*. *Smart City*, 2(2), 1.
80. Layaoen, C. (2022). *Emergency Architecture: A Temporary Housing Solution for Post-disasters in Hawaii* (Doctoral dissertation, University of Hawai'i at Manoa).
81. Pérez-Valcárcel, J., Muñiz, S., Mosquera, E., Freire-Tellado, M., Aragón, J., & Corral, A. (2021). Modular temporary housing for situations of humanitarian catastrophe. *Journal of Architectural Engineering*, 27(2), 05021004.
82. United States: Hurricane Katrina - Situation map - United States of America. (2005, August 30). Retrieved from <https://reliefweb.int/map/united-states-america/united-states-hurricane-katrina-situation-map>
83. Boothroyd, G. (2005). *Assembly automation and product design*. crc press.
84. HHi Temporary shelter Solution for Haiti. (n.d.). Retrieved September 7, 2023, from <http://www.humanitarianhouseinternational.com/>
85. M6.1 Western Iran Earthquake of 31 March 2006 - Iran (Islamic Republic of). (2006, March 31). Retrieved from <https://reliefweb.int/map/iran-islamic-republic/m61-western-iran-earthquake-31-march-2006>
86. Haugan, I. (2015, January 16). Students rebuild an orphanage after Typhoon Yolanda. Retrieved September 7, 2023, from <https://partner.sciencenorway.no/aid-climate-development-aid/students-rebuild-an-orphanage-after-typhoon-yolanda/1412901>

87. Rafferty, J. P., & Pletcher, K. (2023, September 6). Super Typhoon Haiyan | 2013, Northern Pacific Ocean. Retrieved September 7, 2023, from <https://www.britannica.com/event/Super-Typhoon-Haiyan>
88. G. P. A. (2014, April 15). Investigative Documentaries: Caibaan Motocross Bunkhouses in Tacloban lack supply of clean water. Retrieved from <https://www.youtube.com/watch?v=ajXjOzv6n9o>
89. Ban. (n.d.). Paper Log House, Cebu. Retrieved September 7, 2023, from <https://arquitecturaviva.com/works/paper-log-house-cebu-philippines>
90. Hany Abulnour, A. (2014). The post-disaster temporary dwelling: Fundamentals of provision, design and construction. *Hbrc Journal*, 10(1), 10-24.
91. Katrina Cottages. (n.d.). Retrieved September 7, 2023, from <https://katrinacottagehousing.org/original.html>
92. Rafferty, J. P., & Pletcher, K. (2009, October 15). Sichuan earthquake of 2008 | Overview, Damage, & Facts. Retrieved September 7, 2023, from <https://www.britannica.com/event/Sichuan-earthquake-of-2008>
93. Ban. (n.d.). Container Temporary Housing, Onagawa. Retrieved September 7, 2023, from <https://arquitecturaviva.com/works/viviendas-temporales-container-3>
94. Sean Godsell Architects. (n.d.). Retrieved September 7, 2023, from <https://seangodsell.com/future-shack>
95. Apis Cor | Construction with Robotic Precision – Apis Cor | We Print 3D Buildings. (n.d.). Retrieved September 7, 2023, from <https://www.apis-cor.com/>
96. Subramanya, K., & Kermanshachi, S. (2021). Exploring Utilization of the 3D Printed Housing as Post-Disaster Temporary Shelter for Displaced People. In *Construction Research Congress 2022* (pp. 594-605).
97. Giulia Capozza. (2023, June 21). A Sustainable Dwelling Module by Norman Foster. Retrieved July 7, 2023, from [https://www.archiproducts.com/en/news/prefabricated-sustainable-house-by-foster-at-the-venice-architecture-biennale\\_94493](https://www.archiproducts.com/en/news/prefabricated-sustainable-house-by-foster-at-the-venice-architecture-biennale_94493)
98. Wilkes, D. (2023, March 2). Structural Insulated Panels and Ground Screws: A Perfect Match. *Stop Digging UK*. <https://stopdigging.co.uk/news/structural-insulated-panels-and-ground-screws-a-perfect-match/#:~:text=One%20of%20the%20best%20foundation,is%20screwed%20into%20the%20ground.>)
99. Guide to Foundation and Support Systems for Manufactured Homes: March 2002 | HUD USER. (n.d.). <https://www.huduser.gov/portal/publications/destech/foundations.html>
100. Installation & FAQs. (n.d.). SIPS Ground Screws. <https://sipsgroundscrews.co.uk/pages/installation-faqs>

101. Robins, M. (2023, July 11). *The ABCs of SIPs - Metal Construction News*. Metal Construction News. <https://www.metalconstructionnews.com/articles/the-abcs-of-sips/>
102. *Structal Building Systems*. (n.d.). Structall Building Systems. <https://structall.com/apps/help-center#hc-why-is-the-snap-n-lock-sip-better-than-osb-sips-1>
103. Panjehpour, M., Ali, A. A. A., & Voo, Y. L. (2013, January 31). Structural Insulated Panels: Past, Present, and Future. *Journal of Engineering, Project, and Production Management*, 3(1), 2–8.
104. Meis, A. (2015). The True Cost of SIPs: A Comprehensive Tool for Comparing the Price of Residential Structural Insulated Panel and Stick Frame Construction.
105. SIP Installation Cost Estimating Guide - Innova Panel. (2022, October 20). Innova Panel. [https://innovapanel.com/building\\_kit-2/sip-estimating-guide/](https://innovapanel.com/building_kit-2/sip-estimating-guide/)
106. SIP Panel Cost Guide. (n.d.). Checktrade. Retrieved November 12, 2023, from <https://www.checktrade.com/blog/cost-guides/sip-panel-cost/>
107. SIPs vs Stick Built Framing | Benefits of Structural Insulated Panels | Thermocore. (n.d.). <https://www.thermocore.com/sips-vs-stick-built>
108. Ground Screw Calculator. (n.d.). <https://www.groundscrewcentre.co.uk/products.asp?page=calculator>
109. *Installation Guide*. (n.d.). Structall Building Systems. <https://structall.com/pages/installation-guide/>