



**Politecnico
di Torino**

Master's Thesis in Architecture

Parametric Design in Structural Optimization

Calculating an optimization of Geodesic domes structure through
Parametric modeling

Supervisors:

Prof. Marano Giuseppe Carlo

Laura Sardone

Candidate:

Vida Maghsoudloumotlagh

Academic Year 2022/2023

Contents:

1. Abstract	1
2. Geodesic Domes Introduction	3
3. Optimization problems	6
3.1. introduction.....	6
3.2. Structural Optimization.....	7
4. Parametric Design	9
4.1. introduction.....	9
4.2. computational Design.....	10
5. Methodology (parametric software and algorithms)	12
5.1. Literature review.....	12
5.2. parametric design software.....	15
5.3. concept of algorithm.....	24
5.3.1. the nature of the generative design.....	27
5.3.2. introduction to genetic algorithms.....	31
5.4. topology and form finding.....	36
5.4.1. grasshopper and karamba.....	38
5.4.2. The Galapagos.....	38
5.4.3. The pufferfish.....	38
5.4.4. Kangaroo.....	39
5.4.5. Finite element analysis.....	39
5.4.6. Evolutionary genetic algorithms.....	41
5.4.7. Alpaca4D- structural analysis tool.....	43
5.4.8. Python scripting in grasshopper.....	44
6. some example of Geodesic Domes	45
6.1. The Dome at Biosphere 2 (Arizona, USA)	45
6.2. Eden Project (Cornwall, UK)	46
6.3. Montreal Biosphere (Quebec, Canada)	49

6.4. Epcot Center's Spaceship Earth (Florida, USA)	49
7.A prototype of Geodesic Domes shelter.....	52
7.1. Introduction.....	52
7.2. Geodesic Domes Shelter Plans.....	53
7.3. Geodesic Domes shelter 3D models.....	54
8. Geodesic Domes generative design.....	56
8.1. generate a mesh IcosPHERE.....	56
8.2. Mesh rotation on mid geodesic line.....	57
8.3. List of positive mesh edges(+z)	59
8.4. List of positive points (+z)	60
8.5. the split line on the XY plane.....	62
9. Geodesic Domes structural optimization.....	63
9.1. Structural Analysis with Alpaca4D.....	63
9.2. Size Optimization.....	66
9.3. parametrized frequency.....	69
9.3.1. frequency order 1.....	69
9.3.2. frequency order 2.....	71
10.Conclusion.....	74
11.Bibliography.....	76
12.Acknowledgements.....	77

1. Abstract:

Our current global environment is characterized by a lack of safety in relation to natural catastrophes. However, significant advancements have been accomplished thus far in disaster prevention and mitigation, particularly in response to events such as floods, earthquakes, and other similar occurrences. It is imperative that we are well prepared to coordinate and provide assistance to the affected individuals.

In light of the global impact of the COVID-19 outbreak, which has already subsided. The recent earthquake in Turkey and Iran revealed that the tents provided inadequate protection against aftershocks and inclement weather conditions such as wind, rain and snow. Consequently, there is a need to explore alternative shelter options, such as prefabricated structures like geodesic domes, which offer numerous advantages, and serves as an alternative to traditional shelters. These advantages include quicker assembly, better use of resources. The optimal design of geodesic domes as prefabricated shelter structures is investigated in this work, with a particular emphasis on horizontal loads like wind. The results can be applied and generalized to seismic activity.

Moreover, there has been a noticeable shift in the fields of architecture and design in recent years toward the usage of new and efficient design techniques. The use of Grasshopper, a visual programming plugin built for Rhino, facilitates the use of metric modeling, which has received a lot of attention. Ultimately, the current study looks at the use of Grasshopper and parametric modeling approaches in the field of Geodesic dome constructions and structural optimization. The goal of this thesis is to look into Grasshopper's capabilities for creating, analyzing, and optimizing Geodesic dome structures. Our goal with parametric modeling is to optimize the design process, increase structural durability.

Designers can engage in an iterative process embracing a wide range of design options by utilizing Grasshopper's computational capabilities. This enables them to investigate several structural alternatives and, as a result, improve their projects with a high degree of accuracy and efficiency. Furthermore, the use of Grasshopper simplifies the modeling and evaluation of structural efficacy. In order to minimize the overall volume of the frame structure and its connections, the optimization of geodesic domes is the main topic of this thesis. The base radius of the dome is taken into consideration as a shape constraint during the

optimization stage. The ability to change the frame number due to frequency variability affects the structural topology and shapes the sections (shape optimization). In the chapter 9, the construction aspects for the assembly of a geodesic dome are taken into account along with self-weight and asymmetric load actions. During the optimization stage, Finite Element Analysis (FEA) results are exploited by evolutionary genetic algorithms (EAs).

By utilizing this tremendous instrument's powers, designers have the potential to push the boundaries of imagination, and productivity, introducing a new era of architectural study and growth.

2. Geodesic Domes Introduction:

Geodesic domes, which are derived from geodesic polyhedrons, are remarkable thin-shell structures with a hemispherical shape. Despite their compact size, geodesic domes have the ability to withstand substantial loads due to the structural rigidity of their triangular components that uniformly distribute structural stress throughout the entire structure. Since the construction of the first geodesic dome in Jena, Germany in 1922, numerous studies have been conducted to further understand the intricacies and potential of these innovative architectural marvels. It is important to acknowledge that the credit for making this advance possible goes to R. Buckminster Fuller. The versatility of geodesic domes arises from their distinctive qualities, which allow them to serve a wide range of purposes including expositive pavilions, residential modules, greenhouses, and even water reservoirs. The unique design and inherent strength of geodesic domes continue to captivate researchers and architects alike, inspiring further exploration and innovation in the field of structural engineering.

The composition of a geodesic dome's structure consists of a multitude of struts or beams that intersect in a manner that creates either polygonal or triangle-shaped panels. Geodesic domes exhibit remarkable strength and resilience, enabling them to endure a wide range of loads and environmental circumstances due to the panels' capacity to evenly disseminate the structural stress across the entirety of the framework.



Figure 01 – Zeiss Planetarium by Dr Walther Bauersfeld; Carl Zeiss Optics Corporation, Jena, Germany (1926).

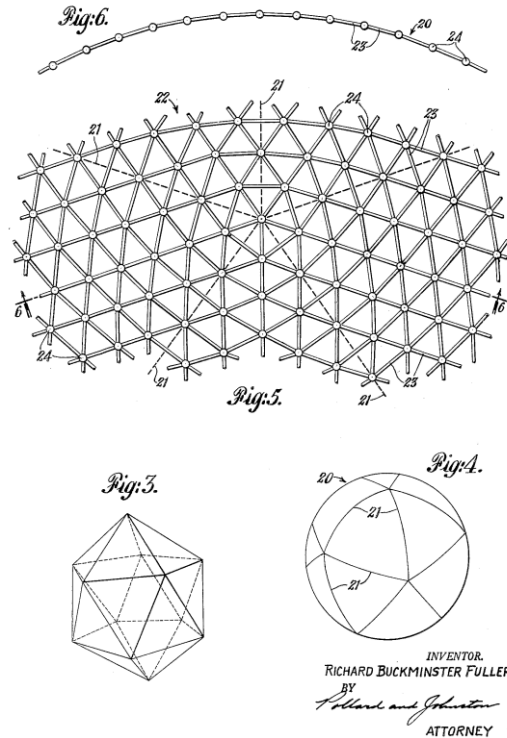
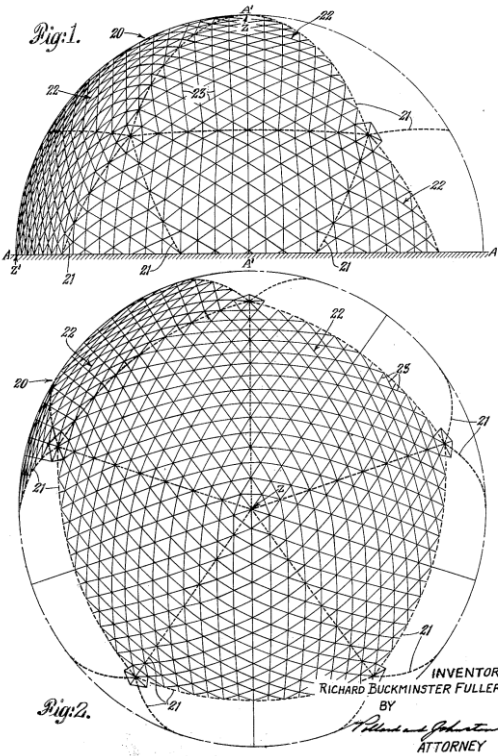

Figure 02 – Geodesic Dome representation by Fuller Richard Buckminster, June 1954. Patent US261168A.

The inherent strength of triangles plays a crucial role in upholding the structural integrity of geodesic domes, a fact that can be attributed to their natural robustness. By ingeniously interconnecting numerous triangles, it becomes possible to create a structure that is both sturdy and unwavering owing to the rigidity and stability inherent in triangles. Consequently, as more and more triangles are integrated into the design of the dome, its resilience and durability experience a substantial boost. Compared to conventional architectural forms, geodesic domes have a number of advantages. First off, their spherical or partially spherical shape facilitates effective load-bearing capacity and stress distribution. Geodesic domes are more cost-effective to construct because of their structural efficiency, which requires less material when compared to conventional buildings of a similar size. The improved interior space utilization offered by geodesic domes' distinctive shape. Open and flexible floor plans are possible because the interior can be easily modified to suit different needs because there are no load-bearing walls or internal columns. Furthermore,

natural ventilation and effective airflow are encouraged by the curved shape of geodesic domes. Applications for these structures are numerous and include exhibition spaces, greenhouses, residential homes, recreational centers, and even habitats for space exploration. They are well-liked options in many sectors and situations due to their flexibility and adaptability.

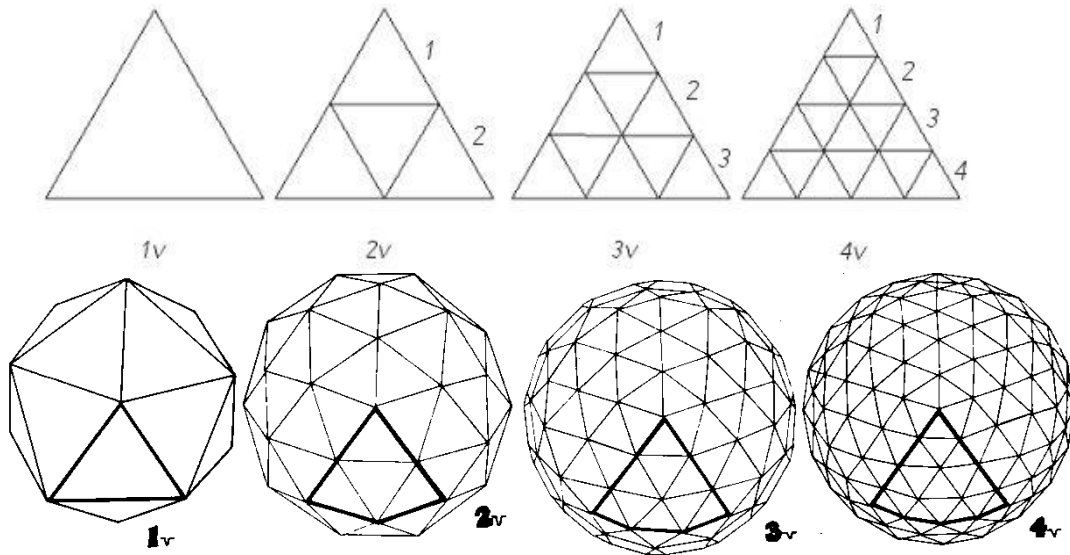

Figure 03 – Icosahedron frequencies with alternate breakdown

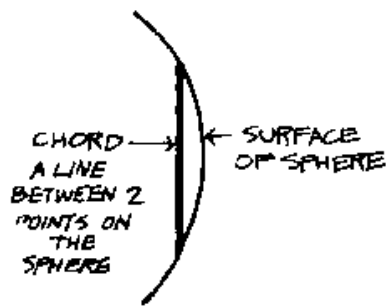

Figure 04 – Chord and sphere surface

Considering the widespread use of geodesic domes in the AEC industry and the ongoing research on this type of structure, this thesis takes into account the self-weight and the action of the asymmetrical horizontal load (wind action). We perform the FEM analysis using Alpaca 4D, a Grasshopper plugin that is built on top of Open Sees. Last but not least, the geodesic dome's frame size is optimized using the meta-heuristic-based Galapagos solution. A Python script is then implemented that processes the structural analysis results using the Iron-Python component that was created in the Grasshopper environment.

3. Optimization problems:

The modeling and analysis of optimization problems are valuable in a wide variety of fields of research, including engineering, economics, and other exact sciences. The study of optimization, sometimes known as "optimization," is a branch of research that focuses on the determination of valuable models that are currently in use through the application of effective methods. This has resulted in a great interest in the present era, from both a scientific and a technical point of view, in the discovery and advancement of such models that have the capacity to effectively solve a number of different complicated challenges.

3.1. introduction:

The process of maximizing or decreasing a specific function about a certain set is referred to as optimization. This procedure often indicates several options that are possible within a specific context. The function makes it easier to evaluate and contrast several possibilities in order to select the alternative that provides the greatest benefit. Inside the field of mathematics, the idea of optimization refers to the process of determining which values of the variables contained inside a particular function produce the best results in terms of either the minimum or maximum value of the output. It is strongly suggested, and at the least useful, for the designer to seek an optimal solution throughout the design process by applying specialized models known as mathematical optimization models. This is because it is very beneficial for the designer to do so. These models make it easier to determine the parameter values that can successfully maximize or decrease the functions that are desired. The construction of an optimization model can be broken down into four primary stages, which are as follows:

The first thing that has to be done in the research process is to determine the problem that needs to be solved. At this early stage, it is essential to have a clear understanding of the nature of the issue at hand, to have an in-depth knowledge

of the goals of the decision-making process, and to have an understanding of the constraints that the optimal solution must satisfy.

The next thing that needs to be done is the definition of the variables. Establishing precise definitions for the decision variables in the model is of the greatest significance. These decision variables correlate to the various options that are considered during the process of decision-making.

The target will illustrate their point in the following. It is essential to determine the model's objective function, which can be either minimized or maximized depending on the context. Within the context of the optimization process, this objective function is derived from the design factors that are open to unlimited modification.

In the end, it is required to define and illustrate a set of restrictions that regulate the operation of the aim, if that is acceptable. The limitations that were discussed before indicate some requirements that the optimal solution to the optimization problem must meet.

3.2. Structural Optimization:

The resolution of optimization problems is an essential part of the design process in engineering. The goal of these problems is to determine the design solution that minimizes or maximizes a particular objective function while remaining faithful to a set of established limits. There are three basic forms of optimization that may be identified within the field of structural optimization. This is achievable because of the particulars of the design components. When the design factors are directly linked to the dimensions of the parts, there is a requirement for sizing optimization to take place. When there is previous understanding about the layout and shapes of the parts of the structure, and when there is a desire to discover the most appropriate dimensions, the employment of this approach becomes advantageous. Individuals have the capacity to select the design variables that regulate the configuration of the borders of the components when the level of analysis is elevated to a higher level. This specific decision will lead to the optimization of the shape. When it is known how the members will be arranged and where they will go, shape optimization is a technique that can be used. Utilizing this approach makes it easier to choose the best possible member forms. It is necessary to implement topology optimization strategies in order to improve the effectiveness of a system's topology, connection, or architecture. The manipulation of design factors, which regulate the layout and interaction of design elements, is an essential part of topology optimization.

It is possible to state that a new category can be developed by merging two or more of the categories that have been described in the past because there is some degree of overlap between these categories. The fundamental purpose of this research is to improve the efficiency of geodesic domes by minimizing the overall volume occupied by the frame structure and the connections between the dome's individual components. During the phase of optimization in which the shape is being optimized, the base radius of the dome is treated as a fixed value and acts as a constraint on the shape. The ability to change the total number of frames present in a structure is referred to as its frequency variability, and it permits the structural topology of that structure to be altered. This modification has an effect on the shape of the parts, which makes it possible to optimize the shape.

A higher level of challenge is presented by the integration of structural optimization strategies into the building design process as well as the design of civil and structural engineering buildings.

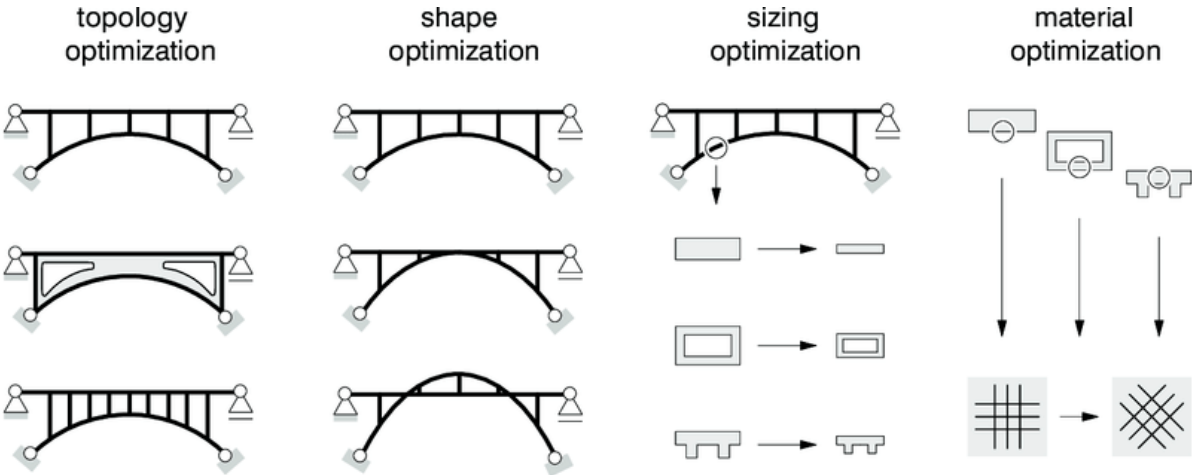

Figure 05 – Structural optimization types

4.Parametric Design:

4.1. introduction:

The previous chapter discussed how optimization techniques and technology improvements aid the design process, highlighting the significance of finding optimal solutions throughout the process. Parametric formulation of the design problem is often required for optimization. The objective and constraint functions are mostly guided by design parameters. Form minimization for big structures, either continuous or discrete, requires many project variables due to the quantity of nodes. To solve this, parametric geometry functions with few parameters may be useful. These factors can be made shape optimization variables for the issue.

This chapter introduces parametric design and the important high-performance design tools used in structural optimization's first stages. Designers enter parameters into software platforms to create these systems. These parameters are processed by the software in a dedicated framework. Computational design is widely acknowledged as the methodology that enables parametric design. The definition shows that computational design, unlike conventional methods, allows a shift from representational logic to three-dimensional simulation of the architectural object.

Parametric design refers to a computational approach employed by designers to generate and control design elements through the application of predetermined parameters or rules. This particular methodology enables architects to generate sophisticated and elaborate structures, as every component is intelligently interconnected and adapted to one another according to a predefined set of parameters. A parametric design system employs algorithms and mathematical equations to manipulate individual design elements, consequently establishing its reputation as an exceptionally effective method for achieving complicated forms and structures. Parametric design in the field of architecture uses computational methods to generate detailed and unique designs that are systematically adapted to meet distinct requirements and limitations, covering both aesthetic and practical considerations. Instead of employing static drawings or sketches, parametric design software enables designers to input design parameters and algorithms to develop and manipulate designs.

Parametric design is a prevalent approach employed in the field of architecture to conceive and develop buildings characterized by distinctive forms that are precisely customized to meet specific requirements and site-specific limitations. Parametric design can be utilized to generate architectural elements such as the geometry of a music hall's undulating, curved ceiling or the configuration of a

building face that optimizes the intake of natural light. The utilization of parametric design in architectural practice enables the enhancement of building structure performance using a process referred to as structural optimization. The field of structural optimization employs advanced computer techniques and simulations to assess and enhance the structural performance of structures and their elements, including beams, columns, and trusses.

Parametric design is a valuable tool that enables architects to swiftly and effectively implement modifications and adaptations in response to client requirements and project limitations. A parametric design system enables designers to control a model by adjusting parameters, hence eliminating the need to begin the design process anew whenever modifications are desired. Hence, architects have the capability to generate numerous design choices and revisions within a shorter timeframe, thereby facilitating a more adaptive and simplified design process. By inputting specified requirements, such as load-bearing capacity, material strength, and space limits, designers can use parametric design to develop optimum structural systems that are capable of achieving these needs utilizing minimal material usage, and consequently, cost. This phenomenon has the potential to result in the development of buildings that exhibit enhanced efficiency, sustainability, and structural integrity.

In general, parametric design enables architects to generate complex shapes and structures while simultaneously optimizing building performance. This is achieved through the utilization of computer analysis, which facilitates the evaluation of several factors such as energy efficiency, structural stability, and thermal comfort. Architects can generate structures with distinctive forms and functionalities that are optimized for safety, cost-effectiveness, and performance by integrating parametric design with structural optimization techniques. The previously mentioned methodology is gaining attention due to its potential to generate novel, environmentally friendly constructions that possess visually captivating aesthetics and economic feasibility.

4.2. computational Design:

The term "computational design" refers to the practice of employing digital tools and software during the design process with the intention of creating environments or structures that display improved levels of effectiveness, efficiency, and optimization. The procedure requires the application of complex algorithms, huge data sets, and modeling techniques in order to assist the fabrication of innovative forms, combinations of materials, and functional arrangements that were not before feasible. Computational design, in its most basic form, gives architects and designers the ability to make use of computer

technology for the purposes of modeling, testing, and iteratively refining a number of different design cycles before the start of the actual physical construction.

The amount of automation that is employed in computational design in comparison with parametric design, is one of the most prominent differences between the two. The application of automated methods, such as machine learning and other forms of artificial intelligence technology, is a common practice in the industry of computational design, which aims to enhance and improve the design process. The primary focus of parametric design, on the other hand, is the modification of the design's input parameters, which allows for the generation of a wide variety of design iterations. This method requires the structural components to undergo manual adjustment of characteristics such as size, form, and location.

The extent to which design issues were taken into account is yet another important difference. Computational design places a primary emphasis on resolving complex technical difficulties relating to building performance. These challenges span a wide range of elements, including energy efficiency and structural stability, among others. On the other hand, parametric design is widely used to assist the process of discovering and molding shapes, in addition to addressing issues relevant to aesthetics. This is because parametric design may take into account multiple variables simultaneously. The combination of the two methods has the potential to provide a synergistic effect, which would result in a streamlined design process that maximizes the functionality of the building while preserving its aesthetically pleasing style. This might be accomplished by utilizing computational design tools.

Both computational design and parametric design have revolutionized the design process by enabling designers to investigate inventive and efficient resolutions to intricate challenges. This has resulted in architectural creations that seamlessly blend creative expression with practical functionality. Despite their inherent differences, computational design and parametric design have both contributed to this revolution.

5.Methodology (parametric software and algorithms):

5.1. Literature Review:

In addition to having to deal with the ever-increasing complexity of structural design, engineers are being asked to increase the amount of work they get done in the same amount of time. The modern design tools for architecture have substantially expanded the field of possibilities for including complicated curves and elaborate structural features. These technological breakthroughs have made it possible for structural engineers to create designs that are visually stunning and are now widely used in their work. Nevertheless, it is essential to point out that these specialists are today confronted with the difficulty of operating within restricted budgetary resources and more stringent project deadlines. Structural engineers have been forced to explore the domain of algorithmically enabled parametric modeling, which is also referred to as parametric design. This has been caused by the limits that were discussed before.

Both "parametric design" and "parametric modeling" are two unique topics that have to be discussed further. Establishing parameters, which may be thought of as data inputs that are tightly tied to the entities being represented, is the cornerstone of parametric design. Parameters can be thought of as the building blocks of a model. When one parameter in a model is changed, such as when the number of columns or the width of a deck is increased or decreased, all of the model objects that are affected by this adjustment are immediately altered. By combining parametric design with an appropriate parametric Building Information Modeling (BIM) tool, it is possible to use parameters to not only alter geometric aspects but also generate extensive BIM data. This is made possible through the application of parametric design. Therefore, the benefits of parametric building information modeling (BIM) extend quite a bit.

By utilizing an editor that is algorithm-based, the practical application of algorithm-enabled parametric Building Information Modeling (BIM) makes it possible for structural engineers to easily create data input schema. This is made possible through the utilization of the Building Information Modeling (BIM) software. After that, the objects that were formed can be exported into a parametric building information modeling (BIM) tool for additional analysis and manipulation.

Thanks to the combination of Building Information Modeling (BIM) software with visual programming tools like Grasshopper, structural engineers in modern practice are able to efficiently utilize this workflow even in the lack of knowledge in programming. This is made possible by the integration of the two technologies.

This smooth connection is made possible through the use of Grasshopper, which is a plugin that comes pre-installed with Rhinoceros 6, a well-known 3D computer graphics and computer-aided design (CAD) tool. The application of this method yields particularly beneficial results when it comes to the construction of complex forms such as curved structures and design concepts that are architecturally sophisticated.

The specification of input parameters, such as coordinates, dimensions, curves, or complicated NURBS, is made possible by the integration of a visual programming editor, such as Grasshopper, into the workflow of the design process. Grasshopper is one example of such an editor. After that, you may use visual scripting to construct rules that will alter these factors, which will ultimately result in the development of the desired geometry or other output. This output can then be directly applied to dynamic objects within parametric BIM software, which incorporates the necessary qualities to satisfy industry standards. This process can be carried out in a circular fashion.

If you make any changes to the design, those changes will automatically be propagated all the way through the model, taking into account the attributes that you have chosen to specify. The Grasshopper software application, in its most basic version, receives input from users, carries out any necessary calculations, and produces outputs that correspond to those inputs.

The model incorporates the results of the run. This eliminates the need to manually apply alterations throughout the model and enables the rapid production and visualization of several iterations of sophisticated designs in three dimensions by simply adjusting the attributes. Additionally, this eliminates the need to manually implement modifications throughout the model. When used to the modeling of complex buildings with sophisticated geometries and curved surfaces, such as geodesic domes, this method exhibits special advantages that make it very useful.

When combined with parametric modeling, and more specifically algorithmically-driven parametric Building Information Modeling (BIM), parametric design has the potential to effectively address the aforementioned requirements by means of a streamlined workflow that primarily focuses on simplifying the process of modeling intricate geometries. This enables parametric design to effectively address the requirements listed above.

This tool makes it possible to conduct an in-depth investigation of design possibilities while also enabling quick iteration of structural shapes.

5.2. Parametric Design Software:

There is a noticeable demand for sophisticated geometrical arrangements that can be adapted to individual requirements in the current climate of contemporary architecture and design. This demand may be seen in a number of different contexts. These intricate geometries are an essential component in the process of establishing the overall structure, form, and dimensions of constructions. The increasing need for architectural designs that are both modern and forward-looking has resulted in the development of innovative techniques and technology, such as computer-aided design (CAD), which are now used in the profession of architecture. This idea refers to the process of using computing technology to improve one's ability to see and visualize a design in a more accurate manner.

Because of its capability to produce consistent precision and high quality, the tool is frequently used for the goal of producing, reviewing, changing, and finally exhibiting the design. This is due to the tool's ability to deliver on these promises. On the other hand, parametric design refers to the use of parameters, which might include constraints, interconnections among geometric entities, dimensions, as well as the shape and size of these things, amongst other considerations. The association between the design aim and the design response may be established in large part thanks to the contributions made by these various aspects. They are essential in the process of algorithmically constructing the necessary framework and shape of the model, which will be demonstrated in the following steps.

The following is a list of the key software packages that designers that are interested in developing parametric design projects often use:

Grasshopper 3D:

Rhinoceros 3D is the host application for the software plug-in known as Grasshopper 3D, which was formerly known as Explicit History. It provides users with a graphical programming language interface that makes it easier to create and modify geometric objects.

Individuals will put different components or nodes onto a canvas as part of the process of developing a grasshopper definition. Graphs, as they are known in the realm of discrete mathematics, are put to use by the Grasshopper software to show the flow of interactions between parameters and user-defined functions (also known as nodes). Following this procedure will, in the end, result in the formation of geometric shapes. Changing parameters or making alterations to the geometry will result in the propagation of these modifications throughout all functions, which will force you to redraw the geometry.

The Grasshopper canvas, featuring nodes, pertains to a visual programming framework known as Grasshopper. This framework functions as a plugin within the context of Rhinoceros 3D, a widely recognized software for 3D modeling, generally referred to as Rhino. The Grasshopper software facilitates the generation of intricate parametric models through the interconnection of diverse nodes on a graphical interface, catering to the needs of designers, architects, and engineers.

The canvas in Grasshopper serves as the primary workspace for constructing parametric models. The software offers a visual interface that enables users to interact with nodes through a drag-and-drop mechanism. Users can establish connections between nodes and create relationships among them, thereby facilitating the generation and manipulation of geometric elements.

In the Grasshopper software, nodes are graphical representations of distinct components that are designed to execute certain actions or operations. Mathematical operations, geometric transformations, data manipulation tools, and bespoke scripts are all examples of the various types of functions that can be utilized. In the context of data flow or algorithmic chains, it is observed that each node possesses both inputs and outputs. By establishing connections between the outputs of one node and the inputs of another, a coherent data flow or algorithmic chain can be established.

The establishment of connections among nodes serves to delineate the underlying logic and interdependencies that govern the parametric model. By adjusting input parameters or altering the node network's topology, the model will automatically update, enabling quick exploration of many design iterations and variants.

The utilization of Grasshopper is prevalent in various domains, including architecture, industrial design, computational design, and engineering. This software empowers designers to fabricate intricate structures, produce patterns, simulate behaviors, and investigate design potentials through a versatile and user-friendly approach.

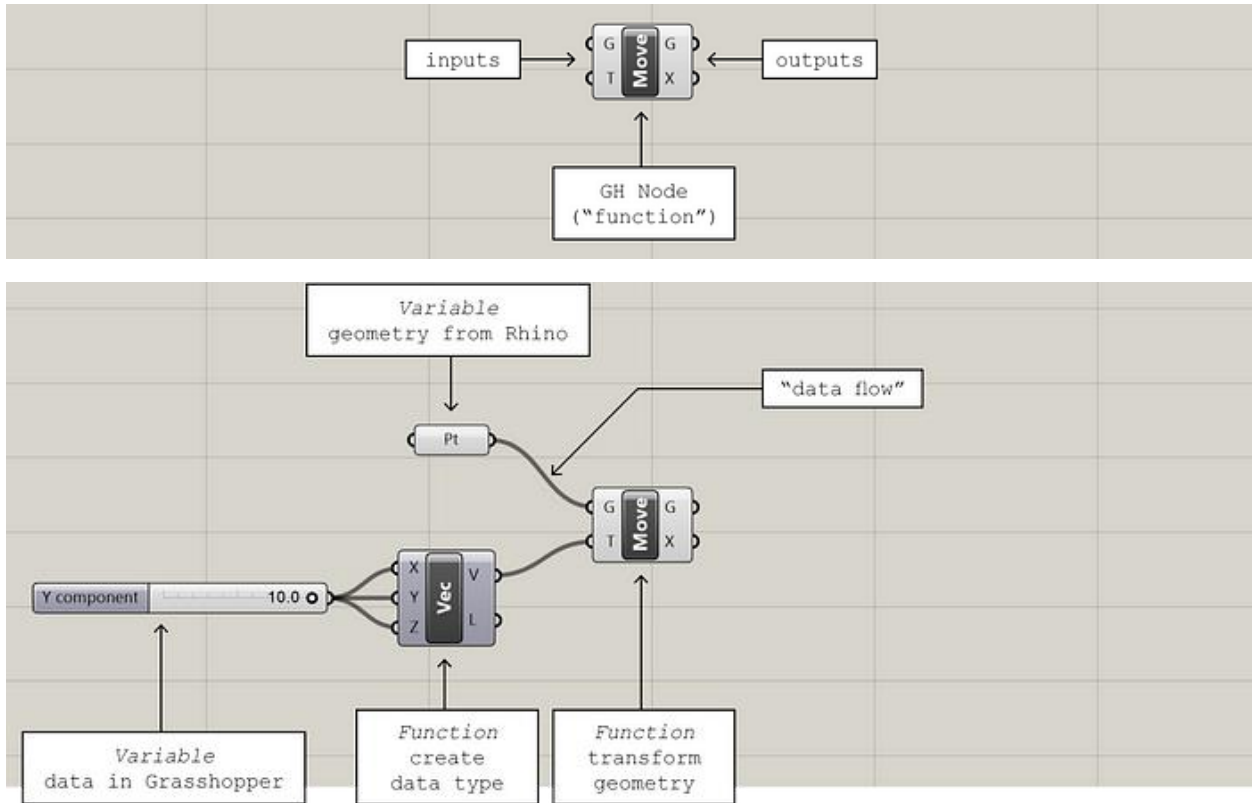

Figure 07 – The Grasshopper canvas

Autodesk Revit:

This article is about the software application known as Autodesk Revit, which was developed by Autodesk Inc. and is used extensively in the fields of architecture, engineering, and construction.

Building information modeling (BIM) is accomplished through the use of a software tool called Autodesk Revit. This application is utilized by architects as well as other construction industry experts. The need for software that could generate three-dimensional parametric models that included both geometric and non-geometric design and construction data served as the impetus for the development of Revit. When using the Revit program, each change made to an element will cause an automatic propagation procedure to be triggered throughout the entire model. This will guarantee that all components, views, and annotations will remain consistent. This not only makes the process of collaborating amongst teams easier, but it also ensures that all pertinent information, such as floor areas and timetables, is instantly updated in real time whenever the model is modified.

Autodesk Dynamo:

Dynamo is a piece of software that may be used in the design industry to simplify the process of graphical programming, and it is made accessible as an open source platform. Incorporating a graphical algorithm editor that takes into account both data and logic components is one of the ways in which Dynamo expands the capability of generating information modeling.

Autodesk 3ds Max:

A program known as Autodesk 3ds Max is a piece of software that provides users with a vast assortment of functions for the purpose of parametric 3D modeling. It comprises a number of features such as modeling, animation, simulation, and rendering, and it is designed to meet the requirements of a variety of sectors including gaming, film production, and motion graphics. In order to control the application's geometric properties, the software program known as 3ds Max makes use of wired parameters and other modifiers. Users are given the option to script and customize the operation of it whatever they see fit as a result of this. The Max Creation Graph, sometimes known as MCG, is a node-based visual programming environment that can be found within the 3ds Max 2016 software and is used for the creation of tools. It is comparable in appearance to other tools such as the Grasshopper and the Dynamo.

CATIA:

Catia, which stands for Computer Aided Three-Dimensional Interactive Application, was used in the design process for the creation of the Guggenheim Museum Bilbao as well as other prominent curvilinear constructions designed by architect Frank Gehry. Since then, the technology section of the architecture firm lead by Frank Gehry known as Gehry Technologies has developed a unique parametric design software known as Digital Project. This software draws upon the knowledge and experience that the Gehry Technologies team gathered while working with catia.

Power Surfacing:

The term "Power Surfacing" refers to a computational method that is utilized in computer-aided design (CAD) that makes it possible to SolidWorks is a popular computer-aided design (CAD) application, and the software tool known as Power Surfacing was designed expressly for use with SolidWorks. This application was developed to make it easier to create complicated and sophisticated surface and solid models, which are frequently employed in the fields of industrial design and freeform organic design respectively. Because of the direct connection between

the program and SolidWorks, it is compatible with all of the instructions that are contained within the SolidWorks platform. It is investigated how to perform reverse engineering on scanned meshes by making use of Power Surfacing RE.

Generative Components:

In the year 2003, Bentley Systems released their software product known as Generative Components for the very first time. Bentley Systems was the company that initially developed this program. Early in 2005, it had already established a strong following in London's architectural world, and by November 2007, it had been formally released for general public consumption. Academic institutions and design firms with a high level of technological sophistication make up a significant portion of Generative Components' user base. A citation absolutely needs to be included in order to back up the information that was presented. Commonly used as a shorthand for Generative Components, the term 'GC' refers to the acronym itself. The GC framework is a substantial effort to merge parametric modeling functionalities from 3D solid modeling into the realm of architectural design. This is being done with the intention of delivering greater flexibility and ease of use in comparison to standard mechanical approaches to 3D solid modeling.

Users are able to interact with the software in a variety of ways, including dynamically modeling or physically altering geometry, setting rules and capturing interactions among model components, or constructing sophisticated structures and systems by using simply described algorithms. These are just some of the ways users can interact with the software. The software is compatible with a wide variety of file input and output formats that are typical in this sector, such as DGN by Bentley Systems, DWG by Autodesk, STL (Stereo Lithography), Rhino, and many more. In addition, the program is able to interface naturally and without friction with systems that are used for Building Information Modeling (BIM).

The application possesses an application programming interface (API) that is freely accessible to the public and uses an easy-to-understand scripting language. These features make it possible for the software to integrate without any problems with a wide variety of software tools and make it simpler for end users to create customized applications.

This software finds its primary application in the fields of architecture and engineering, more specifically in the process of designing buildings. On the other hand, it has also been put to use in the modeling of mathematical systems as well as natural and biological structures. Only the Microsoft Windows operating

system is supported by the Generative Components program because it was developed specifically for that platform.

Viktor:

Python is utilized to make the VIKTOR platform more user-friendly for the rapid development of online applications by software developers, engineers, and other subject matter experts. Utilization of this tool results in the generation of parametric design models. Additionally, this tool provides smooth connection with a wide variety of software applications. This piece of software makes it easier to create user interfaces (GUI) that include a wide variety of visual representations in an approachable fashion. Some of these representations include 3D models, drawings, maps or satellite views, and interactive graphs. This makes it possible for folks who do not have a strong predisposition toward programming to still have access to apps that can be downloaded.

Applications built with VIKTOR have an online character, which enables automatic data updates and ensures that all users are working with consistent and up-to-date information and models. Since these applications are online, they are produced with VIKTOR. A user management component has been built into the system, which gives administrators the ability to delegate differing degrees of access permissions to different individuals.

Modular:

modular is a piece of software that may be used to help with the many stages of the urban planning and design process. modular is a software plug-in for Trimble Sketch Up that specializes in the use of parametric design in urban planning and architecture. Agilicity d.o.o. (LLC) is the company that was responsible for developing it. The generation of conceptual urban massing is the major goal of this tool, and its primary purpose is to aid users in accomplishing that goal. In contrast to traditional computer-aided design (CAD) tools, which frequently include the design of buildings utilizing standard dimensions such as width, depth, and height, Modular presents a novel approach by enabling the design of the built environment based on essential urban factors, such as the number of storeys and the gross floor area of a building. This is in contrast to the common practice of designing buildings utilizing standard dimensions such as width, depth, and height.

modular has the capability of computing in real time essential urban control elements like the floor area ratio and the required number of parking spaces. During the construction process that is currently taking place, this program offers insights regarding urban design. In this approach, it makes the process of making

informed selections during the earliest phases, which are the phases in which design choices exert the most influence, easier.

Archimatix:

Archimatix is a piece of software that was developed with the intention of easing the process of creating and manipulating parameters. Archimatix is an extra piece of software for Unity 3D that takes a node-based approach to the process of creating parametric models. The Unity 3D editor makes it easier to create three-dimensional (3D) models using a visual modeling approach.

Grasshopper:

Grasshopper is going to be the key piece of software that is used for generative design and optimization of the particular case study that is being chosen for this thesis. As a result, an overview of Grasshopper's most important characteristics will be provided.

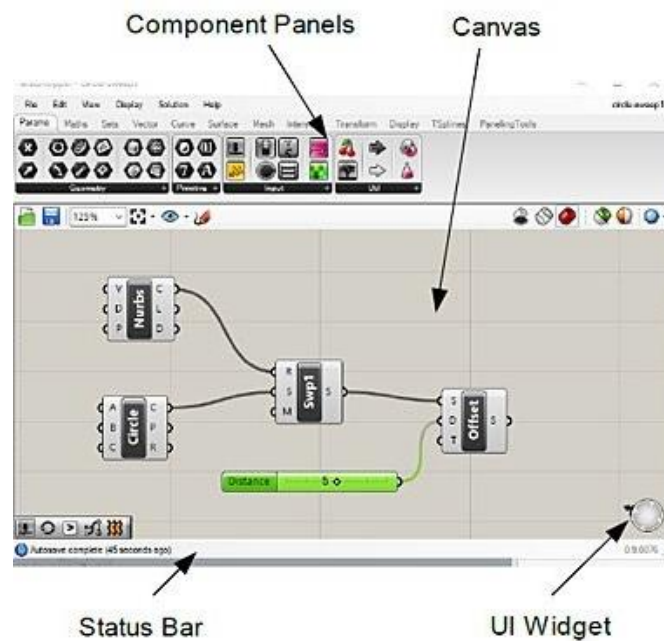

Figure 08 – The Grasshopper interface

Input and output node:

The sockets located on the left side of the node are specifically designed to receive inputs, providing a means for external information to be processed within the node itself. On the other hand, the sockets present on the right side of the node serve the purpose of facilitating the down streaming of outputs, allowing the processed information to be transmitted to subsequent stages or components in the system. This clear distinction between the left and right side sockets elucidates the specialized functions allocated to each side, enhancing the overall efficiency and effectiveness of the node in its role as a critical component of a complex network or system.

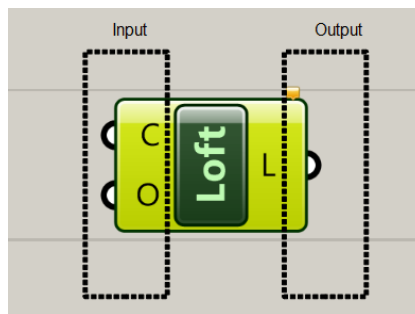

Figure 09 – The Grasshopper – Node

Colours of node and their corresponding meanings:

Orange means with warnings

Green means it is selected

Light Grey means no warning or errors

Darker grey means preview is disable

Greyed out means it has been disabled

Red means there is errors

Basic Operations:

There are 2 methods of adding components onto the canvas:

Method 1: Drag a new component onto the canvas.

Method 2: Double click on the canvas to bring up the keyword search box.

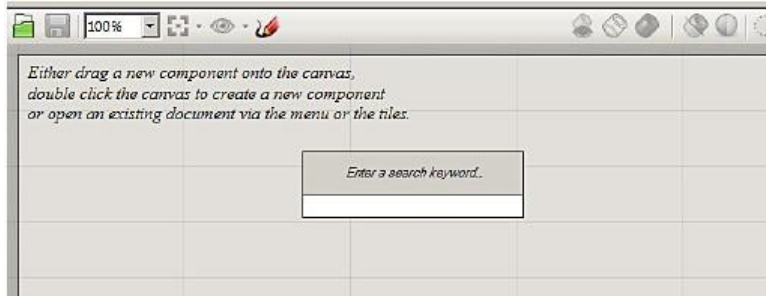

Figure 10 – The Grasshopper – Adding a component

To disconnect from a socket, right-mouse click, select Disconnect.

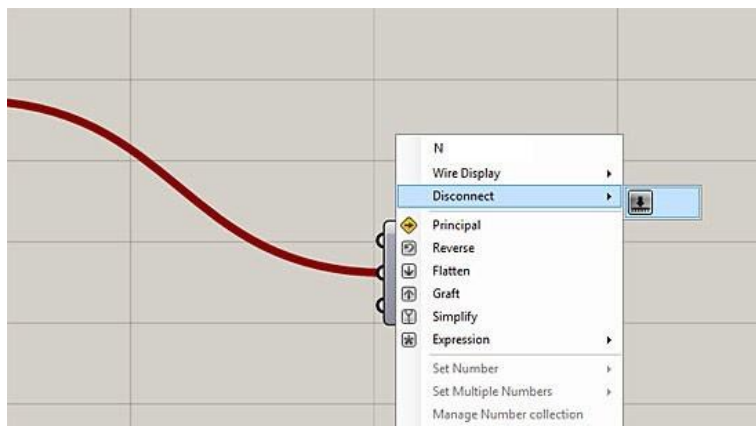

Figure 11 – The Grasshopper – Disconnect

To establish a connection with a socket that is already linked to an active connection, engage and maintain the SHIFT key.

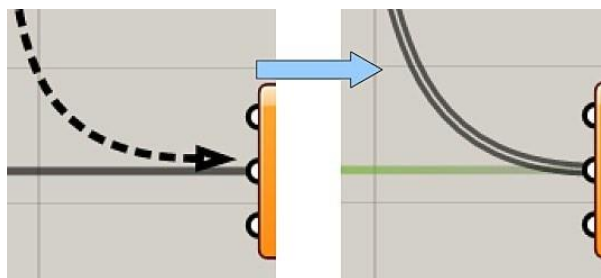

Figure 12 – The Grasshopper – Disconnect

Data Input methods:

Data input methods can generally be derived from the following sources:
data can be referenced from Rhino objects; values can be assigned for a component.

Grasshopper definitions can be saved:

Grasshopper definitions, which are algorithms in Grasshopper, can be saved by using the File > Save or File Save As commands.

There are two formats in which a Grasshopper definition can be saved:

gh format for Grasshopper binary and ghx format for Grasshopper XML.

Converting to Rhino surfaces – Bake surfaces:

To convert Grasshopper previews into editable geometry in Rhino, the bake command is used. To do this, the cursor is hovered over the desired component, right-clicked, and the Bake option is selected.

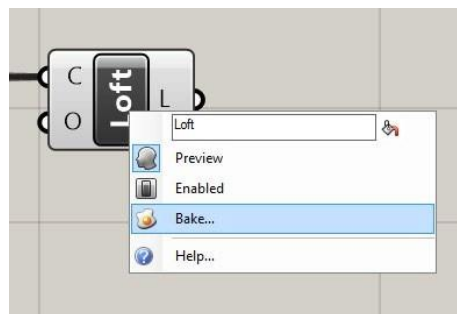

Figure 13 – The Grasshopper – Bake function

5.3. The Concept of Algorithm:

In the fields of mathematics and computer science, an algorithm is a finite sequence consisting of well-defined and computationally implementable instructions. These instructions are typically designed to address a specific set of problems or to carry out a particular computation. Algorithms possess the crucial characteristic of being unambiguous, allowing them to serve as precise specifications for performing calculations, processing data, engaging in automated reasoning, and undertaking various other tasks. Conversely, a heuristic is a problem-solving technique that relies on practical methods and/or estimations to generate solutions that may not be optimal but are nevertheless satisfactory given the given circumstances.

As a highly effective method, an algorithm can be articulated within a finite amount of space and time, expressed in a well-defined formal language specifically devised for the purpose of carrying out a function. Commencing from an initial state and initial input, which could be empty, the instructions provided facilitate a computation that, when executed, progresses through a finite number of well-defined successive states. Ultimately, this progression culminates in the production of an "output" and the termination of the process at a final ending state. It is important to note that the transition from one state to the next does not necessarily adhere to a deterministic pattern; certain algorithms, referred to as randomized algorithms, incorporate random input into their operations.

The notion of algorithm has been in existence since ancient times, dating back to antiquity. The ancient Babylonian mathematicians around 2500 BC and Egyptian mathematicians around 1550 BC employed arithmetic algorithms, such as the division algorithm, in their mathematical endeavors. Moving forward in history, Greek mathematicians in 240 BC utilized algorithms in the form of the sieve of Eratosthenes to facilitate the identification of prime numbers, as well as the Euclidean algorithm to determine the greatest common divisor of two numbers. Similarly, Arabic mathematicians like al-Kindi during the 9th century employed cryptographic algorithms for code-breaking, specifically drawing upon frequency analysis techniques.

The term "algorithm" itself finds its etymology in the name of the 9th-century mathematician Muḥammad ibn Mūsā al-Khwārizmī, whose association with Khwarazm is reflected in the Latinized form of his nisba as Algoritmi. The early stages of formalizing what would eventually evolve into the contemporary concept of algorithm can be traced back to early attempts at resolving the Entscheidungsproblem, or decision problem, propounded by David Hilbert in 1928. Subsequent formalizations aimed at defining the notion of "effective calculability" or "effective method." These formalizations encompassed various developments, such as the Gödel–Herbrand–Kleene recursive functions introduced in 1930, 1934, and 1935, Alonzo Church's lambda calculus of 1936, Emil Post's Formulation 1 of 1936, and Alan Turing's Turing machines of 1936–37 and 1939.

In Figure 22, one can observe the representation of a flowchart illustrating an algorithm, specifically Euclid's algorithm, which serves the purpose of calculating the greatest common divisor (g.c.d.) of two given numbers, denoted as a and b , situated in designated locations A and B. This algorithm

proceeds through a series of successive subtractions within two distinct loops. If the comparison test $B \geq A$ yields a positive result, namely "yes" or "true" (more accurately, when the number b located in position B is greater than or equal to the number a situated in position A), the algorithm directs the replacement of B with the result of $B - A$. Analogously, if A is greater than B , then A is replaced by $A - B$. The termination of this process is achieved when the contents of B reach a value of 0, thereby resulting in the computation of the g.c.d. stored in A . It is worth noting that this algorithm is derived from Scott (2009) on page 13, and the symbols and drawing style employed in the representation are influenced by Tausworthe (1977).

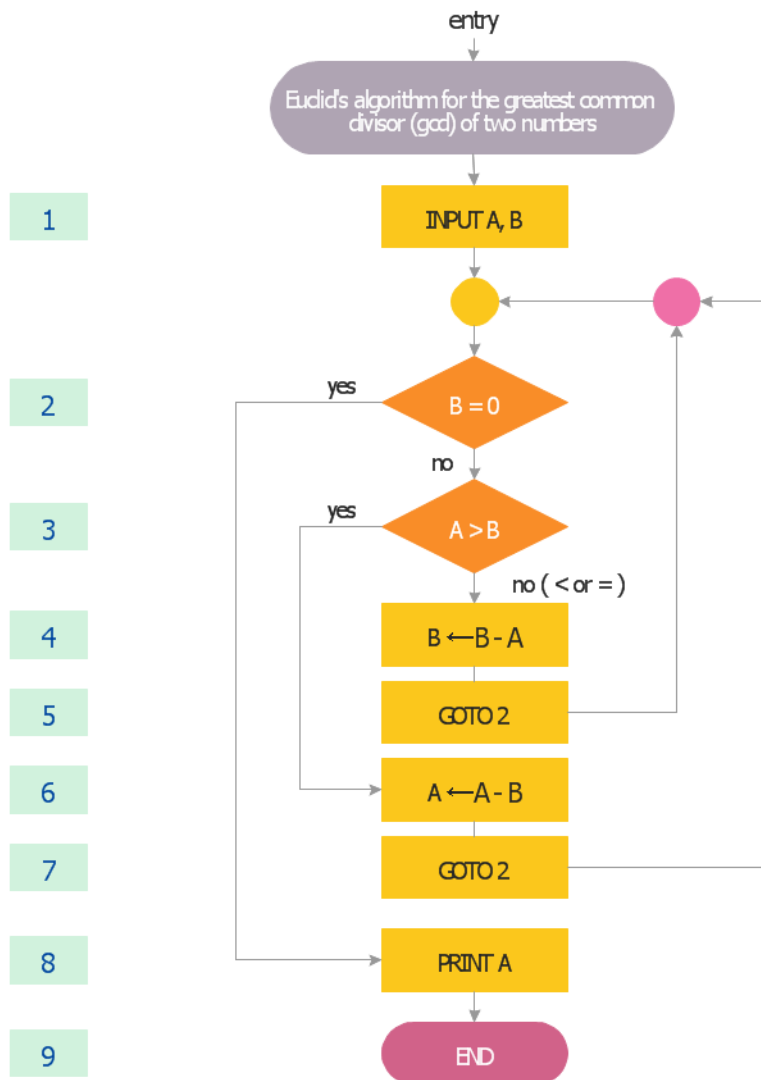

Figure 14 – Euclid's Algorithms

5.3.1. The Nature of the Generative Design:

If we take a closer look at architecture from the perspective of an object that is represented in space, we can observe that it always involves the use of geometry and a certain level of mathematical understanding to comprehend and design this object. Throughout the history of architecture, various architectural styles have presented diverse types of geometry and logic of articulation, and each period has found its own unique approach to addressing the geometrical challenges and questions that arise. With the advent of computers and their assistance to architects in simulating space and geometrical articulations, computational geometry has emerged as a captivating subject of study. The combination of programming algorithms with geometry has given rise to algorithmic geometries, which are commonly referred to as Generative Algorithms. While 3D software has greatly facilitated the visualization of almost any imaginable space, it is the concept of Generative Algorithms that has truly expanded the realm of architectural design by introducing possibilities such as "parametric design". Architects have begun utilizing free-form curves and surfaces as tools for designing and exploring spaces that go beyond the constraints of traditional Euclidean geometries. It is the combination of architecture and digital technology that has brought about the emergence and advancement of the concept of "Blobs". Despite the rapid progress in computational capabilities, architecture has made efforts to keep up with the fast-paced digital advancements. In the contemporary era of architecture, following the age of "Blobs", there is a noticeable emphasis on precision and meticulousness in dealing with these subjects. Architectural design is now being influenced by the potential of algorithmic computational geometries, which involve multiple hierarchies and a high level of complexity. Designing and modeling free-form surfaces and curves as building components, which are intricately associated with different elements and exhibit various patterns, is no longer a simple task that can be accomplished using traditional methods. This is where the power of algorithms and scripts comes into play, as they push the boundaries forward. It is evident that even the mere contemplation of a complex geometry necessitates the use of appropriate tools, particularly software applications that are capable of simulating these geometries and controlling their properties. As a result, architects have shown a keen interest in utilizing techniques such as Swarms, Cellular Automata, and Genetic Algorithms to generate algorithmic designs and surpass the existing palette of available forms and spaces. The horizon of architectural possibilities is now an extensive

catalogue of complexity and multiplicity, in which creativity and ambition converge harmoniously.

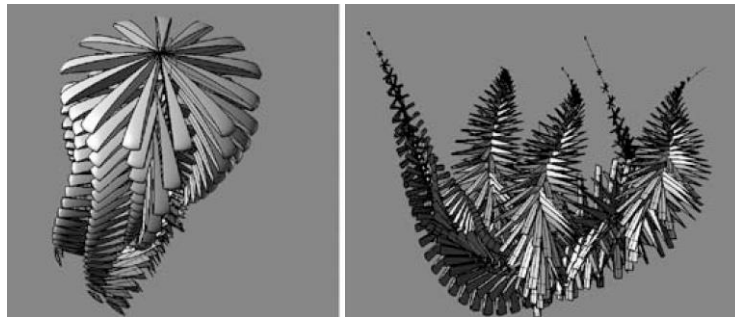

Figure 15 – Parametric Modelling for Evolutionary Computation and Genetic Algorithm

(Zubin Mohamad khabazi, Emergence Seminar, AA, conducted by Michael Weinstock, fall 2008)

A step forward in the field of design algorithms is the possibility of embedding the properties of material systems. This parametric notion allows for a closer examination of how materials interact with their environment during the design phase. By incorporating the inherent potentials of components and systems into parametric models, these generative algorithms can not only generate forms but also integrate the logic of material systems.

The parametric design approach can be seen as an alternative method that utilizes the geometric rigor of parametric modeling to integrate manufacturing constraints, assembly logics, and material characteristics. This approach starts by defining simple components that take into account these constraints and characteristics. These components are then proliferated into larger systems and assemblies. This exploration of parametric variables allows for a better understanding of how the system behaves, which can then be used to strategize the system's response to environmental conditions and external forces.

To work with complex objects, the design process typically starts with a simple first level and gradually adds layers of complexity. These complex forms are composed of different hierarchies, each with its own logic and details. The levels are interconnected, and changes in one element can affect others. This method, known as "Associative Modeling," involves building the design gradually in multiple hierarchies, with parameters of each element extracted to generate other elements in the next level. This iterative process continues until the entire

geometry is produced. For example, the endpoint of one curve can be the center point of another circle, and any changes to the curve will accordingly affect the circle.

The advantage of this method is that all geometries are easily adjustable even after the design process. Designers have access to the elements of the design product from the start point to the smallest details. Since the design product is the result of an algorithm, the inputs can be changed, and the result will be updated accordingly. This allows for the

digital sketching of models and the generation of numerous variations by adjusting basic geometrical parameters. Additionally, the properties of material systems, fabrication constraints, and assembly logics can be embedded in the parameters. This approach also enables a responsive design that can adapt to the environment and maintains an associative relationship between elements.

Overall, parametric design allows for the recognition of patterns of geometric behavior and the understanding of the performative capacities and tendencies of the system. Through continuous feedback with the external environment, these behavioral tendencies inform the ontogenetic development of the system through parametric differentiation of its sub-locations. The design process involves a significant amount of data and calculations, which are facilitated by the flow of algorithms.

A sample of Computational approach for form-finding optimal design:

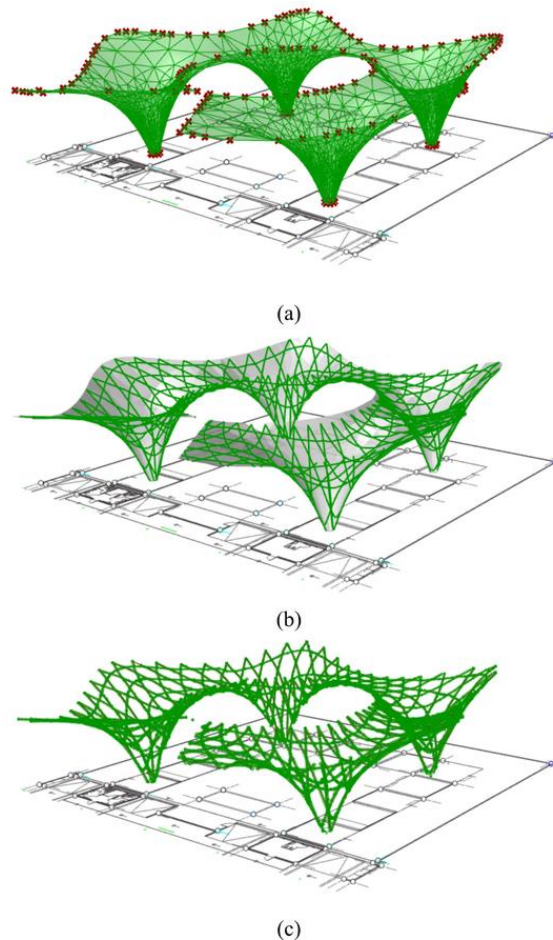

Figure 16 – Formation of grid shell through surface relaxation, a Mesh creation from anchorage points, b Kagome grid pattern projection on mesh, c Final grid shell.

The Grasshopper platform, which is a part of Rhino, serves as a tool that facilitates the manipulation and management of Generative Algorithms and Associative modelling techniques. The subsequent chapter that follows is meticulously crafted with the intention of seamlessly merging geometrical concepts with algorithms, all in an endeavor to tackle various design predicaments within the realm of architecture, utilizing a method that is described as 'Algorithmic'. The underlying objective of this approach is to expand the scope and breadth of geometrical subjects, thereby enabling the incorporation of a wider array of commands and examples that are specifically tailored to achieve this end goal.

5.3.2. Introduction to Genetic Algorithms:

The inspiration for the Genetic Algorithm (GA) stems from the Darwinian theory of evolution, wherein the survival of the fittest creatures and their genes is simulated. GA, being a population-based algorithm, operates by assigning each solution a chromosome, with each parameter representing a gene. To evaluate the fitness of each individual within the population, GA employs a fitness (objective) function. In order to enhance subpar solutions, the best solutions are randomly selected using a selection mechanism such as a roulette wheel. The use of this operator significantly increases the likelihood of choosing the best solutions, as the probability of selection is directly proportional to their fitness (objective value). Importantly, the probability of selecting poor solutions is also increased, thereby aiding in the avoidance of local optima. Therefore, even if good solutions become trapped within a local solution, they can be rescued by other solutions.

The stochastic nature of the GA algorithm may lead one to question its reliability. However, the algorithm's reliability and ability to estimate the global optimum for a given problem lies in its process of maintaining the best solutions in each generation and utilizing them to enhance other solutions. Consequently, the overall population progressively improves from generation to generation. The crossover between individuals facilitates the exploitation of the "area" between the two parent solutions. Furthermore, GA benefits from the inclusion of the mutation operator, which randomly alters the genes in the chromosomes. This serves to preserve the diversity of individuals within the population and enhances the exploratory behavior of GA. Similar to nature, the mutation operator has the potential to yield substantially improved solutions and guide other solutions towards the global optimum.

initial population: The initial population within the GA algorithm commences with a randomly generated set of individuals. This population is derived from a Gaussian random distribution, which serves to enhance the diversity within the population. It is important to note that this population consists of multiple solutions, each of which represents the chromosomes of the individuals. These chromosomes are characterized by a set of variables that simulate the genes. The primary objective during the initialization step is to disperse the solutions uniformly across the search space, thereby maximizing the diversity within the population. By achieving this, there is an increased likelihood of discovering promising regions. The subsequent sections delve into the steps that are implemented to enhance the chromosomes within the initial population.

The selection: The selection component of the GA algorithm draws inspiration from natural selection. In nature, the individuals that are most fit have a greater probability of obtaining food and successfully reproducing. Consequently, their genes play a more significant role in the production of the subsequent generation of the same species. Building upon this fundamental concept, the GA algorithm utilizes a roulette wheel mechanism to allocate probabilities to the individuals and select them for the purpose of generating the next generation. The selection process is proportionate to their respective fitness values. To illustrate, Figure 25 provides an example of a roulette wheel for a group of six individuals. The specific details pertaining to these individuals are presented in Table 1.

Individual number	Fitness value	% of Total
1	12	5
2	55	24
3	20	8
4	10	4
5	70	30
6	60	26
Total	227	100

Table 1– Details of the individuals in Fig 17 The fittest individual is Individual #5

It can be observed that the individual with the highest ranking, denoted as #5, possesses the largest proportion of the roulette wheel. Conversely, the individual with the lowest ranking, denoted as #4, possesses the smallest proportion. This mechanism effectively emulates the process of natural selection, where the most fit individual is favored. The roulette wheel, being a stochastic operator, introduces an element of chance, thereby reducing the likelihood of poor individuals contributing to the creation of the next generation. However, in the event that a poor solution fortuitously succeeds, its genetic material is carried forward into subsequent generations. The elimination of such solutions would result in a reduction in the overall diversity of the population, a consequence that should be avoided.

It is important to emphasize that the roulette wheel, which is a mechanism employed in the literature, constitutes one of the numerous selection operators implemented in the field. Additionally, there exist various other selection operators that are utilized for the same purpose:

- Boltzmann selection
- Tournament selection
- Rank selection
- Steady state selection
- Fuzzy selection
- Fitness uniform selection
- Proportional selection
- Linear rank selection
- Steady-state reproduction
- Truncation selection
- Local selection

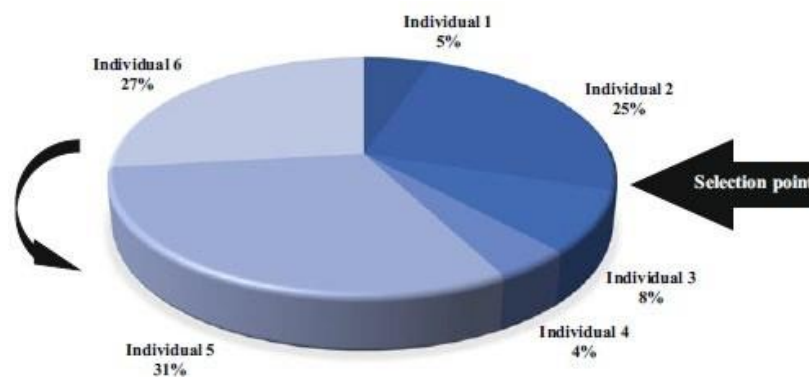

Figure 17– Mechanism of the roulette wheel in GA. The best individual (#5) has the largest share of the roulette wheel, while the worst individual (#4) has the lowest share

Crossover (Recombination): After the individuals have been selected through a selection operator, they must be employed in order to generate the new generation. This process is akin to the natural combination of chromosomes in the genes of a male and a female, which results in the creation of a new chromosome. In the context of the GA algorithm, this simulation is achieved by merging two solutions, specifically parent solutions, that have been chosen using the roulette wheel mechanism. As a result of this combination, two new solutions,

known as children solutions, are produced. The literature offers various techniques for the crossover operator, two of which, namely single-point and double-point approaches, are illustrated in Figure 18.

In the single-point cross over phenomenon, the chromosomes originating from the two parent solutions undergo a process of interchange, where they are swapped, both before and after a singular point. On the other hand, in the double-point crossover methodology, there are two distinct cross over points established, leading to the swapping of the chromosomes located solely between these two designated points.

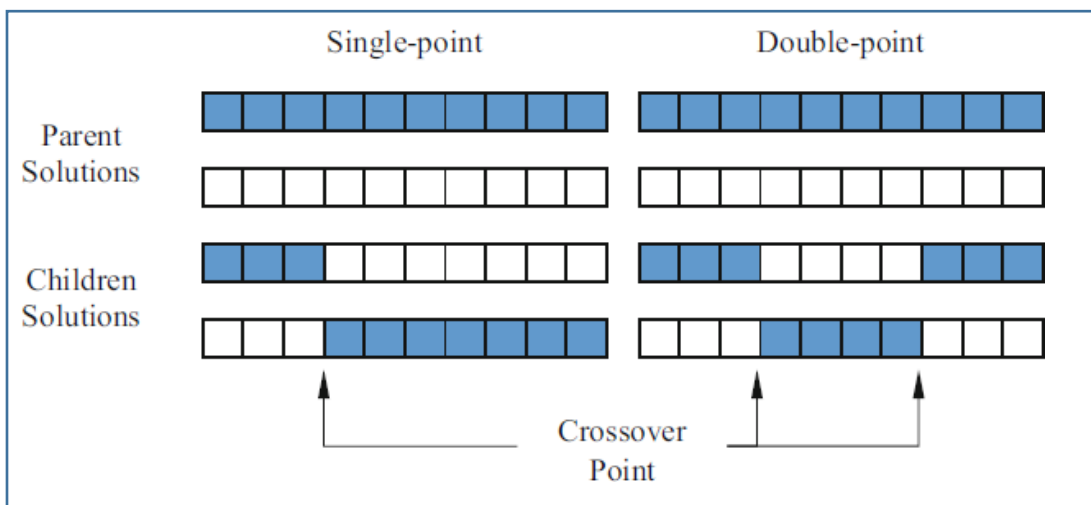

Figure 18– Two popular crossover techniques in GA: single-point and double point.

Other crossover techniques in the literature are:

- Uniform crossover
- Order crossover
- Position-based crossover
- Heuristic cross over
- Masked crossover
- Multi-point crossover
- Half uniform crossover

- Three parent's crossover
- Partially matched crossover
- Cycle crossover

The Mutation: the final evolutionary operator, which involves modifying one or more genes subsequent to the creation of offspring solutions, is known as mutation. In order to prevent the degradation of genetic algorithms (GA) into a rudimentary random search, it is essential to maintain a low mutation rate. By introducing an additional level of randomness, the mutation operator serves to uphold the diversity of the population. This operator effectively inhibits solutions from becoming too similar, thereby increasing the likelihood of avoiding local solutions within the GA algorithm. To further illustrate this concept, Figure 18 provides a visual representation of the mutation operator. Within this figure, it is evident that minor alterations occur in certain randomly selected genes following the crossover (recombination) phase.

Some of the popular mutation techniques in the literature are:

- Power mutation
- Uniform
- Non-uniform
- Gaussian
- Shrink
- Supervised mutation
- Uniqueness mutation
- Varying probability of mutation

Taken as a whole, the majority of Evolutionary Algorithms (EAs) employ three essential evolutionary operators, namely selection, crossover, and mutation. These operators are systematically applied to each subsequent generation with the objective of enhancing the quality of genes in the subsequent generation. Elitism, which involves the preservation and transfer of one or multiple best solutions without any modification to the next generation, is another widely

utilized evolutionary operator. The primary aim of employing elitism is to prevent the degradation of such elite solutions when subjected to the crossover or mutation operators.

The Genetic Algorithm (GA) initiates its execution with a random population of individuals. Throughout the execution, until the specified termination criterion is met, this algorithm diligently improves the population by employing the aforementioned three operators. Ultimately, the best solution present in the last population is returned as the most accurate approximation of the global optimum for a given problem. It is worth noting that the rates at which the selection, crossover, and mutation operations are applied can be adjusted or fixed to specific values during the optimization process.

5.4. Topology and Form Finding:

The subsequent section describes the optimization problem for the geodesic dome was effectively executed directly within the Rhinoceros Grasshopper platform utilizing the Galapagos tool. In order to conduct comprehensive structural analyses, the Alpaca4D plug-in was employed, taking into consideration both the ultimate limit state (ULS) and the serviceability limit state (SLS) conditions.

Subsequently, the outcome of these meticulous structural analyses was meticulously gathered and processed through the utilization of a Python script, which was skillfully implemented in the Python plug-in of Grasshopper. The primary purpose of this script was to accurately ascertain the objective function, namely the volume, while simultaneously evaluating the penalized volume in order to assess the feasibility of the constraints and any potential violations. The Galapagos plug-in was thus seamlessly integrated with the Python script component output, specifically with respect to the penalized objective function, as it serves the pivotal role of an unconstrained optimizer tool. To ensure optimal performance, an evolutionary solver was employed, employing a population size consisting of 50 individuals. Given that the search space topology is intricately linked to the dome's frequency, the frequency of the geodesic was skillfully parametrized.

The goal of this study is on optimizing geodesic domes by making the frame structure and connections as small as possible. During the optimization process,

the base radius of the dome is thought to stay the same. This is called a shape constraint. The change in frequency makes it possible to change the number of frames, which changes the structure's topology while changing the shape of the parts (shape optimization). In the case study, the effects of self-weight and asymmetric load movements are looked at, along with how to build a geodesic dome. In the optimization step, the results of a Finite Element Analysis (FEA) are used by evolutionary genetic algorithms (EAs).

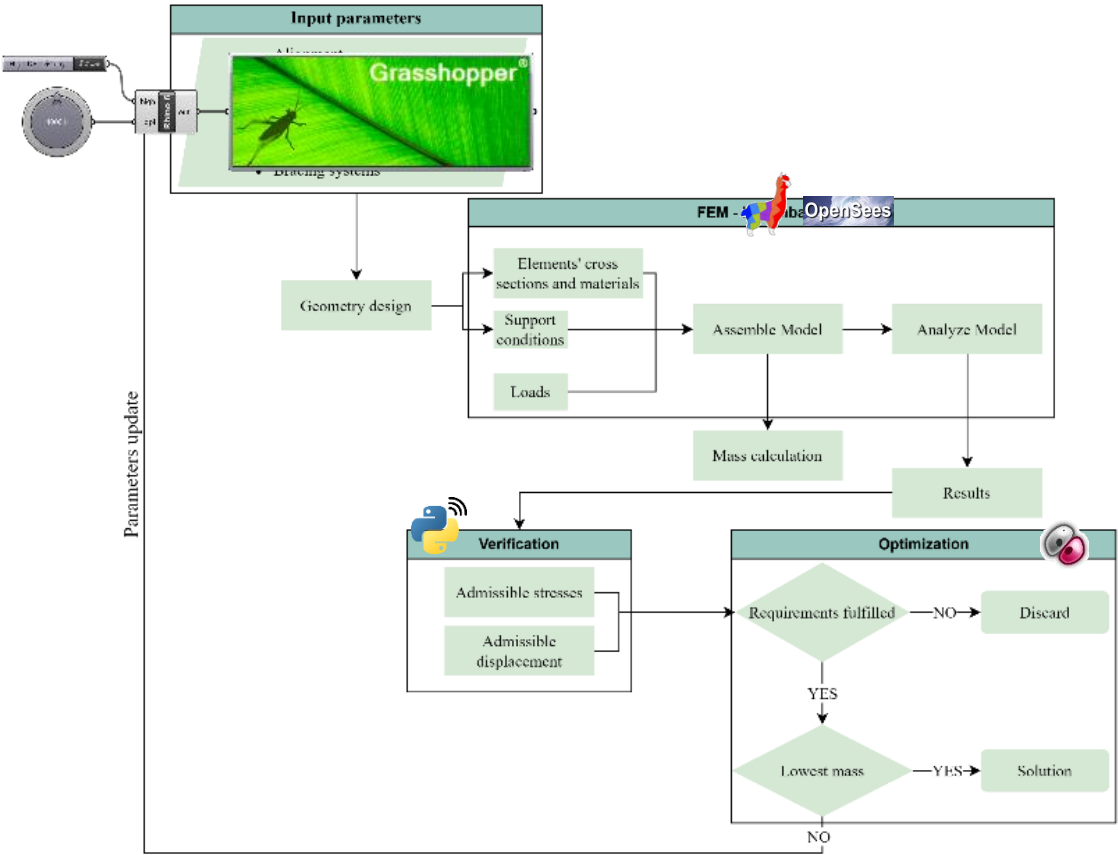

Figure 19 – the flowchart of geodesic dome optimization process

5.4.1. Grasshopper and Karamba:

Grasshopper and Karamba are two integral components within the Rhino3D environment. Grasshopper, a visual coding environment, employs pre-coded components that are placed on a canvas and interact with the Rhino modeling space. Unlike traditional code writing, Grasshopper operates in a unique manner as there is no need to "run" the code. Instead, all components are continuously running, enabling any modifications to be instantly seen in real time within Rhino.

Karamba, an exceptionally resilient plugin, offers an array of advanced capabilities for structural analysis, empowering users to assess the load-bearing capacity, structural soundness, and stress distribution of various architectural designs. On the other hand, is a structural analysis plugin specifically designed for Grasshopper. It possesses the capability to perform numerous tasks that are typically executed by traditional analysis programs. The predominant advantage of Karamba lies in its ability to identify and generate more optimal forms as well as determine the optimal placement of materials.

5.4.2. The Galapagos:

The Galapagos plugin, an integral component of the Grasshopper platform, serves as a facilitator for the intricate process of structural optimization, allowing for a systematic exploration and discernment of the most advantageous design alternatives based on predetermined criteria.

5.4.3. The Pufferfish:

The Pufferfish software, a remarkable and revolutionary technological marvel, provides a plethora of cutting-edge tools that are specifically tailored to cater to the intricate and multifaceted needs of geometric and structural manipulation. This state-of-the-art software effortlessly facilitates the efficient modeling and study of intricate dome shapes, enabling architects and designers to delve deep into the complexities of these awe-inspiring structures with unparalleled ease and precision. By seamlessly integrating advanced geometric and structural manipulation tools, the Pufferfish software empowers designers to explore and experiment with a wide range of intricate dome shapes, allowing for the creation of stunning and visually captivating architectural masterpieces.

5.4.4. Kangaroo:

Kangaroo, a truly groundbreaking and innovative Grasshopper plugin, harnesses the power of physics-based simulation to revolutionize the field of structural analysis. With its unparalleled capabilities, this remarkable plugin enables architects and designers to instantly evaluate the dynamics and efficacy of geodesic dome constructions. By employing sophisticated physics-based algorithms, Kangaroo effortlessly simulates the behavior and response of dome structures under various conditions, providing architects and designers with invaluable insights into their structural integrity and performance. This transformative technology not only saves significant time and resources but also allows for the exploration of new and unconventional design possibilities, pushing the boundaries of architectural innovation to new heights.

5.4.5. Finite Element Analysis:

The computational technique known as Finite Element Analysis (FEA), which is utilized to evaluate and resolve engineering problems, is a widely recognized method in the field. FEA employs a numerical approach to analyze intricate structures and systems, enabling engineers to gain a comprehensive understanding of their response to various loading scenarios. This method involves breaking down complex structures into discrete components or meshes, which are finite in size. These components, commonly referred to as elements, are interconnected at different locations known as nodes, forming a mesh network. By applying mathematical equations, FEA allows for the analysis of a structure's behavior, taking into consideration crucial factors such as material properties, shape, and applied loads.

To provide a more comprehensive understanding of the Finite Element Analysis (FEA) technique, it is essential to delve into its step-by-step procedure:

The first stage, known as preprocessing, involves the creation of a digital representation of the structure. This digital representation serves to establish the geometric qualities, material properties, and boundary conditions of the structure under analysis. The structure is then divided into discrete finite elements, with each element being assigned a unique node. This process, known as discretization, entails breaking down the continuous structure into smaller pieces, typically triangles or quadrilaterals in two dimensions, or tetrahedrons or

hexahedrons in three dimensions. Each individual element possesses unique properties, such as stiffness and mass, which are determined by the material composition and geometric qualities of the structure.

The behavior of each individual element is characterized by the utilization of mathematical equations, which are based on mechanical principles. These equations include equilibrium equations, compatibility requirements, and constitutive equations, all of which establish the relationship between stress and strain within the structure. Furthermore, the constituent equations of each element are assembled to create a comprehensive system of equations that accurately depict the behavior of the overall structure. This process, known as assembly, takes into account the interactions between elements through shared nodes.

Once the system of equations is assembled, numerical techniques are employed to solve the equations and calculate key outputs such as displacements, stresses, and strains. The solution obtained through this process provides vital insights into the structural response, including deformations, stresses, and predicted failure locations. The collected data from the analysis is then displayed and analyzed to provide a thorough understanding of the structural reaction. This analysis may involve the creation of contour plots, stress distribution graphs, displacement animations, and various other visual representations, all of which contribute to a comprehensive understanding of the structural behavior.

The application of Finite Element Analysis (FEA) extends beyond its use as a computational method for engineering problem-solving. It is widely employed in the fields of engineering and design to examine the structural robustness, operational efficiency, and overall safety of various structures. These structures can range from buildings and bridges to mechanical components and geodesic domes. By utilizing FEA, engineers are able to optimize designs, identify potential failure points, and make informed decisions to enhance structural performance and efficiency. It is a powerful tool that plays a crucial role in ensuring the safety and effectiveness of various engineering projects.

In conclusion, Finite Element Analysis (FEA) is a computational method used to assess and solve engineering problems. It involves the breaking down of complex structures into discrete finite elements, which are interconnected at nodes to form a mesh network. Through the utilization of mathematical

equations, FEA allows for the analysis of a structure's behavior, considering factors such as material properties, shape, and applied loads. The step-by-step procedure of FEA encompasses preprocessing, discretization, characterization of element behavior, assembly of equations, numerical solution, and analysis of results. This technique is widely employed in engineering and design to evaluate structural robustness, operational efficiency, and overall safety. By utilizing FEA, engineers can optimize designs, identify potential failure points, and make informed decisions to enhance structural performance and efficiency. Studying the functionality of the dome enables us to gain a comprehensive understanding of its operational mechanisms, thereby facilitating the accurate prediction of its response to external influences and ensuring its optimal safety and performance.

5.4.6. Evolutionary Genetic Algorithms:

Evolutionary Genetic Algorithms (EAs), which are a type of optimization method, are rooted in the natural phenomenon of how things evolve and change over time. These algorithms leverage the principles of genetics and evolution to effectively find the most optimal solution to a problem by iteratively exploring various possibilities. When applied in conjunction with the Finite Element Method (FEM) research, EAs can significantly enhance the design of geodesic domes.

The process of using EAs with FEM analysis to improve geodesic domes can be comprehensively outlined as follows:

Firstly, the optimization problem is clearly defined, along with the specific goal function that needs to be either minimized or maximized. In the context of geodesic domes, this goal function could encompass objectives such as minimizing material usage, maximizing structural stability, or optimizing any other performance metric deemed relevant.

Next, the design factors of the geodesic dome, such as node coordinates, member lengths, or connection parameters, need to be encoded into a chromosome representation. A chromosome essentially represents a set of genes, which in turn corresponds to a potential solution to the optimization problem at hand.

Following the encoding stage, a random set of chromosomes is generated as an initial starting point. Each chromosome represents a distinct plan or solution for the geodesic dome, ensuring diversity in the initial population.

Subsequently, FEM analysis is conducted on the design of each geodesic dome represented by the chromosomes within the population. The FEM analysis serves to assess the performance and suitability of each design with respect to the predefined goal function.

In the selection stage, chromosomes that exhibit higher fitness values are chosen to form the next generation. Fitness values are indicative of the quality of an answer, with higher values implying superior performance. Various selection methods, such as championship selection or roulette wheel selection, are commonly employed in EAs to determine which chromosomes are more likely to be selected for reproduction.

Variation operators, namely crossover and mutation, are then applied to the selected chromosomes in order to generate offspring for the subsequent generation. Crossover involves combining genetic information from two parent chromosomes, while mutation introduces random changes to one or more chromosomes. These operators mimic the process of genetic recombination and variation, simulating the natural evolution of genes over time.

The offspring, along with some of the parent chromosomes, undergo evaluation and selection through FEM analysis to determine their fitness. This process enables the identification of the most promising candidates for the next generation.

The iterative nature of the EA continues until a predetermined criterion for ending the process is reached. This criterion could be defined by factors such as a maximum number of generations, reaching a certain level of fitness, or adhering to specific computational constraints.

Finally, once the EA has completed its iterations, the best solution or a set of promising solutions are extracted from the final population. These solutions represent the most optimal designs for the geodesic dome that align with the predefined goal function.

In conclusion, Evolutionary Genetic Algorithms, when coupled with FEM analysis, provide a robust methodology for enhancing the design of geodesic domes. Through a systematic process involving encoding, initialization, evaluation, selection, variation operators, and solution extraction, these algorithms enable the identification of optimal solutions that meet the defined goal function.

By incorporating Finite Element Method (FEM) analysis into Evolutionary Algorithms (EAs), the process of optimization can effectively and rapidly investigate the vast design space of geodesic domes, thus facilitating the discovery of optimal combinations. EAs possess the remarkable characteristic of continuity, which enables them to consider a multitude of diverse design factors and intricate interactions. Consequently, this attribute of EAs contributes to the attainment of enhanced structural performance and efficiency when it comes to the design of geodesic domes. Through the integration of FEM analysis with EAs, designers are empowered to thoroughly explore the potential of various design alternatives, enabling them to identify and select the most favorable options for achieving optimized geodesic dome structures.

5.4.7. Alpaca4D- structural analysis tool:

Alpaca4D is a structural analysis tool designed as a plugin for Grasshopper, developed on top of OpenSees. It allows for the analysis of beam, shell, and brick elements through various analysis methods including static, modal, and ground motion analysis. This tool is developed by Marco Pellegrino and was previously helped by Domenico Gaudio. Alpaca4D is particularly useful in modeling complex geometries within a parametric workflow, significantly reducing the time spent in modeling. It's designed to provide an efficient and easy way to use OpenSees without needing to write any code. However, it's mostly used by researchers and academia due to its sophisticated mathematical core and a less user-friendly interface.

Types of Analyses in Alpaca4D:

Linear Static Analysis: Determines the static response of a structure to known loads, showing deflection, stress, and strain.

Linear Dynamic Analysis: Studies dynamic response to loads like earthquakes or wind, calculating response spectrum, mode shapes, and frequencies.

Nonlinear Static Analysis: Used for investigating structures under large deformations, often for extreme conditions like collapse or failure.

Nonlinear Dynamic Analysis: Combines principles of linear and nonlinear static analysis for structures under dynamic loads causing large deformations.

Pushover Analysis: Determines the nonlinear static response to a monotonic lateral load, commonly used for assessing seismic performance.

5.4.8. Python scripting in grasshopper:

Python scripting in Grasshopper (GH) is facilitated by the GhPython component, which integrates scripting components as a part of Grasshopper. These components can interact with other standard GH components, enabling the creation of specialized functionality.

GhPython Component: Supports rhinoscriptsyntax functions to generate geometry inside Grasshopper that doesn't exist in the Rhino document. This is achieved through "duck typing," which swaps the document target of rhinoscriptsyntax functions from Rhino to Grasshopper. For example, a script that adds points to the Rhino document can also add points to a Grasshopper document when run inside a GhPython component.

Support for Multiple Languages: Grasshopper supports multiple .NET scripting languages like VB and C#, along with Python. Python, known for its versatility, is used for a wide range of programming contexts beyond just scripting.

SDKs for Python: Rhino provides SDKs (software development kits) for scripting in Python. RhinoScriptSyntax is the basic SDK, while more experienced programmers might use the Rhino Common SDK for more direct access to Rhino functions.

Setting Up Python Scripting: To start with Python scripting, add the Python script component to the Grasshopper canvas from the "Script" panel under the "Maths" tab.

The default script component has two inputs and two outputs, which can be customized in terms of names, data types, and structures. Users can also add or remove input and output parameters as needed.

A Simple Example: For a basic "Hello World!" script, drag a Python component onto the Grasshopper canvas, connect a Boolean component to the x input, and a Panel component to an output. The script checks for a TRUE in `x` to display the message through the 'a' output.

These guides provide a foundational understanding of how Alpaca4D and Python scripting work in Grasshopper, enabling users to start exploring these powerful tools for structural analysis and scripting in architectural and design workflows.

Pushover Analysis: Determines the nonlinear static response to a monotonic lateral load, commonly used for assessing seismic performance.

6. some example of Geodesic Domes:

Since the first development of **Richard Buckminster Fuller's** prototype for the **geodesic dome**, a significant number of geodesic domes have been constructed across the globe. The following examples are noteworthy:

6.1. The Dome at Biosphere 2 (Arizona, USA):

The focal point of Biosphere 2, a research facility dedicated to experimental investigations, is the expansive geodesic dome situated in Arizona, USA. The dome encompasses a range of ecosystems, such as a rainforest, ocean, and savannah, thereby establishing a meticulously regulated environment conducive to scientific investigations.



Figure 20 –The Dome at Biosphere 2

With dimensions equivalent to almost two and a half football fields, it stands as the most extensive enclosed system ever constructed. The glass facility is situated at an elevation of approximately 4,000 feet above sea level, located at the foothills of the Santa Catalina Mountains. The user did not provide any text to rewrite. The hermetically sealed characteristics of the construction facilitated the scientific observation of the dynamic chemical composition of the enclosed air, water, and soil.

The structural composition of the above-ground portion of Biosphere 2 consisted of steel tubing and high-performance glass and steel frames. The frame and

glass materials were specifically designed and manufactured by Pearce Structures, Inc., a company founded by Peter Pearce, who had previously collaborated with Buckminster Fuller. The design of the window seals and structures necessitated a high degree of airtightness to minimize air exchange, so mitigating potential harm to the integrity of the experimental outcomes.

The architectural design was noteworthy due to its effective management of atmospheric expansion. Throughout the diurnal cycle, the thermal energy emitted by the sun engendered a phenomenon whereby the air within the system underwent expansion, while during the nocturnal period, the air experienced a cooling effect, leading to contraction. In order to mitigate the substantial stresses associated with keeping a constant volume, the construction had sizable diaphragms housed within structures referred to as "lungs".

Due to the impracticability of opening a window, the architectural design necessitated the installation of large-scale air conditioning systems to regulate the temperature and prevent harm to the enclosed vegetation. The air conditioning systems in the structure consumed nearly three times the amount of energy required to chill the habitat for each unit of solar energy that entered.

6.2. Eden Project (Cornwall, UK):

The Eden Project, located in Cornwall, UK, is widely recognized as a prestigious botanical garden and a center for environmental education. The structure comprises a collection of geodesic domes referred to as "biomes," each accommodating distinct climatic zones, hence exhibiting a diverse array of plant species from globally.



Figure 21 –Eden Project (Cornwall, UK)



Figure 22 – Eden Project (Cornwall, UK)

The awe-inspiring spectacle of dome-shaped Biomes nestled within a reclaimed clay quarry has attracted a multitude of tourists from various corners of the globe. The Eden site encompasses various instances of distinctive and environmentally conscious architectural designs, such as the Core building, which draws inspiration from botanical elements. The design idea is inspired by nature and they are kind of Low-energy buildings. The Rainforest Biome and the

Mediterranean Biome, both of which were designed by Grimshaw Architects, are comprised of multiple interconnected domes. These two Biome buildings are connected at their center by the Link building.

The design and material selection:

The clay pit was still mined when the Biomes were designed. Grimshaw suggested soap bubbles since this environment is always changing. Remember making bubbles as a kid? These creatures can adapt to different surfaces. In addition, when two or more bubbles fuse, the line of fusion always aligns vertically. The pit's uneven and fluctuating sands made soap bubbles a suitable base for building the 'lean-to' Biome constructions.

Each dome has a two-level hex-tri-hex space frame. The exterior is covered in hexagons, with the largest reaching 11 meters in diameter, and pentagons. The inner layer has tightly fastened hexagons and triangles. The steel framework weighs slightly more than Biome air. Constructions are more likely to be moved upwards than downwards. Thus, earth anchors, like tent pegs, hold them to the foundations.

The hexagonal and pentagonal translucent panels are made of ETFE, a "cling film with attitude." Three layers of an amazing material are inflated to produce a two-meter pillow-like structure in each window. ETFE windows, which make up less than 1% of glass, can support an automobile despite their small weight. ETFE transmits UV light and is non-stick and self-cleaning.



Figure 23– early sketches of biome structural elements on napkins

6.3. Montreal Biosphere (Quebec, Canada):

The Montreal Biosphere, located in Quebec, Canada, was initially constructed as the United States pavilion for Expo 67. Presently, it serves as an environmental museum. The geodesic dome structure, renowned for its iconic status, has emerged as a prominent emblem of the city, serving as a venue for exhibitions and educational events.

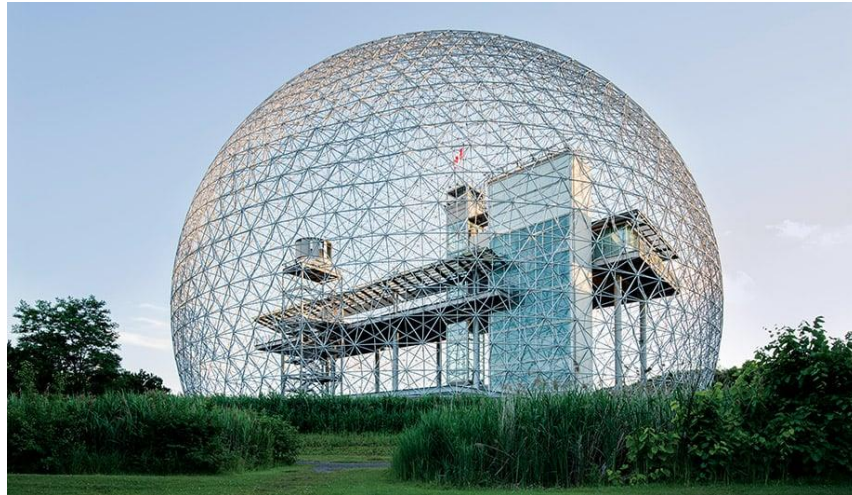

Figure 24 – the Montreal Biosphere (Quebec, Canada)

6.4. Epcot Center's Spaceship Earth (Florida, USA):

The focal point of the Epcot theme park in Walt Disney World Resort is Spaceship Earth, a geodesic dome construction situated in Florida, USA. The dome encompasses a dark ride that guides tourists on a journey exploring the historical and prospective aspects of communication. The geodesic sphere in which the attraction is housed has served as the symbolic structure of Epcot since the park opened in 1982.



Figure 25 – Epcot Center's Spaceship Earth (USA)

The architectural composition of Spaceship Earth bears resemblance in texture to the United States pavilion featured in Expo 67 held in Montreal. However, it distinguishes itself from the aforementioned construction by virtue of its complete spherical shape, which is upheld by three sets of paired supports. The architectural design was conceptualized by the Wallace Floyd Design Group. The user has provided references [5] and [6]. The architectural plans for both Expo 67 and Spaceship Earth were developed by Simpson Gumpertz & Heger Inc., an esteemed firm based in Boston, Massachusetts.

Spaceship Earth can be understood geometrically as being formed from a Class 2 geodesic polyhedron, specifically one with a frequency of division equal to 8. To construct each vertex of the polyhedron, three isosceles triangles are employed to partition each face. Theoretically, the number of isosceles triangles that can be formed is 11,520, which corresponds to a total of 3,840 distinct points. In actuality, a number of these triangles are either partially or entirely absent as a result of the presence of supports and doors. Consequently, the total count of silvered facets is reduced to 11,324, with 954 panels exhibiting partial or complete flat triangular shapes.

The architectural objective of attaining the semblance of a monolithic sphere was successfully accomplished by employing a structural technique. The term "spaceship" refers to a vehicle designed for travel and exploration in outer space

The Earth can be understood as consisting of two distinct structural domes. The structural support for the six legs is provided by pile groups that have been driven to a depth of 160 feet into the soft soil of Central Florida. The lower extremities provide structural support for a ring with a box-shaped configuration made of steel, positioned at approximately 30 degrees' south latitude on Earth. The user's text is already academic and does not require any rewriting. The higher structural dome is positioned atop the aforementioned ring. The ride and show system is supported by a grid of trusses located within the ring, which accommodates two helical constructions. Beneath the ring, a supplementary dome is suspended from the lower portion, therefore achieving the spherical configuration in its whole. The table-like structure composed of rings and trusses serves as a means of separation between the upper dome and the lower portion. The cladding sphere, which is situated approximately three feet above the structural domes, is supported by and encompasses the shining Alucobond panels and drainage system.

The coating was specifically engineered to prevent any water runoff onto the ground during rainfall events. The water is collected from the facets through small one-inch gaps and directed into a gutter system. Subsequently, the water is channeled into the World Showcase Lagoon.

7.A prototype of Geodesic Domes shelter:

7.1. Introduction:

Geodesic domes have long fascinated designers and architects due to their strength, efficiency, and visual appeal. Nonetheless, traditionally, the design and building of these elaborate structures required exact calculations and labor-intensive techniques. The use of Grasshopper and parametric modeling creates a novel and effective way for dealing with the complications of Geodesic dome design.

Furthermore, the construction of geodesic domes has the advantage of expedited building processes, resulting in reduced time and cost expenditures through the utilization of optimal materials. The utilization of a spherical form in their design additionally offers the potential for energy optimization and reduced material consumption. Moreover, owing to the inherent resistance and longevity exhibited by geodesic domes, the necessity for repairs and maintenance is significantly reduced in comparison to conventional buildings.

In brief, the utilization of geodesic domes as prefabricated shelters during periods of emergency has numerous benefits, encompassing expedited assembly, resilience against natural calamities, enhanced energy efficiency, efficient resource utilization, and diminished waste production. This study examines the ideal design of geodesic domes as prefabricated structures for shelter, specifically focusing on horizontal loads like wind, which the outcomes can be used and generalize for seismic activity.

The dimensions of the transparent glass geodesic dome can be modified to range from 3 meters to 12 meters in diameter. The glass geo dome tent represents a significant advancement in both its structural framework and its protective covering. The structural framework of the glass dome tent is constructed using a lightweight aluminum alloy that provides exceptional strength properties. Simultaneously prioritizing safety and wind resistance, the lightweight material effectively maintains the benefits of convenient transportation and rapid construction.

The glass geodesic dome tent cover offers a choose between typical PVC fabric and other options such as entirely clear glass or colorful glass. This decision not only improves the dome's ability to withstand weather conditions and snow, but also increases the overall value of the tent. Offering a tent space that facilitates proximity to the natural environment.

The safety performance of a glass geodesic dome house is remarkable. Glass exhibits excellent waterproof properties, keeping it resistant to heavy rainfall and guarantees that tents remain unaffected even when exposed to adverse weather conditions. The tent frame features a distinctive coated shell construction and is constructed using high-strength aluminum alloy profiles, enabling it to effectively endure strong winds ranging from 100 to 120 kilometers per hour. The tent has the capability to be constructed with ease in various locations, including but not limited to mountainous terrains, meadows, beaches, and deserts, even on soft ground. The glass geodesic dome tent exhibits a variety of outdoor uses, including not only its use as a tent house within outdoor holiday homes, but also being suitable for high-end commercial events, large-scale exhibitions, and other similar contexts. The event offers an enhanced experience through its exceptional values and distinctive structure.

7.2. Geodesic Domes Shelter Plans:

There are two types of shelters that are being taken into consideration:

The initial type is specifically engineered to accommodate a maximum of two individuals, and it possesses a circular shape with a diameter measuring six meters; the subsequent type is exclusively designed to house four individuals, and it features the characteristic of having a diameter of eight meters.

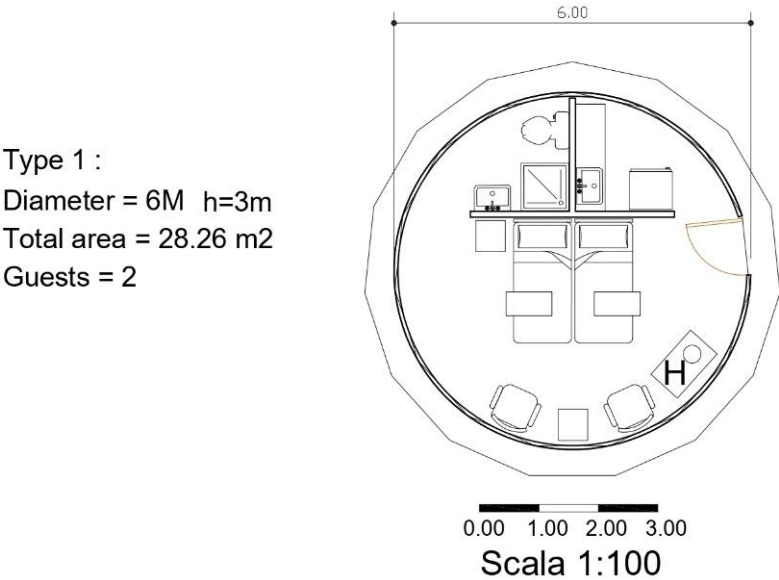

Figure 26 – Geodesic Domes Shelter Plan type 1

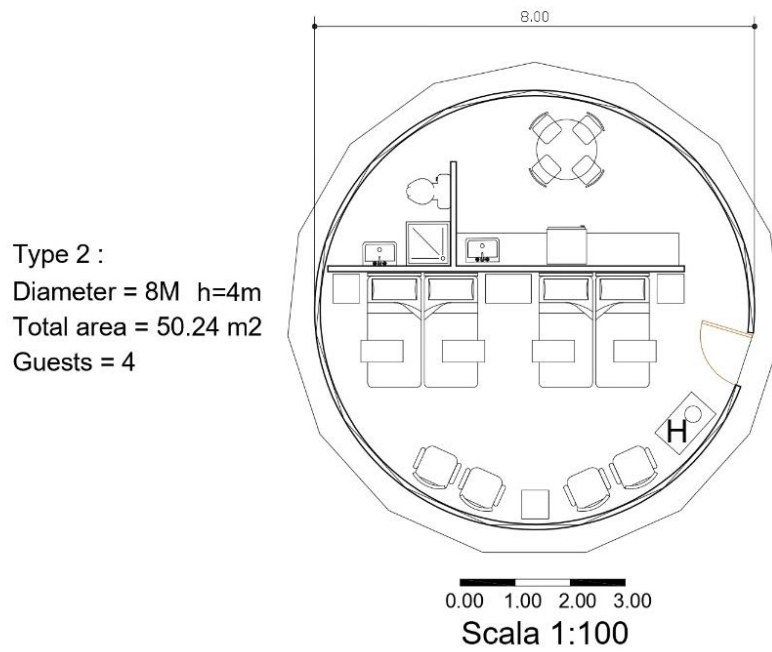

Figure 27 – Geodesic Domes Shelter Plan type 2

7.3. Domes shelter 3D models:



Figure 28 – Geodesic Domes Shelter Interior view



Figure 29 – Geodesic Domes Shelter exterior view
number01



Figure 30 – Geodesic Domes Shelter exterior view
number02

8. Geodesic dome Generative Design:

8.1. generate a mesh icosphere:

In order to create a geodesic dome structure, several sequential stages must be followed. Initially, an icosphere is rendered, accompanied by input and output data. As it is seen in the visual representation, three inputs are present, namely the plane, scale, and density. Additionally, there is a specific output known as a "mesh." We will generate a mesh icosphere.

The default plane of reference is the XY plane, and we establish a scale using a number slider ranging from 1 to 20, with three decimal places. it is the range of values for the radius of an icosphere. In order to quantify density, we provide a numerical slider that represents the frequency count within the range of 1 to 5 as an integer value.

Icosphere: Create a mesh icosphere.

Number slider: numeric slider for single values Radius of Dome

R: $1.000 \leq R \leq 20.000$, range=19

Frequency of Dome

F: $0 \leq F \leq 6$, range=6

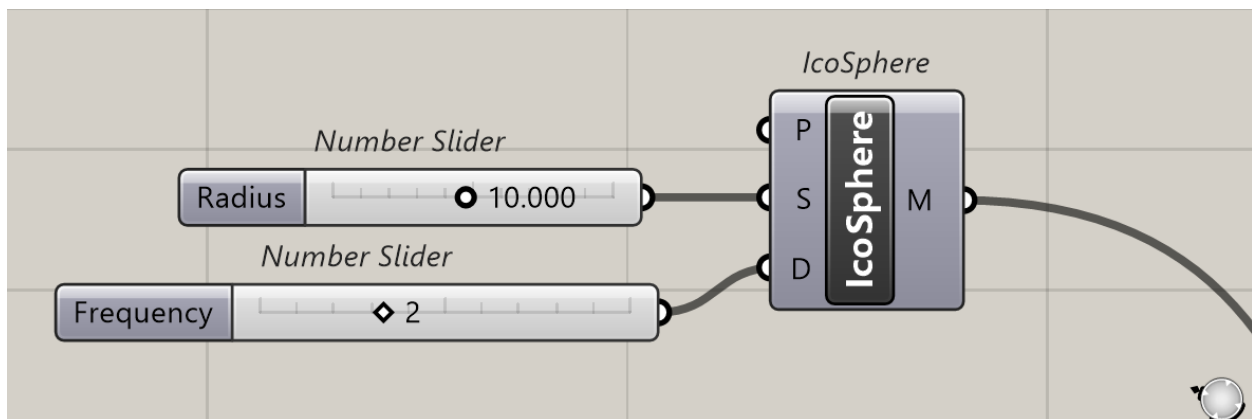

Figure 31 – generate a mesh icosphere in grasshopper environment

8.2. Mesh rotation on mid geodesic line:

In the present context, our objective is to perform a sectioning of the icosphere along the XY plane, resulting in the creation of two geodesic domes. Additionally, we aim to remove the portion of the icosphere that lies in the negative (-z) axis direction. The problem refers to the split line that is located in the XY plane, which forms the boundary between two sections of the icosphere. Specifically, we have encountered a loss of certain edges within the subdivided bottom region in the border of two icosphere. The icosphere conducts a rotational process as described below in order to achieve a geodesic dome configuration where all mesh edges are positioned at the bottom.

In order to achieve the desired geodesic dome design, as depicted in the provided image (yellow box), it is necessary to first rotate the icosphere. This rotation is performed using a rotate component that accepts three input values. Subsequently, the icosphere is divided into two parts to facilitate the creation of the geodesic dome. at the dome there are obvious planes that split it in half without splitting existing triangles. we rotate the "icosphere" in the YZ plane by 31.7175 degrees in the X direction, as determined by the angle defined by the arctangent expression ($\text{atan}((1+5^{0.5})/2)$), so that the split line is exactly on the XY plan.

For mesh rotation on mid geodesic line these components are used:

Rotate: rotate an object in a plane

Rotate Axis: rotate an object around an axis

construct point: construct a point from {xyz} coordinates

Line SDL: create a line segment defined by start point, tangent and length.

unit x: unit vector parallel to the world {x} axis.

YZ plane: world YZ plane.

expression: evaluate an expression ($\text{atan}((1+5^{0.5})/2)$)

In Grasshopper, the expression " $\text{atan}((1+5^{0.5})/2)$ " be understood as a mathematical calculation using trigonometric functions. there is the explanation of equation step by step below:

" $(1+5^{0.5})$ " means the square root of 5 (represented as " $5^{0.5}$ ") is added to 1. This part calculates the value of $(1 + \sqrt{5})$.

"/2" indicates that the value obtained in step 1 is divided by 2.

"atan ()" is the inverse tangent function. It takes the result from step 2 and returns the angle whose tangent is equal to that value.

In summary, the expression calculates the inverse tangent of $((1+\sqrt{5})/2)$. The resulting value represents an angle in radians.

In Grasshopper, you can use this expression within a component that requires input values or functions. It could be utilized, for example, in a script to determine an angle for controlling the orientation of an object or a specific geometric operation within a design process.

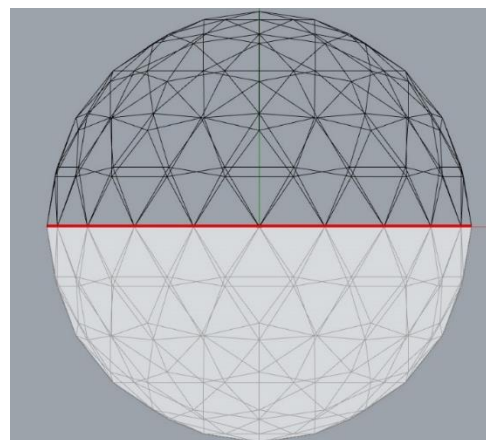
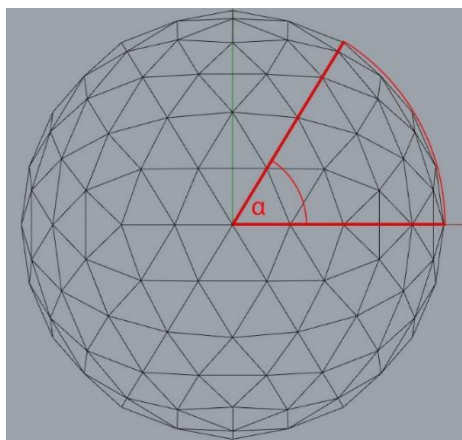
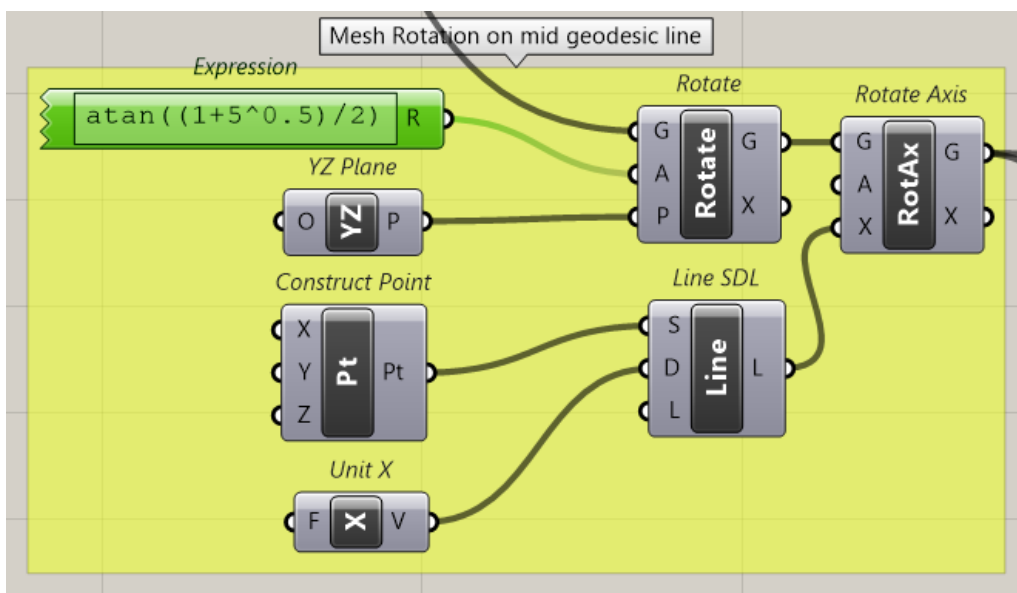

$$\alpha \approx \text{atan} \left(\frac{1 + 5^{0.5}}{2} \right) \approx 58^\circ.2825256$$

Figure 32 – Mesh rotation on mid geodesic line

Then get all the edges of a mesh:

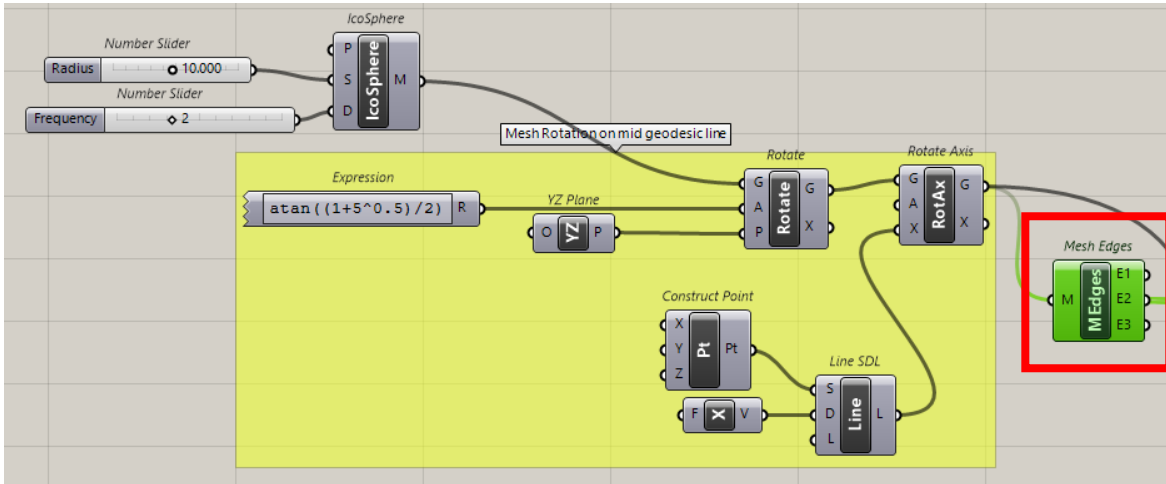

Figure 33 – get all the edges of a mesh

8.3. List of positive mesh edges(+z):

In the subsequent analysis, we extract the favorable interconnections of the mesh (edges) using the below procedure, as visually depicted in the picture. Additionally, we employ the Karamba 3D to eliminate repeated lines from the model.

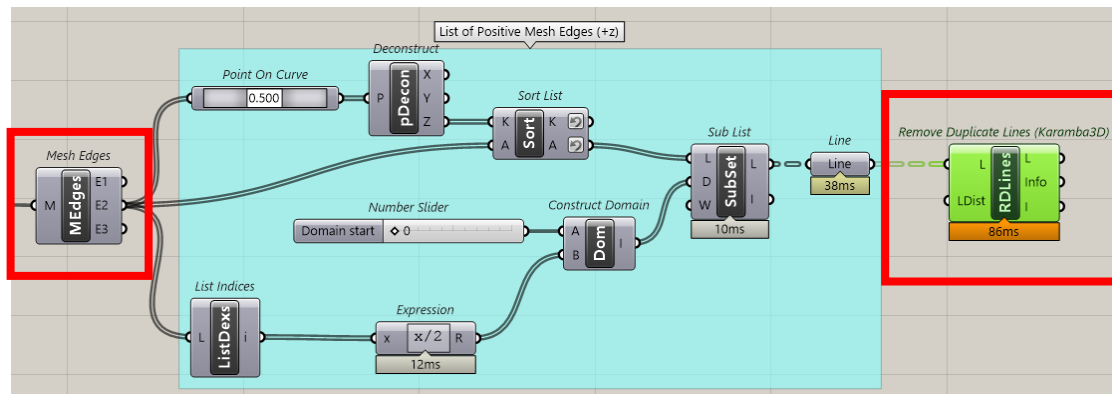

Figure 34 – List of positive mesh edges(+z)

Point on curve: evaluates a curve at a specific location. (it is equal 0/500)

Deconstruct (pDecon): Deconstruct a point into its component parts.

sort list: sort a list of numeric keys.

reverse: data inside this parameter is reversed.

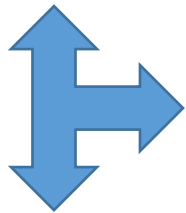

SUB List: extract a subset from a list

Line: contains a collection of line segments.



Remove Duplicate Line (Karamba 3D):

Eliminates identical lines from the given set of lines.

list indices: get a list of the indices from a list of items.

Expression: evaluate an expression. (x/2)

Construct Domain: create a numeric domain from two numeric extremes.

domain start=ds: $0 \leq ds \leq 100$, range=100

8.4. List of positive points (+z):

Next, the objective is to show the steps taken to obtain the List of positive points (+z) from a given mesh. The process involves using various components in Grasshopper, a visual programming language commonly used in architectural design and engineering.

To begin with, we start by using the “Deconstruct Mesh” in grasshopper which deconstruct a mesh into its component parts.

there will be 4 keys value as output (mesh vertices, mesh faces, colors, mesh normal) as a list, we extract just mesh vertices as input to point component so we will have all vertices points then deconstruct all point to their components part (x, y, z).

after that we extract z coordinate and sort them which is between -10 and 10, then we choose points index by list item and by defining an expression(x-y), and put

y=10.5 then with Larger than component we extract the list of positive points in z direction.

"Evaluate Mesh" component to extract its vertices. The vertices, which are represented as three-dimensional points, are then sorted using the "Sort List" component.

In the next step, we use the "Deconstruct" component to break down each point into its individual x, y, and z coordinates. We are only interested in the points with a positive z-coordinate, which represent the portion of the mesh that is above the x-y plane. To filter out the negative z-coordinates, we use the "Larger Than" component with a threshold value of 0.

However, this step still leaves us with duplicate points, which need to be removed. To achieve this, we use the "Cull Pattern" component to remove elements in the list using a repeating bit mask. This step ensures that there are no duplicate points in the final list.

Lastly, we add a custom note to the "Panel" component to indicate the length of the list and how many points were eliminated during the culling process.

In conclusion, the List of positive points (+z) was obtained by using a combination of components that extract, sort, filter, and eliminate duplicate points from the original mesh in Grasshopper. This list can now be used for further analysis and design purposes.

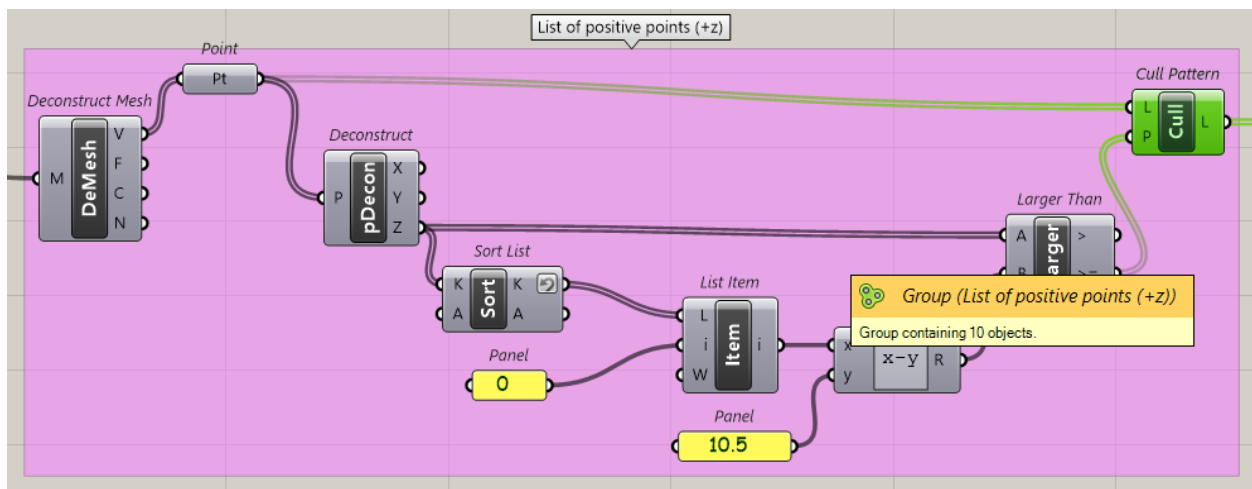

Figure 35 – List of positive points (+z)

Deconstruct Mesh: Deconstruct a mesh into its component parts.

point: contains a collection of three-dimensional points.

Deconstruct: Deconstruct a point into its component parts.

sort list: sort a list of numeric keys.

list item: retrieve a specific item from a list.

Expression: evaluate an expression (x-y)

panel: a panel for custom notes and text values. (y= 10.5)

larger than: larger than (or equal to)

cull pattern: cull (remove) elements in a list using a repeating bit mask.

8.5. the split line on the XY plane:

Based on the depicted image, it can be determined that a ring-shaped line will be positioned precisely within the XY plane.

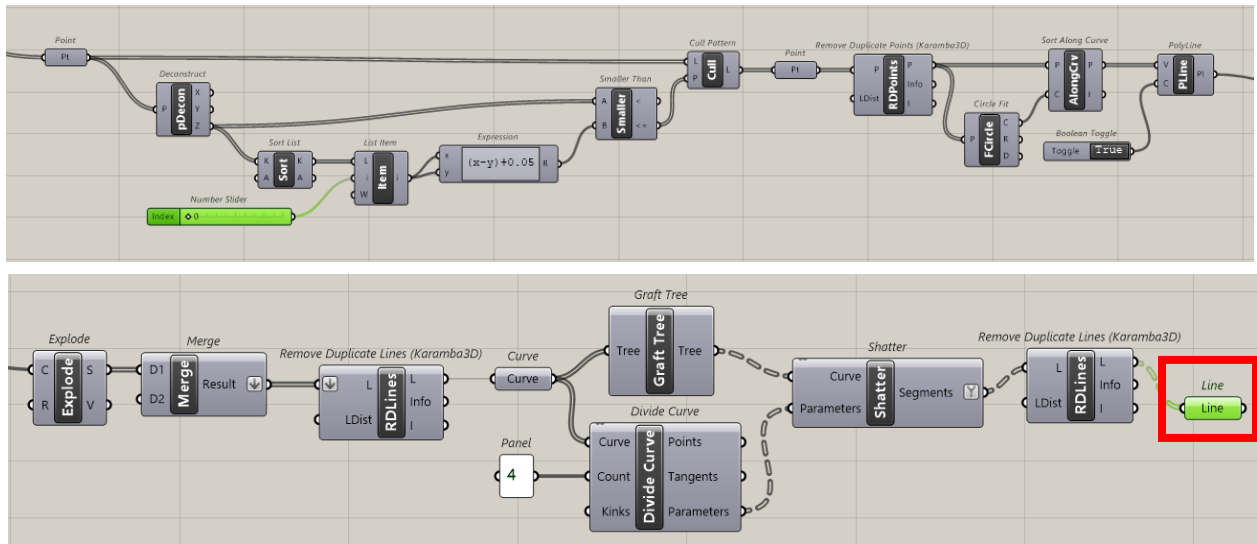

Figure 36 – the process of the split line on the XY plane

9. Geodesic dome structural Optimization:

9.1. Structural Analysis with Alpaca4D:

Geodesic domes are structures made of triangles that are linked to each other and make a sphere or a part of a sphere. Usually, analyzing these kinds of buildings means figuring out how stable they are, how much weight they can hold, and how they will act under different loads.

In general, finite element analysis (FEA) can be used to figure out how to analyze geodesic domes. For FEA, the structure is broken up into smaller finite elements, like triangles for geodesic domes, and the equations of motion and stability are solved for each element. The structure's general behavior is then figured out by putting together how each part acts.

FEA is usually used to do the following steps to examine a geodesic dome:

Geometry modeling: A geometric model of the dome is made, including its size, position of nodes, and how the triangles that make up the dome are connected.

Material properties: The dome's material qualities, such as its density and elasticity modulus, are described. The way the structure reacts to loads depends on these properties.

Conditions at the edges: The supports and limits at the edges of the dome are described. These factors determine how the building works with its surroundings.

Load application: The dead loads, live loads, wind loads, and snow loads that the dome is supposed to experience are added to the model. The size, speed, and location of the loads are all taken into account.

Analysis and solution: The FEA program solves the equations of motion and equilibrium for each finite element by taking into account the geometry, material properties, boundary conditions, and loads. The software figures out how each part and element is being stressed, moved, and reacting.

After the research is done, the results are looked at and figured out. They might include stress patterns, deformations, reaction forces, and stability factors. These results help figure out how well the geodesic dome is built and how well it works.

In this study the structural analysis of a geodesic dome describes by using a plugin called Alpaca4D, which is based on the OpenSees software developed by researchers at the University of California, Berkeley.

The dome's structure is modeled using steel material with a specific grade called S355. The members of the dome are represented using circular hollow core section elements. The boundary conditions of each member are fixed-fixed, meaning they are fully restrained at both ends, and the entire dome is supported at the base.

Two different load cases are considered: the ultimate limit state (ULS) and the service limit state (SLS). The SLS load case focuses on maximum deformation and uses a load combination specified in the Euro code standard.

The loads in the structural model include the self-weight of the dome, which is automatically calculated based on the specific cross-section of each member. There is also a permanent load defined as 1.00 KN/m² of the dome's surface, taking into account the roofing system's characteristics (e.g., glass panels and connections to the frame). Additionally, there is a horizontal wind load.

The wind load is determined based on the technical procedure outlined in the Italian regulation for structural design (NTC2018). It depends on the wind pressure, which is calculated using a formula that considers factors like air density, wind velocity, and dome location. In this case, the dome is hypothetically located in Turin, Italy, at an elevation of 12 meters in an urban area. The wind pressure for the dome is determined to be 18.75 (p=18.75 N/m²). Finally, the wind load is distributed as point loads across all nodes of the dome's structure. The total wind load affecting the dome is approximately 3 KN. (P=3 KN).

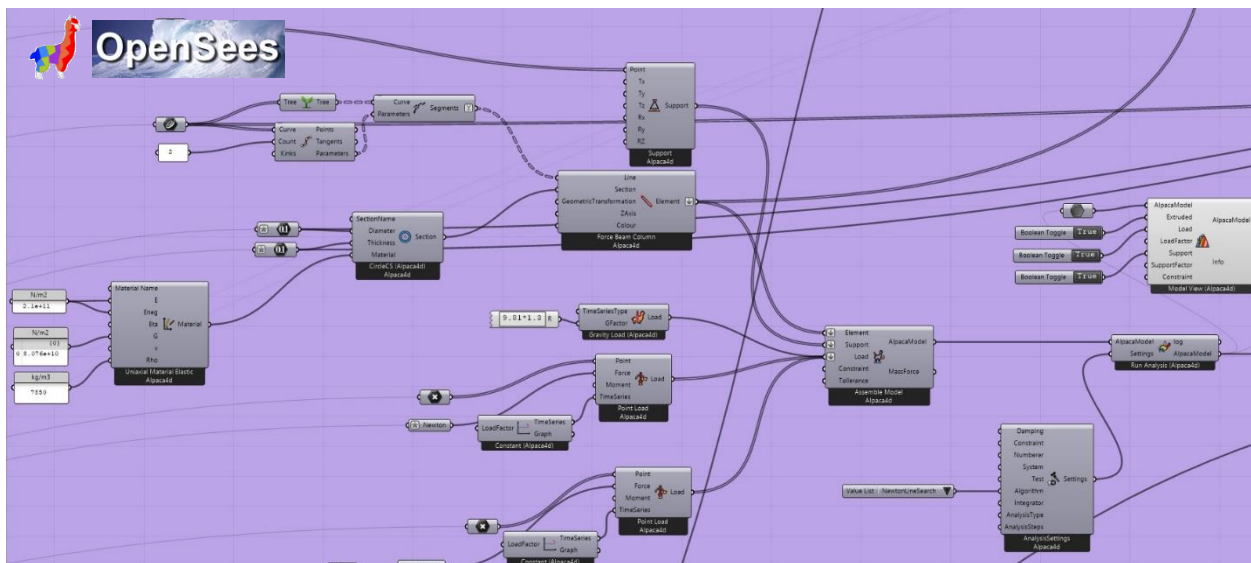

Material Implementation:

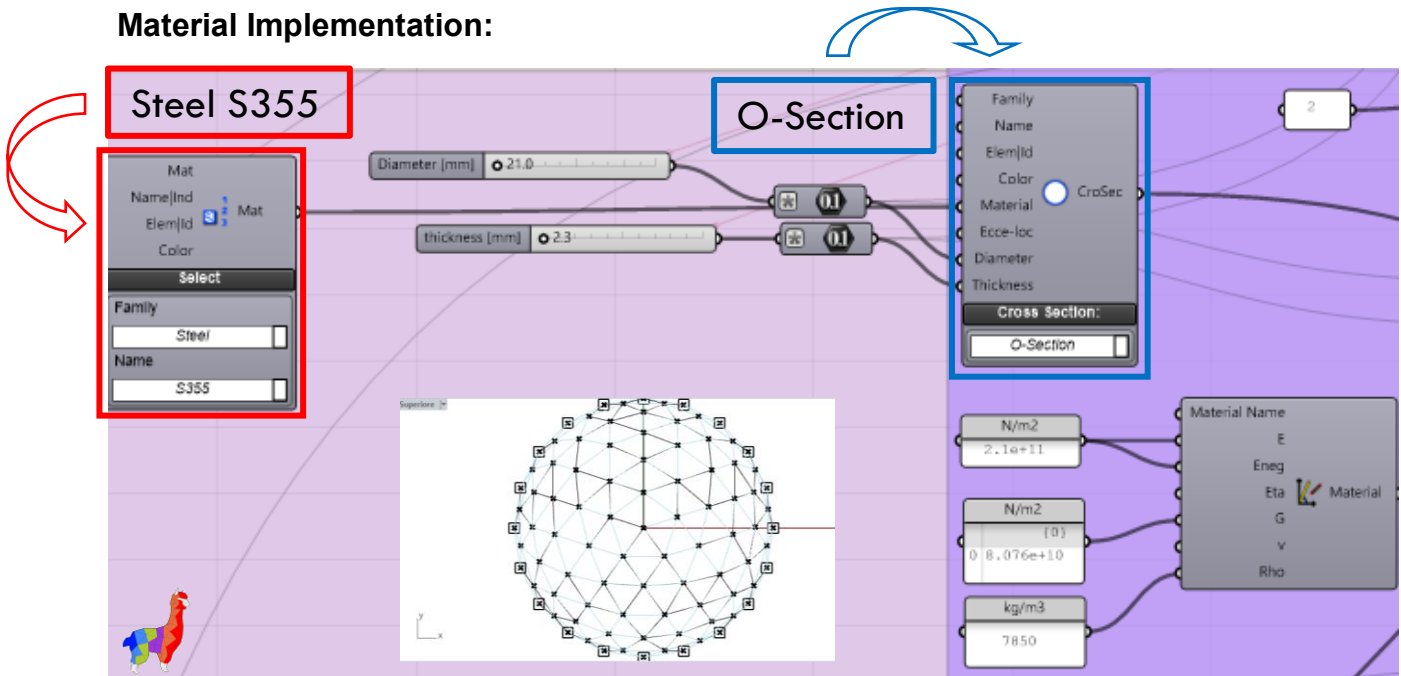

Figure 37 – Material Implementation

Load Implementation:

The wind load acting on the dome is approximately equal to $P=3 \text{ kN}$.

All actions are distributed as point loads in all nodes of the dome.(Wind load=NTC2018)

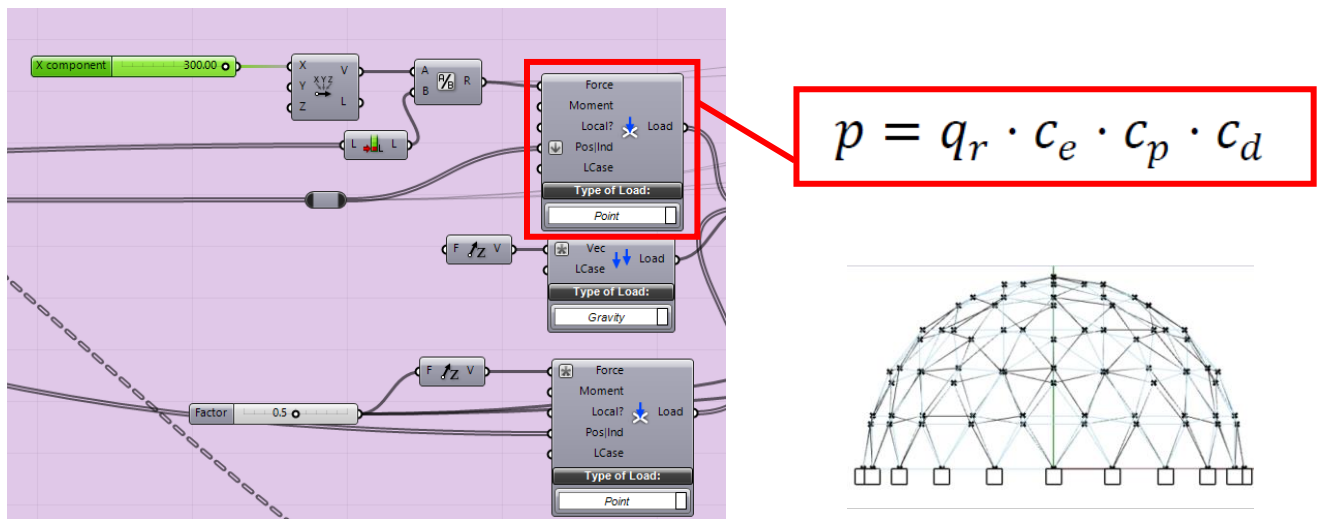

Figure 38 – Load Implementation

9.2. Size Optimization:

We use the meta-heuristic based Galapagos tool in Rhinoceros Grasshopper to optimize the geodesic dome mentioned earlier. Reduced material consumption equals lower manufacturing costs for the dome's structural components, which makes the size optimization problem consistent with traditional truss optimization problems. The two primary components encoded in the design vector x are the thickness t in millimeters of each tubular section and the outer diameter ϕ in millimeters of the circular hollow section (CHS) used for each dome element.

$$x = [x(1), x(2)]^T = [\phi, t]^T$$

For the purpose of locating the ideal values for every element of the design vector, the writers have established appropriate ranges. These ranges are based on the market availability of standard circular hollow section (CHS) profiles (Eurocode standards for steel structures, EN 1993-1-1:2005+AC2:2009 Sections 6.2 and 6.3). These acceptable and reasonable intervals have the following definitions:

$$21.3 \text{ mm} \leq \phi \leq 1219 \text{ mm}$$

$$2.3 \text{ mm} \leq t \leq 60 \text{ mm}$$

the problem statement of constrained size optimization can be formulating as follows:

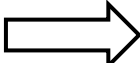
Objective Function  $\min V(x) = \sum_i A_i(x)L_i$

The steel volume of the entire dome is represented by $V(x)$, which is based on the length L_i and the CHS cross-section $A_i(x)$ of each adopted member.

Constraints:

g1: The thickness selection must be less than half of the CHS external diameter due to a geometrical feasibility requirement.

g2: permitted tensile strength of every steel component.

g3: The maximum compressive strength of every steel component.

g4: represents the displacement restriction in terms of the geodesic dome's base radius.

$$\begin{aligned}g_1(\mathbf{x}) &= \frac{x(2)}{\frac{x(1)}{2}} - 1 \leq 0 \\g_2(\mathbf{x}) &= \frac{N_{Ed,t}(\mathbf{x})}{N_{Rd,t}(\mathbf{x})} - 1 \leq 0 \\g_3(\mathbf{x}) &= \frac{N_{Ed,c}(\mathbf{x})}{N_{Rd,b}(\mathbf{x})} - 1 \leq 0 \\g_4(\mathbf{x}) &= \frac{u_{max}}{u_{lim}} - 1 \leq 0\end{aligned}$$

In the preceding equations, $V(\mathbf{x})$ represents the total steel volume of the entire dome, which depends on the cross-sectional area $A_i(\mathbf{x})$ of each i -th member with its adopted CHS and its length L_i . The initial constraint, $g_1(\mathbf{x})$, enforces a geometric feasibility condition, ensuring that the chosen thickness is less than half of the external diameter of the CHS. Constraints $g_2(\mathbf{x})$ and $g_3(\mathbf{x})$ pertain to adhering to the design criteria for ultimate limit state (ULS) conditions concerning members subjected to tensile forces $N_{Ed,t}(\mathbf{x})$ and compressive forces $N_{Ed,c}(\mathbf{x})$. In particular, $g_2(\mathbf{x})$ addresses the permissible tensile strength of each steel member, as defined by the following:

$$N_{Rd,t}(\mathbf{x}) = \frac{A_i(\mathbf{x}) \cdot f_y}{\gamma_{M0}}$$

Here, f_y denotes the steel strength, typically 355 MPa, except when the chosen thickness exceeds 40mm. In that case, the maximum strength is capped at 255 MPa. The coefficient γ_{M0} serves as a partial safety factor, considering uncertainties inherent in the semi-probabilistic calculation method, often assumed to be 1.1. On the other hand, $g_3(\mathbf{x})$ addresses the structural evaluation of members under compression, accounting for potential Eulerian buckling phenomena. Consequently, the resistance to compression at the ultimate limit state (ULS) is defined as follows:

$$N_{Rd,b}(\mathbf{x}) = \chi \frac{A_i(\mathbf{x}) \cdot f_y}{\gamma_{M1}}$$

The reduction factor χ can be calculated following the Eurocode 3 guidelines, which align with the procedures outlined in NTC18. When dealing with a hot-rolled circular hollow section (CHS) profile made of S355 steel, the instability curve is referred to as "curve a," resulting in an imperfection factor of $\alpha = 0.21$. This factor takes into account the real-world imperfections present in structural members, as opposed to the idealized Eulerian buckling of perfect structural elements. Subsequently, a dimensionless slenderness parameter needs to be determined.

Lastly, the constraint $g_4(x)$ articulates the restriction on displacement to a reasonable value under the serviceability limit state (SLS) characteristic design condition, with reference to the base radius R of the geodesic dome.

$$u_{lim} = \frac{1}{250}R$$

The steel volume of the entire dome is represented by the $V(x)$ in the preceding equations, which use the penalty function to solve an unconstrained optimization problem:

$$\min V(x) = \sum_i A_i(x)L_i$$

↓

$$\min \Phi(x) = V(x) (1 + k_p \cdot \Pi(x))$$

$k_p = 100$

$$\Pi(x) = \sum_j^4 \max\{g_j(x), 0\}$$

The constrained optimization problem presented in Eqs. $\min V(x)$, $g_1(x)$, $g_2(x)$, $g_3(x)$, $g_4(x)$, has been redefined as an equivalent unconstrained optimization problem by employing the penalty function approach. Consequently, a new objective function is articulated, taking into account an adaptable penalty term $\Pi(x)$:

$$\min \Phi(x) = V(x) (1 + k_p \cdot \Pi(x))$$

A penalty factor kp has been fixed at $kp = 100$. This penalty term is considered adaptable because it increases the original volume in cases where one or more constraints are violated. As a result, $\Pi(x)$ holds a value greater than zero when an individual from the population is infeasible, and it equals zero otherwise:

$$\Pi(x) = \sum_j^4 \max\{g_j(x), 0\}$$

9.3. parametrized frequency:

The definition of a distinct search space topology depends on the frequency of the dome. Consequently, the frequency is parametrized and discussed the outcomes for frequencies of 1 and 2. The size optimization problem with the geodesic dome frequencies parametrized is reported, along with its results.

9.3.1. Frequency order 1:

The optimization problem, which involved finding the optimal solution while adhering to all constraints, was effectively resolved through the utilization of the Galapagos Evolutionary tool integrated within the Grasshopper software. After undergoing an intensive process of 100 generations, a meticulous examination of the results revealed that the exact optimal solution for frequency 1 was successfully obtained.

$$\mathbf{x}_{\text{opt, frequency}=1} = [\boldsymbol{\phi}_{\text{opt}}, \mathbf{t}_{\text{opt}}]^T = [43.7 \text{ mm}, 2.4 \text{ mm}]^T$$

The figure 39 depicted in this study provides a comprehensive and visually appealing three-dimensional representation of the structural model. It showcases the optimal values of the design vector, which have been carefully selected to ensure the highest level of effectiveness and efficiency in the overall design. Moving forward, the figure 40, specifically labeled as (a), presents an informative and insightful illustration of the objective function history. This graph allows us to track and analyze the changes and fluctuations in the objective function throughout the iterative process. On the other hand, the second part of the figure 40, represented as (b), offers a contrasting yet equally significant visual representation. This particular aspect of the figure focuses on showcasing the bio-diversity ratio. In summary, these two figures play a crucial role in providing a comprehensive and holistic understanding of the structural model's effectiveness. The mentioned latter pertains to a numerical representation, expressed as a

percentage, which serves to illustrate that the Evolutionary tool continues to explore the search space, even though a superior solution has already been discovered in the early generations. This exploration ultimately leads to the attainment of an optimal steel volume of 0.06 m^3 , aligning precisely with the designated design parameters. However, in order to offer a more pragmatic and feasible structural solution, the mentioned design parameters were rounded up to the nearest Circular Hollow Section (CHS) steel profile that is readily available in the market, in accordance with the guidelines outlined in the EN 1993-1-1:2005+AC2:2009 Sections 6.2 & 6.3. Consequently, the most optimal technical approach for the size optimization of the geodesic dome under examination has been identified, and this approach is characterized by the pronounced attention to detail and adherence to accurate design parameters. dome's frequency equal 1 is:

$$\mathbf{x}_{opt, frequency=1}^* = [\phi_{opt}^*, t_{opt}^*]^T = [48.3 \text{ mm}, 2.6 \text{ mm}]^T$$

the given volume, which can be denoted as 0.073 m^3 , resulting in a slightly higher value.

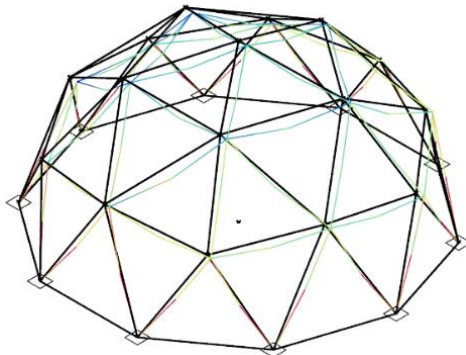

Figure 39- 3D view of the optimal geodesic dome with frequency equal to 1 (black) and the deformed shape (colored)

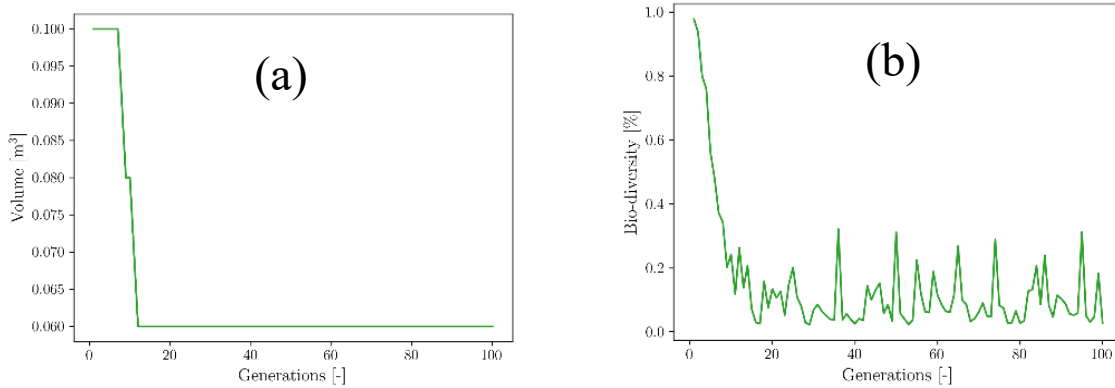

Figure 40- Geodesic dome with frequency 1. (a) Best fitness value of the first element of the sorted population for every explored generation. (b) Bio-diversity ratio during the generations.

9.3.2. Frequency order 2:

On the opposing side, it is worth mentioning that the process of optimizing for frequency 2 entails a rigorous and systematic examination and analysis, which ultimately produces a result that is deemed to be the most precise and accurate solution available. This meticulous and thorough process is characterized by its focus on achieving an optimal outcome that is in complete accordance with the desired objectives and requirements. It is important to note that the optimization process for frequency 2 necessitates a comprehensive and exhaustive exploration of various possibilities and alternatives in order to arrive at the most favorable and advantageous resolution. In light of this, it is crucial to acknowledge that the resulting optimal solution obtained through this elaborate procedure is indeed the most suitable and ideal one.

$$\mathbf{x}_{\text{opt, frequency}=2} = [\boldsymbol{\phi}_{\text{opt}}, \mathbf{t}_{\text{opt}}]^T = [21.7 \text{ mm}, 3.4 \text{ mm}]^T$$

The solution mentioned above, which adheres to all of the imposed restrictions, demonstrates a high level of respect for the various constraints. Additionally, this solution is associated with an optimal volume of 0.08 m^3 . In order to visually represent the structural model with the optimal values of the design vector, Figure 41 displays a three-dimensional depiction. Furthermore, the objective function history throughout the iterations is presented in Figure 42 (a), while Figure 42 (b) showcases the bio-diversity ratio. To ensure a more practical and

realistic structural solution, the exact design parameters were rounded up to the nearest CHS steel profile that is readily available on the market, in accordance with the EN 1993-1-1:2005+AC2:2009 Sections 6.2 & 6.3. Therefore, the size optimization of the geodesic dome under investigation, with a frequency of 2, has resulted in an optimal technical solution:

$$\mathbf{x}_{opt, frequency=2}^* = [\phi_{opt}^*, t_{opt}^*]^T = [26.9 \text{ mm}, 3.2 \text{ mm}]^T$$

to which a slightly higher volume is equivalent, as expressed by a value of 0.095 m^3 , can be observed. It is important to note that this solution remains in compliance with all the prescribed limitations and requirements.

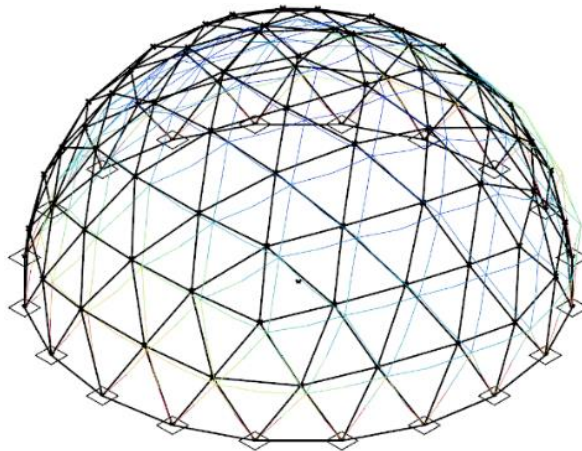

Figure 41- 3D view of the optimal geodesic dome with a frequency equal to 2 (black) and the de- formed shape (colored).

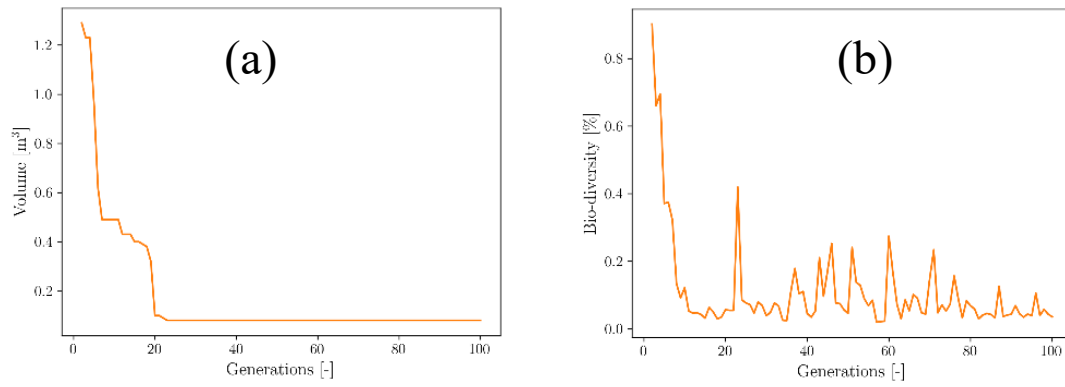

Figure 42- Geodesic dome with frequency 2. (a) Best fitness value of the first element of the sorted population for every explored generation. (b) Bio-diversity ratio during the generations.

10.Conclusion:

The construction industry has a lot of potential when it comes to using numerical optimization techniques to design structures that are cost- or material-efficient. This industry, which accounts for a significant amount of the world's natural resource consumption, stands to gain a great deal from structural optimization since it helps lower resource consumption, which in turn improves the industry's sustainability. Furthermore, by automating the tedious process of sizing structural members, the application of structural optimization techniques can lower engineering costs in addition to construction costs. Thus, the application of structural optimization can lead to the creation of innovative design solutions for particular structural elements or materials, promoting the advancement of the construction engineering discipline. Three main approaches can be identified in the field of structural optimization are topology optimization, size optimization, and shape optimization. While shape optimization entails parameterizing the structure's shape and optimizing these parameters, size optimization concentrates on figuring out the ideal dimensions of structural components. Topology optimization, on the other hand, seeks to determine the ideal spatial distribution of structural elements or materials.

Many unknowns are frequently present in structural engineering problems encountered in the real world. Real loads, material characteristics, and geometry frequently differ from the estimated values during the design stage. The structure's performance may be strongly impacted by these uncertainties. Therefore, in the framework of structural optimization, it is imperative to guarantee that the initial design's sensitivity to uncertainties is kept to a minimum while simultaneously optimizing its performance. This calls for the application of reliable and strong design optimization methods that take uncertainty into account during the optimization process. Structural optimization, by incorporating uncertainty considerations, can produce designs that are robust against unforeseen variations in loads, material properties, and geometry, in addition to being efficient.

In this thesis, our objective is to assess the efficiency of geodesic domes by considering not only the gravitational force exerted by the structure itself, but also the impact of the asymmetrical horizontal load, commonly referred to as wind action. In order to accomplish this, we will conduct a thorough analysis using the Finite Element Method (FEM), which will allow us to collect the necessary data required to obtain an optimal solution. This comprehensive analysis will involve

the evaluation of two distinct dome frequencies, thereby enabling us to explore a wide range of possibilities and scenarios. The findings of our study reveal that there are no violations of the constraints that have been imposed, while simultaneously achieving a reduction in both the volume of the structure and the computational costs. This noteworthy accomplishment can be attributed primarily to the exceptional performance of the script that was employed throughout the entire process. It is crucial to note that the workflow that has been established here serves as a solid foundation for future research endeavors, particularly those that involve seismic activities. This is made possible by the integration of generative design, which encompasses the parameterization of geometric data, with the use of Open-Sees, a software that is specifically designed to simulate the behavior of structural and geotechnical systems when exposed to earthquake-induced forces. Although the application of this study was specifically focused on geodesic domes, it is worth highlighting that the workflow that was implemented is highly versatile and can be adapted to various analyses and optimization procedures, even extending its application to encompass different types of structures that feature diverse structural systems.

11. Bibliography:

Laura Sardone, Marco Martino Rosso, Jonathan Melchiorre, and Marco Pellegrino," Generative Design Process and Optimization of Geodesic Dome with Variable Frequency " Department of Structural, Geotechnical and Building Engineering, Politecnico di Torino (2023)

Gythiel, Willem, Christiaan Mommeyer, Tom Raymaekers, and Mattias Schevenels. "A comparative study of the structural performance of different types of reticulated dome subjected to distributed loads." *Frontiers in Built Environment* 6 (2020): 56.

Kubik, Marek, and Charles Augarde. "Structural Analysis of Geodesic Domes." *Final Year Project. Durham University, School of Engineering* (2009).

Saka, M. P. "Optimum geometry design of geodesic domes using harmony search algorithm." *Advances in Structural Engineering* 10, no. 6 (2007): 595-606.

Jones, Cecil Allen. "Design and an automated parametric study of geodesic domes." PhD diss., Virginia Polytechnic Institute and State University, 1978.

Dasari, Saaranya Kumar, Nicholas Fantuzzi, Patrizia Trovalusci, and Roberto Panei. "Computational approach for form-finding optimal design." *Architecture, Structures and Construction* 2, no. 3 (2022): 323-333.

Mirjalili, Seyedali, Jin Song Dong, Ali Safa Sadiq, and Hossam Faris. "Genetic algorithm: Theory, literature review, and application in image reconstruction." *Nature-Inspired Optimizers: Theories, Literature Reviews and Applications* (2020): 69-85.

Talasioglu, Tugrul. "Optimal dome design considering member-related design constraints." *Frontiers of Structural and Civil Engineering* 13 (2019): 1150-1170.

<https://discourse.mcneel.com/t/rotate-a-geodesic-dome-so-the-hemi-sphere-split-is-on-the-xy-plane/155715>

<https://www.ecology.gen.tr/ecological-design/67-biosphere-2.html>

<https://www.edenproject.com/mission/about-our-mission/architecture>

<https://hopific.com/expression-editor-in-grasshopper>

12.Acknowledgements:

I am deeply grateful for the abundant support and guidance extended to me during the development of this thesis. Foremost, my heartfelt appreciation goes to Professor Giuseppe Marano, whose invaluable expertise and knowledge significantly contributed to shaping the research inquiries and methodology. Additionally, I extend my sincere gratitude to Laura Sardone for her insightful guidance throughout my academic journey, equipping me with the necessary tools for thoughtful decision-making and the completion of this dissertation.

I wish to acknowledge my parents for their unwavering support, which has been a constant source of strength.

Lastly, I dedicate this thesis to the memory of my younger brother, Nima, whose recent loss I deeply mourn. His presence is dearly missed, and I wish he could be here with me at this moment.