



**Politecnico
di Torino**

Politecnico di Torino

Master's Degree in Engineering and Management

A.y. 2022/2023

December 2023

Advancing Project Schedule Control Beyond Traditional EVM: A Literature Review

Relatore:

De Marco Alberto

Candidato:

Saffirio Alberto

Corelatori:

Ottaviani Filippo Maria

Wong Jason

Abstract

A primary goal of project managers is to guarantee that projects are executed in adherence to their planned cost and duration. Nonetheless, because real-life initiatives are inherently uncertain, projects are rarely completed precisely within the allocated budget and timeline, making it necessary for managers to maintain a proactive approach throughout the project's lifecycle to minimize any potential deviations. Therefore, effective monitoring and control are crucial in ensuring project successful delivery.

Over the years, several methodologies have been put out with the objective of providing managers with the proper tools needed to carry out such activities. Among them, one that garnered widespread use and acclaim among practitioners is Earned Value Management (EVM), mainly due to its remarkable simplicity and broad applicability. Nevertheless, traditional EVM presents several limitations, and various alternative approaches have been developed in an effort to overcome them.

The purpose of this paper is to address the gaps in EVM related to schedule monitoring and control. Indeed, while research has long prioritized cost management in projects, a compelling need arises to redirect focus toward schedule performance—an aspect that has received comparatively limited attention. Specifically, innovative solutions designed to overcome the main drawbacks of EVM time performance indicators are offered through an extensive literature review. The methodologies discussed in this essay are categorized into two main groups, i.e., top-down and bottom-up project control, each representing distinct approaches to the challenge of schedule monitoring. The former encompasses a set of EVM-based novel metrics and techniques, while the latter focuses on Schedule Risk Analysis (SRA) and activities sensitivity assessment. Furthermore,

a method that amalgamates EVM and SRA into a single integrated system is analyzed. To conclude, a qualitative comparison of the various approaches discussed is carried out, evaluating their effectiveness in addressing EVM's limitations and improving project schedule management.

Table of Contents

Introduction.....	8
Chapter 1	10
Project Management	10
1.1 Fundamentals of Project Management.....	11
1.2 Monitoring and Controlling	14
Chapter 2.....	17
Earned Value Management	17
2.1 Fundamentals of EVM.....	19
2.2 S-Curves.....	20
2.2.1 <i>From the Project Plan to the Planned Value Curve</i>	22
2.3 EVM Metrics	26
2.3.1 <i>Variance Analysis</i>	26
2.3.2 <i>Performance Indexes</i>	27
2.4 EVM Limitations in Schedule Monitoring	31
Chapter 3.....	34

Methodology	34
Chapter 4	41
Results	41
4.1 Top-down Project Control.....	42
4.1.1 Anbari, F. T. (2003). <i>Earned value project management method and extensions.</i>	44
4.1.2 Jacob, D. (2003). <i>Forecasting project schedule completion with earned value metrics.</i>	45
4.1.3 Lipke, W. (2003, January). <i>Schedule is different.</i>	46
4.1.4 Khamooshi, H., & Golafshani, H. (2014). <i>EDM: Earned duration management, a new approach to schedule performance management and measurement.</i>	48
4.1.5 Hillson, D. (2014). <i>How risky is your project — And what are you doing about it?...</i>	54
4.1.6 Bagherpour, M., Zareei, A., Noori, S., & Heydari, M. (2009). <i>Designing a control mechanism using earned value analysis: An application to production environment.</i>	56
4.1.7 Pajares, J., & López-Paredes, A. (2011). <i>An extension of the EVM analysis for Project Monitoring: The cost control index and the schedule control index.</i>	61
4.1.8 Acebes, F., Pajares, J., Galán, J. M., & López-Paredes, A. (2014). <i>A new approach for project control under uncertainty. going back to the basics.</i>	65
4.1.9 Acebes, F., Pajares, J., Galán, J. M., & López-Paredes, A. (2015). <i>A Project Monitoring and control system using EVM and Monte Carlo Simulation.</i>	69
4.1.10 Acebes, F., Pereda, M., Poza, D., Pajares, J., & Galán, J. M. (2015). <i>Stochastic earned value analysis using Monte Carlo Simulation and Statistical Learning Techniques.</i>	69

4.1.11 Ballesteros-Pérez, P., Sanz-Ablanedo, E., Mora-Melià, D., González-Cruz, M. C., Fuentes-Bargues, J. L., & Pellicer, E. (2019). <i>Earned schedule Min-Max: Two new EVM metrics for monitoring and controlling projects.</i>	70
4.2 Bottom-up Project Control.....	75
4.2.1 Van Slyke, R. M. (1963). <i>Monte Carlo Methods and the PERT Problem.</i>	81
4.2.2 Williams, T. M. (1993). <i>Criticality in Stochastic Networks.</i>	82
4.2.3 Cho, J. G., & Yum, B. J. (1997). <i>An uncertainty importance measure of activities in Pert Networks.</i>	87
4.2.4 Gutierrez, G., & Paul, A. (1998). <i>Analysis of the effects of uncertainty, risk-pooling, and subcontracting mechanisms on project performance.</i>	92
4.2.5 Elmalghraby, S. E., Fathi, Y., & Taner, M. R. (1998). <i>On the sensitivity of project variability to activity mean duration.</i>	94
4.2.6 Elmaghraby, S. E. (2000). <i>On criticality and sensitivity in activity networks.</i>	98
4.2.7 - Vanhoucke, M. (2010). <i>Using activity sensitivity and network topology information to Monitor Project Time Performance.</i>	99
4.2.8 Madadi, M., & Iranmanesh, H. (2012). <i>A management oriented approach to reduce a project duration and its risk (variability).</i>	100
4.2.9 Ballesteros-Pérez, P., Cerezo-Narváez, A., Otero-Mateo, M., Pastor-Fernández, A., & Vanhoucke, M. (2019). <i>Performance comparison of activity sensitivity metrics in schedule risk analysis.</i>	104

4.3 A mixed approach: Elshaer, R. (2013). Impact of sensitivity information on the prediction of Project's duration using earned schedule method.....	106
4.4 Discussion.....	109
Conclusion	113
References.....	116

List of Tables

<i>Table 3.1 List of studies.....</i>	<i>38</i>
<i>Table 4.1. Notation.....</i>	<i>78</i>
<i>Table 4.2. Simulation runs results for sample project.....</i>	<i>80</i>
<i>Table 4.3. Significance Index calculations for activity 2</i>	<i>83</i>
<i>Table 4.4. Pearson's Cruciality Index calculations for activity 2</i>	<i>85</i>
<i>Table 4.5. Spearman's Cruciality Index calculations for activity 2</i>	<i>86</i>
<i>Table 4.6. Standard deviation calculations for all activities</i>	<i>103</i>

List of Figures

<i>Figure 1.1 The Project Management Triangle.....</i>	<i>12</i>
<i>Figure 1.2 Monitoring and Control as part of a feedback system</i>	<i>15</i>
<i>Figure 2.1 Possible arrangements of S-curves</i>	<i>21</i>
<i>Figure 2.2 AON Network with calculations.....</i>	<i>25</i>
<i>Figure 2.3 EVM Analysis Chart.....</i>	<i>30</i>

<i>Figure 4.1 Top-down and Bottom-up Project Control</i>	42
<i>Figure 4.2 Earned Schedule Components</i>	48
<i>Figure 4.3 EDM Components</i>	53
<i>Figure 4.4 Monte Carlo S-curve for Project Duration</i>	56
<i>Figure 4.5 Triangular Fuzzy Number</i>	58
<i>Figure 4.6 Different Conditions of Schedule Performance</i>	60
<i>Figure 4.7 Monte Carlo simulation results</i>	62
<i>Figure 4.8 Project Schedule Control Index evolution</i>	64
<i>Figure 4.9 Monte Carlo Simulation applied at the end of the project and at x% completion</i>	66
<i>Figure 4.10 Triad Framework during project execution</i>	67
<i>Figure 4.11 ES_{min} and ES_{max} calculation example</i>	73
<i>Figure 4.12 Schedule Risk Analysis four steps</i>	77
<i>Figure 4.13 Sample Project for indexes calculations</i>	80
<i>Figure 4.14 Effects on the project duration of variations in the duration of an activity</i>	89
<i>Figure 4.15 Interaction between activities durations example</i>	90
<i>Figure 4.16 Changes in project variance with changes in mean duration of activity (constant activity variance)</i>	95
<i>Figure 4.17 Changes in project variance with changes in mean duration of activity (constant activity coefficient of variation)</i>	97
<i>Figure 4.18 Taxonomy of sensitivity problems</i>	99
<i>Figure 4.19 Sub-networks of sample projects</i>	102

Introduction

In today's fiercely competitive and globalized world, companies craft their business vision and devise strategies to achieve short-, medium-, and long-term goals (Mayo-Alvarez et al., 2022). These strategies necessitate the formulation and proposal of projects, which are then prioritized, evaluated, approved, and, finally, executed. Consequently, the ultimate success of the overall strategy heavily relies on the successful implementation of these projects. However, defining and ensuring project success is the primary challenge project managers face. Typically, a project is considered technically successful if it effectively achieves its triple objectives: scope, time, and cost (Mayo-Alvarez et al., 2022). Therefore, managing and integrating these project constraints is of utmost importance. Indeed, project managers are required to conduct a comprehensive analysis and definition of such constraints from the early stages of a project, and as the project progresses, they must keep a close eye on its execution, continuously monitoring and maintaining control. Project managers can rely on several techniques to perform these activities, but the most popular among them is Earned Value Management.

EVM offers several advantages in project management. Indeed, it provides valuable forecasts and early warnings on project status, enabling timely corrective decisions to keep the project on track. Moreover, by clearly defining work scope and integrating technical, schedule, and cost performance, EVM ensures that project teams stay aligned, and that progress is communicated consistently at all management levels, enhancing project visibility and accountability while promoting efficient and effective project execution. However, as reported by Stone C. (2023), an estimated 70% percent of projects fail when using EVM, thus not meeting the established costs and time constraints. This is due to various limitations the methodology presents, in both time and cost monitoring.

The purpose of this paper is to delve into such limitations, reviewing the solutions proposed over the years to overcome them, with a specific focus on schedule monitoring and control. Indeed, while extensive research has been developed around the issue of cost monitoring and control, less attention has been paid to time tracking issues (Vanhoucke, 2011). Specifically, the paper introduces innovative solutions that target the key limitations of time performance indicators in Earned Value Management, uncovered through a detailed and extensive literature review.

The first chapter lays the groundwork by introducing the history and key principles of Project Management, with a special emphasis on the monitoring and control phase of a project.

The second chapter presents Earned Value Management (EVM) as the leading technique for this phase of project management. It offers an in-depth examination of the methodology, from the beginning of a project to its execution, and discusses the principal metrics utilized in EVM. The chapter concludes by outlining the main assumptions and constraints of EVM, particularly in relation to schedule monitoring and control.

The third chapter describes the methodology through which this literature review was conducted.

In the fourth chapter, various methodologies and solutions developed to address the shortcomings of EVM in time tracking are explored. This chapter is divided into three main sections, each discussing different methodologies grouped by the control approach they utilize. The first section delves into top-down project control approaches, including innovative metrics and techniques based on EVM. The second section explores various indices and studies related to bottom-up project control and Schedule Risk Analysis (SRA). The third section introduces a novel approach that amalgamates bottom-up and top-down project control methods to leverage the

strengths of both. The chapter concludes with a qualitative comparison of the studies reviewed, along with a discussion on the limitations of the results and methodology of this paper.

Chapter 1

Project Management

Project Management has been practiced since the very beginning of human history. However, it was not until the 20th century that organizations started applying systematic project management tools and techniques to complex projects. Indeed, although ancient civilizations unquestionably accomplished remarkable feats through careful planning and execution, exemplified by iconic structures like the Pyramids and the Coliseum, comprehensive documentation of the methodologies and techniques they employed is notably scarce. Yet, there is little agreement on when exactly modern Project Management began, as different authors offered different opinions on the matter. Undoubtedly, the first significant contributions to the field were made by Henry Fayol and Henry Gantt during the first two decades of the previous century. The former was an engineer in an iron and steel company who identified and defined, thanks to his experience and observation, what he believed were the five universal functions of management, i.e., planning, organizing, commanding, coordinating, and controlling. Despite being criticized over time, Fayol's five functions are still recognized as an initial but crucial overview of the main functions managers experience daily. On the other hand, Henry Gantt is best known for having developed the Gantt Chart right across the outbreak of World War I. This renowned tool proved to be quite effective since its first deployment and is still considered of vital importance for project managers today. Nevertheless, some authors, while acknowledging the significance of Fayol and Gantt, propose 1958 as the starting point for modern Project Management. Indeed, this is when the

Critical Path Method (CPM) and the Project Evaluation and Review Technique (PERT) were initially introduced, with the intent of providing a means to better illustrate the flow and sequence of the activities and events constituting a project. As someone might expect the little agreement on the past of the discipline is reflected and further expanded when trying to predict its future. Nonetheless, there is one undeniable truth: in every sector of the modern economy, from engineering and construction to finance and healthcare, Project Management is continuously evolving, thus gaining increasing importance for the functioning of our society.

1.1 Fundamentals of Project Management

To understand the concept of modern Project Management it is of primary importance to define what a project actually is, as the term in itself covers a wide range of possible interpretations and meanings. According to the Project Management Institute's (PMI) PMBOK® Guide 7th edition (2021), a project is “a temporary endeavor undertaken to create a unique product, service, or result”, where “the temporary nature of projects indicates a beginning and an end to the project work or a phase of the project work”. Therefore, it is evident that projects differ from a company's routine operations and that they should have definite starting and ending points (time), a budget (cost), and a clearly defined scope of work to be done (Heagney, J., 2016). The constraints of time, cost, and scope, also known as the triple constraints, are strongly interrelated and directly affect the quality of the project. Typically, to represent the relationship between such variables, authors and practitioners employ the so-called Project Management Triangle, shown in Figure 1.1.

Figure 1.1 The Project Management Triangle



The concept is quite simple: if a variable of the triple constraint is changed, the other two must be modified to keep the triangle connected, as if no adjustment is implemented the triangle “breaks”, i.e., the quality of the project is affected. To give an example, if the scope of a project is expanded, both time and cost should increase accordingly to allow the proper execution of the new and larger project without affecting the quality of its output. Project managers must therefore strike a balance between the triangle's three points in order to produce the best quality while delivering the expected project outcome. Indeed, it is commonly agreed that the primary responsibility of a project manager is to ensure that all work is completed on time, within budget and scope, and at the correct

performance level (Heagney, J., 2016). However, the PMBOK® Guide (2021) offers a more comprehensive characterization of the project manager, which is described as “the person assigned by the performing organization to lead the project team that is responsible for achieving the project objectives. Project managers perform a variety of functions, such as facilitating the project team work to achieve the outcomes and managing the processes to deliver intended outcomes”.

With the clear definitions of "project" and "project manager" established, the concept of Project Management becomes self-evident. In fact, according to the PMBOK® Guide (2021), Project Management is generally defined as “the application of knowledge, skills, tools, and techniques to project activities to meet project requirements. Project management refers to guiding the project work to deliver the intended outcomes.” However, given the intricate and expansive nature of Project Management, this definition alone proves insufficient. To address this, PMI further subdivided the discipline into eight performance domains and five group processes, creating a comprehensive framework that helps project managers effectively plan, execute, and control projects to meet their objectives. As defined in the PMBOK® (2021), project performance domains are interconnected and interdependent areas of interest that encompass a group of related activities essential for achieving the intended project results. Specifically, the eight performance domains are Stakeholders, Team, Development Approach and Life Cycle, Planning, Project Work, Delivery, Measurement, and Uncertainty. A comprehensive exploration of these domains falls outside the scope of this discussion. Therefore, interested readers are encouraged to delve deeper into this subject within the pages of the PMBOK® Guide for a more detailed examination. While the performance domains encompass the essential activities required to guarantee the successful delivery of project outcomes, the process groups provide a structured framework for organizing and managing these activities throughout the project's lifecycle. Particularly, the process groups

are five and can be described initially as follows (Project Management Institute, 2021, *A Guide to the Project Management Body of Knowledge*):

- Initiating. Those processes performed to define a new project or a new phase of an existing project by obtaining authorization to start the project or phase.
- Planning. Those processes required to establish the scope of the project, refine the objectives, and define the course of action required to attain the objectives that the project was undertaken to achieve.
- Executing. Those processes performed to complete the work defined in the project management plan to satisfy the project requirements.
- Monitoring and Controlling. Those processes required to track, review, and regulate the progress and performance of the project; identify any areas in which changes to the plan are required; and initiate the corresponding changes.
- Closing. Those processes performed to formally complete or close a project, phase, or contract.

However, given the purpose of this paper, a more detailed and comprehensive examination of the monitoring and controlling phase is provided in the following paragraph.

1.2 Monitoring and Controlling

As previously established, one of the main duties of project managers is to ensure that projects are completed in adherence to the triple constraints. Nevertheless, due to the inherent uncertainty of real-world endeavors, projects are rarely carried out precisely within the established budget and timeframe, making it necessary for managers to remain proactive throughout the project's lifecycle to minimize any potential deviations. This can be achieved through effective

project Monitoring and Controlling. Indeed, Monitoring and Control are two parts of a feedback system (displayed in Figure 1.2) aimed at detecting and correcting deviation from desired (De Marco, A., 2018), where detection is accomplished by monitoring, whereas correction is the goal of control activities.

Figure 1.2 Monitoring and Control as part of a feedback system

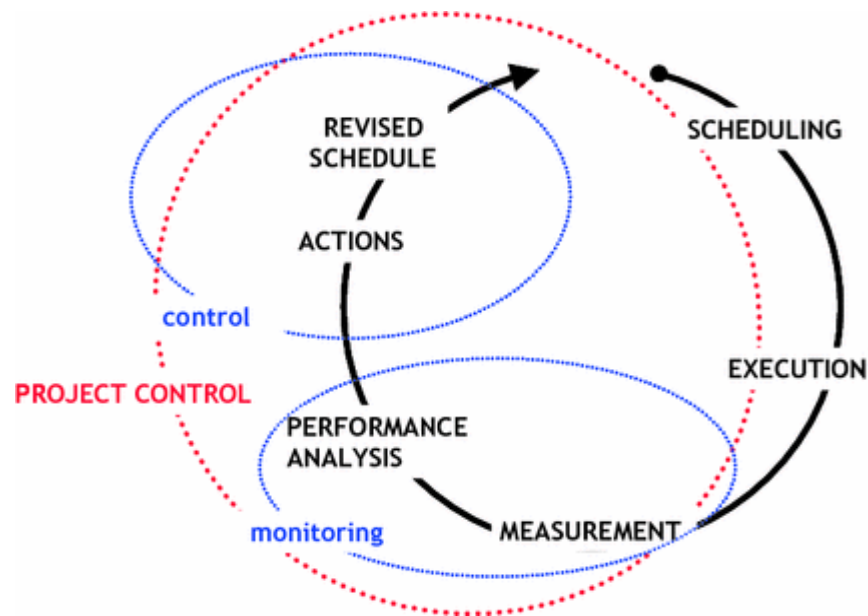

De Marco, A., 2018

In more detail, Monitoring can be defined as the set of procedures and management practices used to collect information about the performance achieved or forecasted in a project, based on a set of performance metrics (De Marco, A., 2018). Therefore, one of the first steps managers must undertake to implement an effective Monitoring system is to define these metrics during the planning phase. However, in order to measure the actual performance against the expected, it is also necessary to clearly establish cost and time baselines for the project. Typically, this is achieved through the creation of a Project Work Breakdown Structure (WBS), which subsequently forms the basis for project scheduling and Cost Breakdown Structure (CBS)

development. The WBS is a hierarchical decomposition of the total scope of work to be carried out by the project team to accomplish the project objectives and create the required deliverables (Project Management Institute, 2021, *A Guide to the Project Management Body of Knowledge*). Once the WBS is defined, managers can determine the duration and sequencing of its components, effectively creating the project schedule. In parallel, cost forecasts for various WBS elements are established, leading to the definition of the CBS. Together, these elements provide managers with the foundation for successfully conducting the monitoring process throughout the project execution phase. Indeed, by continuously comparing actual costs and schedule progress to the established baseline through the established performance metrics, managers gain real-time insights into the project's status, enabling them to take corrective action when deviations occur. Over the years, numerous approaches and methodologies have been developed for this purpose. Nevertheless, one method that garnered widespread use and acclaim among practitioners is the Earned Value Methodology (EVM), which will be deeply discussed in the following chapters.

As depicted in Figure 1.2, once the performance analysis is complete, the control process comes into play. Essentially, control is the mechanism that ensures the project aligns with its initial objectives by pinpointing the root causes of any performance discrepancies, making necessary adjustments, and implementing them through specific control actions. Therefore, whether it's about recalibrating the project to its original trajectory or proactively mitigating potential challenges, control acts as the guiding hand ensuring the project remains on its intended course.

In conclusion, the Monitoring and Control process is indispensable for the efficient management of projects. In fact, it not only ensures the achievement of project objectives but also actively manages the project's alignment with stakeholders' expectations, budget constraints, and

scheduled timelines, thus playing a pivotal role in steering the project toward successful completion and adaptability in dynamic project environments.

Chapter 2

Earned Value Management

The concept of monitoring and controlling project work has a rich history, with sophisticated systems existing long before the emergence of modern project management in the 20th century. The development of project controls began with static representations of deterministic data and has evolved in the past century to use deterministic information to predict future outcomes. This evolution phase started in the late 1950s with PERT and CPM schedules and has progressed through, to the point where there is general acceptance that Earned Value and Earned Schedule are among the best predictive control tools (Weaver, P., 2022).

In particular, the origins of Earned Value Management (EVM) can be traced back to the early 1960s, when the United States Department of Defense (DoD) first employed the PERT and CPM techniques to address the challenges of managing large and complex projects. Although these tools signified an important step forward in effective project monitoring and control, managers soon realized that they were not improving project performance measurements, and more importantly, Estimates at Completion (EACs). This led to the development between 1965 and 1966 of the Cost/Schedule Planning and Control Specification (C/SPCS or C-Spec) by the U.S. Air Force. C/SPCS was a significant advancement, introducing concepts like Planned Value of Work Scheduled (PVWS) and Planned Value of Work Accomplished (PVWA). Indeed, the Department of Defense (DoD) swiftly acknowledged the benefits of this strategy and deemed it necessary to

expand it to a DoD-wide requirement, culminating in the establishment of the Cost/Schedule Control Systems Criteria (C/SCSC) through the issuance of Department of Defense Instruction (DoDI) 7000.2, Performance Measurement for Selected Acquisitions, on December 22nd, 1967 (Weaver, P., 2022). Throughout the subsequent decades, the principles of C/SCSC were widely adopted and adapted by various organizations, both within and outside the defense sector. However, as projects grew in complexity and spanned across various industries, the high bureaucracy associated with C/SCSC led to calls for a more streamlined and standardized approach. It was only in the mid-1990s, under the initiative of the National Defense Industrial Association (NDIA), that efforts were made to reengineer the C/SCSC criteria. The outcome was a more straightforward set of guidelines, which laid the foundation for the modern Earned Value Management System (EVMS). Finally, this refined approach was formally adopted as the American National Standards Institute/Electronic Industries Alliance (ANSI/EIA) Standard 748 in July 1998, representing a culmination of decades of evolution in EVM practices. Indeed, in addition to validating its fundamental ideas, the ANSI/EIA Standard 748's acceptance of EVM techniques also marked a turning point in the evolution of EVM from a specialized defensive tool to a widely respected standard for project management excellence.

Obviously, while 1998 marked a significant milestone in the history of EVM, its evolution didn't halt there, and over the years numerous refinements and alternatives were proposed. Among them, one of the most accredited is undoubtedly the introduction of the Earned Schedule (ES) technique in 2003, aimed at addressing the limitations of classic EVM in predicting time performance as projects near completion.

2.1 Fundamentals of EVM

Earned Value Management (EVM) is the most popular management methodology used to monitor and measure project performance. In its *Standard for Earned Value Management* (2019), PMI defined Earned Value Management (EVM) as “a methodology for integrating scope, schedule, and resources; for objectively measuring project performance and progress; and for forecasting project outcome.” This methodology is based on the principle that past patterns and trends can indicate future conditions, clearly showing where a project is headed compared to where it is supposed to be. Therefore, through the employment of EVM, managers can easily keep track of progress, costs, and schedule, ensuring the project stays on the right track and achieves its objectives smoothly. As previously stated, over the years a multitude of enhancements and variations to traditional EVM metrics have been proposed in the literature to address both its general and industry-specific limitations. Nevertheless, regardless of their focus, all EVM analyses are based on three key data measures, which are Planned Value (PV), Earned Value (EV), and Actual Cost (AC):

- The Planned Value (PV), also known as the Budgeted Cost of Work Scheduled (BCWS), refers to the authorized budget for the work scheduled to be accomplished in a given time frame. In other words, it represents the value of the work planned to be completed up to a specific point in the project schedule. The total cumulative PV is known as Budget At Completion (BAC) and represents the total budgeted cost of the entire project as initially planned and approved at the outset.
- The Actual Cost (AC), also known as the Actual Cost of Work Performed (ACWP), represents the total cost incurred in completing the work actually performed up to a specific point in the project schedule, including labor, materials, equipment, etc. Therefore, AC is

a real-time reflection of the financial resources employed during project execution, essential to provide all stakeholders with a clear picture of the current investment in the initiative relative to the work that has been accomplished.

- The Earned Value (EV), also known as the Budgeted Cost of Work Performed (BCWP), represents the budgeted value of the work accomplished at a specific point in time during the project's execution. In simpler terms, while the budget might allocate a certain amount for a task, the EV tells us how much of that budgeted amount has been "earned" by actual work completion. Therefore, by utilizing monetary measures, the EV serves as a comprehensive metric, gauging a project's cost and time performance based on the value of work completed relative to its budgeted cost and scheduled value.

2.2 S-Curves

S-curves can be used to graphically represent the three parameters of Planned Value (PV), Earned Value (EV), and Actual Cost (AC) in earned value analysis. This graphic representation makes their dynamics easier to understand and provides a quick snapshot of the project's progress throughout its lifecycle. In particular, these curves consist of a mathematical representation of the cumulative values of PV, EV, and AC, with the x-axis representing time and the y-axis showing costs. S-curves are so named due to the typical S shape of these parameters' cumulative functions when plotted on a graph. While the S-curve for the PV can be drawn already at the beginning of the project, the EV and AC curves are gradually formed as the project progresses. The graphical representation of the EVM metrics is beneficial for gaining general insights into the project status by comparing the relative position of each curve on the graph. For a visual representation of these scenarios, refer to Figure 3 below, which displays all possible arrangements of these metrics (note: in Figure 3 AC is referred to as AV). For instance, if the EV is lower than PV at a given point in

time (as shown in scenarios A1, A2, and B2 in Figure 2.1), managers can immediately understand they are falling behind schedule, as the value the project has achieved by then is lower than projected. Moreover, by comparing the AC with the EV, it is possible to determine whether the project is going under or over budget. For example, if AC is lower than EV (as shown in scenarios B2, C1, and C2 in Figure 2.1), the amount spent to reach that point of the project is lower than forecasted, implying that the project is under budget. Obviously, such considerations would be the opposite in the case EV was greater than PV and AC than EV. Even though the graphical visualization offers a first practical look at the project status, defining quantitative metrics to assess the magnitude of such variations is necessary to thoroughly evaluate project progress and adequately address issues whenever these may arise. The first step to do so is conducting a variance analysis, which will be discussed in the following paragraphs.

Figure 2.1 Possible arrangements of S-curves

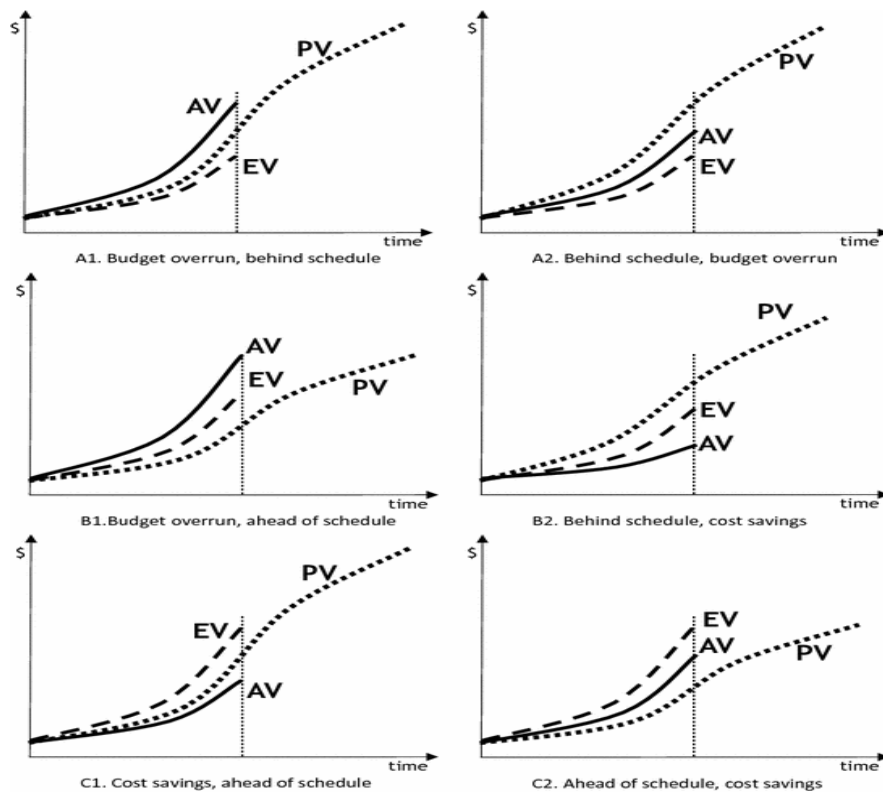

De Marco, A., 2018

2.2.1 From the Project Plan to the Planned Value Curve

In Earned Value Management (EVM), the foundation for assessing project performance is the Planned Value Curve, also known as the Performance Measurement Baseline (PMB), representing the anticipated cost and progress throughout the project's lifecycle. The curve, in turn, is deeply rooted in the project's planning phase. Therefore, to establish a strong and reliable foundation for EVM implementation, it is essential to have a well-crafted project plan, mainly focusing on the scope statement and related Work Breakdown Structure (WBS). Indeed, the project plan provides managers with a documented basis for making future project decisions and for confirming or developing a common understanding of project scope among the stakeholders, i.e., the scope statement, along with a hierarchical decomposition of the work to be executed by the project team to accomplish the project objectives and create the required deliverables, i.e., the WBS (Reichel, C. W., 2006). Given its significance, the project plan becomes the essence upon which the PMB is built, thus directly influencing the quality and reliability of a project's monitoring and controlling processes and, as a result, its successful implementation. However, in order to craft the PV curve additional steps are essential for managers to undertake. Indeed, once the scope has been defined and broken down into manageable parts through the WBS, it is still necessary to perform the scheduling and budgeting phases.

Scheduling involves identifying specific activities linked to the WBS deliverables, understanding their interdependencies, and estimating their durations. Dependencies are oftentimes expressed in terms of predecessors, meaning tasks that need completion before subsequent activities can begin, and are vital for establishing the logical order of the work that must be accomplished. Obviously, there is no fixed mathematical formula or rule dictating this sequence, and predecessors usually arise from technical necessities, e.g., a house roof is built after

its walls, or from organizational factors such as company policies or resource availability. Along with the dependencies, it is necessary to estimate the duration of each activity in order to obtain a time-phased schedule that allows for proper project tracking. Once activities, dependencies, and durations are established, the logical flow of the work sequence can be graphically illustrated, typically through an Activity-On-Arrow (AOA) network (see Figure 2.2) showing the planned start/finish dates for activities, schedule duration, and float values for the individual activities on the project. However, before delving into the intricacies of calculating planned start/finish dates, schedule duration, and float values, it's crucial to grasp some fundamental scheduling terms, as elucidated by Kramer and Jenkins (2006):

- Early Start (ES): The earliest date the activity can start
- Early Finish (EF): The earliest date that the activity can finish
- Late Finish (LF): The latest date that the activity can finish without causing a delay to the project completion date.
- Late Start (LS): The latest date that the activity can start without causing a delay to the project completion date.
- Free Float (FF): The maximum number of days the activity can be delayed without delaying any succeeding activity, computed as

$$FF = \text{Lowest ES of successors} - EF \quad (1)$$

- Total Float (TF): The maximum number of days the activity can be delayed without delaying the project completion date, computed as

$$TF = LS - ES \quad (2)$$

- Critical Activity: Any activity in the schedule that does not possess any float; Total Float=0
- Critical Path: The continuous string(s) of critical activities in the schedule between the Start and Finish of the project. The sum of the activity durations in the Critical Path is equal to the Project's Duration; therefore, a delay in any Critical Activity will result in a delay in the Project Completion Date.

An example of such calculations on an AON network is shown in Figure 4. The ES of each activity is determined by the maximum EF value from predecessors, starting from day 0 with activity A, while the EF is simply the ES plus the activity duration. Analogously, the LF of each activity is the minimum LS value from successors, and the LS is computed as the LF minus the activity duration. Finally, the TF and FF can be determined using the aforementioned formulae (1) and (2). In the example provided, the critical path comprises the critical activities A, B, D, and F, culminating in a project duration of 16 days. This duration corresponds to the combined total of the four activities and matches the Early Finish of activity F, which also aligns with its Late Finish due to its zero float.

Figure 2.2 AON Network with calculations

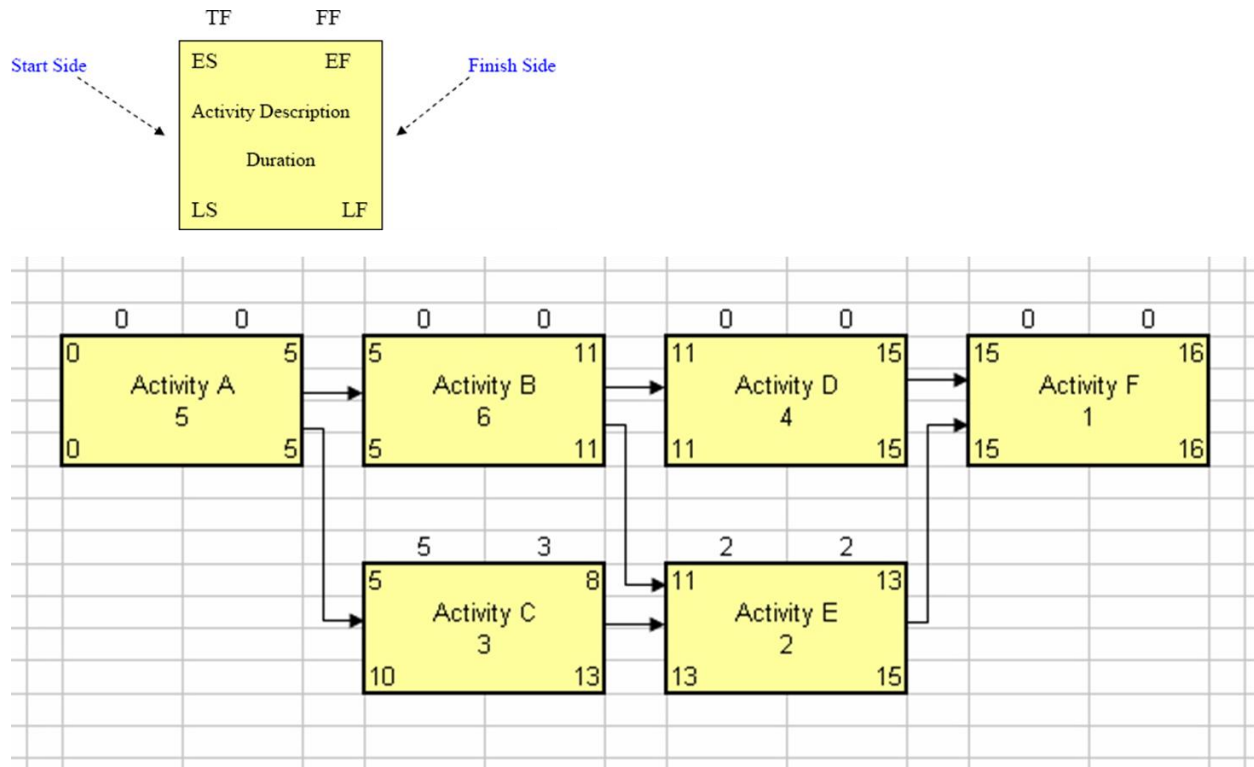

Kramer, S. W. & Jenkins, J. L., 2006

Alongside scheduling, managers are tasked with forecasting the costs associated with each activity. This forms the project's budget, which is the aggregate of the anticipated costs for all scheduled tasks. The methodologies used to estimate the time and cost for project activities are not discussed in this paper, but extensive literature can be found on the topic.

Upon finalizing the schedule and budget, the Planned Value (PV) can be ascertained. For each time unit, commonly measured in days, the cost associated with the activities scheduled during that period is calculated, i.e., its PV. To estimate this cost, the total expense of an activity is typically divided by its duration, providing a linear approximation of the cost per time unit. Whereupon, by accumulating these values over time, a curve that represents the cumulative

Planned Value at each point in time emerges. This curve, known as the PV curve, serves as a pivotal tool for monitoring the project's progress throughout its execution, as previously discussed.

2.3 EVM Metrics

In Earned Value Management (EVM), metrics play a pivotal role in assessing the performance and progress of a project. These metrics, derived from the project's planning and execution data, provide quantifiable insights into how well the project is adhering to its planned schedule and budget. Therefore, they serve as the bridge between the project's planned objectives and its actual performance, offering a clear picture of any discrepancies. Furthermore, by analyzing past variances and understanding their root causes, project managers can anticipate potential future deviations and formulate strategies to mitigate them, thus ensuring that projects remain aligned with their initial objectives even when unforeseen challenges arise.

2.3.1 Variance Analysis

PMI's PMBOK® Guide defines a variance as “a quantifiable deviation, departure, or divergence away from a known baseline or expected value.”. In the context of EVM, two primary variance metrics are used:

- **Schedule Variance (SV):** This metric is computed as the difference between Earned Value (EV) and Planned Value (PV). It provides a monetary representation of the deviation between the actual work achieved and what was initially planned for that period.

$$SV = EV - PV \quad (3)$$

- **Cost Variance (CV):** CV is determined by the difference between EV and Actual Cost (AC). It indicates the monetary difference between the value of work achieved and the actual costs incurred.

$$CV = EV - AC \quad (4)$$

The interpretation of these metrics is straightforward:

- When both SV and CV are zero, it signifies that the project is perfectly on track concerning its schedule and budget.
- Positive SV values indicate that more work has been completed than was planned for that period, suggesting the project is ahead of schedule. Conversely, negative SV values indicate a delay.
- Positive CV values suggest that the project is under budget, as the value of work achieved exceeds the actual costs incurred. In contrast, negative CV values indicate cost overruns.

To give an example, consider a project with a Planned Value of \$100,000 by the end of the first quarter. If, by that time, the Earned Value is \$90,000 and the Actual Cost is \$95,000, the SV would be -\$10,000 and the CV would be -\$5,000, indicating that the project is falling both over budget and behind schedule.

2.3.2 Performance Indexes

The EVM analysis continues by introducing performance metrics, the Cost Performance Index (CPI), and the Schedule Performance Index (SPI). Indeed, while variances provide absolute values indicating deviations from the plan, they might not always communicate the extent and significance of the discrepancy. Performance indexes, on the other hand, enable project managers to assess the magnitude of these deviations, thus better evaluating the project's development in regard to its intended goals and making more informed decisions.

- Schedule Performance Index (SPI): PMI's PMBOK® Guide (2021) defines the SPI as “an earned value management measure that indicates how efficiently the scheduled work is

being performed”. Therefore, the SPI measures how efficiently the project team is utilizing time, and is computed by taking the ratio of the Earned Value (EV) to the Planned Value (PV).

$$\text{SPI} = \text{EV} / \text{PV} \quad (5)$$

- Cost Performance Index (CPI): Similarly to SPI, the CPI is defined as “an earned value management measure that indicates how efficiently the work is being performed with regard to the budgeted cost of the work” (Project Management Institute, 2021, *A Guide to the Project Management Body of Knowledge*). The CPI represents the value obtained for each unit of cost spent and is determined by comparing the Earned Value (EV) to the Actual Cost (AC) incurred.

$$\text{CPI} = \text{EV} / \text{AC} \quad (6)$$

As with variances, the interpretation of these performance indexes is easily deductible. When the value of either index is 1, it indicates that the project is perfectly aligned with its planned cost or schedule. On the other hand, a value greater than 1 for CPI suggests cost efficiency, meaning the project is getting more value than what it's spending. Analogously, an SPI greater than 1 indicates that the project is ahead of its planned schedule. It follows that values less than 1 for either index highlight inefficiencies, with CPI values below 1 indicating cost overruns and SPI values below 1 suggesting delays in the project schedule. Overall, these metrics offer project managers a more detailed understanding of how the project deviates from its initial plan. Moreover, they can be utilized to calculate the project's expected total cost and duration at any given point during its execution, i.e., the Estimate At Completion (EAC) and Time Estimate at Completion (TEAC):

- Estimate At Completion (EAC): This metric provides a forecast of the expected total cost of the project upon completion given its current performance, thus offering a revised estimate that can be compared to the original budget to anticipate potential overruns or savings. Specifically, EAC is computed as the ratio of the Budget at Completion (BAC) to the CPI.

$$EAC = BAC / CPI \quad (7)$$

- Time Estimate at Completion (TEAC): The TEAC is computed as the ratio of Planned Duration (PD), i.e., the estimated duration of the project obtained during the planning phase, to SPI. This metric is used to predict the actual time needed to complete the initiative based on its current schedule performance, thus helping managers adjust timelines and set realistic completion dates.

$$TEAC = PD / SPI \quad (8)$$

Overall, these metrics offer project managers a more detailed understanding of how the project deviates from its initial plan. A chart showing a typical EVM analysis chart is shown in Figure 2.3.

Figure 2.3 EVM Analysis Chart

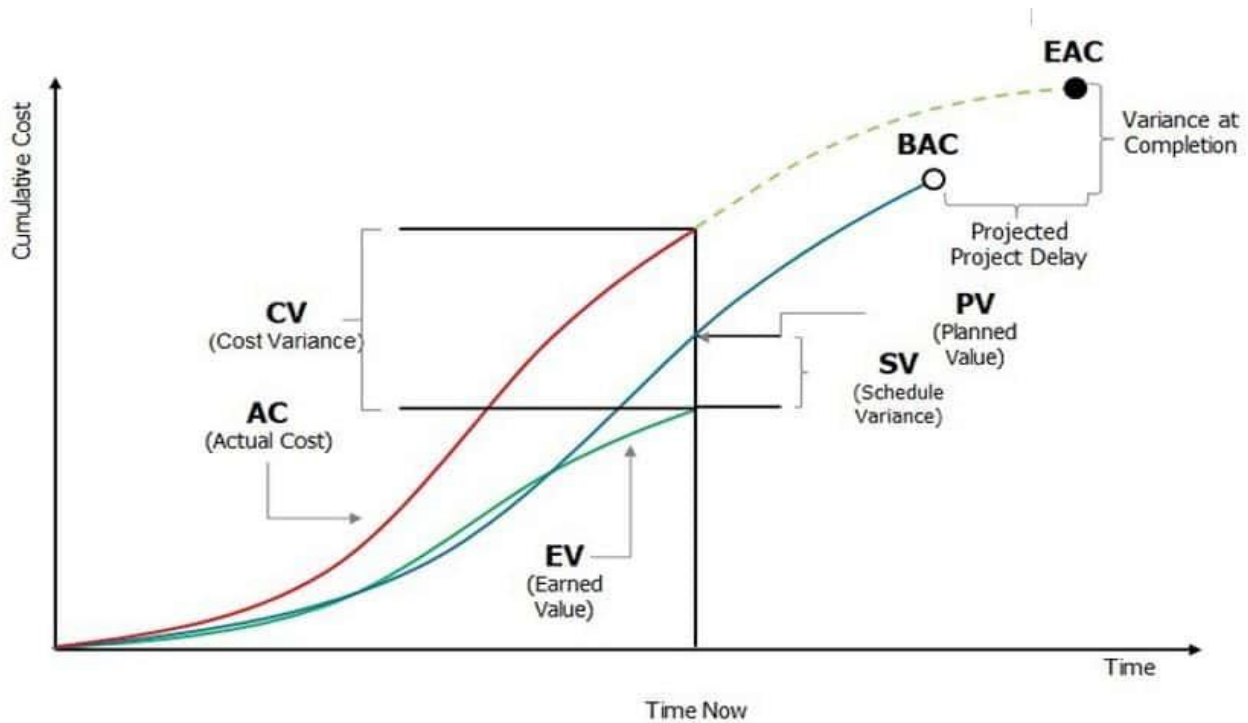

Reichel, C. W., 2006

Last but not least, in addition to the well-established performance metrics such as the Cost Performance Index (CPI) and the Schedule Performance Index (SPI), researchers introduced the To Complete Performance Index (TCPI) as a further tool in earned value management (EVM). The reason for such an implementation was dictated by the need to offer a forward-looking perspective compared to CPI and SPI, which primarily gauge past and present performance by retrospectively measuring cost and schedule efficiency. Indeed, the purpose of this metric is to provide a projection of cost performance that a project must achieve on the value of the remainder of the project work to achieve the BAC (Scott, W. J., 2012).

Specifically, the TCPI is computed as the ratio of the value of the remaining work ($BAC - EV$) to the amount of funds remaining ($BAC - AC$):

$$\text{TCPI} = (\text{BAC} - \text{EV}) / (\text{BAC} - \text{AC}) \quad (9)$$

A TCPI greater than one indicates that the remaining funds will not suffice to complete the project within the approved budget and that the overall cost efficiency must increase to meet the initial project constraints. To calculate the increase in efficiency required, it is necessary to assess the difference between the TCPI and CPI of the project. For example, if the project presents a CPI equal to 0.9 and a TCPI equal to 1.04, project managers must increase the cost efficiency by 0.14 (TCPI – CPI), or better, by 14%. Overall, when compared to the previous EVM metrics mainly focused on past or current project performance, the TCPI enables a forward-looking perspective that empowers managers with greater control over the project, allowing early detection and addressing of potential issues and, subsequently, helping them steer their projects towards successful completion.

2.4 EVM Limitations in Schedule Monitoring

EVM proved to be a source of several advantages in project management. Firstly, it provides forecasts and early warnings on the potential evolution of the project status in terms of cost, schedule, and scope, thus allowing managers to make timely corrective decisions. Moreover, EVM is claimed to be able to generally improve the planning process, foster a clear definition of work scope, integrate technical, schedule, and cost performance, identify problem areas for immediate and proactive management action, provide consistent and clear communication of progress at all management levels, and improve project visibility and accountability. Nonetheless, EVM is not without its limitations. One of its significant drawbacks is its reliance on the assumption that future performance can be predicted based on past performance (Hillson, D., 2014). However, there is no guarantee that such an assumption will be true; instead, it is more likely that the future will deviate from that predicted as the methodology's purpose itself is to

extrapolate from past performance and take corrective actions accordingly. In addition to being affected by the actions deliberately taken by management, the remaining elements of the project are also subject to risk, both positive opportunity and negative threat, introducing variation and ambiguity into future performance (Hillson, D., 2014). Another strong limitation of the methodology emerges from the assumption that the duration and cost of each task are considered deterministic. As Nizam A. et al. (2019) pointed out, the deterministic nature of EVM does not provide a range of possible outcomes or the probability of meeting project objectives. And this lack of probabilistic information can have significant consequences for project planning and decision-making. Indeed, in real-world project environments, uncertainties are omnipresent, and tasks are rarely executed exactly as planned. Various factors, such as unexpected technical challenges, changes in requirements, resource availability, and external market conditions, can all impact the duration and cost of individual tasks. Therefore, by assuming that these factors are deterministic, the methodology overlooks the inherent unpredictability in project execution. Furthermore, without a probabilistic range of outcomes, project managers and stakeholders are essentially basing their decisions on a single, exact scenario with an extremely low probability of materializing precisely as predicted, thus exposing the project team and the project itself to unnecessary risks.

While these limitations are applicable to both time and cost monitoring and control, their impact on these two dimensions is not equal. Indeed, nowadays it is accepted that EVM is more accurate in the cost dimension than in the time dimension (Ballesteros-Pérez, P., Sanz-Ablanedo, E., Mora-Melià, D., González-Cruz, M. C., Fuentes-Bargues, J. L., & Pellicer, E. (2019). This is due to the several factors characterizing EVM and its underlying assumptions, which hinder its ability to effectively grasp the fundamental characteristics of project schedules. One notable

critique directed at the EVM model pertains to its measurement of time performance metrics using value-based criteria (Borges, W. F., & Mário, P. do., 2017). As previously discussed, in fact, the definition of SV is associated with the difference between two monetary values. However, although correlations between a project's duration and cost patterns may exist, discrepancies between these structures can lead to reduced accuracy in schedule evaluation, particularly when the gap between time and cost widens (e.g., an activity incurring high costs but having a relatively short duration). Furthermore, EVM is found to be unreliable in estimating time at completion (TEAC), both at the project's outset and during its execution. This unreliability stems from EVM's failure to account for variability and uncertainty in activity durations. Instead, it simply calculates the project's total duration as the sum of critical activities, resulting in overly optimistic initial estimates (Vanhoucke, M., 2011). This outcome is expected since, unlike the project's total cost, which primarily derives from the aggregation of activity costs, the project's total duration depends entirely on the interdependencies among activities and their specific sequence of execution. Moreover, the SV and SPI metrics have an inherent flaw in measuring time performance during project execution. Due to their calculation methods, as the project nears completion, they invariably get closer to 1, thus not being reliable to assess time performance and to predict TEAC in these stages of the project (Lipke, W., 2003). Another limitation of the methodology is its inability to account for the impact of non-critical activities, potentially signaling false alarms and leading to taking wrong corrective actions (Vanhoucke, M., 2011). To give an example, a delay in a non-critical activity might erroneously signal that the project is in trouble, even if there is no real issue because the activity still has some float left. Finally, EVM does not excel in parallel networks (Vanhoucke, M., 2010). Indeed, in cases where networks primarily consist of serial activities or include parallel non-critical activities with negligible durations compared to critical ones, the effect

of variability in activity durations is less pronounced. However, as the network adopts a more parallel structure, variations in activity durations may lead to the possible realization of several critical paths. Consequently, a non-critical activity may become critical, and EVM can no longer identify the root cause of delays. This limitation arises because EVM takes a broad perspective of the project, does not consider uncertainty, and assumes that attention should be paid exclusively to those activities that are defined as critical in a deterministic project network. Therefore, for projects featuring parallel activities with similar durations, the concept of a single critical path loses significance, and analyzing the project at the activity level becomes imperative to ensure its successful execution.

Chapter 3

Methodology

The primary objective of this research is to explore the limitations of Earned Value Management (EVM) in schedule monitoring and control and propose viable solutions to these limitations. To achieve this objective, a literature review methodology was employed. This methodology was chosen for its ability to provide a comprehensive and unbiased overview of the existing literature on EVM, its limitations, and potential solutions.

In the execution of this literature review, a stringent and meticulous methodology was employed to ensure the inclusion of only the most pertinent and credible sources. To achieve this, the PRISMA framework for literature review reporting was followed. The focus was primarily on published research studies and articles that pertained to project management, all of which were written in standard English. To maintain the integrity and reliability of the review, any unpublished

material was deliberately excluded. The studies incorporated into this review were meticulously selected based on their clear descriptions of datasets, methodologies, and the detailed specification of the algorithms and procedures utilized, and only articles that were relevant, clear, and contributed to the understanding of the topic were included. Specifically, this was accomplished by following specific selection criteria. Throughout the research, only articles directly related to project schedule control, including topics such as scheduling techniques, tools, methodologies, and best practices, and published in reputable peer-reviewed journals or presented at well-established conferences to ensure academic rigor were included. Additionally, it was ensured that all articles selected were written in clear and accessible language, avoiding overly complex models or concepts that may require extensive explanations, and particular attention was paid to those that offered practical insights and solutions that can be applied in real-world project management scenarios. Overall, the studies have been selected with the final aim of providing a thorough and understandable overview of the techniques and systems presented. The list of studies analyzed can be found at the end of this chapter in Table 3.1.

The exploration of relevant sources was carried out using various academic search platforms, such as Google Scholar, ScienceDirect, ResearchGate, and PMI. This was achieved by employing a set of pertinent keywords, including 'EVM', 'EVM limitations', 'EVM effectiveness', 'project scheduling efficiency', 'EVM in project management', 'schedule performance analysis', and 'project schedule control'. Additionally, the process involved identifying studies through the method of citation searching.

The articles and respective models included are thoroughly discussed in the following chapter. They are divided into two main groups, each of which is presented with a different approach. In the former, articles are shown following a thematic approach, based on common

themes or topics that emerge from literature. This choice was taken as within this group two sub-categories were identified, addressing different limitations of EVM in project schedule control. The latter group, conversely, follows a chronological order, as the methodologies analyzed are subsequent refinements and advancements of previous ones.

The screening and collection process, a critical phase in this research, was diligently overseen by the author. A meticulous approach characterized this endeavor, with a strong emphasis on precision and thoroughness. Research materials were systematically obtained through the search method outlined earlier in this document. Furthermore, a rigorous validation process was enacted, involving the cross-referencing of information acquired from these sources with other pertinent studies already incorporated into this research, where applicable. In ensuring transparency and adherence to strict criteria for source inclusion, the author employed a systematic approach that aimed to deliver a comprehensive and reliable foundation for the subsequent research analysis. Throughout this process, the author considered factors such as resource accessibility, leveraging the expertise of collaborators, and ensuring the highest standards of data quality assessment and ethical compliance. These considerations underscore the commitment to producing a robust and credible body of research.

In the research, the following biases were identified: sampling bias, selection bias, and expectancy bias. Addressing these biases was a critical aspect of the research process, with the guidance and support of the relator and co-relator playing a pivotal role in navigating these challenges.

Sampling Bias includes retrieval and publication biases. Retrieval bias occurs when the articles sampled are based on inadequate or incomplete searches (Durach, C. F., Kembro, J., & Wieland, A., 2017). This bias can lead to a sample of primary studies that is not representative of

the available literature base, potentially affecting the comprehensiveness and validity of the review. To counteract this bias, extensive and meticulous searches were conducted, guided by the expertise and advice of the relator and co-relator. This ensured an exhaustive and accurate literature search, encompassing a variety of databases and sources to guarantee extensive coverage of the literature. Publication bias, on the other hand, refers to the tendency of journals to publish findings that challenge or change existing knowledge, while less frequently publishing studies that confirm previous results (Durach, C. F., Kembro, J., & Wieland, A., 2017). This bias can skew the literature review towards more novel or controversial findings, potentially overlooking important confirmatory studies. To mitigate publication bias, editorial policies of journals were considered during the selection process, focusing on those that advocate for publishing high-quality studies regardless of their results.

Selection Bias is comprised of inclusion criteria bias and selector bias. Inclusion criteria bias arises from the inaccurate design of selection criteria, which can lead to relevant literature being excluded and the development of incorrect results (Durach, C. F., Kembro, J., & Wieland, A., 2017). This challenge was tackled by establishing clear and objective criteria for including and excluding studies from the review, with regular consultations with the relator and co-relator to ensure accuracy and transparency. Selector bias occurs when researchers subjectively include studies, influenced by their perceptions regarding the results, authors, or journals (Durach, C. F., Kembro, J., & Wieland, A., 2017). This bias can result in an incomplete or even incorrect subset of relevant literature. To reduce selector bias, multiple researchers were involved in the selection process, and a blind process was followed where possible.

Expectancy Bias occurs during the synthesis of study data, where the researchers' conscious or unconscious expectations about the results influence the synthesis (Durach, C. F.,

Kembro, J., & Wieland, A., 2017). This bias can make the synthesis of study data subjective, leading to incorrect outcomes of the review. To address expectancy bias, parallel and blind syntheses involving multiple researchers were conducted. This approach helps to ensure that the synthesis is not overly influenced by any single researcher's expectations or preconceptions, leading to a more balanced and objective review.

Given the nature of this review, which is primarily a synthesis and presentation of existing literature studies, a planned synthesis and sensitivity analysis was deemed neither appropriate nor necessary. This is because the review does not involve designing and applying algorithms to a common dataset to evaluate the accuracy of different techniques. Instead, it focuses on presenting and analyzing the findings of existing studies in the context of the research objectives.

Table 3.1 List of studies

Title	Author(s)	Year
Monte Carlo Methods and the PERT Problem	Van Slyke, R. M.	1963
Criticality in Stochastic Networks	Williams, T. M	1993
An uncertainty importance measure of activities in Pert Networks	Cho, J. G., & Yum, B. J.	1997
On the sensitivity of project variability to activity mean duration	Elmalghraby, S. E., Fathi, Y., & Taner, M. R.	1998
Analysis of the effects of uncertainty, risk-pooling, and subcontracting mechanisms on project performance.	Gutierrez, G., & Paul, A.	1998

On criticality and sensitivity in activity networks.	Elmaghraby, S. E.	2000
Earned value project management method and extensions	Anbari, F. T.	2003
Forecasting project schedule completion with earned value metrics.	Jacob, D.	2003
Schedule is different.	Lipke, W.	2003
A simulation and evaluation of Earned Value Metrics to forecast the project duration.	Vanhoucke, M, & Vandevoorde, S.	2007
Designing a control mechanism using earned value analysis: An application to production environment	Bagherpour, M., Zareei, A., Noori, S., & Heydari, M.	2009
Forecasting a Project's Duration under Various Topological Structures.	Vanhoucke, M., & Vandevoorde, S.	2009
Analysis of Project Performance of a Real Case Study and Assessment of Earned Value and Earned Schedule Techniques for the Prediction of Project Completion Date.	Tzaveas, T., Katsavounis, S., Kalfakakou, G.	2010
Using activity sensitivity and network topology information to Monitor Project Time Performance	Vanhoucke, M.	2010
An extension of the EVM analysis for Project Monitoring: The cost control index and the schedule control index.	Pajares, J., & López-Paredes, A.	2011

On the dynamic use of Project Performance and schedule risk information during project tracking.	Vanhoucke, M.	2011
A management oriented approach to reduce a project duration and its risk (variability).	Madadi, M., & Iranmanesh, H.	2012
Impact of sensitivity information on the prediction of Project's duration using earned schedule method.	Elshaer, R.	2013
A new approach for project control under uncertainty. going back to the basics.	Acebes, F., Pajares, J., Galán, J. M., & López-Paredes, A.	2014
How risky is your project — And what are you doing about it?	Hillson, D.	2014
EDM: Earned duration management, a new approach to schedule performance management and measurement.	Khamooshi, H., & Golafshani, H.	2014
A Project Monitoring and control system using EVM and Monte Carlo Simulation	Acebes, F., Pajares, J., Galán, J. M., & López-Paredes, A	2015
Stochastic earned value analysis using Monte Carlo Simulation and Statistical Learning Techniques.	Acebes, F., Pereda, M., Poza, D., Pajares, J., & Galán, J. M.	2015
Performance comparison of activity sensitivity metrics in schedule risk analysis.	Ballesteros-Pérez, P., Cerezo-Narváez, A., Otero-Mateo, M., Pastor-Fernández, A., & Vanhoucke, M.	2019

Earned schedule Min-Max: Two new EVM metrics for monitoring and controlling projects.	Ballesteros-Pérez, P., Sanz-Ablanedo, E., Mora-Melià, D., González-Cruz, M. C., Fuentes-Bargues, J. L., & Pellicer, E.	2019
---	--	------

Chapter 4

Results

As previously discussed, although EVM is the most popular tool among practitioners due to its simplicity and broad applicability, it presents several downfalls, especially when it comes to schedule monitoring. In this chapter, numerous alternatives to classic EVM metrics developed to overcome such downfalls and better monitor and control the project time performance are reviewed and analyzed. Each solution is typically developed to address specific limitations; however, they can be generally grouped into two main approaches: top-down control and bottom-up control.

On one hand, top-down project control operates from a holistic perspective, emphasizing the overall project status. Indeed, to assess the project's health, it starts by using high-level performance metrics, such as those offered by Earned Value Management (EVM), to then drill down to pinpoint and fix particular problematic activities when disparities arise. The bottom-up approach, on the other hand, focuses on individual activities from the outset. In this method, activities are prioritized based on their sensitivity or potential impact on the project, ensuring that critical tasks are closely monitored and managed. A clear visual representation of the differences between these two approaches can be found in Figure 4.1.

Figure 4.1 Top-down and Bottom-up Project Control

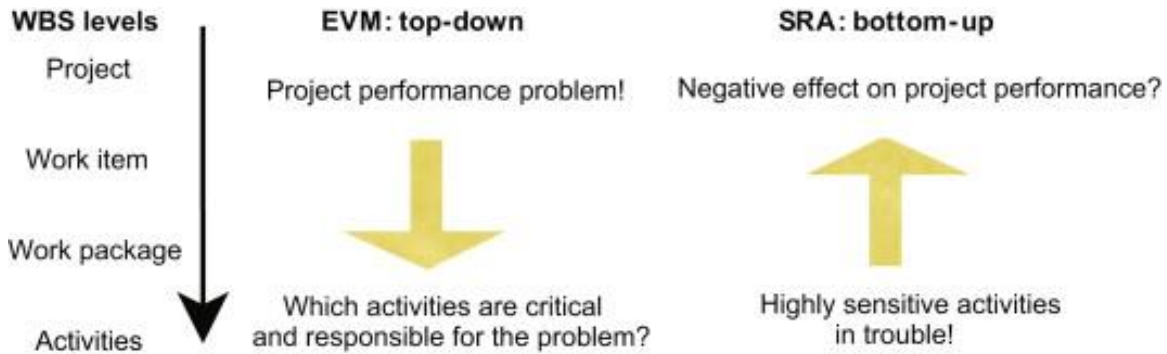

Vanhoucke, M., 2011

In the upcoming sections, these concepts will be explored in greater depth, and a comprehensive examination of the methodologies and techniques introduced to effectively implement top-down and bottom-up control will be conducted. Furthermore, an analysis of their strengths and limitations within the context of improving project time performance will be presented, thus shedding light on valuable strategies for project managers seeking to enhance their schedule monitoring practices.

4.1 Top-down Project Control

Top-down project control involves tracking the overall project's progress and comparing it to predefined thresholds that signal the limits over which the project is expected to be late. Various methods have been developed by researchers and practitioners to implement top-down project control, mainly revolving around three core approaches: Buffer Management (BM), Statistical Analysis (STA), and Earned Value Management (EVM). Buffer Management (BM) consists of assigning reserve resources, i.e., buffers, to critical and non-critical activities to ensure that unforeseen delays or challenges do not derail the project's schedule. These then constitute the aggregated buffer, whose consumption is measured during project progress and compared with the

threshold value, i.e., the planned buffer consumption (Song, J., Martens, A., & Vanhoucke, M., 2022). Statistical Analysis (STA), on the other hand, makes use of a range of statistical techniques, i.e., traditional statistical techniques, Bayesian statistics, Kalman filter, and statistical control chart to detect duration and cost deviations and set threshold values on these deviations (Song, J., Martens, A., & Vanhoucke, M., 2022). While these approaches may be interesting to analyze, the focus of this chapter will be solely on EVM-based metrics. Indeed, EVM represents the most used and common tool in top-down project monitoring, endorsed by the PMI's PMBOK® Guide as the recommended approach. Consequently, most research studies in the field of project control rely on EVM, with Buffer Management (BM) and Statistical Analysis (STA) receiving less attention.

The approaches discussed below are, therefore, all EVM-based, and each of them aims at overcoming one or more of the traditional EVM limitations. Firstly, the initial EVM extensions presented in the literature are introduced, i.e., Planned Value methodology (PV), Earned Duration (ED), Earned Schedule (ES), and Earned Duration Methodology (EDM), all of which offer solutions to overcome the dependency of classic EVM time performance metrics on value-based measurements. Secondly, other approaches based mainly on Monte Carlo simulations, fuzzy logic, and the introduction of new metrics, are discussed. All these studies have the purpose of considering the effects of variability and uncertainty on the project to better assess the magnitude of deviations and enhance total project duration forecasting. Finally, a recently proposed metric is introduced, attempting to combine the strengths of the two aforementioned groups: better forecasting project durations and independence from value-based measures, all with the simplicity of a deterministic-based method.

4.1.1 Anbari, F. T. (2003). Earned value project management method and extensions.

The Earned Value Method was introduced by Anbari in 2003 to overcome some of the shortcomings found in traditional Earned Value Management (EVM) approaches. Although the EV method is based on EVM metrics, it provides a more holistic approach to project management by integrating three critical elements: scope, cost, and time management (Anbari, F. T., 2003); thus ensuring that projects are not only completed within budget and on time but also meet the defined scope. The introduction of the PV method in EVM analysis was likely a response to the need for a more accurate and comprehensive way to measure project performance, especially in terms of time. Indeed, as previously mentioned, researchers acknowledged the need to improve the assessment of a schedule's progress by converting the performance measurement into its equivalent unit of time, thus decoupling them from monetary values.

Focusing on time performance tracking, the PV method introduces two new metrics to EVM: the Planned Value Rate (PVR) and the Time Variance (TV).

- Planned Value Rate (PVR): This metric aims at providing a consistent rate of work completion, indicating how much value should be achieved for each unit of time throughout the project's duration (Borges, W. F., & Mário, P. do., 2017). In particular, the PVR is a linear approximation of the rate at which the total Planned Value (PV), i.e., the BAC, is achieved over a project's Planned Duration (PD), and is computed as follows:

$$PVR = BAC / PD \quad (10)$$

- Time Variance (TV): Similar to Schedule Variance (SV), this metric assesses the deviation between the planned and actual progress of the project in terms of schedule. However, the TV quantifies such performance in units of time, thus offering project managers a tangible

measure to assess and address potential scheduling issues. To achieve this, the TV converts Schedule Variance (SV) into a time-based measure by dividing it by PVR, essentially estimating how much time the current variance SV represents given the planned rate of value achievement. Therefore, the TV formula in Anbari's model is the following:

$$TV_{pv} = SV / PVR \quad (11)$$

where the pv indication denotes the PV method employed.

In general, a positive TV indicates that the project is ahead of schedule, while a negative TV indicates it is behind schedule, in the same way as the SV. Once the TV_{pv} is computed, the $TEAC_{pv}$ can be estimated through the following formula:

$$TEAC_{pv} = PD - TV_{pv} \quad (12)$$

4.1.2 Jacob, D. (2003). Forecasting project schedule completion with earned value metrics.

This approach was introduced in 2003 by Jacob to address, once again, the concerns regarding the monetary nature of schedule performance metrics proposed in traditional EVM. The methodology introduces a new concept: the Earned duration (ED), which is essentially the equivalent of Earned Value (EV) but expressed in time units:

- Earned Duration (ED): This new metric represents the amount of time, based on the project's original schedule, that corresponds to the actual work completed up to a specific point, thus quantifying how much of the project's planned timeline has been effectively realized. Specifically, the ED is defined as “the effective time duration for which value has been earned on a project, given its current schedule performance” (Borges, W. F., & Mário, P. do., 2017). In Jacob's methodology, the ED is computed by multiplying the Schedule

Performance Index (SPI) with the Actual Time (AT), i.e., the interval from the project's inception to the point of evaluation:

$$ED = SPI \times AT \quad (13)$$

Once the ED is assessed, managers can easily compute the Time Variance (TV_{ed}) as follows:

$$TV_{ed} = ED - AT \quad (14)$$

where the pv indication denotes the ED method employed.

This formula clearly shows the parallelism with the metrics used in classic EVM, where the SV at a specific point during project execution is computed as the difference between the corresponding EV and the AC. Furthermore, knowledge of AT, ED, and PD is sufficient to calculate the forecast earned duration in units of time, here indicated as $TEAC_{ed}$:

$$TEAC_{ed} = \max (PD ; AT) - TV_{ed} \quad (15)$$

Notably, the formula proposed by Jacob introduces a further precaution. Indeed, considering the maximum value between AT and PD allows AT to replace PD when the actual project duration exceeds the planned project duration, making the formula applicable even in such situations.

4.1.3 Lipke, W. (2003, January). Schedule is different.

Although the previous methods address the concerns discussed, they heavily rely on the classic SV and SPI metrics. Nevertheless, as Lipke (2003) argued, such metrics give false and undependable time forecasts near the end of the project. Indeed, after a project is two-thirds complete, EVM schedule performance metrics become unreliable, as EV invariably converges on PV and SPI on one, independently of the actual project progress (Tzaveas, T., Katsavounis, S., Kalfakakou, G., 2010). Recognizing this inherent flaw in traditional EVM, Lypke (2003) proposed

the ES technique as a time-based approach to measure schedule performance. The ES idea is simple: identify the time at which the amount of EV accrued should have been earned (Tzaveas, T., Katsavounis, S., Kalfakakou, G., 2010). The methodology relies on two leading indicators, the ES and the Actual Time (AT).

- Earned Schedule (ES): By projecting the cumulative EV curve onto the PV curve, it is possible to determine on the x-axis when that amount of EV should have been achieved according to the schedule. The duration from the beginning of the project to this intersection on the time axis is the Earned Schedule. This concept can be better understood through the graphical representation reported in Figure 4.2 below.
- Actual Time (AT): Simply, the AT is the duration at which the EV accrued is recorded (Tzaveas, T., Katsavounis, S., Kalfakakou, G., 2010).

The EVM schedule performance metrics, SV and SPI, can now be computed based on these indicators. Schedule Variance becomes

$$SV(t) = ES - AT \quad (16)$$

while the SPI becomes

$$SPI(t) = ES / AT \quad (17)$$

where the indication (t) represents the time-based approach employed in calculating them. Starting from these indicators, it is also possible to forecast time at completion, here indicated as TEAC(t):

$$TEAC(t) = PD / SPI(t) \quad (18)$$

A graph representing the major ES components can be found, once again, in Figure 4.2.

Figure 4.2 Earned Schedule Components

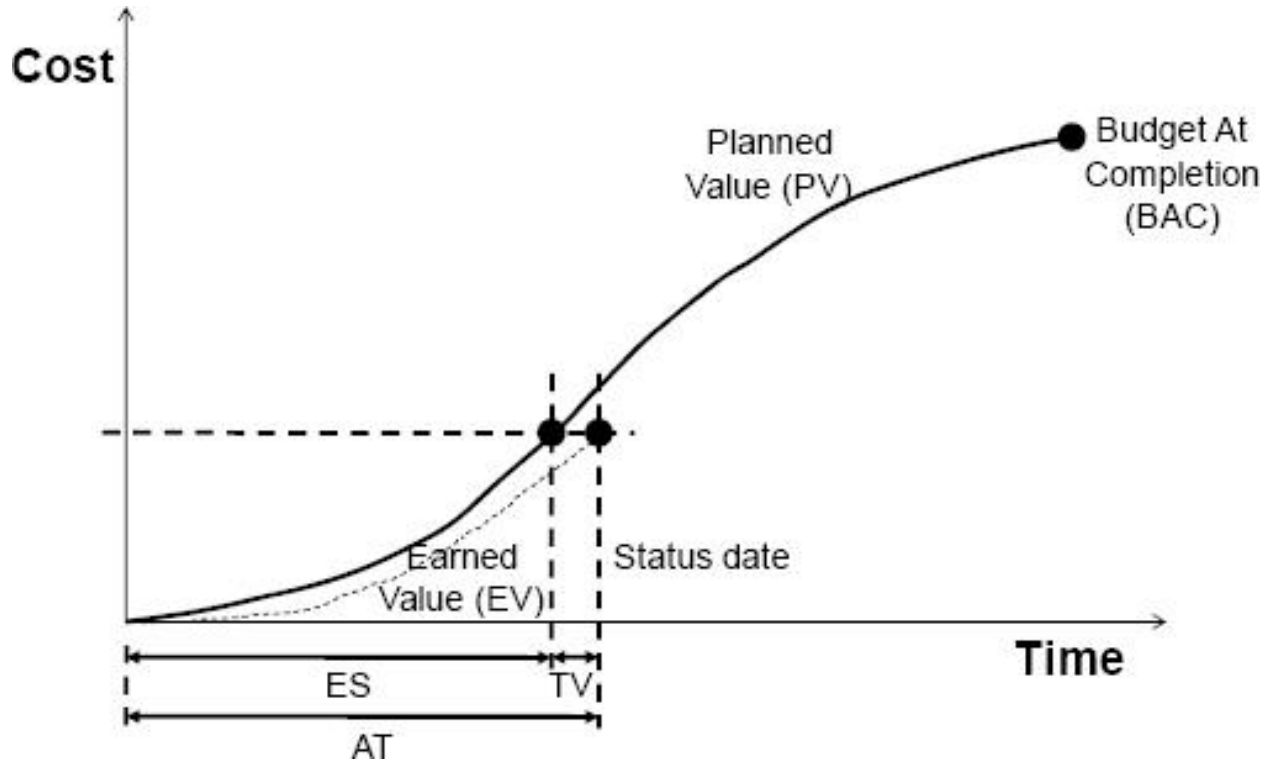

Anbari, F. T., 2011

4.1.4 Khamooshi, H., & Golafshani, H. (2014). *EDM: Earned duration management, a new approach to schedule performance management and measurement*.

Studies by Vandevoorde and Vanhoucke (2007) and Vanhoucke and Vandevoorde (2009) showed that the performance measures of Schedule Variance $SV(t)$ and Schedule Performance Index $SPI(t)$ based on ES are the best indicators for project schedule assessment among the three methods analyzed above. Nonetheless, the ES approach presents some conceptual shortcomings. The main drawback of $SPI(t)$ is the fact that, similar to SPI, it measures schedule performance using monetary terms of Earned Value (EV) and Planned Value (PV) (Khamooshi, H., & Golafshani, H., 2014). Consequently, ES-based schedule performance indicators may still exhibit a significant dependence on these monetary values, potentially resulting in inaccuracies. Indeed,

while correlations between a project's duration and cost patterns may exist, deviations between these structures can result in diminished precision in the provided schedule evaluation, particularly as the gap between time and cost widens. To give an example, a completed procurement activity with a high PV and short duration could dramatically change SPI(t) by overshadowing large delays of inexpensive activities on the critical path (Khamooshi, H., & Golafshani, H., 2014). For this reason, the Earned Duration Methodology (EDM) was created by Khamooshi & Golafshani in 2014. Its foundation lies in the exclusive usage of time-based data for the generation of physical progress indicators. Thus, schedule performance indicators become free from any dependency on planned cost values, and therefore, are no longer influenced by them.

The Earned Duration Methodology (EDM) starts by defining new time metrics at the micro or activity level, to then compute them at the project level. Specifically, the metrics are the following (Khamooshi, H., & Golafshani, H., 2014):

- Total Planned Duration (TPD): TPD is the sum of PD_i for all the planned activities at a particular point in time according to the baseline plan, where the Planned Duration of scheduled activity i (PD_i) represents the authorized duration assigned to the scheduled work to be accomplished for activity i at that time (Khamooshi, H., & Golafshani, H., 2014). This variable for the EDM method is the duration counterpart or equivalent to PV of an activity in EVM. Therefore, the TPD is computed as:

$$TPD = \sum_{i=1}^n PD_i \quad (19)$$

where n is the number of in-progress and completed activities up to that time.

- Baseline Planned Duration (BPD): This metric is the authorized duration assigned to the scheduled work to be accomplished for the entire project irrespective of the status date

(Khamooshi, H., & Golafshani, H., 2014). The difference between BPD and TPD is similar to the one between BAC and PV: the former is the total planned duration and never changes during the project; the latter is dynamic and has different values depending on the specific date on which it is measured.

- Total Earned Duration (TED): This metric is computed as the sum of ED_i for all the in-progress and completed activities at a particular point in time, and represents the EDM counterpart of the EV. As before, the measurement starts at the activity level. Specifically, the Earned Duration of scheduled activity i (ED_i), at any point in time, is the value of work performed expressed as a proportion of the approved duration assigned to that work for activity i (Khamooshi, H., & Golafshani, H., 2014). In order to compute the ED_i , however, two more micro-level metrics need to be defined, the Baseline Planned Duration of scheduled activity i (BPD_i) and the Activity Progress Index, for activity i (API_i). The former is simply the equivalent of the BPD but relative to a single task i . The latter, on the other hand, measures the progress of the activity at any point in time, typically through the assumption that progress made on the activity has a linear relationship with time (Khamooshi, H., & Golafshani, H., 2014). It is obvious that for an activity that is yet to begin the API_i equals zero, whereas it equals 1 for a completed activity and any value in between for one in progress. Overall, the ED_i is computed as:

$$ED_i = BPD_i \times API_i \quad (20)$$

whereas the TED as:

$$TED = \sum_{i=1}^n ED_i \quad (21)$$

- Earned Duration (ED(t)): The ED(t) represents the duration corresponding to the Total Earned Duration (TED) on the Total Planned Duration (TPD) S-curve (Khamooshi, H., & Golafshani, H., 2014). This metric is the equivalent of the ES introduced by Lypke but for EDM. Indeed, it is obtained by projecting the cumulative TED curve onto the TPD curve to then determine on the x-axis when that amount of TED should have been achieved according to the schedule.
- Total Actual Duration (TAD): This metric is obtained, once again, by summing the AD_i for all the in-progress and completed activities at a specific point in time, where the Actual Duration of scheduled activity i (AD_i) is the time in calendar units between the actual start of the activity and either that point in time if the activity is in progress or the actual finish date if the activity is complete (Khamooshi, H., & Golafshani, H., 2014). The TAD represents, in this EDM model, the counterpart of AC in EVM.

$$TAD = \sum_{i=1}^n AD_i \quad (22)$$

For the sake of clarity, it is important to state again that TPD, TED, and TAD for EDM are equivalent twins of PV, EV, and AC for EVM. This parallelism can be clearly appreciated in Figure 4.3, shown below.

The EDM continues by defining progress and performance measures for duration and cost. While also in this case micro-level measures are proposed in the model, they are not required to compute the macro-level ones required for top-down control. For this reason, the former will not be discussed in this section. The metrics introduced by Khamooshi and Golafshani (2014) to monitor progress and performance are:

- Project Progress Index (PPI): The PPI is a measure of the overall duration progress of the project, reporting the proportion of the project's baseline duration that has been effectively realized or accomplished up to a given point in time. In simpler terms, it can be seen as the percentage of the project's planned schedule that has been completed up to the current moment. The PPI is computed as:

$$PPI = ED(t) / BPD \quad (23)$$

It is to be noted that the PPI value is always less than or equal to one: it starts from zero at the project inception and approaches 1 as the project nears completion, i.e., as the ED(t) converges on BPD.

- Duration Performance Index (DPI): The DPI measures how well the project is doing in achieving the target completion date in consideration of the critical path (Khamooshi, H., & Golafshani, H., 2014). Specifically, it is defined as:

$$DPI = ED (t) / AD \quad (24)$$

Deductively, a DPI's value less than one indicates that the project is falling behind schedule, while a value greater than one that the project is ahead of schedule. It is to be noted that in this model Actal Time (AT) is referred to as Actual Duration (AD). This metric is often seen as the SPI(t) counterpart of the EDM model.

- Earned Duration Index (EDI): The EDI is a duration-based measure of overall work performed in terms of Earned Duration, in comparison with the work planned up to that point in time (Khamooshi, H., & Golafshani, H., 2014). It is measured as:

$$EDI = TED / TPD \quad (25)$$

Unlike the DPI, which evaluates the project's alignment with its target completion date, the EDI focuses solely on the comparison between work achieved and work forecasted, without accounting for activity dependencies or their interplay in reaching the project's end date. For this reason, this metric is often seen as the SPI counterpart of the EDM model. Evidently, the interpretation of this measure aligns with previous metrics, where values greater than one indicate progress ahead of plan and values less than one suggest a delay.

To provide the reader with a clearer and deeper understanding of the model, a graph showing all the EDM macro-level components is presented in Figure 8:

Figure 4.3 EDM Components

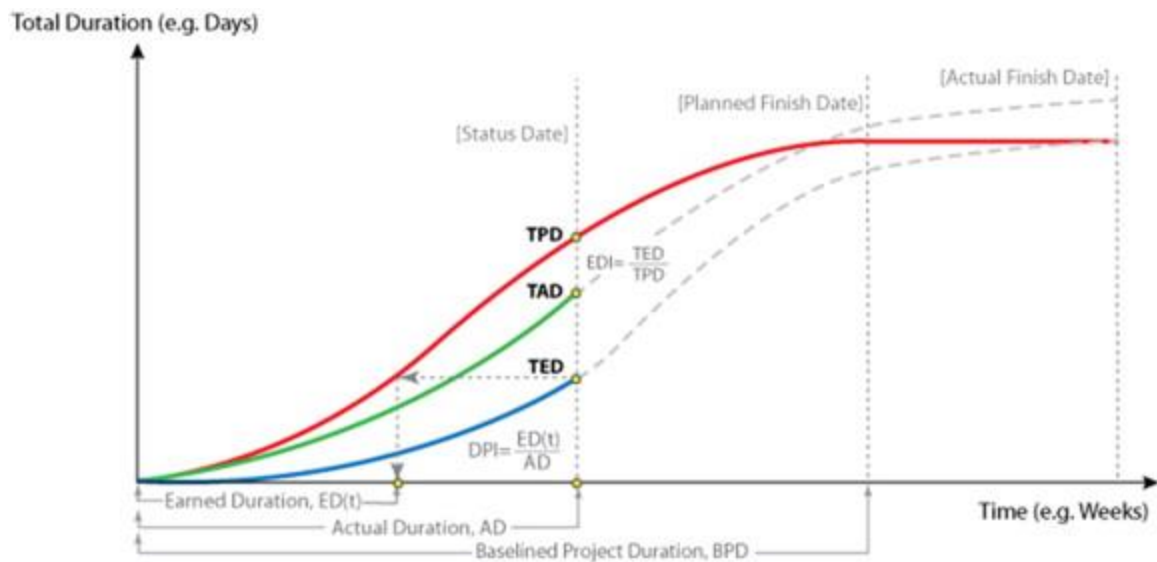

Khamooshi, H., & Golafshani, H., 2014

Kamooshi and Golafshani criticized the use of performance metrics to predict the future state of the project, as it implies that current performance continues and remains the same for the remainder of the project. Nonetheless, they proposed forecasting equations for EDM similar to the classical forecasting approaches of EVM, but with the clear stipulation that one must explicitly

assume consistent performance throughout the project's duration. In particular, Kamooshi and Golafshani (2014) suggested two methodologies to determine the Time Estimate at Completion through EDM metrics:

$$TEAC_{edm} = BPD / DPI \quad (26)$$

or, alternatively:

$$TEAC_{edm} = AD / PPI \quad (27)$$

4.1.5 Hillson, D. (2014). How risky is your project — And what are you doing about it?

As previously pointed out, forecasting the future performance of a project through EVM metrics provides quite approximate results, as it relies on the fragile assumption that past or current performance will remain unvaried for the rest of the endeavor. It is important to note that this statement is true for any performance metrics developed that exclusively look at the present, whether it is based on traditional EVM, ES, or EDM to give an example. Building on this, various methodologies have been proposed to better predict future behaviors of projects, many of which are based on the integration of EVM with Risk Management (RM). Indeed, while EVM primarily deals with past data, RM serves as a forward-looking radar, diligently scanning the uncertain future to identify potential risks and opportunities (Hillson, D., 2014). However, RM's exclusive focus on the future is also one of its key weaknesses. Therefore, if EVM is weakened by assuming that future performance can be predicted from past performance, and if RM is weakened by looking only forward with no real awareness of the past, a useful synergy might be obtained if a combined EVM-RM approach were able to address these weaknesses (Hillson, D., 2014).

The first and simplest methodology proposed to allow such an integration consists of the employment of Monte Carlo simulation. The Monte Carlo simulation is a computational technique

that uses random sampling to model and analyze complex systems or processes, generating a range of possible outcomes to assess probabilities and uncertainties. The simulation output in the project management environment is typically an S-curve representing the cumulative probability density of different project outcomes (Hillson, D., 2014). By analyzing this curve, project managers can answer critical questions about overall project risk, i.e., the impact of uncertainty on the entire project, such as the likelihood of project success or failure and the potential range of variation in outcomes. An example of a Monte Carlo simulation S-curve for total project duration is shown in Figure 4.4. The Monte Carlo simulation S-curve presented in Figure 4.4 provides valuable insights beyond the project schedule, offering a comprehensive view of overall project risk. For instance, let's assume that the initial project duration was 34 weeks. The analysis indicates that the likelihood of the project meeting its initial estimate is less than 20%, whereas the expected outcome is slightly more than 35 weeks. Furthermore, the Monte Carlo S-curve reveals a potential variation (assuming a range of uncertainty from the 5th to the 95th percentile) in total project length of 4 weeks against a target duration of 34 weeks, representing 12% of the expected project time

Figure 4.4 Monte Carlo S-curve for Project Duration

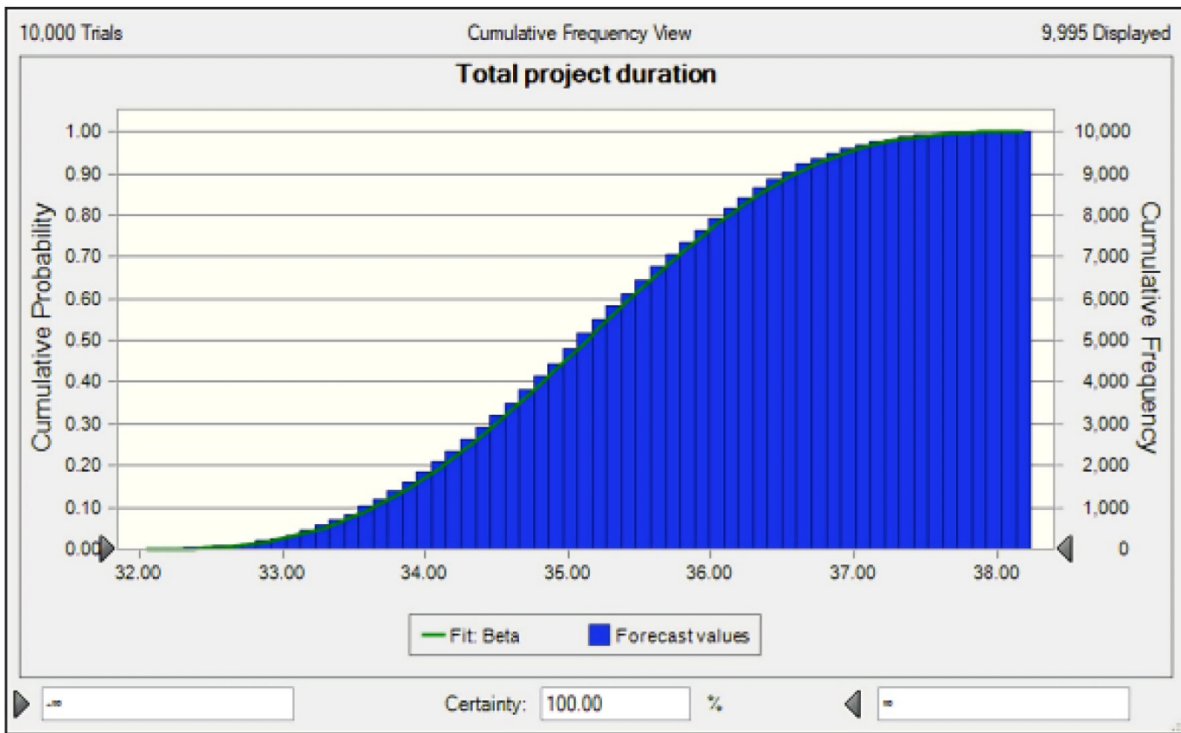

Overall, the Monte Carlo simulation is a remarkably powerful tool that can swiftly and efficiently overcome the limitations previously discussed. Furthermore, it enables project managers to move beyond deterministic assumptions, considering uncertainties and variations in task performance.

4.1.6 Bagherpour, M., Zareei, A., Noori, S., & Heydari, M. (2009). Designing a control mechanism using earned value analysis: An application to production environment.

Another viable methodology proposed to account for uncertainty associated with activity duration in earned value analysis was put forth by Bagherpour et al. (2009). Although they do not explicitly mention integrating EVM and RM, their creation of a model that accounts for uncertainty implies such integration. Indeed, their reasoning behind the proposed model is rooted in the acknowledgment that “duration of activities in a project network has often been associated with

ambiguity and imprecise estimations, which shows the involvement of some uncontrollable and unknown parameters such as weather conditions, degree of labor experience, and reworking. It is thus important to apply a method dealing with this issue.” (Bagherpour, M., Zareei, A., Noori, S., & Heydari, M., 2009). Specifically, their approach relies on the employment of fuzzy logic. Even though the subsequent section will primarily concentrate on schedule performance metrics, the model proposed by Baghepur et al. is developed for both schedule and cost control. Therefore, the same considerations discussed for duration also apply to activity costs.

In this model, activity duration is represented by a Triangular Fuzzy Number (TFN), i.e. (a, b, c) , in which a , b , and c represent optimistic, moderate, and pessimistic duration respectively. To explain further, it is expected that the activity duration be equal to b and it is almost impossible for the activity duration to fall outside a and c (Bagherpour, M., Zareei, A., Noori, S., & Heydari, M., 2009). To establish the TFN, the typical approach employed is the three-point estimate, but different approaches can be used, which however will not be discussed here. Once the TFN is defined, the α cut method is applied to extract a range within the TFN in which there is the α confidence level that the overall duration of the activity will fall. For this reason, a new a^α and c^α will be computed as follows:

$$a^\alpha = a + \alpha (b - a) \quad (28)$$

$$c^\alpha = c - \alpha (c - b) \quad (29)$$

defining a new TFN^α as (a^α, b, c^α) . An example of this concept can be found in Figure 4.5:

Figure 4.5 Triangular Fuzzy Number

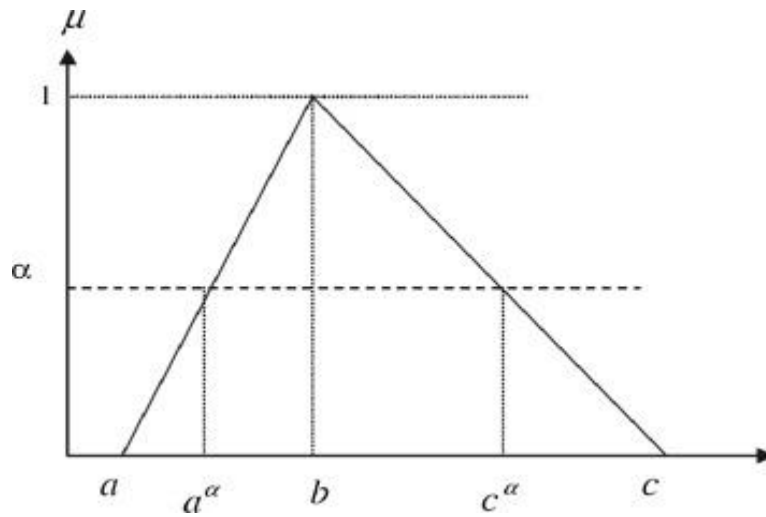

Bagherpour, M., Zareei, A., Noori, S., & Heydari, M., 2009

To give an example of how this first step works, let's assume a TFN (5, 7, 10) in days for a specific activity. If managers decide that they want a range of durations where the likelihood of the real duration falling within it is at least 50%, the resulting a^α will become $5 + 0.5 (7 - 5) = 6$ days, while c^α will become $10 - 0.5 (10 - 7) = 8.5$ days. This means that there's at least a 50% likelihood that the task will take between 6 and 8.5 days. It is quite obvious, therefore, that by changing the value of the alpha cut, the user can control the variation in the estimation of the duration. Specifically, higher alpha cut values result in a smaller range for the processing duration. Since the model considers both activity duration and its related cost as TFN and applies them in EVA, three different PVs are generated (PV_{a^α} , PV_b , PV_{c^α}). As a consequence, three different BACs and PDs are calculated as well, representing optimistic, moderate, and pessimistic budgets at completion and planned durations. Therefore, the EV, which is equal to the multiplication of BAC with the percentage of the work completed, is also extended as follows considering the above concept:

$$EV_a^\alpha = BAC_a^\alpha \times \%complete \quad (30)$$

$$EV_b = BAC_b \times \%complete \quad (31)$$

$$EV_c^\alpha = BAC_c^\alpha \times \%complete \quad (32)$$

Nonetheless, only EV_b is used in the PV control mechanism in order to identify schedule performance conditions. Specifically, a comparison between PV and EV_b is employed to assess a project's schedule performance, determining whether it is on schedule, ahead of schedule, or behind schedule. Figure 4.6 illustrates various planned value curves, each representing different project schedule performance scenarios. The project schedule condition is stated as “poor” if the EV_b curve falls between the PV_b and PV_c^α curves and it is stated as “good” if the EV_b curve falls between the PV_a^α and PV_b curves. Finally, beneath the PV_c^α curve is the worst schedule condition of a project which is defined as “worst”, while above the PV_a^α is the best condition of the project which is defined as “Superstar” (Bagherpour, M., Zareei, A., Noori, S., & Heydari, M., 2009).

Figure 4.6 Different Conditions of Schedule Performance

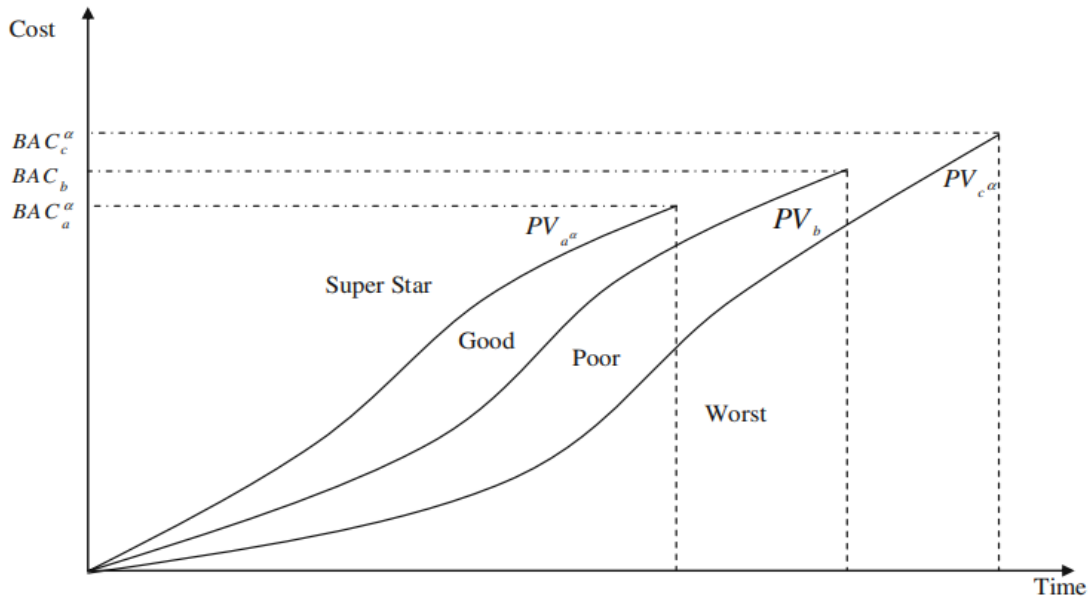

Bagherpour, M., Zareei, A., Noori, S., & Heydari, M., 2009

Using the same logic but translated into values, it is possible to compute for each of the three PVs the Schedule Variance (SV) and Schedule Performance Index (SPI):

$$SV_a^\alpha = EV_b - PV_a^\alpha \text{ and } SPI_a^\alpha = EV_b / PV_a^\alpha \quad (33)$$

$$SV_b = EV_b - PV_b \text{ and } SPI_b = EV_b / PV_b \quad (34)$$

$$SV_c^\alpha = EV_b - PV_c^\alpha \text{ and } SPI_c^\alpha = EV_b / PV_c^\alpha \quad (35)$$

By looking at the previous graph, it is immediately apparent that the SV and SPI Triangle Fuzzy Numbers must be interpreted as shown below:

Schedule variance	$SV_a^\alpha < 0$	$SV_c^\alpha > 0$ and $SV_b < 0$	$SV_b > 0$ and $SV_a^\alpha < 0$	$SV_a^\alpha > 0$
Spi	$SPI_c^\alpha < 1$	$SPI_c^\alpha > 1$ and SPI_b	$SPI_b > 1$ and $SPI_a^\alpha < 1$	$SPI_a^\alpha > 1$

		<1	1	
Schedule performance condition	Worst	Poor	Good	Superstar

4.1.7 Pajares, J., & López-Paredes, A. (2011). An extension of the EVM analysis for Project Monitoring: The cost control index and the schedule control index.

Another viable methodology to achieve EVM and RM integration was proposed by Pajares and López-Paredes in 2011. Their approach is centered on the implementation of two new metrics into EVM: the Schedule Control Index (SCoI) and the Cost Control Index (CCoI). This methodology relies on two leading indicators, the Risk Baseline and Buffer. The purpose of these indicators is to link the information obtained using quantitative risk analysis, i.e., the probability function and distribution of project duration and cost, as well as the corresponding levels of maximum overruns within a specific confidence level, with the EVM data, i.e., the variances and performance indexes that inform whether the project is overbudget or behind schedule. It is to be noted that, given the focus on schedule performance, this section will only cover the relative metrics. However, since the calculations used for cost control have the same logic and structure as the ones used for the schedule, the former can be easily deduced from the latter.

To better understand how these metrics work they will be described and implemented in a simple project example. Specifically, the project consisted of four activities with an initially planned duration of 9 weeks and a budget of 4800 monetary units (m.u.). However, it was ultimately completed in 11 weeks, costing 5090 m.u. At the project's inception, it is crucial to compute the project's Risk Baseline and Buffers. The project Risk Baseline (RB) is the evolution of the value of the project's remaining risk over time: the remaining variability of project duration during the project life cycle (Pajares, J., & López-Paredes, A., 2011). Assuming that project

performance has been as projected up until time t , project risk at time t is calculated as the risk of a project comprised of the remaining uncompleted tasks. Typically, the RB is divided into two categories: Cost Risk Baseline (CRB) and Schedule Risk Baseline (SRB). Whereupon the Schedule Project Buffer (SPB_f) can be defined. In particular, the SPB_f is determined by calculating the difference between the maximum accepted duration, established at a specific confidence level (scl%), and the duration mean value, where the scl% is chosen by managers depending on the project characteristics. To ascertain the time values corresponding to a particular confidence level, a Monte Carlo simulation is often performed on the project. The results for the project at hand are shown in Figure 4.7:

Figure 4.7 Monte Carlo simulation results

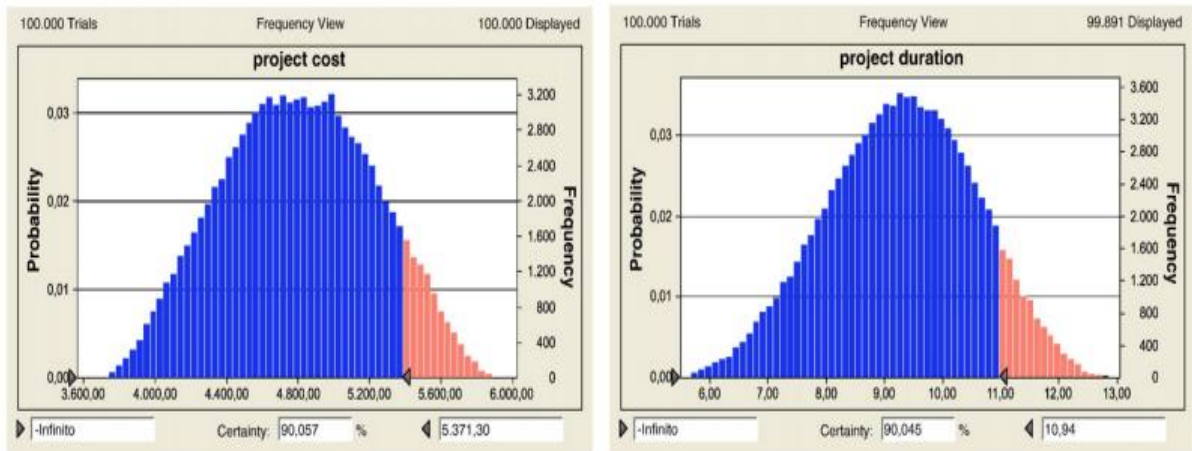

Pajares, J., & López-Paredes, A., 2011

For the current example, the resulting mean value was 9.29 weeks, while the 90% confidence interval percentile was 10.94 weeks. As a result, SPB_f at 90% was equal to 1.65 weeks. Once the buffer is computed, the maximum Schedule Buffer (SB_ft) for each interval (t-1, t) can be

determined by distributing the SPBf proportionally over all time intervals. The methodology proposed divides the buffers by using weights, indicated as w_s , equal to the projected schedule risk decrease in each interval, that is, the difference between two adjacent points along the risk baseline:

$$w_{S_t} = SRB_{t-1} - SRB_t, \quad (36)$$

where SRB_t is the schedule risk baseline at time t . It is important to note that $\sum_{t=1}^T w_s(t) = SRB_0 - SRB_T = \sigma_{ps}^2$, where σ_{ps}^2 is the total project cost variance. In fact, the risk baselines at $t = T$ are 0, whereas at $t = 0$ equals the total project variability. Therefore, the maximum schedule buffers (SBf_t) during the interval $(t-1, t)$ can be computed as a percentage of the total buffer, where the rate is given by the ratio of the corresponding weight in the period t to the sum of all the weights:

$$SBf_t = (w_{S_t} / \sigma_{ps}^2) * SPB_f \quad (37)$$

At this stage, it is possible to determine in each period t which is the cumulative Accepted Schedule Buffer ($ASBf_t$), i.e., the maximum accepted cumulative deviation from planned values:

$$ASBf_t = SBf_t + ASBf_{t-1} \quad (38)$$

Hence, this value indicates at a determined time t the maximum permissible -SV (Schedule Variance) that can be accepted to complete the project without exceeding the pre-established tolerance levels for the schedule. Indeed, as the project progresses, $ASBf_t$ must be compared to the corresponding EVM metrics available in each period t through the Schedule Control Index ($SCoI_t$):

$$SCoI_t = ASBf_t + SV(t) = ASBf_t + ES - AT \quad (39)$$

Where $SV(t)$ is the Earned Schedule Variance obtained with the Lypke methodology. If the $SCoI_t$ is negative, it signifies that the total schedule deviation (-SV) exceeds the cumulative buffer,

indicating that the project changes have surpassed the regular and planned variability. In such cases, corrective actions should be taken.

Overall, the purpose of SCoI is to alert project managers early on about systemic and structural changes affecting the project risk and schedule for a determined confidence level scl%. (Pajares, J., & López-Paredes, A., 2011). The value of SCoI throughout the analyzed project is illustrated in Figure 4.8. As depicted, the SCoI is negative by the end of the project. In essence, the total duration of 11 weeks exceeds the tolerance level of the 90% percentile, equal to 10.94 weeks.

Figure 4.8 Project Schedule Control Index evolution

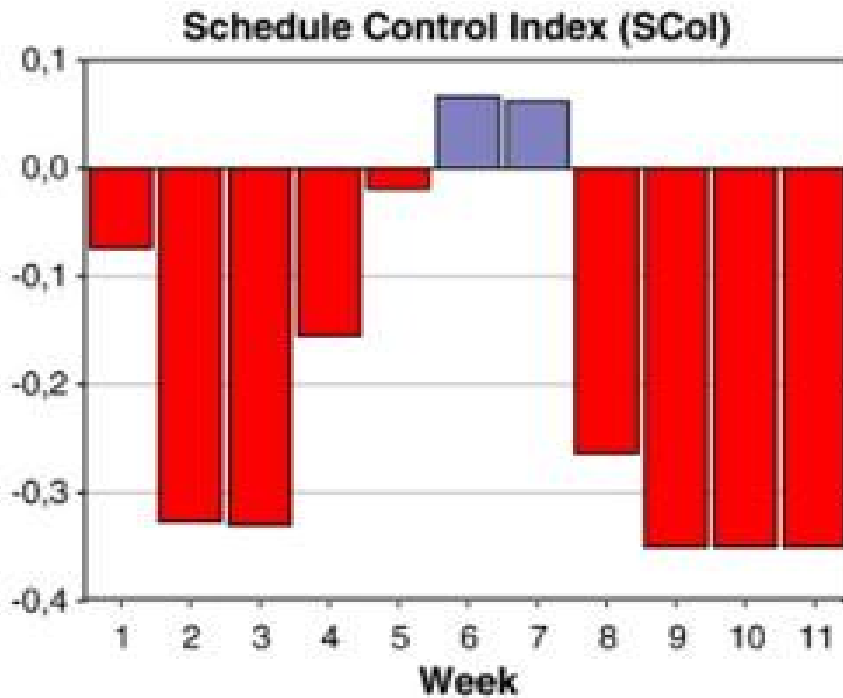

Pajares, J., & López-Paredes, A., 2011

4.1.8 Acebes, F., Pajares, J., Galán, J. M., & López-Paredes, A. (2014). A new approach for project control under uncertainty. going back to the basics.

Building on the concepts of CCoI and ScoI, Acebes et al. (2014) introduced an innovative methodology with the objective of enabling project managers to assess whether a project remains within the expected range of variation at any given point in its execution. What distinguishes their novel approach is its exclusive reliance on Monte Carlo simulations. Indeed, while Monte Carlo simulations have been traditionally used to estimate the statistical distributions of project cost and duration at completion, Acebes et al. (2014) recognized that this technique could also be applied to predict such distributions at any intermediate point during a project's lifecycle, such as when it is 50% complete. Their novel approach introduces a triad, consisting of (x, T_{xj}, C_{xj}) , where x is the percentage of completion (measured in terms of cost), $C_{xj} = x * C_j$ is the money spent when the project has been completed at $x\%$ (within simulation j); T_{xj} is the time when the cost C_{xj} was achieved and C_j is the total project cost in the j -th simulation (Acebes, F., Pajares, J., Galán, J. M., & López-Paredes, A., 2014). By performing several Monte Carlo simulations each for a specific percentage completion of the project, it is, therefore, possible to compute the statistical distributions for cost and duration at $x\%$ of project completion (see Figure 4.9, left side distributions), and the corresponding percentiles (indicated as P_dD , where the subscript indicates either duration (d) or cost (c) and D the confidence level). The particular case of $x = 1$ represents the situation at the end of the project (Figure 14, right side distributions).

Figure 4.9 Monte Carlo Simulation applied at the end of the project and at $x\%$ completion

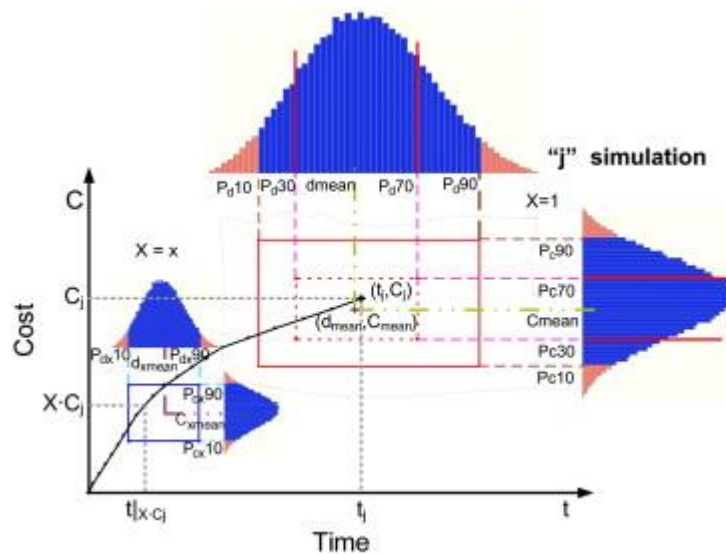

Acebes, F., Pajares, J., Galán, J. M., & López-Paredes, A., 2014

In order to explain how the methodology works, the representation of the triad (x, T_{xj}, C_{xj}) is split into the following graphs (Figure 4.10):

Figure 4.10 Triad Framework during project execution

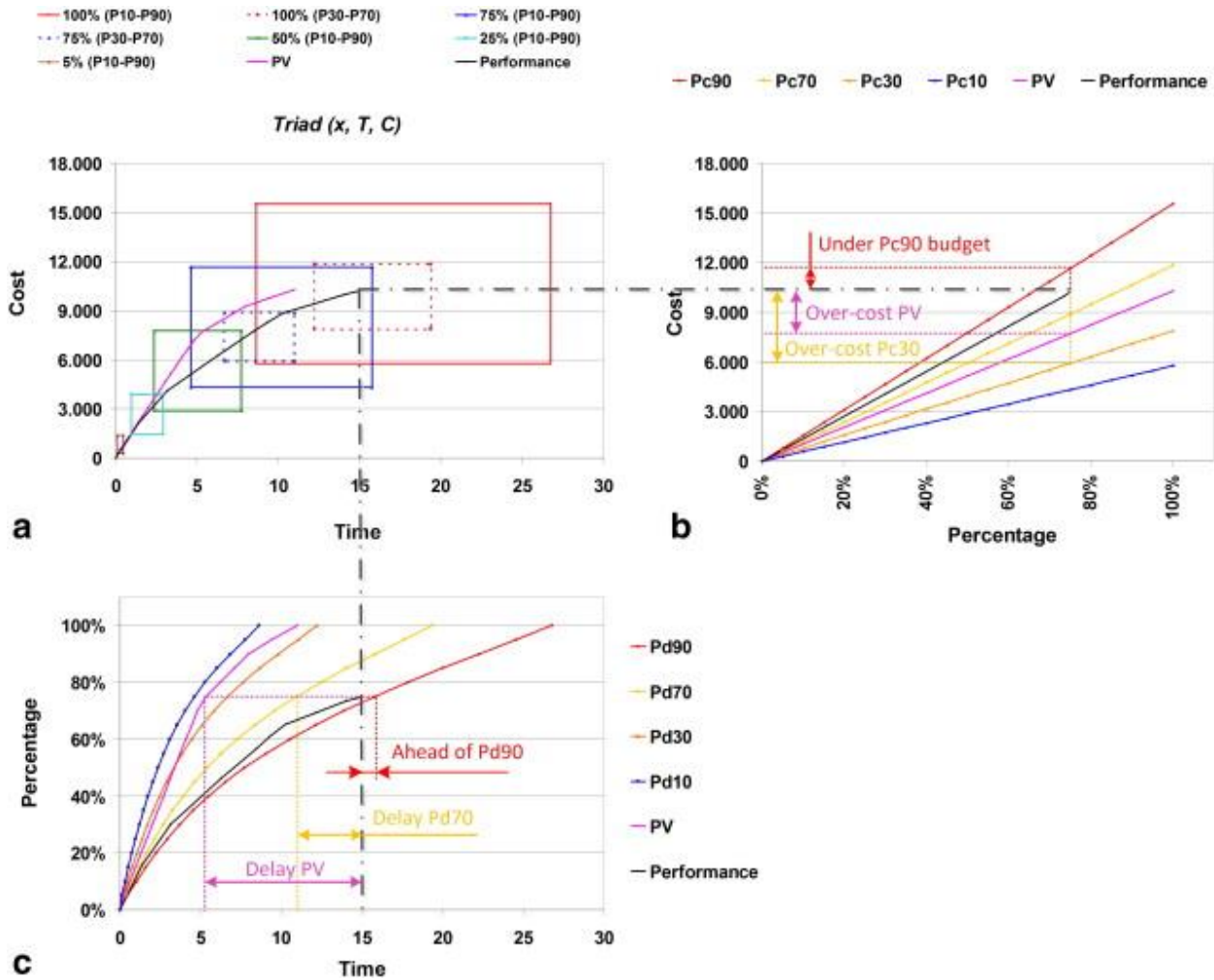

Acebes, F., Pajares, J., Galán, J. M., & López-Paredes, A., 2014)

Figure 4.10.a is akin to the previous Figure 4.9 but places emphasis on different rectangles, each signifying distinct percentiles for various x values. Figure 4.10.c represents the time projection. Specifically, the curves for each percentile P_dD in Figure 4.10.c are obtained by computing for all $x \in [0,1]$ (y-axis) the corresponding time value at that percentile (x-axis). The same happens with costs in Figure 4.10.b. To build the PV curves, on the other hand, a different process is employed. Since at any time t the value of PV_t is predetermined, it is possible to compute the corresponding x_t as:

$$x_t = PV_t / BAC \quad (40)$$

As a result, it will suffice to plot for all values of $x_t \in [0,1]$ the corresponding points (x_t, PV_t) for cost and (t, x_t) for time to get the PV curves. It is to be noted that all these curves are already established during the planning phase. Conversely, the performance curves are developed incrementally during project execution, starting with the AC and EV measurements. Their computation is based on a fundamental assumption of Earned Value Management (EVM): the ratio of EV at a time t to BAC signifies the percentage completion of the project at that specific point in time. Therefore, for $t = \text{Actual Time (AT)}$, it is legit to say that:

$$X_{AT} = EV_t / BAC \quad (41)$$

Consequently, the point (x_{AT}, AC_{AT}) can be drawn in Figure 4.10.b and (AT, x_{AT}) in Figure 4.10.c.

Now that all the metrics are graphically represented, managers can easily assess the status of the project. As with SCoI and CCoI, the primary goal here is to figure out if the performance of the project is compatible with the random nature of the project or if on the contrary, divergences may be explained by means of the occurrence of unexpected events or the instability of the assumptions of the project planning stage (Acebes, F., Pajares, J., Galán, J. M., & López-Paredes, A., 2014). Obviously, there is no predetermined confidence level that can universally report abnormal project progress conditions. Indeed, the appropriate limits to send warning signals and to apply corrective measures depend on the specific context of the project and must therefore be decided by project managers (Acebes, F., Pajares, J., Galán, J. M., & López-Paredes, A., 2014). To give an example, the scenario depicted in Figure 4.10 suggests that the project is delayed compared to the PV. However, whether this delay falls within the normal range of project variability hinges on the chosen confidence level, as it may be acceptable at 90% confidence but concerning at 70%.

4.1.9 Acebes, F., Pajares, J., Galán, J. M., & López-Paredes, A. (2015). A Project Monitoring and control system using EVM and Monte Carlo Simulation.

In a following study conducted jointly by Acebes, Pajares, Lopez-Paredes, and Galan (2015), EVM, Control Indexes, and Triads were compared to gain a better understanding of which could be more beneficial for project managers. The study concluded that the Triad methodology is the most complete and powerful among the three, as it seamlessly integrates uncertainty in the control stage through a system that requires low effort to be implemented and interpreted. Nevertheless, the researchers also acknowledged that this methodology presented a limitation, as it required assuming that EV was linear with work execution, i.e., $EV = \% \cdot BAC$. For this reason, Acebes, Pereda, Poza, Pajares, and Galán (2015) proposed a new triad comprised of the terms (EV, t, c) instead of (% , t, c). Indeed, by measuring the values of EV (earned value) along with the corresponding cost (c) at several intermediate points (t) along the project life cycle at every project simulation, such a hypothesis is no longer required. In addition, the new approximation seems more practical and understandable from the perspective of a practitioner, since it is not straightforward to accurately calculate the % of completion whereas EV is typically a more well-known term.

4.1.10 Acebes, F., Pereda, M., Poza, D., Pajares, J., & Galán, J. M. (2015). Stochastic earned value analysis using Monte Carlo Simulation and Statistical Learning Techniques.

In the same way as before, the approach consists of generating a data universe (realizations of the project) by means of Monte Carlo simulation that is used to find the statistical properties of the project at any point during its execution (Acebes, F., Pereda, M., Poza, D., Pajares, J., & Galán, J. M., 2015). The main difference with the original approach lies in the steps following the Monte Carlo simulation, encompassing the application of advanced statistical methodologies to the data

generated: classification and regression. Specifically, classification involves categorizing items into specific groups based on their characteristics, with the goal of determining which category each item belongs to. Regression, on the other hand, focuses on making predictions about a numeric or continuous variable, often referred to as the outcome, by analyzing a set of variables, which may include attributes of both qualitative and quantitative nature. To put it simply, treating the data as a classification problem allows one to know whether the project will finish in time and cost, whereas processing it as a regression problem allows for forecasting the expected cost and time at the termination of the project (Acebes, F., Pereda, M., Poza, D., Pajares, J., & Galán, J. M., 2015). A detailed exploration of this approach will not be addressed in this paper, as it would require an in-depth explanation and analysis of complex statistical algorithms that would go beyond the scope and context of this discussion. Nonetheless, it is crucial to underscore the methodology's benefits, including its ability to detect anomalies, account for time-cost correlations, predict overrun probabilities, and provide forecasts for project time and duration- all of which are integrated into an easy-to-understand framework that aligns with established Earned Value Management (EVM) practices.

4.1.11 Ballesteros-Pérez, P., Sanz-Ablanedo, E., Mora-Melià, D., González-Cruz, M. C., Fuentes-Bargues, J. L., & Pellicer, E. (2019). Earned schedule Min-Max: Two new EVM metrics for monitoring and controlling projects.

As previously discussed, the EVM-based deterministic approaches are typically unreliable in forecasting project duration, due to their inability to consider the effect of uncertainty and variability on a project's future progress. For this reason, other more advanced techniques have been proposed over the years, such as fuzzy logic, Monte Carlo simulations, and statistical methods. Nevertheless, due to their simplicity in comprehension and communication and the less

demanding computational effort they require, deterministic project duration forecasting techniques still play a significant role in project management practice nowadays (Ballesteros-Pérez, P., Sanz-Ablanedo, E., Mora-Melià, D., González-Cruz, M. C., Fuentes-Bargues, J. L., & Pellicer, E., 2019). One of the most recent studies on the matter was conducted in 2019 by Ballesteros-Pérez et al., with the aim to provide numerical evidence on which deterministic EVM extensions and metrics are more accurate at predicting the real duration of a project. Surprisingly, what they discovered was that, among the several methodologies proposed over the years, including the ED method, PV method, ES, and EDM, the Earned Schedule represented the most reliable metric for TEAC estimation. Therefore, they found that while EDM outperformed ES in schedule monitoring and early warning signaling by untying time performance metrics from EV, it could not manage to better predict project outcomes. Concerned by this discrepancy, Ballesteros-Pérez et al (2019b) decided to introduce an approach based on two new metrics, ES_{\min} and ES_{\max} , that could at the same time overcome ES's reliance on Earned Value while further improving its forecasting accuracy. The use of these metrics was later compared to the other discussed methodologies, ultimately proving to perform better in predicting the TEAC. In particular, the proposed approach works as follows:

- Earned Schedule of activity i (ES_i): For calculating ES_{\min} and ES_{\max} , it is necessary to calculate beforehand the Earned Schedule value of each activity i (noted as ES_i) at the current tracking period AT (Ballesteros-Pérez, P., Sanz-Ablanedo, E., Mora-Melià, D., González-Cruz, M. C., Fuentes-Bargues, J. L., & Pellicer, E., 2019). The calculation is quite simple:

$$ES_i = SD_i + PC_i \cdot d_i \quad (42)$$

Where SD_i represents activity i 's earliest start date, PC_i its percentage completion at the tracking period AT , and d_i its planned duration (Ballesteros-Pérez, P., Sanz-Ablanedo, E., Mora-Melià, D., González-Cruz, M. C., Fuentes-Bargues, J. L., & Pellicer, E., 2019). It is to be noted that, in order for the formula to work properly, it is necessary to express SD_i and d_i in terms of working days and not calendar days.

- Earned Schedule min (ES_{min}): This metric is calculated as the minimum ES_i of all unfinished activities, that is, all those activities with a percentage completion below 100% (Ballesteros-Pérez, P., Sanz-Ablanedo, E., Mora-Melià, D., González-Cruz, M. C., Fuentes-Bargues, J. L., & Pellicer, E., 2019). The ES_{min} formula is the following:

$$ES_{min} = \min \{ ES_i + s_i : PC_i \in [0,1), i \in n \} \quad (43)$$

where s_i is activity i 's (baseline) slack, i.e., its Total Float (See formula (2)), while n denotes the set of all activities in the project. It is important to note that, the inclusion of s_i in the expression means that the formula utilizes the latest start dates of activities.

- Earned Schedule max (ES_{max}): ES_{max} is calculated as the maximum ES_i value of those activities that have already started, i.e., all those activities with a percentage completion above 0%:

$$ES_{max} = \max \{ ES_i : PC_i \in (0,1], i \in n \} \quad (44)$$

Although it is not quite immediate to notice, by looking more deeply at the formulas it appears evident that what they are doing is calculating the equivalent planned date of progress of the most delayed (ES_{min}) and most advanced paths (ES_{max}) (Ballesteros-Pérez, P., Sanz-Ablanedo, E., Mora-Melià, D., González-Cruz, M. C., Fuentes-Bargues, J. L., & Pellicer, E., 2019). To better

understand this concept and show in practice how all these metrics are computed, a simple yet effective illustration of them is shown below in Figure 4.11:

Figure 4.11 ES_{min} and ES_{max} calculation example

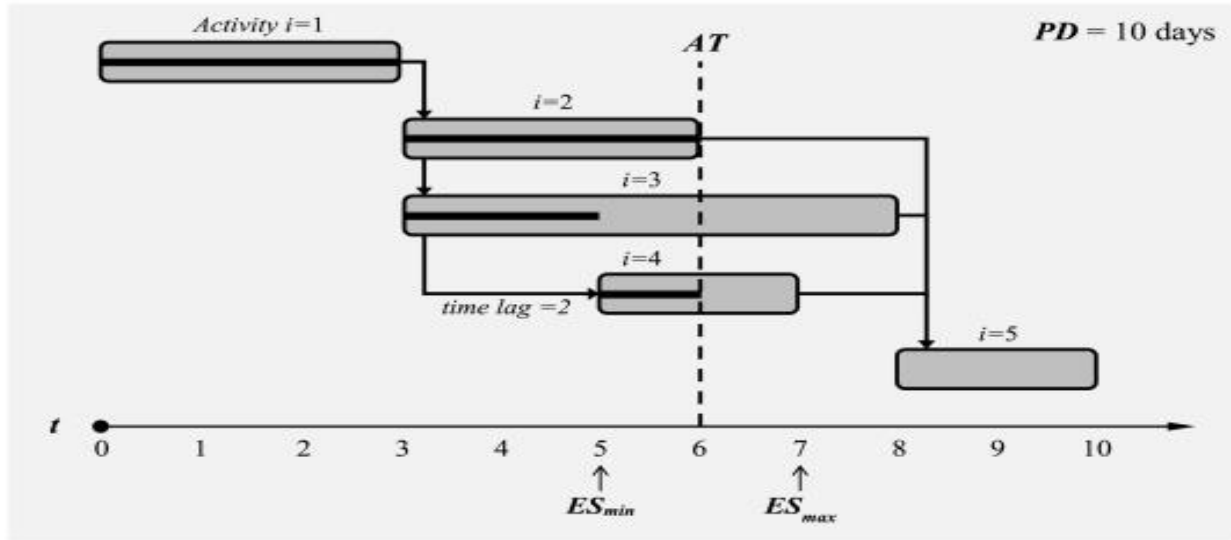

Activity (i)	Predecessors	SD_i (days)	d_i (days)	s_i (days)	PC_i (%)	ES_i (days)	ES_{min} (days)	ES_{max} (days)
1	-	0	3	0	1.00	3	-	3
2	FS1	3	3	2	1.00	6	-	6
3	FS1	3	5	0	0.40	5	5+0	5
4	FS1+2d	5	2	1	1.00	7	-	7
5	FS2,FS3,FS4	8	2	0	0.00	8	8+0	-

$ES_{min}=5$ $ES_{max}=7$

Ballesteros-Pérez, P., Sanz-Ablanedo, E., Mora-Melià, D., González-Cruz, M. C., Fuentes-Bargues, J. L., & Pellicer, E., 2019

Finally, ES_{min} and ES_{max} can be used to forecast the Time Estimate At Completion (TEAC) as follows:

$$TEAC(t)_{ES_{min}} = AT + PD - ES_{min} \quad (45)$$

$$TEAC(t)_{ES_{max}} = AT + PD - ES_{max} \quad (46)$$

As anticipated, these metrics proved to actually outperform ES in project duration forecasting, thus providing managers with a simple but highly effective approach to understanding the likely outcome of their projects. Nevertheless, this method demonstrated several further advantages and applications. Firstly, given that ES_{min} and ES_{max} determine the planned progress dates of the most delayed and advanced paths, it can be inferred that $TEAC(t)_{ES_{min}}$ constitutes an average upper-bound of the project duration, while $TEAC(t)_{ES_{max}}$ serves as an average lower-bound (Ballesteros-Pérez, P., Sanz-Ablanedo, E., Mora-Melià, D., González-Cruz, M. C., Fuentes-Bargues, J. L., & Pellicer, E., 2019). In real-life projects, hence, the actual project duration is likely to remain between these two boundaries most of the time, providing managers with a range of possible durations they would not have with other deterministic EVM-based approaches. Additionally, ES_{min} and ES_{max} can be used to better allocate resources to activities during project execution (Ballesteros-Pérez, P., Sanz-Ablanedo, E., Mora-Melià, D., González-Cruz, M. C., Fuentes-Bargues, J. L., & Pellicer, E., 2019). Indeed, activities whose ES_i coincides with ES_{min} represent bottleneck activities, and when the project requires realignment or acceleration, logically resources need to be mobilized toward them. Such resources, in turn, should be taken off those activities whose ES_i coincides with ES_{max} , as they represent the least critical ones in the network. Finally, since they do not rely on EVM metrics, ES_{min} and ES_{max} can also be completely decoupled from the EVM framework and be used with any other project management framework, such as the Earned Duration Methodology (Ballesteros-Pérez, P., Sanz-Ablanedo, E., Mora-Melià, D., González-Cruz, M. C., Fuentes-Bargues, J. L., & Pellicer, E., 2019). Given what was stated at the beginning of this section and throughout the chapter so far, it is evident how this flexibility can represent a major turning point for schedule monitoring.

4.2 Bottom-up Project Control

Unlike traditional EVM-based performance measurement systems, a bottom-up project control technique collects data from lower levels of the Work Breakdown Structure (WBS). Gathering information at lower WBS levels, typically at the activity level, is necessary in case EVM is not applied or does not provide reliable project performance indices, but often demands a stronger control of a larger subset of activities and a continuous critical path-based tracking decision process compared to the quick performance check obtained by EVM (Vanhoucke, M., 2011). This level of control necessitates collecting detailed information about individual activities to effectively manage project tracking and make corrective decisions to enhance overall project performance. Therefore, the bottom-up approach assumes that only a subset of all project activities deserves attention during a project's progress, and only controls the performance of activities above a certain sensitivity threshold that, in case of delays, are subject to corrective actions. (Vanhoucke, M., 2011). The development of this approach was mainly motivated by the common knowledge that deterministic critical path analyses, on which traditional top-down control relies, give an optimistic project duration estimate. Moreover, in such cases a delay in a non-critical activity might erroneously signal that the project is in trouble, even if there is no real issue because the activity still has some float left. Hence, calculating performance measures at the project level can lead to false alarms and incorrect corrective actions. Finally, when considering the effects of uncertainty, the concept of a unique critical path no longer holds validity. Indeed, it is not surprising that variations in activities' duration may lead to the emergence of a critical path that differs from the original estimate, impacting both the project duration and the path's configuration. Therefore, it becomes imperative to monitor each individual activity to accurately gauge its specific impact on the project's timeline.

A well-known bottom-up approach is Schedule Risk Analysis (SRA), which determines the significance of individual project activities thus providing general direction indicators of where the focus of a project manager should be. Specifically, Schedule Risk Analysis is a technique that refines traditional critical path-based project control by considering degrees of criticality and risk. Indeed, it connects the risk information of project activities to the baseline schedule and provides sensitivity information of individual project activities as a way to assess the potential impact of uncertainty on the final project duration, enabling the project manager to gauge an activity's significance to the project's objectives. (Vanhoucke, M., 2016). Schedule Risk Analysis encompasses four main steps, as depicted in Figure 4.12 below (Vanhoucke, M., 2016):

- **Baseline Schedule:** The construction of a project baseline schedule involves the definition of a set of variables for each project activity, such as start and finish times and floats. Review section 2.2.1, discussing the typical process followed to conduct this step.
- **Define Risk/Uncertainty:** Subsequently, it is necessary to consider the implications of uncertainty and variability on each activity. Although statistical distributions might be computed for all activity, this is often considered too demanding and time-consuming. Therefore, this is typically accomplished by using three-point estimates, representing the pessimistic, most likely, and optimistic value for the activity's duration, which culminates in a triangular distribution like the one shown in section 4.1.6 for Triangle Fuzzy Numbers.
- **Monte Carlo Simulations:** During each simulation run, the simulation engine records all project schedules and critical paths during progress in order to be able to measure the degree of activity sensitivity and the expected impact of activity variation on the project objective (Vanhoucke, M., 2016). Monte Carlo simulation is consistently favored in

Schedule Risk Analysis (SRA) for this task due to its effectiveness and simplicity, although statistical speculations could be used also in this step.

- **Sensitivity Results:** The outcome of a schedule risk analysis produces a set of metrics that elucidate the level of activity criticality and sensitivity, moving beyond a binary assessment of whether an activity is critical or not on the critical path. These metrics provide project managers with insights into the activity's impact on the final project duration, and their values become accessible after the simulation run, serving as signals to prioritize attention on activities that may pose higher risks and require increased focus for successful project completion.

Figure 4.12 Schedule Risk Analysis four steps

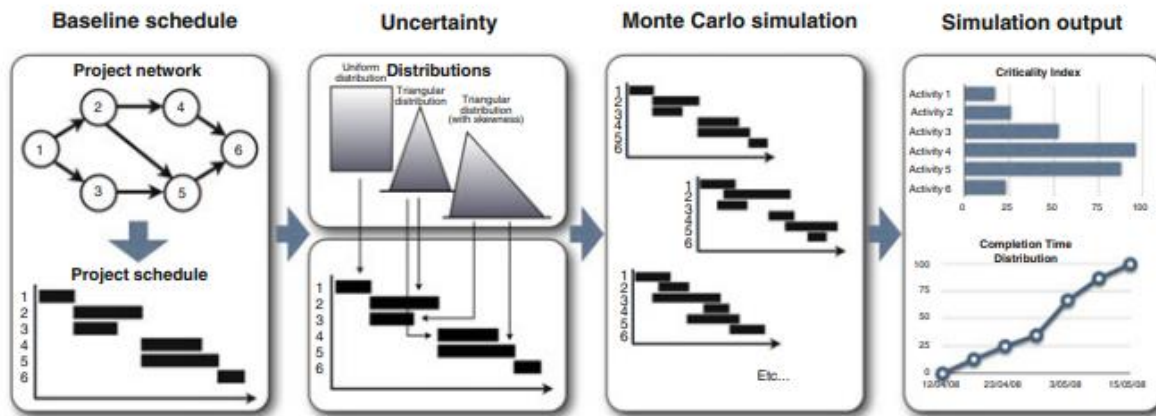

Vanhoucke, M., 2016

Over the years, SRA has produced a series of metrics that allow the activities that are more critical than others to be discriminated against mathematically. Basically, these metrics assign a numerical value, typically between 0 and 1, to rank activities based on their importance, enabling project managers to set a comparative numerical threshold that can be adjusted as the project progresses. All activities whose metric value exceeds the threshold should be monitored more

closely during execution. (Ballesteros-Pérez, P., Cerezo-Narváez, A., Otero-Mateo, M., Pastor-Fernández, A., & Vanhoucke, M., 2019). These indexes are generally divided into two main categories based on the approach employed in their calculation: analytical-based and simulation-based indexes. Although analytical approaches have been widely explored, their practical application is limited due to their high computational requirements, in contrast to the more commonly utilized, faster, and comparably effective simulation-based methods executed through Monte Carlo simulations. (SRA, SpringerLink). Therefore, mainly simulation-based indexes will be discussed in this chapter. In particular, the indexes discussed are the Criticality Index (CI), Significance Index (SI), Cruciality Index (CRI), Schedule Sensitivity Index (SSI), Uncertainty Importance Measure of Activities (UIMA), Management Oriented Index (MOI), and Criticality-Slack-Sensitivity index (CSS). Furthermore, relevant studies exploring the sensitivity of project mean duration and variance to change in specific activities' mean duration and variance are discussed. Although some of these studies do not propose specific indices for measuring these relationships, their contribution is significant, as they allow managers to select those activities that are more impactful on the project, thus narrowing their focus and allocating their efforts more effectively throughout project execution.

The following notation will be employed throughout this paragraph:

Table 4.1. Notation

TF_i	Total Float of activity i
d	Duration of activity i
C_{max}	Project total duration
TF_i^k	Total Float of activity i in run k

d_i^k	Duration of activity i in run k
C_{max}^k	Project total duration in run k
\overline{TF}_i	Arithmetic mean on k of total float of activity i
\bar{d}_i	Arithmetic mean on k of duration of activity i
\bar{C}_{max}	Arithmetic mean on k of total project duration
s_{d_i}	Standard deviation of activity i
$s_{C_{max}}$	Standard deviation of total project duration

Finally, a sample project will be employed to provide the reader with practical calculations of the indexes introduced. Figure 4.13 illustrates the project's network, which is composed of eight activities; the sequence of activities 1-2-5-8 forms the deterministic critical path, and the project is scheduled to take 90 days. Conversely, Table 4.2 presents the outcomes of ten Monte Carlo simulation iterations for the project, detailing for each run the durations of all activities (d_i), the project duration (C_{max}), the Critical Path (CP), and the Total Float for all activities (TF_i). Furthermore, the average for the duration of activity i (\bar{d}_i), project duration (\bar{C}_{max}), and Total Float for activity i (\overline{TF}_i) are reported in the last row. It is important to remember that this serves exclusively as a practical example and that the number of simulation runs should far exceed to provide reliable results.

Figure 4.13 Sample Project for indexes calculations

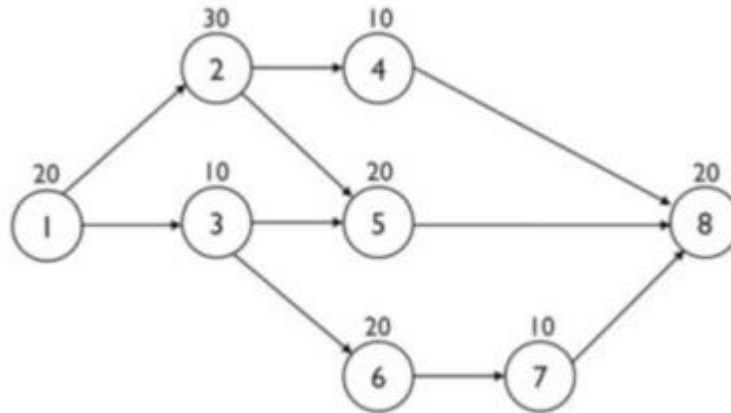

Vanhoucke, M., 2016

Table 4.2. Simulation runs results for sample project

	d_i								C_{max}	CP	TF_i
	1	2	3	4	5	6	7	8			
Run 1	4	12	1	4	5	4	7	8	29	1-2-5-8	0-0-5-1-0-5-5-0
Run 2	22	23	14	5	28	26	5	29	102	1-2-5-8	0-0-6-23-0-6-6-0
Run 3	25	38	12	15	24	20	13	22	109	1-2-5-8	0-0-17-9-0-17-17-0
Run 4	25	25	15	13	25	25	13	10	88	1-3-6-7-8	0-3-0-15-3-0-0-0
Run 5	21	42	12	7	30	21	14	23	116	1-2-5-8	0-0-25-23-0-25-25-0
Run 6	28	44	7	9	15	20	10	22	109	1-2-5-8	0-0-22-6-0-22-22-0
Run 7	19	21	14	13	23	24	14	28	99	1-3-6-7-8	0-8-0-18-8-0-0-0
Run 8	12	36	14	9	19	17	7	24	91	1-2-5-8	0-0-17-10-0-17-17-0
Run 9	28	35	7	12	28	27	13	28	119	1-2-5-8	0-0-16-16-0-16-16-0
Run 10	27	44	6	5	30	10	11	28	129	1-2-5-8	0-0-38-25-0-47-47-0
Avg	21.1	32	10.2	9.2	22.7	19.4	10.7	22.2	99.1		0-1.1-15.1-14.6-1.1-15.5-15.5-0

4.2.1 Van Slyke, R. M. (1963). Monte Carlo Methods and the PERT Problem.

The first sensitivity metrics was introduced in 1963 by Van Slycke to address a significant limitation of using deterministic durations in project scheduling. What he pointed out was that while traditional scheduling culminated in the definition of a unique critical path, indicating those activities that require the most attention during project execution, this could not be the case when considering the inherent variability of activities durations. In general, any of a number of paths could be critical, depending on the particular realization of the random activity durations that actually occurs (Van Slyke, R. M., 1963). Indeed, the existence of a distinct critical path might only be plausible in the unlikely event that the durations of all non-critical activities were irrelevant when compared to those of critical ones. However, this is frequently not the case, and it is not uncommon that non-critical tasks' durations are only marginally shorter than those of critical ones. Thus, it makes sense to talk about a Criticality Index (CI), which is simply the probability that an activity will be on the critical path (Van Slyke, R. M., 1963). The CI is typically obtained by Monte Carlo simulations, and is generally expressed as a percentage through the following equation:

$$CI_i = \text{Prob}(TF_i = 0) \quad (47)$$

Where TF_i is the Total Float of activity i . More specifically, to compute the CI on simulation-based measures, the following formula is applied:

$$CI_i = \frac{1}{nrs} \sum_{k=1}^{nrs} \mathbf{1}(TF_i^k = 0) \quad (48)$$

Where nrs is the number of Monte Carlo simulation runs, and the function $\mathbf{1}(x)$ is defined by:

$$\mathbf{1}(x) = \begin{cases} 1, & \text{if } x \text{ is true} \\ 0, & \text{if } x \text{ is false} \end{cases} \quad (49)$$

To give an example, consider the CP column shown in Table 4.2. Activity 1 lies on the critical path in ten out of ten runs, thus having a criticality of 100%, while activity 2 lies on the critical path (CP) only 8 times, thus having a $CI_2 = 80\%$. Overall, the purpose of CI is to provide managers with the relevance that each activity has on the timely completion of the project, thus allowing them not to over rely on an unrealistic unique critical path.

4.2.2 Williams, T. M. (1993). *Criticality in Stochastic Networks*.

In 1993, Williams criticized the use of CI due to its inadequacy in measuring project risk and non-intuitive nature, proposing two new metrics as possible solutions: the Significance Index (SI) and Cruciality Index (CRI). Indeed, the CI often fails in adequately measuring the project risk because its focus is restricted to measuring probability, which does not necessarily mean that high CI activities have a high impact on the total project duration (e.g., think of a very low duration activity always lying on the critical path, but with a low impact on the total project duration due to its negligible duration) (Vanhoucke, M., 2016). Moreover, managers would find it more beneficial to possess a metric that conveys the relative significance of individual activities in the context of the overall project duration. This understanding can guide them in allocating monitoring efforts effectively, rather than solely relying on probability as a measure of criticality.

The Significance Index (SI) aims to reflect the relative importance between project activities as follows:

$$SI_i = E\left(\frac{d_i}{d_i + TF_i} \cdot \frac{C_{max}}{E(C_{max})}\right) \quad (50)$$

As before, the formula can be adapted to simulation-based measurements as follows:

$$SI_i = \frac{1}{nrs} \sum_{k=1}^{nrs} \left(\frac{d_i^k}{d_i^k + TF_i^k} \cdot \frac{C_{max}^k}{\bar{C}_{max}} \right) \quad (51)$$

It is to be noted that this formula considers two key factors in each run k to assess the significance of an activity. On one hand, when the TF of an activity increases, its relevance decreases, as the higher the TF the lower the activity's impact on the duration of the entire project. On the other hand, the SI is greater when the project duration in run k exceeds its average duration across all runs (k), as these scenarios are considered riskier. An example of SI_i calculations for activity 2 is provided in Table 4.3:

Table 4.3. Significance Index calculations for activity 2

	$d_i^k * C_{max}^k$	$d_i^k + TF_i^k$	$\frac{(d_i^k * C_{max}^k)}{[C_{max} (d_i^k + TF_i^k)]}$
Run 1	348	12	0.29
Run 2	2,346	23	1.03
Run 3	4,142	38	1.10
Run 4	2,200	28	0.79
Run 5	4,872	42	1.17
Run 6	4,796	44	1.10
Run 7	2,079	29	0.72
Run 8	3,276	36	0.92
Run 9	4,165	35	1.20
Run 10	5,676	44	1.30
SUM	33900	331	9.62

Although this activity lies on the critical path in the baseline schedule, the significance index shows that the SI of this activity is 0.962 and not one, proving again the need not to over-rely on deterministic and fixed schedules.

Overall, the SI has been defined as a partial answer to the criticism of the CI. Rather than expressing an activity's criticality by the probability concept, the SI aims at exposing the significance of individual activities on the total project duration. In some examples, the SI seems to provide more acceptable information on the relative importance of activities. Despite this, there are still examples where counter-intuitive results are reported (Vanhoucke, M., 2016).

The Cruciality Index (CRI), on the other hand, aims to reflect the relative importance of an activity in a more intuitive way by measuring the portion of total project duration uncertainty that can be explained by the uncertainty of an activity. Specifically, in this case, the duration sensitivity of individual activities on the total project duration is given by the correlation between the activity duration and total project duration (Vanhoucke, M., 2010):

$$CRI_i = \text{Corr}(d_i, C_{\max}) \quad (52)$$

This measure can be calculated through three different approaches:

- Pearson's product-moment CRI(r): This is a traditional measure of the degree of linear relationship between two variables (Vanhoucke, M., 2016). The correlation is 1 in the case of a clear positive linear relationship, -1 in the case of a clear negative linear relationship, and some value in between in all other cases, indicating the degree of linear dependence between the activity duration and the total project duration. In general, the cruciality index based on the Pearson product-moment is given by:

$$CRI(r) = \frac{\text{Cov}(d_i, C_{\max})}{\text{Var}(d_i) \text{Var}(C_{\max})} \quad (53)$$

While a simulation-based estimator is computed as follows:

$$CRI(r) = \frac{\sum_{k=1}^{nrs} (d_i^k - \bar{d}_i)(C_{\max}^k - \bar{C}_{\max})}{(nrs-1)s_{d_i} s_{C_{\max}}} \quad (54)$$

With s_{d_i} and $s_{C_{\max}}$ the sample standard deviations of variables d_i and C_{\max} , given by

$$s_{d_i} = \sqrt{\frac{\sum_{k=1}^{nrs} (d_i^k - \bar{d}_i)^2}{nrs-1}} \quad \text{and} \quad s_{C_{\max}} = \sqrt{\frac{\sum_{k=1}^{nrs} (C_{\max}^k - \bar{C}_{\max})^2}{nrs-1}} \quad (55)$$

An example of CRI(r) intermediate calculations for activity 2 is provided below in Table 4.4. According to the values shown, the CRI(r) of activity 2 is then computed as follows:

$$\text{CRI}(r)_2 = 2188/(1100*6882.9)^{0.5} = 0.8$$

However, it is important to note that while this correlation metric measures the degree of linear relationship between two variables, it is not obvious that the relationship between an activity's duration and the total project duration always adheres to a linear pattern. For instance, in some cases the impact of d_i on C_{max} gets more significant as d_i increases, meaning that there is a non-linear relationship between these two variables. Therefore, non-linear correlation measures such as the Spearman Rank correlation coefficient or Kendall's tau measure have been proposed to overcome such assumption.

Table 4.4. Pearson's Cruciality Index calculations for activity 2

	$(d_i^k - \bar{d}_i)^2$	$(C_{max}^k - \bar{C}_{max})^2$	$(d_i^k - \bar{d}_i) * (C_{max}^k - \bar{C}_{max})$
Run 1	400	4,914.01	1,402.0
Run 2	81	8.41	-26.1
Run 3	36	98.01	59.4
Run 4	49	123.21	77.7
Run 5	100	285.61	169.0
Run 6	144	98.01	118.8
Run 7	121	0.01	1.1
Run 8	16	65.61	-32.4
Run 9	9	396.01	59.7
Run 10	144	894.01	358.8
SUM	1,100	6,882.90	2,188.0

- Spearman's rank CRI(ρ): In this case, the values for the variables are converted to ranks, followed by the calculation of the difference between the ranks of each observation of the two variables (Vanhoucke, M., 2016):

$$\text{CRI}(\rho) = 1 - \frac{6 \sum_{k=1}^{nrs} \delta_k^2}{nrs (nrs^2 - 1)} \quad (56)$$

Where δ^k is the difference between the ranking values of d_i and C_{max} during simulation k :

$$\delta^k = \text{rank}(d_i) - \text{rank}(c_{max}) \text{ for } k = 1, \dots, nrs \quad (57)$$

It is important to note that the ranking goes from 1 up starting from the lowest duration (e.g., run 1 Table 4.5), and in case of tie breaks the average of the ranking values is calculated (e.g., run 6 and 10 Table 4.5). To give an example, the intermediate calculations of $\text{CRI}(\rho)$ for activity 2 are provided below in Table 4.5, which is then computed as:

$$\text{CRI}(\rho)_2 = 1 - (6*46.5) / [10*(10^2-1)] = 0.72$$

Table 4.5. Spearman's Cruciality Index calculations for activity 2

	Ranking value for d_i of activity 2	Ranking value for C_{max}	δ_k^2
Run 1	1	1	0
Run 2	3	5	4
Run 3	7	6.5	0.25
Run 4	4	2	4
Run 5	8	8	0
Run 6	9.5	6.5	9
Run 7	2	4	4
Run 8	6	3	9
Run 9	5	9	16
Run 10	9.5	10	0.25
SUM			46.50

- Kendall's tau rank $\text{CRI}(\tau)$: In this case, the values for the variables are converted to ranks, but the index is measured as the degree of correspondence between two rankings:

$$\text{CRI}(\tau) = \left[\frac{4}{nrs(nrs-1)} \sum_{k=1}^{nrs-1} \sum_{l=k+1}^{nrs} \mathbf{1}\{ (d_i^l - d_i^k) (C_{max}^l - C_{max}^k) > 0 \} \right] - 1 \quad (58)$$

That is, for each activity i a comparison of activity and project duration values between all the simulation runs is performed. To give an example, for activity 2 the first comparison would be between simulations 1 and 2, with a value of $\mathbf{1}[(12 - 23)(29 - 102) > 0] = 1$.

The same must be done for runs 1 and 3, 1 and 4, and so on up to runs 9 and 10. Specifically, simulation run 1 will be compared with all 9 others, simulation run 2 will only be compared with 8 other simulation runs, and so forth, obtaining a total of 45 combinations. Therefore, for activity 2, the sum of $\mathbf{1}(x)$ for each simulation run is:

- Simulation run 1: 9 (of 9)
- Simulation run 2: 6 (of 8)
- Simulation run 3: 5 (of 7)
- Simulation run 4: 5 (of 6)
- Simulation run 5: 3 (of 5)
- Simulation run 6: 2 (of 4)
- Simulation run 7: 2 (of 3)
- Simulation run 8: 1 (of 2)
- Simulation run 9: 1 (of 1)

With a total sum equal to 34, the $\text{CRI}(\tau)$ is easily computed as:

$$\text{CRI}(\tau)_2 = (4 \cdot 34) / (10 \cdot 9) - 1 = 0.51$$

4.2.3 Cho, J. G., & Yum, B. J. (1997). An uncertainty importance measure of activities in Pert Networks.

In 1997, Cho and Yum further developed the concepts introduced previously by Williams. Although they stressed again the need to measure the uncertainty importance of an activity to identify those that deserve more attention in reducing the magnitude of the uncertainty in total project duration, they pointed out two main limitations of the proposed CRI in performing such a measurement. Firstly, evaluating the linear or nonlinear correlation between an activity duration d_i and the project duration C_{\max} may be computationally demanding. In addition, these measures

cannot be easily extended to accommodate the case where, for instance, two activity durations have an interaction effect on C_{max} (Cho, J. G., & Yum, B. J., 1997). For these reasons, they introduced a new metric: the Uncertainty Importance Measure of Activities (UIMA). The UIMA works under the assumption that the durations of activities are independent and symmetrically distributed, and is generally defined for a single and a pair of activities as follows:

$$UIMA_i = \frac{\text{Variability of } C_{max} \text{ due to the uncertainty in } d_i}{\text{Total variability of } C_{max}} \quad (59)$$

$$UIMA_{i,j} = \frac{\text{Variability of } C_{max} \text{ due to the uncertainty in } d_i \text{ and } d_j}{\text{Total variability of } C_{max}} \quad (60)$$

$UIMA_i$ in equation (59) evaluates the so called main effect of d_i on the variability of C_{max} while $UIMA_{i,j}$ in equation (60) evaluates the combined main effects and interaction effect on C_{max} of the uncertainties in d_i and d_j (Cho, J. G., & Yum, B. J., 1997).

To understand how variations in the variability of an activity may impact the variability of the entire project, it is important to consider some characteristics of project networks. Consider a project network comprising three possible paths and five activities. Three typical scenarios emerge (Cho, J. G., & Yum, B. J., 1997):

- Case (a): one path is much longer than the other two
- Case (b): one path is slightly longer than the other two
- Case (c): all paths have the same length

After analyzing the effects on the project duration C_{max} of variations in the duration of an activity, in this case activity 1, the following graph (Figure 4.14) emerges (note that C_{max} is denoted as T , while d_1 as t_1):

Figure 4.14 Effects on the project duration of variations in the duration of an activity

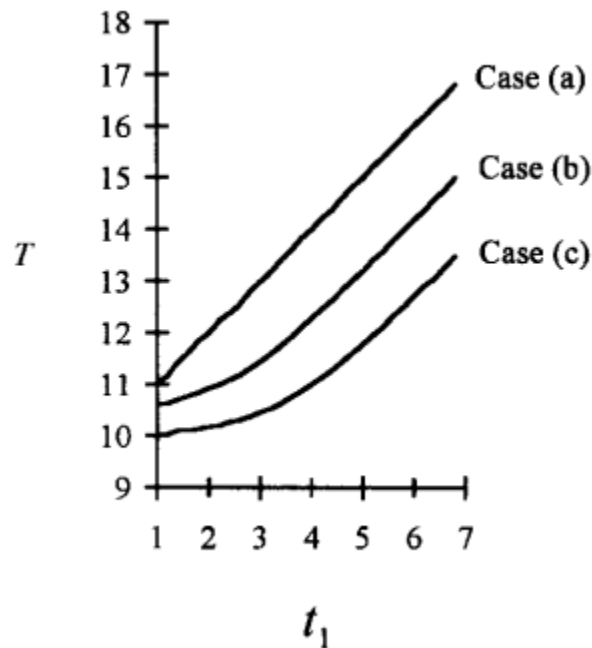

Cho, J. G., & Yum, B. J., 1997

Therefore, the following considerations can be made:

- If a dominantly longer path P exists in the network (case (a)), activities not on P have negligible effects on T , while the activities on P have a linear effect on T (Cho, J. G., & Yum, B. J., 1997)
- If the durations of the competing critical paths are similar (case (b) and (c)), the duration of each activity in the paths exhibits a curvature effect on T (Cho, J. G., & Yum, B. J., 1997). Indeed, as the duration of an activity increases, it tends to become critical, leading to a higher C_{max} . This effect is more pronounced when there are more critical paths (e.g., more prominent in case (c) than (b)), as a longer activity duration is required for the corresponding competing path to become critical. (Cho, J. G., & Yum, B. J., 1997).

- Even though the durations of the competing critical paths are similar, the effect on C_{\max} of the duration of each activity on the paths tends to be linear as the number of activities constituting the paths increases, as C_{\max} would not be seriously affected by the duration of a single activity on a path if it consists of many activities (Cho, J. G., & Yum, B. J., 1997).

Furthermore, the impact of the variability in the duration of activity i on C_{\max} may be influenced by the variability in the duration of another activity j . While this effect is negligible when a predominant path exists (case (a)), it can be significant when that is not the case. To give an example, Cho and Yum (1997) analyzed how a different value of the duration of activity 2 d_2 in case (c) influences the relation between d_1 and C_{\max} . The result is shown in Figure 4.15 below:

Figure 4.15 Interaction between activities durations example

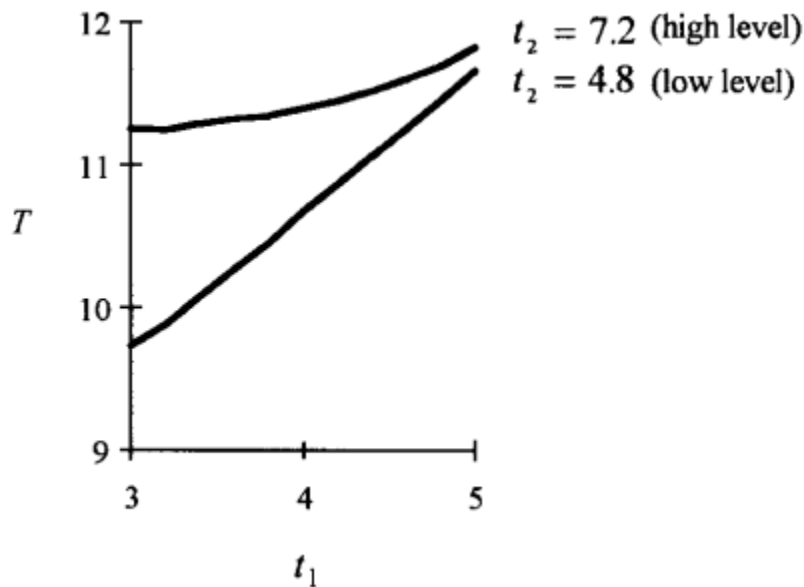

Cho, J. G., & Yum, B. J., 1997

Following these considerations, Cho and Yum (1997) defined the UIMA indexes for two different network types, i.e., type-A and type-B networks. The authors proposed a two-step procedure,

namely, identifying the competing critical paths, and then comparing their path durations (Cho, J. G., & Yum, B. J., 1997). This paper does not delve into the specifics of this methodology, but a comprehensive explanation can be found in the authors' original article. UIMA is calculated based on the path identified for a particular project as follows:

- Type-A network: Type-A networks are the ones where a predominantly longer path P is present. In this case, the activities not on the dominantly longer path have negligible effects on T, while the activities on the dominantly longer path have linear effects on T and do not have any significant interactions with each other (Cho, J. G., & Yum, B. J., 1997).

Therefore. UIMA can be computed as:

$$UIMA_i = \frac{Var(i)}{Var(C_{max})} \quad (61)$$

Where, $Var(C_{max}) = \sum_{i \in P} Var(i)$. Obviously, for a simulation-based indicator, formula (61) becomes:

$$UIMA_i = \frac{s_{d_i}^2}{s_{C_{max}}^2} \quad (62)$$

- Type-B network: Type-B networks are the ones where no predominantly longer path is present. In such cases, some activity durations may have curvature effects on C_{max} , and significant interactions may exist between activity durations (Cho, J. G., & Yum, B. J., 1997). To evaluate these networks, Cho and Yum (1997) crafted a technique that utilizes the concept of the Taguchi tolerance design. However, a comprehensive exposition of this methodology is beyond the scope of this paper and is consequently not included. Additionally, it is worth noting that while $UIMA_{i,j}$ in equation (60) could be easily extended to the case of more than two activities, interaction effects among three or more activity

durations are usually negligible in magnitude in most practical problems (Cho, J. G., & Yum, B. J., 1997).

4.2.4 Gutierrez, G., & Paul, A. (1998). Analysis of the effects of uncertainty, risk-pooling, and subcontracting mechanisms on project performance.

Following the previous studies, Gutierrez and Paul (1998) analyzed the effect of changes in the variability of an activity on the mean duration of project completion time. Specifically, their study examined these effects across two main types of project networks, akin to the previously identified type-A and type-B networks. In general, when the project consists of serial, independent activities, there is no connection between activity variability and expected project completion (Gutierrez, G., & Paul, A., 1998). However, when there are more activities in parallel the situation is different. Contrary to the initial assumption that increased variability in any activity would invariably lead to longer project durations, Gutierrez and Paul (1998) found exceptions to this rule. In certain cases, they observed that heightened variability in an activity could actually shorten the average duration of the project, especially when the activities have more than three possible outcomes (e.g., an activity that can only take 1, 2, or 3 days to complete). In these scenarios, increasing the variability of an activity actually leads to a decrease in the expected project duration. This happens because, with more variability, there's also a chance that the activity might finish quicker than expected, which can sometimes outweigh the chances of it taking longer. Furthermore, the research conducted led the authors to the following significant results:

- The greater the variability of the project activities in the sense of the increasing convex order, the greater the expected project completion time of a project network (Gutierrez, G., & Paul, A., 1998). Convex order is primarily concerned with the overall spread or variability of outcomes: if an activity's completion time is described by a random variable

with a higher convex order, it means there's a broader range of possible completion times, thus making it harder to predict exactly how long the activity will take.

- The greater the variability of the project activities in the sense of the convex order, the more the expected critical path length in a project network underestimates the actual expected project completion time (Gutierrez, G., & Paul, A., 1998). When an activity's completion time has a higher increasing convex order, it suggests that as the potential completion times get longer, the uncertainty or variability in these times increases more significantly, i.e., it indicates that longer delays might be even more unpredictable than shorter ones.

To sum up, when activities have more than three possible durations, the variability becomes more complex, leading to scenarios where increased variability can sometimes shorten the project duration. However, generally, higher variability in the sense of increasing convex order tends to increase project duration, while higher variability in convex order makes it more likely to underestimate the project duration.

The study by Gutierrez and Paul (1998) provides essential insights for project managers, particularly in enhancing risk management through the identification of high-variability activities that could significantly impact project timelines. This knowledge proves invaluable in optimizing resource allocation and directing focus toward these high-variability activities. Moreover, these findings facilitate more accurate project planning, enabling managers to develop realistic schedules that comprehensively account for variability, a factor that is especially crucial in projects with parallel activities.

4.2.5 Elmalghraby, S. E., Fathi, Y., & Taner, M. R. (1998). On the sensitivity of project variability to activity mean duration.

After Cho and Yum (1997) analyzed the effect of activity variability on project variability, and Guitierrez and Paul (1998) the effect of activity variability on project mean duration, Elmalghraby et al. (1998) studied the sensitivity of project variance to the mean duration of an activity. This analysis is conducted considering two cases by changing the mean of each activity duration in two cases: while keeping its variance constant and while maintaining a constant coefficient of variation. As before, different activities of a fictitious project were analyzed to categorize the issue.

In the former case, the study led to the following results, which can be visually appreciated in Figure 4.16 below:

- The variance of the project duration is not affected by increasing the mean of the activity duration until the mean reaches a certain 'threshold' level, beyond which the project variance starts to change with the mean of the activity duration as it is increased further, and, after some point, it stabilizes to a constant value (Elmalghraby, S. E., Fathi, Y., & Taner, M. R., 1998).
- Increasing the mean of some activity duration reduces the variance of the project duration (Figure 4.16.a), while increasing the mean of some other activity duration increases the variance of the project duration (Figure 4.16.b), and yet increasing the mean of some activity's duration causes the variance of the project duration to fluctuate (Figure 4.16.c) (Elmalghraby, S. E., Fathi, Y., & Taner, M. R., 1998).

Figure 4.16 Changes in project variance with changes in mean duration of activity
(constant activity variance)

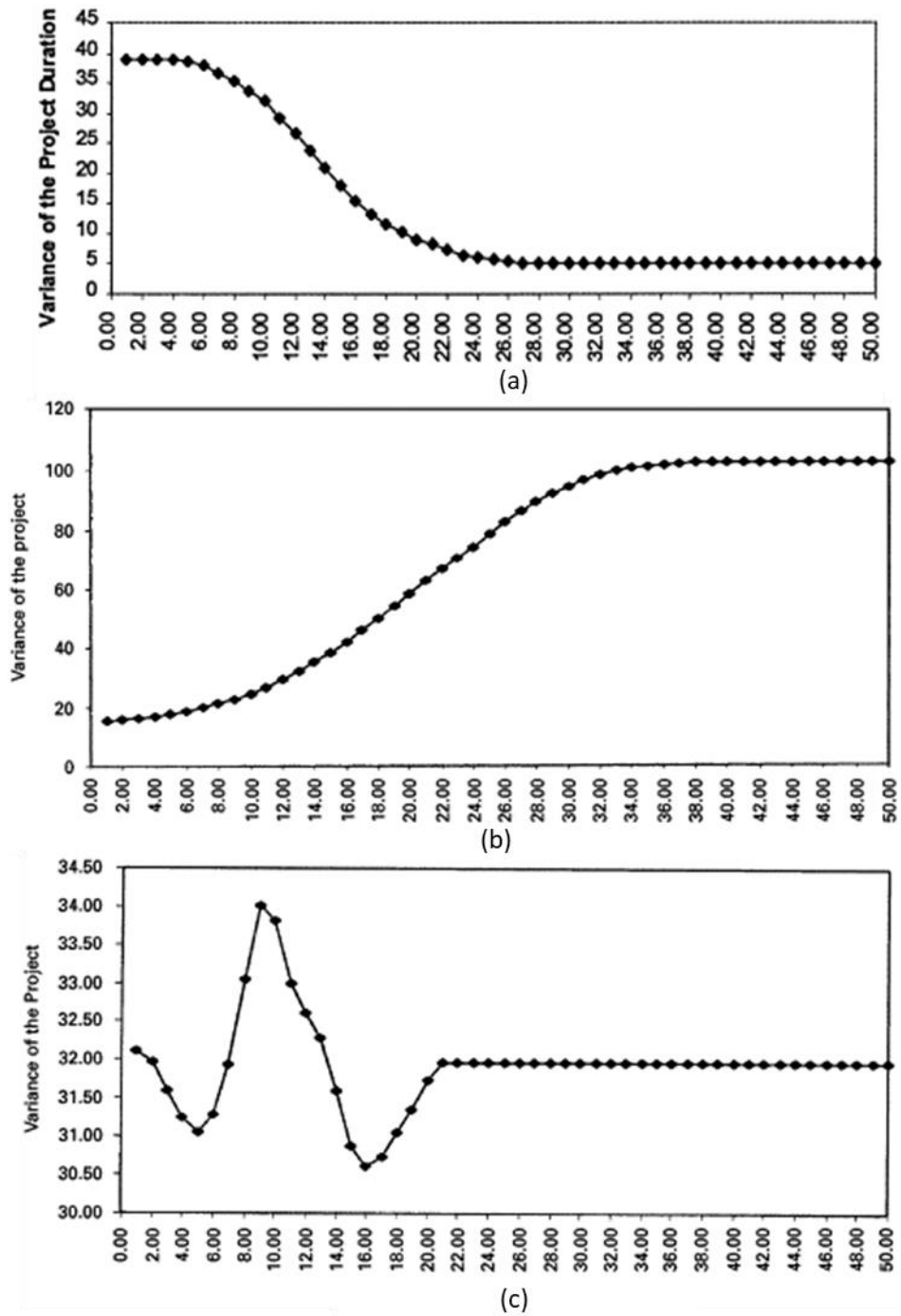

Elmalghraby, S. E., Fathi, Y., & Taner, M. R., 1998

On the other hand, by varying the mean of different activities while keeping their coefficient of variation constant, the following behaviors were found (see Figure 4.17):

- The impact on project duration variance remains unchanged when the average duration of an activity increases, up until it hits a specific threshold. Beyond this threshold, the project's duration variance begins to vary as the activity's average duration continues to increase. This variance follows a complex pattern within a certain range of the activity's average duration. However, once the average duration surpasses a certain level, the relationship between these two factors becomes more straightforward and linear.
- The variance of the project duration may increase (Figure 4.17.a) when the mean duration of the activity is increased, but, more interestingly, the variance of the project duration may decrease up to a point beyond which it increases (Figure 4.17.b) (Elmalghraby, S. E., Fathi, Y., & Taner, M. R., 1998).

Figure 4.17 Changes in project variance with changes in mean duration of activity
(constant activity coefficient of variation)

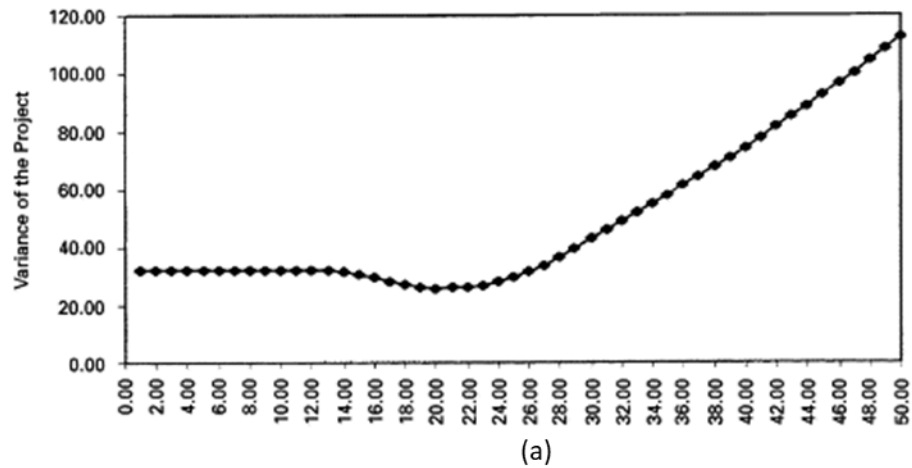

(a)

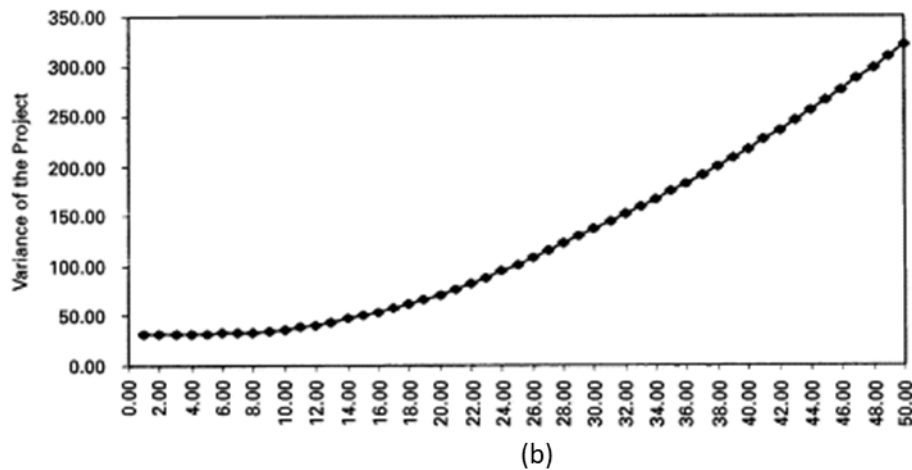

(b)

Elmalghraby, S. E., Fathi, Y., & Taner, M. R., 1998

The rationale behind the findings of Elmalghraby and Fathi (1998) is that the impact of changing an activity's average duration on the project's overall variance is markedly pronounced for activities that are components of the project's top five critical paths. For activities on these crucial paths, the project variance responds in a nonlinear way to changes in their mean duration. However, for activities situated on predominantly longer paths, changes in their mean duration do not significantly affect the project's overall variance (Elmalghraby, S. E., Fathi, Y., & Taner, M.

R., 1998). This indicates a nuanced relationship between individual activity durations and the broader project timeline, contingent on the criticality of the paths involved.

Overall, although the authors did not propose specific indexes to grasp these characteristics of project networks, their insights are extremely useful in reducing the number of activities to be included in the analysis of larger networks. According to their recommendations, managers should use the methodology put forth by Cho and Yum (1997) to determine the project's type of network in order to determine which paths are the most critical. Then, they should concentrate on the activities that fall along those critical paths, keeping in mind the aforementioned considerations regarding the sensitivity of project variance to activity mean duration.

4.2.6 Elmaghraby, S. E. (2000). On criticality and sensitivity in activity networks.

In 2000, Elmaghraby published an article that effectively summarized the three previously discussed studies. While not delving deeper into the topics, Elmaghraby's work is significant for its introduction of a taxonomy that aids in better understanding these analyses. This work builds on the foundation laid by Williams in 1993, who critiqued the traditional Criticality Index (CI) approach and initiated the concept of quantifying an activity's relative importance to project completion time. Indeed, the initial ambiguity surrounding the concept of an activity's importance in influencing project outcomes prompted researchers to systematically investigate the specific interdependencies analyzed above. The taxonomy is depicted in Figure 4.18:

Figure 4.18 Taxonomy of sensitivity problems

		Project	
		Mean	Variance
Activity	Mean	↗ ↘ G&P (1998)	EFT (1998)
	Variance		C&Y (1997)

Elmalghraby, S. E, 2000

As shown in Figure 4.18, the problem is fourfold. The 'mean–mean' section illustrates how altering the mean duration of an activity affects the project's mean duration. The directional arrows here show a direct and predictable correlation: increasing (or decreasing) the mean duration of an activity always results in a corresponding non-decrease (or non-increase) in the project's mean completion time. The 'variance–variance' section reflects the study by Cho and Yum (C&Y 1997) on how changes in an activity's duration variance impact the project's duration variance. The 'variance–mean' section, explored by Gutierrez and Paul (G&P 1998), examines the effects of variations in an activity's duration variance on the project's mean duration. Lastly, the 'mean–variance' section, analyzed by Elmalghraby, Fathi, and Taner (EFT 1998), focuses on the influence of changes in the mean duration of an activity on the variance of the project's duration.

4.2.7 - Vanhoucke, M. (2010). Using activity sensitivity and network topology information to Monitor Project Time Performance.

In 2010, Vanhoucke introduced another index following a recommendation from the PMI's PMBOK® Guide, which suggested that combining the standard deviations of activity duration and project duration with the Criticality Index would yield a more accurate estimate of the activity's significance in relation to the total project duration. The new metric is referred to as Schedule Sensitivity Index (SSI) and is computed generally as follows:

$$SSI_i = \sqrt{\frac{Var(d_i)}{Var(C_{max})}} \cdot CI_i \quad (63)$$

Or, for a simulation-based indicator:

$$SSI_i = CI_i \frac{s_{d_i}}{s_{C_{max}}} \quad (64)$$

Where CI_i , s_{d_i} , and $s_{C_{max}}$ can be computed by using formulas (48), (55), and (55) respectively with a simulation-based estimator. To give an example, by looking at Table 4.2 and 4.4, it is immediate to compute SSI for activity 2, resulting in $SSI_2 = 0.8 * (1100/6882.9)^{0.5} = 0.32$.

In his paper, Vanhoucke (2010) also compared the indexes discussed so far to understand which are, in general, the most reliable. Although his study presents some limitations, as it is based exclusively on simulated projects thus providing no project or sector case-specific conclusion, it marks an essential initial evaluation of these metrics. Overall, the research reveals that the schedule sensitivity index (SSI), along with the cruciality indexes $CRI(r)$ and $CRI(\rho)$, provides relatively better results than the criticality index (CI) and the sensitivity index (SI) (Vanhoucke, M., 2010).

4.2.8 Madadi, M., & Iranmanesh, H. (2012). A management oriented approach to reduce a project duration and its risk (variability).

While UIMA provides a new approach to sensitivity measures, it can be only used for projects in which their activities' distribution is symmetric, in addition, its implementation in large projects is too demanding if compared to traditional Monte Carlo simulations (Madadi, M., & Iranmanesh, H., 2012). In more recent years, Madadi (2012) introduced a new metric aiming at overcoming such UIMA limitations while integrating William's insights on uncertainty and impact on project completion time with considerations of the features of the project networks and the situation of activity in the project network.

The new index is called the Management Oriented Index (MOI) and involves the following criteria (Madadi, M., & Iranmanesh, H., 2012):

- Activities' variability (risk)
- Effect of activities on project mean duration
- Morphologic feature of the project network

For the first criterion, the activity variance $\text{Var}(d_i)$ is employed to gauge the risk associated with an activity. To consider the effect of activities on project mean duration, on the other hand, the authors suggest using the expected value of the activity's float. This approach is based on the understanding that as the probability of an activity's presence on the critical paths increases, the reduction in project completion time increases by decreasing the activity duration. (Madadi, M., & Iranmanesh, H., 2012) Finally, the distinction between different activities with different complexities or morphological features is considered through the definition of the Post_Density index:

$$\text{Post_Density}_i = \frac{\text{Total Successors}_i}{n} \quad (65)$$

where $\text{Total Successors}_i$ is the number of all activities, which are on the common path with activity i and are placed after it in the network and n is the number of activities in the project network (Madadi, M., & Iranmanesh, H., 2012). The purpose of this index is, therefore, to consider the topological importance an activity has on project duration by estimating the count of all potential paths that stem from it, based on the number of subsequent activities in the network. To understand the rationale behind this index, consider Figure 4.19.

Figure 4.19 Sub-networks of sample projects

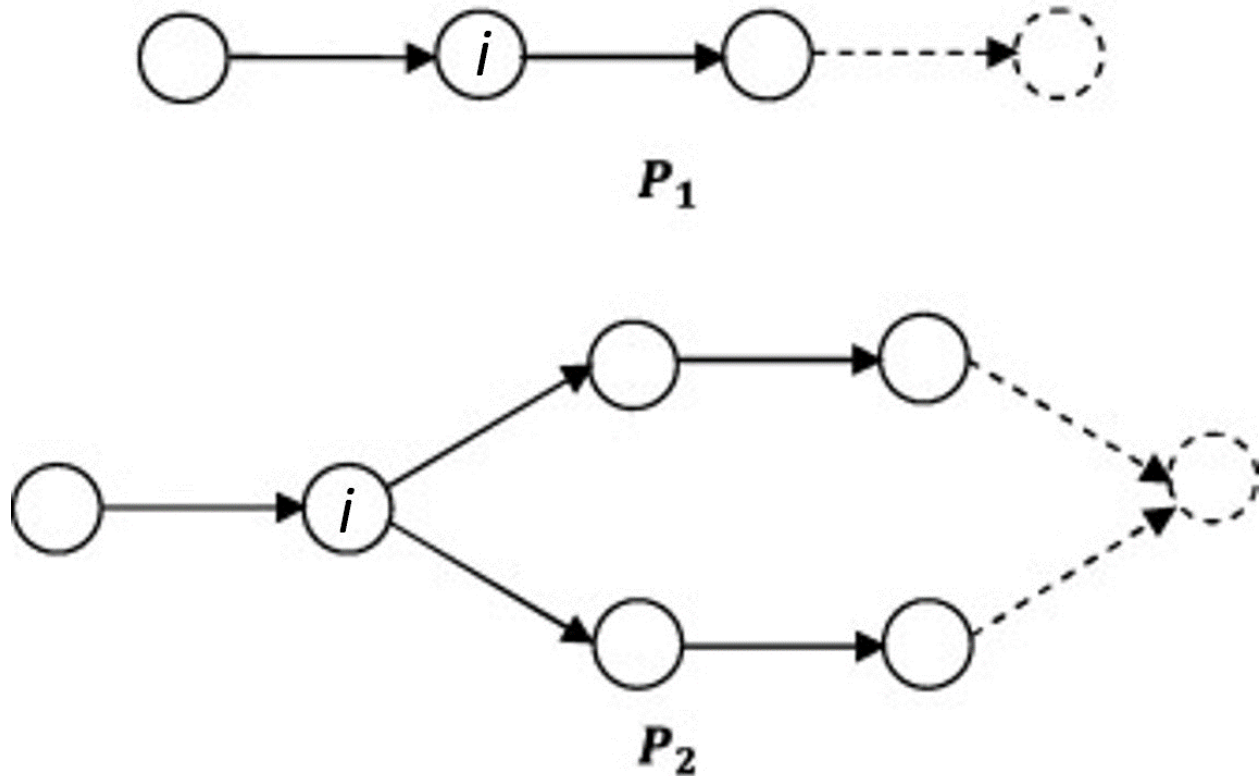

Madadi, M., & Iranmanesh, H., 2012

It is evident that the importance of activity i in the two sub-networks P_1 and P_2 is not the same. In fact, since the number of derived paths from activity i in P_1 ($=1$) is less than the number of derived paths in P_2 ($=2$), delaying activity i has less effect on P_1 completion time than P_2 completion time. The resulting formula for the MOI is the following:

$$MOI_i = \sqrt{\frac{Var(d_i)}{Max_i[Var(d_i)]}} \cdot \frac{1}{E(TF_i) - Post_Density_i + 1} \quad (66)$$

Where $Max_i[Var(d_i)]$ is the highest variance among the $Var(d_i)$ values of all activities. Formula (66) can then be computed as follows to obtain a simulation-based indicator:

$$MOI_i = \frac{s_{d_i}}{Max_i(S_{d_i})} \cdot \frac{1}{TF_i - Post_Density_i + 1} \quad (67)$$

Where S_{d_i} can be calculated through formula (55). To give an example, consider the values shown in Table 4.6, reporting S_{d_i} for each activity.

Table 4.6. Standard deviation calculations for all activities

	$(d_i^k - \bar{d}_i)^2$							
	1	2	3	4	5	6	7	8
Run 1	292.41	400	84.64	27.04	313.29	237.16	13.69	201.64
Run 2	0.81	81	14.44	17.64	28.09	43.56	32.49	46.24
Run 3	15.21	36	3.24	33.64	1.69	0.36	5.29	0.04
Run 4	15.21	49	23.04	14.44	5.29	31.36	5.29	148.84
Run 5	0.01	100	3.24	4.84	53.29	2.56	10.89	0.64
Run 6	47.61	144	10.24	0.04	59.29	0.36	0.49	0.04
Run 7	4.41	121	14.44	14.44	0.09	21.16	10.89	33.64
Run 8	82.81	16	14.44	0.04	13.69	5.76	13.69	3.24
Run 9	47.61	9	10.24	7.84	28.09	57.76	5.29	33.64
Run 10	34.81	144	17.64	17.64	53.29	88.36	0.09	33.64
s_{d_i}	7.75	11.06	4.66	3.91	7.86	7.37	3.30	7.47

By looking at the project network depicted in Figure 4.13, it is possible to establish that the Post_Density index for activity 2 is $Post_Density_2 = 2/8 = 0.25$. Therefore, the Management Oriented Index (MOI) of activity 2 is:

$$MOI_2 = (11.06/11.06) * [1/(1.1-0.25+1)] = 0.54$$

In their research, Madadi et al. (2012) also examined how the newly developed MOI stands up against existing metrics such as UIM, CRI, SI, and CI by testing on networks of varying sizes: a small network with 4 nodes and 5 activities, a medium-sized one with 10 nodes and 17 activities, and a large network consisting of 20 nodes and 38 activities. For each network, they evaluated the effectiveness of each index in managing the average duration and variability of the project. In the case of the small network, the proposed method results in more reduction in project mean duration

in comparison to the other four indices, whereas regarding project variability, the proposed method surpasses CI and SI and has similar performance to CRI and UIM (Madadi, M., & Iranmanesh, H., 2012). In the medium-sized network, on the other hand, all indexes perform effectively, with the MOI leading to slightly better results. Finally, in the large network, the proposed method surpasses other indices both in terms of reduction in the project mean and reduction in variance of the project duration (Madadi, M., & Iranmanesh, H., 2012). However, it is important to note that the comparison study conducted presents some limitations. One key limitation is the absence of the SSI in the evaluation, which does not allow for a full assessment of MOI's effectiveness. Another is that the comparison is made under static conditions on generic projects, which does not shed light on how the indices might perform during the actual execution of a project or indicate which indices are best suited for particular types of projects.

4.2.9 Ballesteros-Pérez, P., Cerezo-Narváez, A., Otero-Mateo, M., Pastor-Fernández, A., & Vanhoucke, M. (2019). Performance comparison of activity sensitivity metrics in schedule risk analysis.

In 2019, Ballesteros-Perez et al. proposed a refinement of the previous SSI and MOI metrics through the definitions of the Critical-Slack-Sensitivity index (CSS). In particular, the CSS constitutes an improvement of the SSI and MOI metrics by adding a third term considering the difference between activity i 's total float when all activity durations are stochastic ($E(TF_i)$) versus deterministic (TF'_i) (Ballesteros-Pérez, P., Cerezo-Narváez, A., Otero-Mateo, M., Pastor-Fernández, A., & Vanhoucke, M., 2019). The expression of the CSS is the following:

$$CSS_i = SSI_i \cdot \frac{E(TF_i) - TF'_i}{E(C_{max})} = CI_i \cdot \frac{E(TF_i) - TF'_i}{E(C_{max})} \cdot \sqrt{\frac{Var(d_i)}{Var(C_{max})}} \quad (68)$$

Which, based on the previous considerations, for a simulation-based index becomes:

$$CSS_i = CI_i \cdot \frac{\overline{TF}_i - TF'_i}{\bar{c}_{max}} \cdot \frac{s_{d_i}}{s_{C_{max}}} \quad (69)$$

As it is possible to observe, this newly introduced index comprises three components, each serving a distinct purpose. Firstly, the CI term helps to place greater emphasis on activities that are frequently critical. Secondly, the difference between the stochastic and deterministic slacks indirectly measures the average impact of the merge event bias in activity *i*, that is, how much the variability of all project activities allows activity *i* to shift (Ballesteros-Pérez, P., Cerezo-Narváez, A., Otero-Mateo, M., Pastor-Fernández, A., & Vanhoucke, M., 2019). More specifically, the merge event bias refers to how the interplay of activities within a project can introduce unpredictability in the timing of individual tasks, causing potential delays or shifts in the overall project schedule. In other words, it quantifies how the inherent variability in all project activities affects the timing and alignment of a specific activity, influencing its potential impact on the project's timeline. If this term is zero, this can be because either activity *i* is always critical or is never critical (Ballesteros-Pérez, P., Cerezo-Narváez, A., Otero-Mateo, M., Pastor-Fernández, A., & Vanhoucke, M., 2019). In the first case, both $E(TF_i)$ and TF'_i equal 0, whereas in the latter, $E(TF_i)$ equals TF'_i . However, in neither case will the activity contribute to minimizing the merge event bias, that is, to reducing the Project duration average (Ballesteros-Pérez, P., Cerezo-Narváez, A., Otero-Mateo, M., Pastor-Fernández, A., & Vanhoucke, M., 2019). This means that when this term is zero, the specific activity is relatively stable and does not pose a substantial risk to the project's schedule, so altering its timing or characteristics would not significantly impact the overall project timeline regardless of whether it is considered critical or non-critical. Finally, the third term reflects the proportion of project duration variability that can be controlled by the activity *i* itself (Ballesteros-Pérez, P., Cerezo-Narváez, A., Otero-Mateo, M., Pastor-Fernández, A., & Vanhoucke, M., 2019). An example is provided, once again, for activity 2 of the sample project. The only value missing

for the calculation is TF'_2 , which, however, is simply equal to 0 as activity 2 is critical in the deterministic network. Therefore, the Criticality-Slack-Sensitivity (CSS) index for activity 2 is:

$$CSS_2 = SSI_2 * (1.1-0)/99.1 = 0.32 * 0.01 = 0.003$$

All indexes discussed so far have been compared in practice by Ballesteros-Perez et al. (2019). The results show that when the metrics are calculated once off, i.e., at project inception, the top performing metric is the newly proposed Criticality-Slack-Sensitivity index (CSS) followed by the Cruciality Index with Kendall's tau (CRI(τ)) (Ballesteros-Pérez, P., Cerezo-Narváez, A., Otero-Mateo, M., Pastor-Fernández, A., & Vanhoucke, M., 2019). These results seem to contradict previous performance studies, such as the one conducted by Vanhoucke (2010) previously discussed. Nonetheless, according to Ballesteros-Perez et al. (2019), the effectiveness of these metrics significantly improves when they are updated repeatedly as the project progresses and durations of activities become more certain, despite the higher computational costs this method incurs. Under the iterative calculation assumption, the top performing metric remains the Schedule Sensitivity Index (SSI), closely followed by the CRI(r) and the CRI(ρ) (Ballesteros-Pérez, P., Cerezo-Narváez, A., Otero-Mateo, M., Pastor-Fernández, A., & Vanhoucke, M., 2019), aligning with Vanhoucke's earlier findings.

4.3 A mixed approach: Elshaer, R. (2013). Impact of sensitivity information on the prediction of Project's duration using earned schedule method.

Various research conducted by Vanhoucke and Vandervoode (2007, 2009) and Vanhoucke (2011) compare the top-down and bottom-up project control approaches to determine their respective strengths. All these studies conclude that a top-down project tracking approach is highly efficient for project networks with a serial activity structure, while a bottom-up approach performs

better in a parallel structured project network (Elshaer, R., 2013). That is, the efficiency of the bottom-up method increases with the degree of serial structure of the project network, while its effectiveness decreases for top-down methods, and vice versa. This outcome is expected since top-down project monitoring tends to fail in identifying the true reasons for delays when non-critical activities are responsible, leading to false warning signals. And this issue becomes more pronounced in serial networks, where such errors are likelier to occur. Based on these considerations, Elshaer (2013) devised a hybrid model that incorporates both top-down and bottom-up elements to enhance the predictive accuracy of project completion times. Specifically, Elshaer (2013) investigated the impact of activities' sensitivity information on the earned value calculations on the project time performance indicator of Earned Schedule Methodology (ESM), with the aim to improve the forecasting accuracy of ESM by decreasing or even removing the false warning effects caused by the non-critical activities. In doing so, the influence of activity-based sensitivity measures on the forecasting accuracy of ESM is examined in three levels: 1 — overall forecasting accuracy, 2 — during project progress, and 3 — at a certain project network structure (Elshaer, R., 2013).

The proposed methodology to fulfill this aim is to merge the sensitivity information into the earned value calculations by introducing a weighing factor α_i into Earned Value (EV) and Planned Value (PV) computations. Specifically, EV becomes:

$$EV_{\alpha} = \sum_i \alpha_i \cdot EV_{i,AT} \quad (70)$$

Analogously, the PV is computed as:

$$PV_{\alpha,t} = \sum_i \alpha_i \cdot PV_{i,t} \quad (71)$$

Where $EV_{i,AT}$ is the earned value of activity i at actual time AT , while $PV_{i,t}$ is the planned value of activity i at time instance t (Elshaer, R., 2013). The earned schedule, ES_{α} , and schedule performance index, $SPI(t)$, based on the weighting factor α can then be easily calculated. On the other hand, α_i represents the weighting factor for each activity i . In the model studied by Elshaer, $\alpha_i \in \{1, CI_i, SI_i, SSI_i, CRI_i(r), CRI_i(\rho), CRI_i(\tau)\}$, where $\alpha = 1$ means that the project duration estimation is based on no distinction among activities and all the activities have an equal weight in the total earned value calculations (Elshaer, R., 2013). The underlying idea is to test on several simulations the impact of the aforementioned sensitivity measures on the forecasting accuracy of ESM, with the ultimate goal to discern whether these refinements enhance the methodology and, if so, to determine which sensitivity measure is most effective.

The findings of the research can be concluded in the following lines: through all the three levels analyzed ESM_{CI} , i.e., ESM computed with $\alpha_i=CI_i$, is considered the most reliable metric in forecasting a project's final duration, where ESM_{CI} outperforms ESM in case of false warning coming from non-critical activities and performs as well as ESM in case of normal conditions (Elshaer, R., 2013). Therefore, it is recommended that practitioners use the ESM_{CI} and the traditional ESM at the same time in predicting a project's final duration. By doing so, any false warning due to delays and/or ahead in the non-critical activities will be eliminated and detected at the cost account level without drilling down to lower work breakdown structure levels (Elshaer, R., 2013). These findings may appear quite surprising, as previous studies on sensitivity metrics claimed that the traditional CI was one of the least reliable sensitivity measures. However, this improvement can be explained by the CI's specific focus on the probability of an activity being on the critical path. Traditional Earned Schedule Management (ESM) and top-down approaches typically struggle to account for the impact of non-critical activities. Since the CI directly assesses

the potential criticality of activities, it naturally addresses this blind spot, while other sensitivity measures, which include the assessment of the variance contribution of activities to overall project variability, do not directly target this issue.

4.4 Discussion

Overall, all these approaches enhance EVM in some way, but the question of which one to use and in what circumstances remains unanswered, although a partial solution is given. Indeed, as concluded in the studies by Vanhoucke and Vandervoode (2007, 2009) and Vanhoucke (2011), comparing the top-down and bottom-up project control approaches to determine their respective strengths, a top-down project tracking approach is highly efficient for project networks with a serial activity structure, while a bottom-up approach performs better in a parallel structured project network. Moreover, factors like size, complexity, and uncertainty may direct managers to an approach that better answers their needs. To give an example, a large, complex project, characterized by high uncertainty and many activities in parallel would probably require a bottom-up approach. As reported by Ballesteros-Perez et al. (2019a), if the company prefers sustaining a lower computational effort thus calculating sensitivity indexes once at the project inception, the best choice would be using the Criticality-Slack-Sensitivity (CSS) index, whereas in the case it would be willing to iterate the calculations as the project progresses, the advisable choice would be using the Schedule Sensitivity Index (SSI). Despite not being featured in Ballesteros-Perez et al.'s (2019a) comparative analysis, the studies by Cho and Yum (1997), Gutierrez and Paul (1998), and Elmalghraby et al. (1998) present limited practicality in application. Indeed, while these methodologies enable activity selection based on how changes in the mean or variance of an activity can impact the overall project time distribution, they are significantly more complex to compute than other methods, making their practical use overly challenging. Conversely, the same

project but presenting a predominantly longer path could be carried out by using a top-down approach that accounts for uncertainty. If the primary concern is the variability in the total duration of the project, methods like the Monte Carlo simulation or the ES min-max methodology could provide a dependable range of outcomes. Additionally, when using ES min-max, the company may leverage its flexibility and pair it with the Earned Duration Methodology (EDM) to reduce the number of false alarms other deterministic approaches typically generate. On the other hand, in situations where a firm is concerned with uncertainty throughout project execution and desires to understand whether variations from planned values fall within the regular variability of the project or are due to unforeseen factors, the choice narrows down to methods like Fuzzy numbers, SCoI, and Triad approaches. Among these, the Triad method stands out for its effectiveness, as validated by the research of Acebes et al. (2015). Finally, serial projects with low levels of uncertainty could be easily monitored through the Earned Schedule (ES) or Earned Duration Methodology (EDM). In this case, managers should consider their strengths and weaknesses. As found by Ballesteros-Pérez et al. (2019b), EDM excels in schedule monitoring and early warning signals, while ES is superior for estimating total project duration. However, each has its drawbacks. On one hand, even though ES measures time performance in time units, it still relies on traditional EVM metrics, thus not overcoming entirely the assumption of a linear correlation between cost and time factors in projects. On the other hand, EDM introduces a new framework to monitor schedule progress that is completely untied from cost measures. Although this might be advantageous for schedule tracking, with this method managers are required to duplicate their computational effort and employ different models to track cost and schedule. Moreover, discerning the cost and time dimensions entirely may hinder the ability to grasp correlations among them when they are present.

However, the categorization of project networks as either serial or parallel is somewhat simplistic. In scenarios where parallelism or seriality is clearly defined, the main challenge lies in selecting the most suitable approach from the various options identified. However, many projects present hybrid or intermediate characteristics, complicating this decision. In such instances, logically, a combination of top-down and bottom-up approaches seems appropriate. Yet, the specifics of which methods to combine, how they interact, their respective strengths and weaknesses, and other details remain largely unexplored. While one methodology that integrates both top-down and bottom-up approaches has been examined, it does not specifically address the nuances of project network topology, size, complexity, or industry application. Consequently, there is a pressing need for comprehensive research to identify tailored solutions for each unique scenario or, ideally, develop a singular, straightforward, and effective methodology that addresses all the aforementioned challenges. Initial research should focus on comparing the various methodologies in diverse project conditions, encompassing aspects like network structure, project size, uncertainty, and industry sectors. This would help pinpoint the specific advantages and limitations of each approach. Following these insights, the next steps would involve either creating a detailed guide for selecting the most appropriate technique for a given project scenario or developing new methodologies that are specifically tailored to certain situations. Alternatively, the goal could be to devise a universal methodology that effectively addresses all these concerns. It is important to note that this development should not be confined to academic research alone. Indeed, a shift in practice and policy is essential to facilitate this advancement. Wider adoption of these methodologies in the field of project management would allow managers to become more familiar with them, recognize their benefits, and encourage organizations to support further research. Additionally, increased practical application of these methods would generate more data, aiding in

the evaluation of their effectiveness and applicability. This, in turn, would help answer many of the unresolved questions in both practical and research contexts. However, transitioning from traditional project management approaches might face resistance. Therefore, updating project management standards and certifications to include these methodologies is crucial. Such policy changes, coupled with training a new generation of project managers open to innovative approaches, are essential steps towards embracing less traditional EVM methods.

Lastly, it is important to note that this review, while comprehensive, is not without its limitations in the evidence included. Primarily, the reliance on published, peer-reviewed articles may have inadvertently excluded valuable insights from grey literature or industry-specific reports, potentially limiting the breadth and diversity of perspectives. This is particularly relevant given our earlier discussion on the selection of project management metrics, which can vary significantly depending on project size, complexity, and structure. The exclusion of non-academic sources could mean overlooking practical insights and real-world applications of these methodologies, especially in diverse project environments that may not be adequately represented in academic research. Additionally, despite efforts to mitigate biases such as selection bias, the inherent nature of literature reviews may still lead to an over-representation of certain viewpoints or methodologies. This could skew the review's conclusions, favoring more established or widely recognized approaches over emerging or unconventional ones. This aspect is crucial when considering the adaptability of project management methodologies in different project settings, as the review might have emphasized certain methodologies that are more prevalent in academic literature but less so in practical, varied project environments. The impact of these limitations on the generalizability and applicability of the review's findings should be acknowledged, suggesting a need for future research to include a wider range of sources for a more holistic understanding of the subject.

Finally, the absence of a planned synthesis and sensitivity analysis limits the depth of understanding regarding the comparative effectiveness of different project management methodologies. Engaging in such analyses could provide valuable insights into how different methodologies perform under various project conditions, complementing the findings of this review. Furthermore, the review's focus on synthesizing existing literature without applying these methodologies to a common dataset means that the findings are more interpretative than empirical. This could affect the robustness of the conclusions drawn, as they are based on secondary analysis rather than primary data.

Conclusion

This paper has provided an overview of the main methodologies developed over the years to monitor and control schedule performance in Project Management (PM). All the studies presented include techniques that address one or more of the limitations that the most popular tracking tool in PM presents, namely, Earned Value Management (EVM). These studies are categorized in two main tracking approaches: top-down and bottom-up project control. While the former adopts a broad perspective, utilizing overarching performance metrics like those in EVM, and then zeroes in on specific activities to address discrepancies, the latter focuses on individual activities from the outset, prioritizing activities based on their sensitivity or potential impact on the project.

In top-down approaches, both deterministic and stochastic methods are included. Among the former, the Earned Schedule (ES) and Earned Duration Management (EDM), introduced by Lipke (2003) and Khamooshi and Golafshani (2014) stand out, with S being superior in estimating

total project duration and EDM in signaling discrepancies during execution. However, an enhancement to the ES method was recently proposed by Ballesteros-Pérez et al. (2019b). This improved version, referred to as ES min-max, surpasses the conventional ES in forecasting the time of project completion and offers greater versatility, as it can be integrated with a variety of other approaches. On the other hand, Triad methodology by Acebes et al. (2014) represents the pinnacle of top-down stochastic approaches, effectively integrating EVM with risk and uncertainty. Bottom-up approaches, meanwhile, encompass a set of sensitivity metrics designed to numerically evaluate which activities are crucial for the timely completion of a project. Within this category, two methods stand out for their effectiveness. The Criticality-Slack-Sensitivity (CSS) index, introduced by Ballesteros-Pérez et al. (2019a), proves to be the most effective when metrics are calculated once at the start of the project. On the other hand, for a more dynamic approach where metrics are reassessed regularly during the project's lifecycle, the Schedule Sensitivity Index (SSI) by Vanhoucke (2010) is the preferred method.

Drawing from these findings and the research conducted by Vanhoucke and Vandervoode (2007, 2009) and Vanhoucke (2011), which suggests that top-down approaches are more effective in serial project networks and bottom-up approaches in parallel ones, several conclusions have been formulated. These insights are valuable for project managers in determining the most appropriate methodology for their particular projects, considering the network structure and complexity involved. However, it's important to note that these insights are derived from secondary sources and have not been empirically validated. Future research should therefore concentrate on more rigorously evaluating the effectiveness of each discussed methodology across different scenarios, taking into account factors such as the size and complexity of the project, the degree of uncertainty involved, and the specific industry sector. Moreover, when the serial or parallel nature

of a project's activities is unclear, it's not evident whether top-down or bottom-up methods are preferable. Indeed, although a methodology introduced by Ballesteros-Pérez et al. (2019b) that combines top-down and bottom-up approaches has been discussed, it lacks specificity regarding project type and sector. Therefore, future research should focus on assessing the effectiveness of each methodology in diverse scenarios to provide managers with a clearer understanding of the most suitable approach for their projects. Furthermore, the development of new, tailored methodologies and numerical tools to determine the best approach for specific cases should be pursued. Nevertheless, efforts in research should be accompanied by a shift in both practice and policy. Indeed, integrating these methodologies into recognized best practices and certifications is essential for encouraging their use in everyday professional activities. In turn, this adoption will enhance their recognition and generate valuable real-world data, thereby fostering the continuous development and refinement of new approaches in both theoretical and practical realms.

References

- Acebes, F., Pajares, J., Galán, J. M., & López-Paredes, A. (2014). A new approach for project control under uncertainty. going back to the basics. *International Journal of Project Management*, 32(3), 423–434.
- Acebes, F., Pajares, J., Galán, J. M., & López-Paredes, A. (2015). A Project Monitoring and control system using EVM and Monte Carlo Simulation. *Lecture Notes in Management and Industrial Engineering*, 31–40.
- Acebes, F., Pereda, M., Poza, D., Pajares, J., & Galán, J. M. (2015). Stochastic earned value analysis using Monte Carlo Simulation and Statistical Learning Techniques. *International Journal of Project Management*, 33(7), 1597–1609.
- Anbari, F. T. (2003). Earned value project management method and extensions. *Project Management Journal*, 34(4), 12–23.
- Anbari, F. T. (2011). *Advances in earned schedule and earned value management*. Paper presented at PMI® Global Congress 2011—North America, Dallas, TX. Newtown Square, PA: Project Management Institute.
- Bagherpour, M., Zareei, A., Noori, S., & Heydari, M. (2009). Designing a control mechanism using earned value analysis: An application to production environment. *The International Journal of Advanced Manufacturing Technology*, 49(5–8), 419–429.
- Ballesteros-Pérez, P., Cerezo-Narváez, A., Otero-Mateo, M., Pastor-Fernández, A., & Vanhoucke, M. (2019a). Performance comparison of activity sensitivity metrics in schedule risk analysis. *Automation in Construction*, 106, 102906.
- Ballesteros-Pérez, P., Sanz-Ablanedo, E., Mora-Melià, D., González-Cruz, M. C., Fuentes-Bargues, J. L., & Pellicer, E. (2019b). Earned schedule Min-Max: Two new EVM metrics for monitoring and controlling projects. *Automation in Construction*, 103, 279–290.
- Borges, W. F., & Mário, P. do. (2017). Five project-duration control methods in time units: Case study of a linearly distributed planned value. *Journal of Construction Engineering and Management*, 143(6).
- Carayannis, E. G., Kwak, Y. H., & Anbari, F. T. (2003). Chapter 2. Brief History of Project Management. In *The Story of Managing Projects*. essay, Quorum Books.
- Cho, J. G., & Yum, B. J. (1997). An uncertainty importance measure of activities in Pert Networks. *International Journal of Production Research*, 35(10), 2737–2758.
- Datz, M. A. (1977). What is good project management? *Project Management Quarterly*, 8(1), 13–17.

- De Marco, A. (2018). Project Monitoring and Control. In *Project Management for Facility Constructions* (pp. 123–145). essay, Springer.
- Durach, C. F., Kembro, J., & Wieland, A. (2017). A new paradigm for systematic literature reviews. *Journal of Supply Chain Management*, 53(4), 67–85.
- Elmaghraby, S. E. (2000). On criticality and sensitivity in activity networks. *European Journal of Operational Research*, 127(2), 220–238.
- Elmalghraby, S. E., Fathi, Y., & Taner, M. R. (1998). On the sensitivity of project variability to activity mean duration. *International Journal of Production Economics*.
- Elshaer, R. (2013). Impact of sensitivity information on the prediction of Project's duration using earned schedule method. *International Journal of Project Management*, 31(4), 579–
- Gutierrez, G., & Paul, A. (1998). Analysis of the effects of uncertainty, risk-pooling, and subcontracting mechanisms on project performance. *Operations Research*, 48(6), 927–938.
- Gutterman, A. S. (2023, July). *Project Management*. Researchgate.
- Heagney, J. (2016). *Fundamentals of Project Management* (5th ed.). Amacom.
- Hillson, D. (2014). *How risky is your project — And what are you doing about it?* Paper presented at PMI® Global Congress 2014—North America, Phoenix, AZ. Newtown Square, PA: Project Management Institute
- Jacob, D. (2003). Forecasting project schedule completion with earned value metrics. *The Measurable News*, 1(11), 7-9.
- Jones, C. (2008). *Moving from the WBS to a critical path schedule*. Paper presented at PMI® Global Congress 2008—North America, Denver, CO. Newtown Square, PA: Project Management Institute.
- Khamooshi, H., & Golafshani, H. (2014). EDM: Earned duration management, a new approach to schedule performance management and measurement. *International Journal of Project Management*, 32(6), 1019–1041.
- Kramer, S. W. & Jenkins, J. L. (2006). *Understanding the basics of CPM calculations: what is scheduling software really telling you?* Paper presented at PMI® Global Congress 2006—EMEA, Madrid, Spain. Newtown Square, PA: Project Management Institute.
- Lipke, W. (2003, January). *Schedule is different*. Reserchgate.
- Madadi, M., & Iranmanesh, H. (2012). A management oriented approach to reduce a project duration and its risk (variability). *European Journal of Operational Research*, 219(3), 751–761.

- Mayo-Alvarez, L., Alvarez-Risco, A., Del-Aguila-Arcentales, S., Sekar, M. C., & Yañez, J. A. (2022). A systematic review of earned value management methods for monitoring and control of Project Schedule Performance: An AHP approach. *Sustainability*, 14(22), 15259.
- Nizam, A., & Elshannaway, A. (2019). Review of Earned Value Management (EVM) methodology, its limitations, and applicable extensions. *The Journal of Management and Engineering Integration* Vol. 12, No. 1.
- Pajares, J., & López-Paredes, A. (2011). An extension of the EVM analysis for Project Monitoring: The cost control index and the schedule control index. *International Journal of Project Management*, 29(5), 615–621.
- Project Management Institute. (2021). *A Guide to the Project Management Body of Knowledge. PMBOK® Guide - 7th edition.*
- Reichel, C. W. (2006). *Earned value management systems (EVMS): "you too can do earned value management"* Paper presented at PMI® Global Congress 2006—North America, Seattle, WA. Newtown Square, PA: Project Management Institute.
- Scott, W. J. (2012). *TCPI: the tower of power.* Paper presented at PMI® Global Congress 2012—North America, Vancouver, British Columbia, Canada. Newtown Square, PA: Project Management Institute.
- Seymour, T., & Hussein, S. (2014). The History of Project Management. *International Journal of Management & Information Systems*, 18, 233–238.
- Song, J., Martens, A., & Vanhoucke, M. (2022). Using earned value management and schedule risk analysis with resource constraints for Project Control. *European Journal of Operational Research*, 297(2), 451–466.
- Stone, C. (2023). *Challenges and opportunities of completing successful projects using earned value management.* SCIRP.
- Thakkar, J. J. (2022). Project Monitoring and Control. In *Project Management* (pp. 279–298). essay, Springer.
- The Standard for Earned Value Management (2019). PMI.
- Tzaveas, T., Katsavounis, S., Kalfakakou, G. (2010). *Analysis of Project Performance of a Real Case Study and Assessment of Earned Value and Earned Schedule Techniques for the Prediction of Project Completion Date.* Proceedings of IPMA Conference, May 2010 - Crete, Greece. 752-759.
- Van Slyke, R. M. (1963). Monte Carlo Methods and the PERT Problem. *Operations Research*, 11(5), 839–860.

- Vanhoucke, M, & Vandevorde, S. (2007). A simulation and evaluation of Earned Value Metrics to forecast the project duration. *Journal of the Operational Research Society*, 58(10), 1361–1374.
- Vanhoucke, M., & Vandevorde, S. (2009). Forecasting a Project's Duration under Various Topological Structures. *The Measurable News*, (1), 26–29.
- Vanhoucke, M. (2010). Using activity sensitivity and network topology information to Monitor Project Time Performance. *Omega*, 38(5), 359–370.
- Vanhoucke, M. (2011). On the dynamic use of Project Performance and schedule risk information during project tracking. *Omega*, 39(4), 416–426.
- Vanhoucke, M. (2016). Schedule Risk Analysis. In: *Integrated Project Management Sourcebook*, 111-154. Springer, Cham.
- Weaver, P. (2022). The Origins and History of Earned Value Management. *PM World Journal*, Vol. XI, Issue VIII.
- Williams, T. M. (1993). Criticality in Stochastic Networks. *The Journal of the Operational Research Society*, 43(4), 353–357.