



**Politecnico  
di Torino**

**POLITECNICO DI TORINO**

**MASTER OF SCIENCE IN COMMUNICATIONS AND COMPUTER**

**NETWORKS ENGINEERING**

**MASTER'S THESIS TITLE**

**Smart Monitoring Device for biomedical applications.**

**Academic Advisor:**

**Candidate:**

Supervisor: Prof.LADISLAU MATEKOVITS

Asadullah Javed(S289508)

Co-Supervisor: Prof.ILDIKO PETER

OCTOBER 23

## **Acknowledgement**

I express my sincere gratitude to **Prof. LADISLAU MATEKOVITS**, my supervisor and co-supervisor **ILDIKO PETER** , for their invaluable guidance and support throughout the completion of this thesis. Their mentorship has been instrumental in shaping my work.

I am deeply appreciative and indebted to my family, whose unwavering support both physically and emotionally has been incomparable. Their encouragement played a vital role in helping me achieve my goals.

In addition, I want to thank my friends for their encouragement. They supported me through good times and bad, giving me the bravery and fortitude to face problems.

Without the collective support and encouragement of my supervisors, family, and friends, this achievement would not have been possible

## Table of Contents

<b>ABSTRACT .....</b>	<b>6</b>
<b>CHAPTER #1: INTRODUCTION: .....</b>	<b>7</b>
<b>1.1 BACKGROUND: .....</b>	<b>7</b>
<b>1.2 STATISTICAL ANALYSIS OF HEART AND BLOOD VESSEL CONDITIONS.....</b>	<b>9</b>
<b>1.3 RESPIRATORY DISEASE.....</b>	<b>10</b>
<b>1.4: CONGENITAL HEART DEFECTS.....</b>	<b>11</b>
<b>CHAPTER # 2: LITERATURE REVIEW AND MAINLINE.....</b>	<b>12</b>
<b>2.1 HEALTH MONITORING SYSTEM: .....</b>	<b>12</b>
<i>2.1.1 Wireless technology implemented on Health Monitoring system: .....</i>	<i>12</i>
<i>2.1.2 Wearable technology implemented on Health Monitoring system: .....</i>	<i>12</i>
<i>2.1.3 Commercially available technology: .....</i>	<i>13</i>
<b>2.2 BRIEFING ON BIOSENSORS: .....</b>	<b>13</b>
<b>2.3 ATTRIBUTES OF BIOLOGICAL SENSORS:.....</b>	<b>14</b>
<i>2.3.1 Dependability: .....</i>	<i>14</i>
<i>2.3.2 Consistent Linearity: .....</i>	<i>14</i>
<i>2.3.3 Sensitivity: .....</i>	<i>15</i>
<i>2.3.4 Stability: .....</i>	<i>15</i>
<i>2.3.5 Specificity: .....</i>	<i>16</i>
<b>2.4 BASIC IDEA: .....</b>	<b>16</b>
<b>2.5 SENSING DEVICES AND THEIR CATAGORIES:.....</b>	<b>17</b>
<i>2.5.1 Ph sensor: .....</i>	<i>18</i>
<i>2.5.2 Oxygen saturation (SpO2) and pulse oximetry: .....</i>	<i>18</i>
<i>2.5.3 Thermal Sensor: .....</i>	<i>19</i>
<b>2.6 SELECTIVITY AND SENSITIVITY OF BIOSENSORS:.....</b>	<b>19</b>
<i>2.6.1 Precision: .....</i>	<i>19</i>
<i>2.6.2 Sensing Time:.....</i>	<i>20</i>
<i>2.6.3 Detection Threshold: .....</i>	<i>20</i>
<i>2.6.4 Peculiarity: .....</i>	<i>20</i>
<b>2.7 NANOMATERIALS AND BIOLOGICAL SENSING:.....</b>	<b>20</b>
<b>2.8 NANOMATERIALS FRAMEWORK- KEY CONSTITUENTS IN BIO-ANALYTICAL DEVICES: .....</b>	<b>21</b>
<i>2.8.1 Gold Nanomaterials: .....</i>	<i>21</i>
<i>2.8.2 Quantum Nanoparticles: .....</i>	<i>22</i>
<i>2.8.3 Carbonaceous Nanoparticles: .....</i>	<i>22</i>
<b>2.9 BIO-MONITORING SYSTEM AND CYBER PROTECTION: .....</b>	<b>22</b>

2.9.1 Purposes:.....	23
2.9.2 Classes: .....	24
2.9.3 SubClasses:.....	24
2.9.4 Information Repository: .....	24
<b>2.10 IMPLICATIONS OF BIOSENSORS:.....</b>	<b>24</b>
<b>CHAPTER # 3: MODELLING AND SIMULATION.....</b>	<b>26</b>
<b>3.1: TEST ENVIRONMENT: .....</b>	<b>26</b>
<b>3.2: HEARTBEAT SENSOR. ....</b>	<b>26</b>
3.2.1: LM35.....	28
3.2.2: Display segment.....	29
<b>3.3: MICROCONTROLLER.....</b>	<b>29</b>
3.3.1.Details about ATmega328P:.....	30
3.3.2.Working Principle:.....	30
<b>3.4 ESP8266-01 MODULE:.....</b>	<b>31</b>
3.4.1 Details of ESP8266-01. ....	31
3.4.2 Working Principle. ....	32
<b>3.5: SIMULATION AND RESULTS.....</b>	<b>32</b>
<b>3.6 EXPERIMENTATION:.....</b>	<b>35</b>
3.6.1 Ph Sensor: .....	35
3.6.2 Basics: .....	36
3.6.3 Product description.....	36
3.6.4 GFET ADUCM355 BOARD. ....	38
<b>3.7 PROCEDURE. ....</b>	<b>39</b>
<b>CHAPTER# 4.....</b>	<b>40</b>
<b>CONCLUSION: .....</b>	<b>40</b>
<b>BIBLIOGRAPHY .....</b>	<b>42</b>

## **LIST OF FIGURES.**

FIGURE 1: 1.1.1.BIOSENSORS AND CHEMICAL SENSORS FOR HUMAN INFORMATION.....	8
FIGURE 2:1.2.1.MORTALITY RATES FROM CARDIO VASCULAR DISEASE.....	10
FIGURE 3:2.4.1.TRANSMITTER SIDE .....	16
FIGURE 4:2.4.2.RECEIVER SIDE.....	16
FIGURE 5:2.5.1.1.PH SENSOR.....	18
FIGURE 6:2.5.2.1.MAX32664D.....	18
FIGURE 7:2.5.3.1.LM35.....	19
FIGURE 8:3.2.1.SIMPLE HEART BEAT SENSOR.....	27
FIGURE 9:3.2.2.PIN CONFIGURATIONS.....	27
FIGURE 10:3.2.1.1.LM35CONNECTED WITH MICROCONTROLLER.....	28
FIGURE 11:3.2.2.1.DISPLAY SEGMENT.....	29
FIGURE 12:3.3.1.MICROCONTROLLER ATMEGA328P.....	29
FIGURE 13:3.4.1.ESP8266-ESP-01 MODULE FOR WIFI CONNECTIVITY.....	31
FIGURE 14:3.5.1.SMART PATIENT HEALTH MONITORING SYSTEM   PROTEUS SIMULATION .....	33
FIGURE 15:3.5.2.LCD UNIT.....	33
FIGURE 16:3.5.3.DIGITAL OSCILLOSCOPE .....	34
FIGURE 17:3.5.5.HEART RATE GRAPH .....	34
FIGURE 18:3.5.4.TEMPERATURE GRAPH .....	34
FIGURE 19:3.6.1.1.HOW ELECTRODES WORK.....	35
FIGURE 21:3.6.3.1.MECHANICAL DRAWING .....	36
FIGURE 20:3.6.3.2.SPECIFICATION OF PH SENSOR.....	36
FIGURE 22:3.6.3.3.SIGNAL MILIVOLTS VS PH [20].....	37
FIGURE 23:3.6.3.4.27 MINUTES TESTING RESULTS GRAPH [20] .....	37
FIGURE 24:3.6.3.5.PH SENSOR AFTER FEW DAYS STORAGE AT ROOM TEMPERATURE [20].....	38
FIGURE 25:3.6.4.1.GFET MODULE.....	38
FIGURE 26:3.7.1.RESULTS OF PH VALUES.....	39

## **Abstract**

World is moving towards intelligence and automation in every field including pharmaceuticals. Wellbeing care systems as well as further surgeries operations are experiencing within the exploratory stages. These biomedical inserts are in testing stage with coordinate contact of skin to think about inconsistencies of any kind. Biomedical inserts field is revolutionizing the restorative science. Tests are being carried from a decade to adjust these innovation as before long as conceivable.

This proposition's main goal is to consider a real-time understanding observation framework. Our main goal is to think about biomedical sensors that can measure our vital signs, provide emergency alerts, and administer medications when they are needed. I started by thinking about the crucial variables that must be tracked in the patients, such blood oxygen, glucose level, and temperature. Then I looked at several sensors that may be used and a simulation of such a system that is described in the Proteus documentation. Understanding how these sensors function and how prepared they are to coordinate different types of sensors with one another is the main goal of this simulation. In addition, as we continue on this path, we also reach out to emerging and unique businesses in order to deeply examine and create a few test beds as the cornerstone of an acceptable strategy.

The idea of telemedicine and telemonitoring of persistent at-home patients to minimize physical contact as much as possible is supported by the recent COVID-19 event. Furthermore, the use of biosensors isn't only limited to the therapeutic sector anymore; it has expanded to include our daily routines as well.

## **Chapter #1: Introduction:**

### **1.1 Background:**

The first biosensors were created in 1906 when M. Cremer [1] showed that the electric potential that develops between fluid components that are on opposing sides of a glass membrane is proportional to the concentration of an acid in a liquid. However, Sren Peder Lauritz Srensen didn't present the idea of pH (hydrogen ion concentration) until 1909, and W.S. Hughes didn't develop an electrode for pH measurements until 1922 [2]. Griffin and Nelson [3] were the first to show that the enzyme invertase could be immobilized on aluminum hydroxide and charcoal between 1909 and 1922. Leland C. Clark Jr. created the first "true" biosensor for oxygen sensing in 1956. He is referred to as the "father of biosensors," and he is credited with creating the oxygen electrode.: 'Clark electrode' [4]

Microelectromechanical systems (MEMS) technology-based biosensors and chemical sensors have been created to replace pricey and difficult analytical instruments used in healthcare with small, widely-accepted sensors designed for healthcare applications [5]. It is crucial for the advancement of healthcare and medical monitoring to integrate biosensors into the internet-of-things (IoT) system in order to enhance quality of life (QoL). Devices that use optical, piezoelectric, and electrochemical transducers to detect analytes have advanced dramatically during the last 50 years [6]. Due to their great performance, mobility, simplicity, and cheap cost, electrochemical sensors are starting to be employed in a range of analytical, medical diagnostic, and screening applications. Along with advancements in biosensors, metabolites and electrolytes may now be detected using portable analyzers.

However, since blood must be drawn in order to take the readings, the majority of these traditional sensors are intrusive. As a result, the patient is under a lot of stress and has a significant risk of

infection and other issues. For patients who are old or babies, this is extremely difficult. Furthermore, continual measurement in biometry is crucial in many different disciplines. For instance, frequent blood glucose monitoring is required for the best management of diabetes [7]. Real-time detection of viruses and pathogens in the body may also signal the beginning of a disease. The effects of medications should also be regularly observed. In the aforementioned scenarios, it is problematic to continually measure the necessary sample media (blood, urine, serum, etc.), making the use of invasive biosensors difficult. The chemical components that are present within and on the surface of the human body may be measured in situ using biosensors for biomedical measurements. Compared to traditional instrumental analysis approaches, this is a potent tool for quickly and easily quantifying ecological information [8]. Blood, sweat, saliva, tears, interstitial fluid, breath, and human volatiles are just a few of the biological fluids that may now be detected analytically thanks to the invention of biosensors (Fig.1). [9]

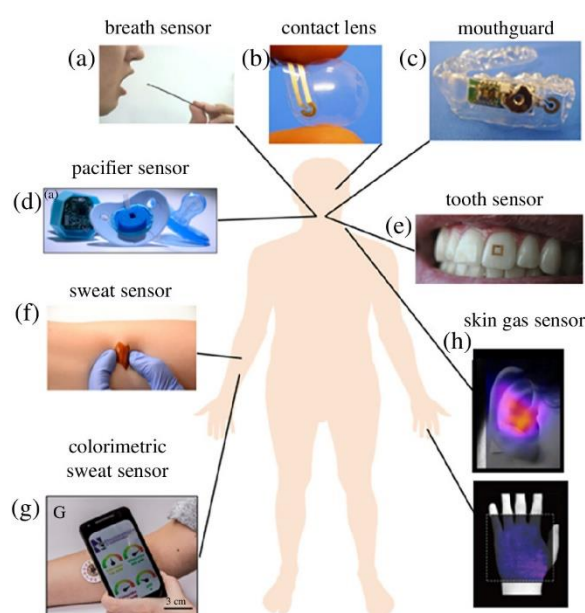

Figure 1: 1.1.1. biosensors and chemical sensors for human information

Over the last two decades, research on wearable sensors has expanded at a remarkable rate. As MEMS technology and biosensors have advanced, they have shrunk and gotten more complex.



These portable, non-invasive sensors have been used to track patients' exercise activities as well as continually monitor patients [10]. Wearable sensors may make it possible to switch from hospital intensive care to individual management at home, which is advantageous for cutting medical expenses and securing hospital beds. Wearable biosensors, in our opinion, will be extremely helpful in the ongoing care of COVID-19, and we anticipate that further research will be done in the future [11].

## **1.2 Statistical analysis of heart and blood vessel conditions.**

According to "Heart Disease and Stroke Statistics - 2015 Update: A Report from American Heart Association", the heart disease and stroke statistics are as follows:

remains the leading cause of mortality worldwide, accounting for 17.3 million deaths year and estimated to reach 23.6 million by 2030 [12]. This data was gathered from over 190 nations.

According to the same data, stroke is still the second-leading cause of death. According to the American Heart Association research, between 1990 and 2010, the number of deaths from stroke per 100,000 persons decreased. However, the number of individuals having their first and subsequent strokes each year increased, reaching 33 million in 2010 [12].

National Center for Health Statistics, World Health Organization, and National Heart, Lung, and Blood Institute

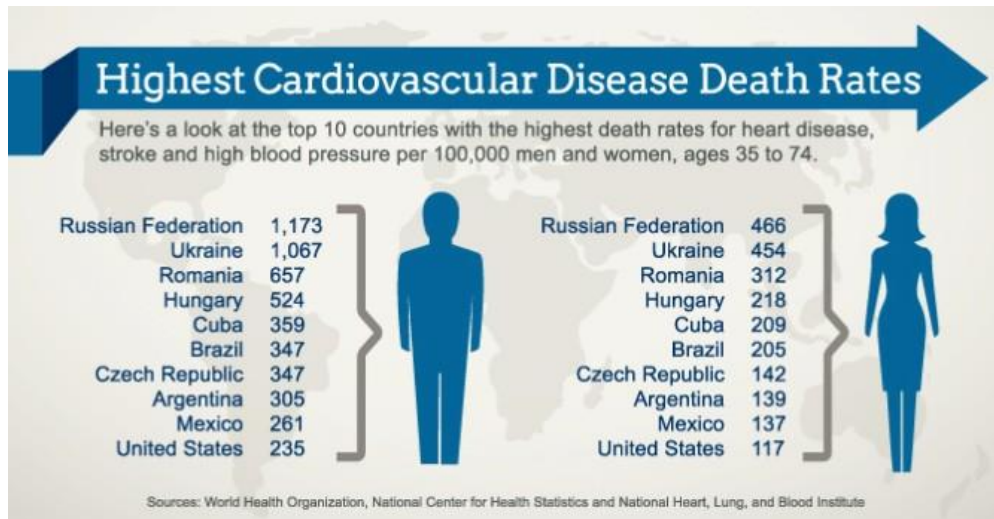

Figure 2:1.2.1.mortality rates from cardio vascular disease

### 1.3 Respiratory Disease.

The blood's oxygen saturation also plays a role in respiratory issues. According to a 1996 study, red blood cells function as biosensors that can fine-tune themselves.

To optimize the blood flow so that the organs and tissues receive the right amount of oxygen. S-nitrosothiol (SNO), coupled with oxygen, is carried in the bloodstream by blood cells. By altering the structure of the blood cells and releasing SNO, the blood flow can be controlled. When the blood's oxygen content is high, hemoglobin contains too much oxygen and NO, which decreases blood flow. NO is released to dilate blood vessels and enhance blood flow when the blood's oxygen content is low. As a result, SNO is fully depleted in blood cells that have experienced extended oxygen deprivation (hypoxia), which causes asthma and other breathing disorders.

Additionally, cardiac problems and organ failure may result from this [14].

## **1.4: Congenital Heart Defects.**

Congenital heart disease is the term used to describe structural flaws in the heart that exist at birth. Congenital cardiac disease comes in a wide variety of forms. At this point, the heart's inside walls, its internal valves, or the arteries and veins nearby or surrounding the heart, which transport blood throughout the body, may all have problems. These flaws interfere with the heart's ability to pump blood normally. Defect levels ranged from minimal to high. Some newborns or individuals with these problems require ongoing cardiac care for a continuing diagnosis and course of treatment.

Because of the aforementioned factors, the suggested strategy is advantageous and practical for the populace [15].

## **Chapter # 2: Literature Review and MainLine.**

Around the world, numerous research teams are presently developing wireless health monitoring devices. One of the most crucial aspects of life in the modern world is health care. In our rapidly changing environment, real-time patient monitoring from a distance is required for patient care.

### **2.1 Health Monitoring system:**

ECG, Pulse Rate, SpO2, Blood Pressure, and other measurements make up a health monitoring system. For hospital installations, this equipment is already readily available on the open market, and numerous studies are constantly being conducted to increase its effectiveness and accuracy.

These enormous pieces of equipment can only be used in hospitals and clinics; patients outside of hospitals cannot use them. Because of a number of factors, the production cost is considerable, making it also pricey. We began developing a portable, cheap health monitoring device for patients to use outside of hospitals due to the aforementioned reasons.

#### **2.1.1 Wireless technology implemented on Health Monitoring system:**

The wireless technology was introduced in an effort to improve patient accessibility. This wireless technology paved the way for new technology to go past the majority of its preexisting drawbacks. Even though wireless technology was used, the size was still too large for patients to make it portable, and the price was still high.

#### **2.1.2 Wearable technology implemented on Health Monitoring system:**

Several research teams are currently working on wearable and wireless technology that is integrated into a health monitoring system for the convenience of the patients. A daily wearable would have the monitoring unit implanted. By doing this, the size of the monitoring system and the cost of manufacturing can both be decreased.

### **2.1.3 Commercially available technology:**

Wearable health monitoring systems for fitness purposes are commercially available. Companies like Fitbit, Garmin, and others have already introduced their fitness-related gadgets, which keep track of a person's daily activities. There are products that use a single, straightforward led as a sensor to detect heart rate solely for fitness purposes.

### **2.2 Briefing on Biosensors:**

Traditional infectious disease diagnosis needs a centralized network of labs, takes longer, and employs more personnel. We must change the existing system into one that is rapid, quick with first treatment, and less about utilizing large lab equipment in order to establish a more complete public health system. With recent developments, the area of biosensors is prepared to provide point-of-care services that are more accurate, efficient, and affordable, as well as quick diagnostic services. Based on how well they take use of the transducing effect via optical, electrical, and mechanical sensing, biosensors are typically characterized as labeled or unlabeled [16]. In order to develop biosensors, a technical aid in nanofabrication is required. The bulk of biosensors are still only functional in research laboratories despite all of these advancements. The usual approach is to gather samples, deliver them to the lab for examination, and then hold off on making a diagnosis until the test findings are made available. In contrast, a biosensor converts the molecular recognition of the target into a measurable signal using a transducer. A simple example is a glucose sensor, which performs best when its electrodes are temporarily exposed to a patient's blood..

As was already noted, biosensors cannot be implanted within the bodies due to problems, hence they are now being tested on animals. Sweat contains a variety of salts, and in some mysterious way, it also gives a reading of temperature that is close to ideal. So, for the experimental phase of this first phase, we wanted to use such a form of customized embedded system. Our goal is to research and attempt to create a circuit of certain sensors that can be mounted on a bone and then release an initial

dose of medication when necessary or when a doctor controls it remotely. We have been searching for and reaching out to industry professionals that have experience in this field and can assist us in creating a prototype for our own original fundamental concept.

## **2.3 Attributes of Biological sensors:**

The optimization of the products is determined by characteristics and behavior. Similar to static and dynamic features, biosensors also specify their optimization and degree of dependability and reflect their performance. Below [17] is a list of a handful of them.

### **2.3.1 Dependability:**

To determine the reliability of the sensors, several experiments are run. We can observe that the value changes somewhat with each iteration. To determine whether it is producing the same results every time, the biosensor underwent a setup of repeated experiments. Two key characteristics that describe a biosensor's reproducibility are precision and accuracy. Accuracy is defined as how much the mean results are closer to the true value. Precision is defined as the identical results that a sensor receives everytime a duplicate experiment is performed. Greater accuracy results from smaller differences, and vice versa. This determines how much we may trust the results of the biosensor in terms of reliability. Robustness's primary building block is reliability.

### **2.3.2 Consistent Linearity:**

In mathematics, linearity is essentially the same concept. We measure the difference between the results and a straight line representing the genuine values. This shows how accurate the biosensor is.

In mathematics, the straight line is described by the equation

$$Y=mc.$$

The following parameters are defined by this equation.

- Y denotes the signal's output.

- The intensity of the analyte in the sample is represented by the letter "c."
- The biosensor's sensitivity is represented by the number m. (To be covered later)

Resolution and linearity are related. The lowest variation in analyte intensity necessary to cause a change in the biosensor's response is referred to as resolution. The majority of the time, the objective is to quantify both the specific analyte and its concentration. Resolution is therefore crucial in this regard. A biosensor that has a high resolution factor can identify even the tiniest changes. "Linear Range" is a different phrase related to linearity. It basically explains how much variation a biosensor can withstand while still maintaining its linear behavior.

### **2.3.3 Sensitivity:**

The limit of detection is another name for sensitivity. This is, as the name suggests, the smallest quantity of the sample that a biosensor can detect in a fluid combination. It is one of the most crucial characteristics of the biosensor. A sensor must be able to detect a substrate in various medical samples at concentrations as low as ng/ml and even lower. In other words, sometimes there are only very little amounts of the analyte in the sample, and the sensor must find those very small amounts. The majority of sensors struggle to balance sensitivity and accuracy. As a result, these parameters can be traded off to get results that are optimum.

### **2.3.4 Stability:**

The extra component is present in the sample together with the target one when a biosensor is exposed to it. As a result, the outcome may contain anomalies due to these additional factors. The ability of a biosensor to withstand these kinds of environmental changes is referred to as stability. This is the most important characteristic since it determines whether the biosensor can make a live guess. The sensor's electronics and their tuning are responsible for stability. To keep the sensor reliable, properly tuned electronics components are essential. The credibility of the bioreceptor over time may also be a contributing factor. Thus, stability may eventually be jeopardized.

### 2.3.5 Specificity:

It is a biosensor's capacity to accurately detect the analyte that we want to analyze. It is one of the essential traits. The biosensor need to be capable of picking out a particular analyte from a mixture.

### 2.4 Basic Idea:

Different methods can be used to represent the system's circuits. Depending on the needs, many sensor types and communication channels may be used. As a result, the circuit modeling shown in figure 3 follows our criteria

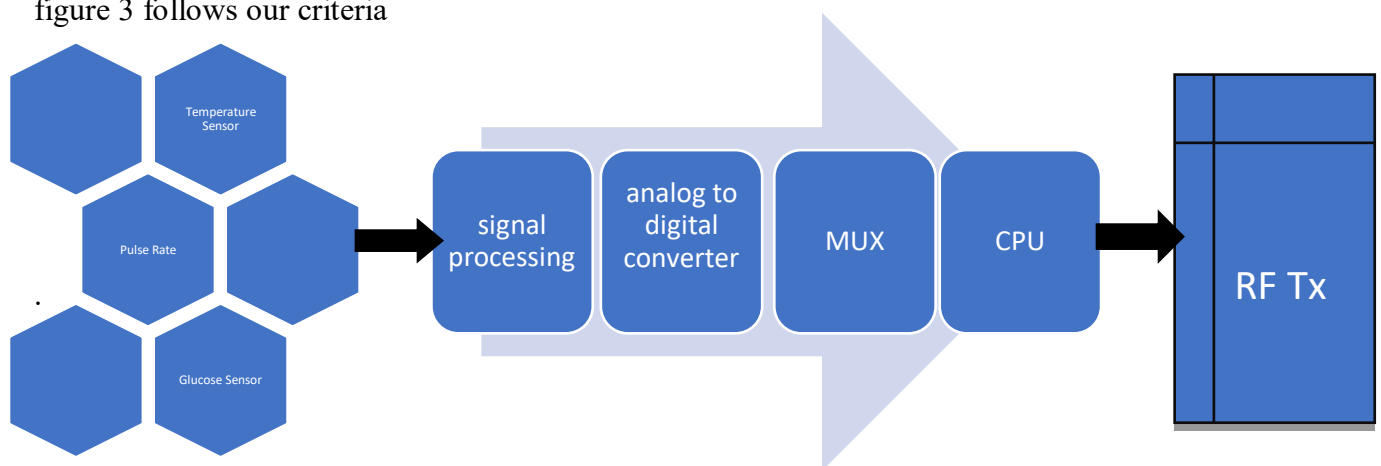

Figure 3:2.4.1. Transmitter side

The signal processing unit is aligned with a variety of sensors. This unit analyzes electrical signals coming from sensors and feeds the signal responses to the microcontroller, which then makes the necessary calculations. This information is then delivered to the receiving end, where it is watched over and recorded for later use. Figure 4 displays the receiver side operations.

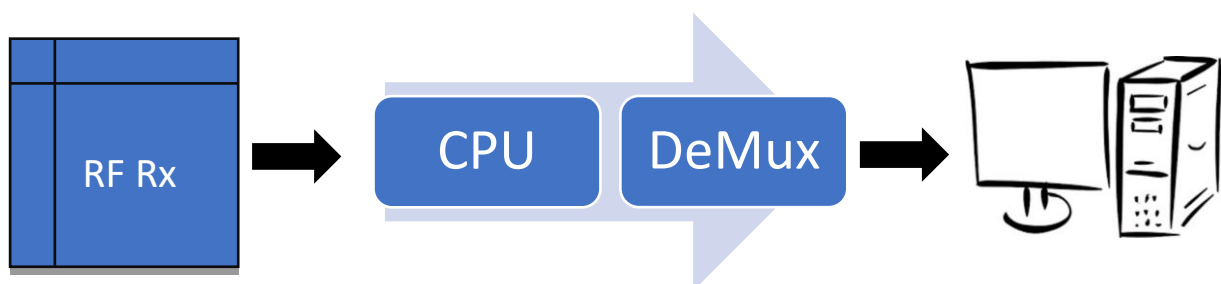

Figure 4:2.4.2. Receiver side



The data is sent into the microcontroller, where it is decoded as necessary before being transferred to the PC so it may be recorded and saved as a patient history. In simple terms, we may say that:

- 1) The transmitter electronics' associated sensors.
- 2) The computer's receiver
- 3) Simple SW to gather this data on a computer.

## **2.5 Sensing devices and their categories:**

Sensors are tools that track environmental changes and translate them into a corresponding analogue electrical signal. The environment that sensors are exposed to determines changes. They can be dynamic like a shift in frequency or light, or mechanical like stress, warmth, vibrations, etc. Then, bits representing the matching analog electrical signal are transferred. Before the transmission, the requisite analogue to digital conversion process was completed. Biosensors can be categorized into the following types [17] depending on the transducer's kind and activity.

Biosensors with thermal,

Optical biosensors,

electrochemical, and ion sensitivity biosensors.

Piezoelectric biosensors

Here are a few different kinds of biosensors. The biosensors can serve a variety of purposes, such as those connected to tissue and enzymes, as already mentioned in the criteria for the types. The sensors that are researched and some of which are used in simulation are listed below.

### 2.5.1 Ph sensor:

Ph is just a scale that measures how acidic and basic a solution is. It has a sensor and a glass electrode in the shape of a rod of glass. The relative Ph units tended to change when hydrogen ions moved between the electrodes [18] .

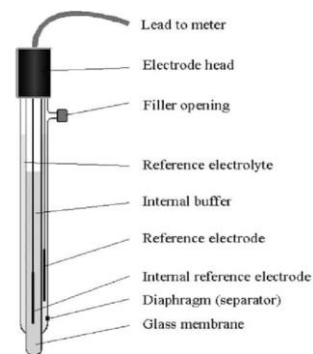

Figure 5:2.5.1.1.pH sensor

### 2.5.2 Oxygen saturation (SpO2) and pulse oximetry:

SpO2 is a measurement of the blood's oxygen content. The blood contains both oxygenated and deoxygenated types of hemoglobin. The following formula is used to determine the results:

$$SpO_2 = 100 * \frac{C(HbO_2)}{C(HbO_2) + C(RbO_2)}$$

- Oxygenated hemoglobin (HbO2)
- Deoxygenated RhO2 Hemoglobin

The change in transmission modulation and light sensor absorption in arterial blood are what allow for the measurement of pulse rate [19].



Figure 6:2.5.2.1.MAX32664D

### 2.5.3 Thermal Sensor:

One of the vital signs that shows numerous anomalies in the area where it rises or falls is temperature. A rise in temperature typically makes the affected region visible. There are various kinds of temperature sensing devices, including those that use infrared light and others that employ diodes, where the voltage across the diode grows as the temperature rises. In the simulation, I utilized the LM35, which operates on the rise in voltage across the diode principle [20].

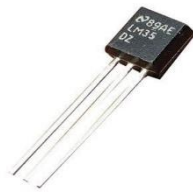

Figure 7:2.5.3.1.LM35

## **2.6 Selectivity and Sensitivity of Biosensors:**

Every technology that has been created over time has flaws and restrictions. A few significant topics pertaining to biosensors are covered here [21].

### 2.6.1 Precision:

One of the primary elements regarded as having a connection to technology is this. Because a variation of a few percentage points in the concentration of salt or another substance that is intended to be measured might have significant effects, biosensor precision should be high. Because of the field, inadequate calibration might potentially impair precision.

### **2.6.2 Sensing Time:**

The sensor should be capable enough to identify and measure the strength of objects that are exposed to it quickly. It could be tissues, enzymes, or proteins. Reduced detection times shouldn't come at the expense of sensitivity.

### **2.6.3 Detection Threshold:**

The smallest quantity of an analyte concentration that can be detected and distinguished from zero is known as the detection limit. During a biochemical reaction, the sensor's capabilities should be sufficient to identify the target that is present in the mixture.

### **2.6.4 Peculiarity:**

As stated in the definition, the sensor must be sophisticated enough to distinguish between biological entities that are targets and those that are not. It significantly affects sensitivity as well. It is regarded as the sensor's most crucial feature.

## **2.7 Nanomaterials and biological sensing:**

Without a discussion of nanotechnology, a biosensor is not complete. The revolution in the larger-scale practical application of biosensors has been greatly aided by nanotechnology. Nanotechnology deserves all the credit for the reduction in biosensor size while retaining quality and communication elements like signal to noise ratio. It assists us in advancing to the micro- and nanoscale, which has the impact of lowering costs and raising performance.

Nanomaterials are the cornerstone of nano biosensors. The mechanical and electrical properties of these materials are used to enhance the sensors' biological signaling and transducing capabilities. There is an increase in improved detection and higher sensitivity due to the very practical electron movements in these materials. On the one hand, we may argue that nanotechnology-based biosensors reflect the confluence of molecular engineering, material science, and biology. On the

other hand, it shows an increase in sensitivity and specificity in the identification of the analyte in a range of sectors, including clinical research, illness detection, food and environmental monitoring, and environmental monitoring. [22].

## **2.8 Nanomaterials Framework- Key constituents in Bio-analytical**

### **Devices:**

Standard materials were employed in the creation of common electronics components. These materials cannot be used in the construction of nanotechnology. Due to the fact that materials' sensitivity is a property that varies with their size. For instance, a given material's surface area is not as effective at smaller sizes as it is at nanoscales. We can more precisely and at a smaller volume increase the bioreceptor's low level immobility thanks to nanomaterials. The properties of gold nanoparticles, carbon nanotubes, quantum dots, and nanodiamonds are excellent, and these materials are in high demand as study subjects. The list of some of them is shown below [23].

### **2.8.1 Gold Nanomaterials:**

The high biocompatibility of gold nanoparticles makes them compatible with live tissue. When introduced to the body, they have no negative effects. They also have electrical and optical features in addition to biocompatibility. Redox enzymes biosensing is mostly the theory employed when gold particles are present. Redox is a combination of the terms "oxidation" and "reduction." The first one shows when oxygen is added, and the later one shows when oxygen is removed when detecting reactions occur. This method's disadvantage is that only a small number of the ions make it to the solution; the most are absorbed in the electrodes. Depending on the type of application, the size typically ranges from 1nm to 100nm.

### **2.8.2 Quantum Nanoparticles:**

A particular group of substances known as luminous semiconducting nano crystals includes quantum dots. Quantum dots made of cadmium have a broad absorption window and a constrained emission window. Because these are nanocrystals, the crystal lattice can occasionally get broken, which can lead to the trapping of exiting electrons. These electrons don't emit any energy as they transition to their relaxed state. The optical qualities may be compromised as a result.

### **2.8.3 Carbonaceous Nanoparticles:**

Covalent bonds play a major role in the formation of carbon in nature. When formulating a strategy for immobilization, the covalent characteristics are taken advantage of. These structures are both biocompatible and have good electrical characteristics. The fundamental component of field effect transistor-based biosensors is the carbon nanotube.

One of the most difficult aspects of creating the biosensor is immobilizing enzymes on the transducer's surface. There are various methods for immobilization, including trapping, covalent bonding, cross-linking, and traditional adsorption. Adsorption simply entails mixing the analyte and chemical to create a slurry that will be placed to the sensor's surface and allowed to settle for a predetermined amount of time. The easiest example for us to understand is determining the proper blood group. Covalent immobilization is the most widely used technique because it creates a solid link between the enzyme and the support matrix, which stops enzyme leakage.

## **2.9 Bio-Monitoring system and Cyber protection:**

The internet of things is a concept that includes biosensor systems on chips, and because of their intricate architecture, they are vulnerable to security risks. For safeguarding the IOT domain, numerous risk assessment frameworks have been created throughout time. NIST, OCTAVE, TARA, and a long list of other frameworks are only a few examples. The advancement in this area also raises the danger of malware, phishing, and incorrectly designed databases. The task's real-time

monitoring of medical equipment introduces a possible security risk that could tamper with electronic health records and harm the device's circuitry. Furthermore, telemedicine and remote surgery must be sufficiently secure so as not to jeopardize patient security and privacy.

In light of the device's potential for producing the worst-case result for a patient, a risk management system has been suggested. Microsoft has created a stride model that can evaluate threats [24]. The NIST offers the most popular risk management framework, which operates in the manner described below:

- Identify
- Protect
- Detect
- Respond
- Respond
- Recover

The main goal of this framework is not to provide a checklist of things to do, but rather to inform us of potential cybersecurity consequences that will assist the stakeholder in managing the issue. The following four components make up core [25]:

### **2.9.1 Purposes:**

They typically proceed in the order outlined above, maintaining the highest priority level. They support the organization's efforts to solve the issue by gathering and classifying data, enabling risk management decisions, and drawing lessons from past experiences.

### 2.9.2 Classes:

The categories into which the functions are further separated are primarily related to programmatic needs and specific actions. The administration of assets, the detection process, and access control are primarily included.

### 2.9.3 SubClasses:

These are how the categories are further divided. To support the outcomes of each category, they present a collection of findings. It mostly entails cataloging external information, evaluating notification from the system, and safeguarding static data.

### 2.9.4 Information Repository:

These are the rules and specifications that specify a complicated process to produce the results relevant to each category.

## 2.10 Implications of Biosensors:

From a commercial and scientific viewpoint, biosensors are undeniably interesting due to the amount of literature linked with them.. The effects of biosensing are not just seen in the medical field; they are also becoming more significant in safety requirements for water quality, environmental monitoring, and food nutrition regulation.

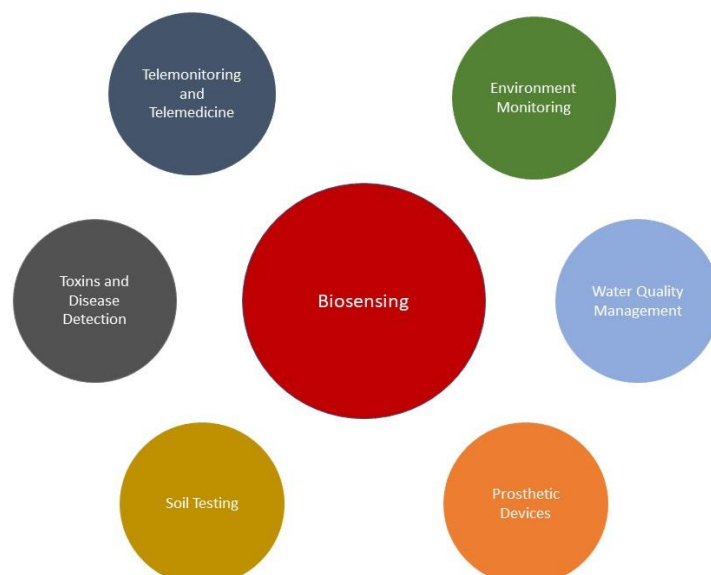



Biosensors have given humans autonomy and enabled them to analyze and manage situations according to their conditions. The best example is the glucometer. The 3D printed prosthetic devices have also made it possible for everyone to work hard in a variety of spheres of life.

## **Chapter # 3: Modelling And Simulation.**

### **3.1: Test Environment:**

A simple schematic is created in Proteus to help explain how biosensors function. Labcenter Electronics Ltd. created the Proteus design suite, which enables the design and simulation of electrical circuits. It is essentially a collection of real-world electrical objects. a variety of microcontrollers, starting with a set of resistors. Additionally, it permits the creation of a printed circuit board (PCB) layout that can be quickly applied to physically realize the following design. We can also flash the microcontrollers thanks to it. In order to save the findings, I've utilized a data logging device, a temperature sensor, and a heartbeat sensor in this scheme.

### **3.2: HeartBeat Sensor.**

One such sensor, the heart rate pulse sensor amp, is primarily used to measure heartbeat frequency. Normally, it is really challenging to determine an accurate heartbeat rate, but with the aid of this pulse sensor amplified, it has been much simpler. If we are talking about the heartbeat, then the heartbeat is a periodic signal that is generated by any hardware or software system in order to provide information about the typical operation of any system. Many other sensors are now being used in the market to measure this periodic information stream, but we will just discuss pulse sensor amplified in this article. This heartbeat sensor is just plug-and-play, and makers, athletes, game developers, and students have used it in hardware projects. It is freely accessible in stores and online. Figure 8 displays a simple heartbeat pulse sensor.



Figure 8:3.2.1. Simple heart beat sensor

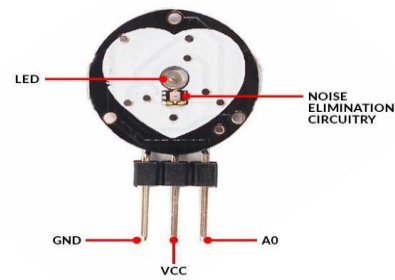

Figure 9:3.2.2. Pin Configurations

There are three pins on each heart rate sensor. The first one is the ground pin, which is linked to the source ground pin and is utilized to deliver ground to this sensor. The second one is the VCC pin, which is linked to the source VCC pin and is utilized to power this heart rate sensor. Nearly 3.3V to 5V dc voltages are used to power this sensor. Similar to the previous one, the last one is A0 pin, an analog pin that receives analog signals. Figure 9 depicts the pin layout of this heart rate sensor.

Figure 9 shows that this sensor also has a center LED. This LED facilitates the sensor's ability to measure heart rate. Another circuitry, known as noise removal circuitry, is located underneath the LED in addition to this one. This circuitry is used to reduce noise that affects how the heart rate pulse sensor reads. You place your finger on the sensor's front, which has the heart logo. Additionally, you'll see a little circular aperture where the Kingbright's green LED with reverse mounting shines. A tiny ambient light photo sensor, the APDS-9008 from Avago, is located just below the circular hole. This sensor works similarly to those found in laptops, tablets, and mobile devices in that it adjusts the screen's brightness in accordance with the ambient illumination. The R/C filter network is made up of a Microchip MCP6001 Op-Amp, a few resistors, and capacitors, and is located on the rear of the module. In case the power lines are mistakenly reversed, there is also a reverse protection diode to guard against harm. [26]

### 3.2.1: LM35.

The LM35 temperature sensor is reasonably accurate, never breaks down, operates in a variety of climatic situations, and doesn't need any additional parts to function. Additionally, the LM35 sensor doesn't need to be calibrated and has a typical accuracy of  $0.5^{\circ}\text{C}$  at ambient temperature and  $1^{\circ}\text{C}$  across the whole temperature range of  $55^{\circ}\text{C}$  to  $+155^{\circ}\text{C}$ .

The sensor may be supplied by a 4V to 30V power source and has extremely low self-heating (less than  $0.08^{\circ}\text{C}$  in still air), using less than 60A during active temperature conversions. [27]

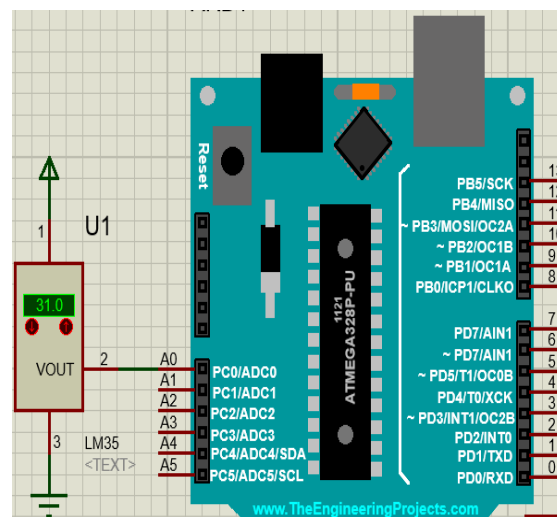

Figure 10:3.2.1.1.LM35connected with microcontroller

- As you can see in the above image, I have connected an LM35 sensor with Arduino UNO.
- The VCC pin of LM35 is connected to +5V of the Arduino board.
- Since LM35 generates an analog value at its output pin that's why I have connected this pin to the 'A0' pin of the Arduino board.
- This pin of Arduino board is used to receive analog data from an external source.
- And the last pin is connected to the GND pin of the Arduino board.

### 3.2.2: Display segment.

There is also a display portion where you may observe the reading of a real-time clock. The outputs that are flowing through the microcontroller in real time are checked using a real time clock. After a certain amount of time, the microcontroller transmits the reading, and the RTC monitor displays the reading at the end of each delay period. A liquid crystal display that shows the measurement over time is also attached to the RTC.

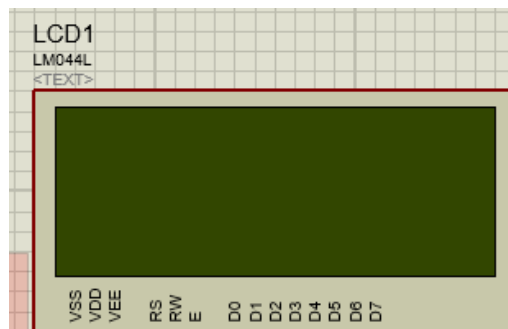

Figure 11:3.2.2.1.display segment

### 3.3: Microcontroller.

The Arduino ATmega328P is a microcontroller board based on the ATmega328P microcontroller chip. It's one of the most popular microcontrollers used in the Arduino ecosystem, and it forms the heart of many Arduino boards like the Arduino Uno and Arduino Nano. Let's delve into some details and the working principle of the ATmega328P microcontroller:

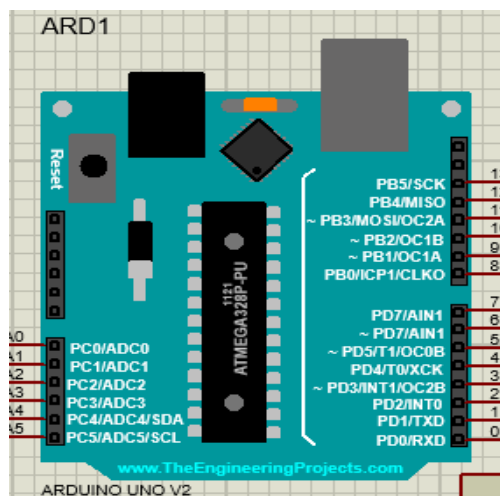

Figure 12:3.3.1.Microcontroller ATMEGA328p

### 3.3.1. Details about ATmega328P:

Microcontroller Model: ATmega328P

Architecture: 8-bit RISC

Clock Speed: 16 MHz (can be configured for lower frequencies)

Flash Memory: 32KB

SRAM: 2KB

EEPROM: 1KB

I/O Pins: 23 (including 6 analog inputs)

Operating Voltage: 5V (compatible with 3.3V logic)

Communication Interfaces: UART, SPI, I2C

Power Supply: Typically powered via USB or an external power supply

### 3.3.2. Working Principle:

The ATmega328P is at the heart of many Arduino boards, and it operates based on a few key principles:

- **Clock and Timing:** The ATmega328P relies on an external 16 MHz crystal oscillator or an internal oscillator for its timing. This clock signal regulates the execution of instructions and the operation of various peripherals.
- **Memory:** It has 32KB of Flash memory for program storage, 2KB of SRAM for data storage, and 1KB of EEPROM for non-volatile data storage.
- **Input/Output (I/O):** The ATmega328P has a variety of digital and analog I/O pins that can be configured as inputs or outputs. These pins can be used to interface with sensors, actuators, and other devices.
- **Communication Interfaces:** It supports UART (Serial), SPI (Serial Peripheral Interface), and I2C (Inter-Integrated Circuit) communication protocols, allowing it to communicate with other microcontrollers, sensors, and modules.

- **Program Execution:** Programs are written in the Arduino IDE using a simplified C/C++ programming language. The Arduino bootloader and programming circuitry make it easy to upload sketches (code) to the ATmega328P via a USB connection.
- **Peripherals:** The ATmega328P has built-in timers, PWM (Pulse Width Modulation) controllers, analog-to-digital converters (ADCs), and other peripherals, making it versatile for various applications.
- **Power Management:** It supports various power-saving modes to optimize power consumption, which is crucial for battery-powered and energy-efficient applications. [29]

### **3.4 ESP8266-01 module:**

A common Wi-Fi module used in several Internet of Things (IoT) applications is the ESP8266-01 module. It may not, however, be immediately accessible in the Proteus simulation program. So we simply import the library for this module to accessible on Proteus. Here are some specifics of the ESP8266-01 module's operation's theory: [30]

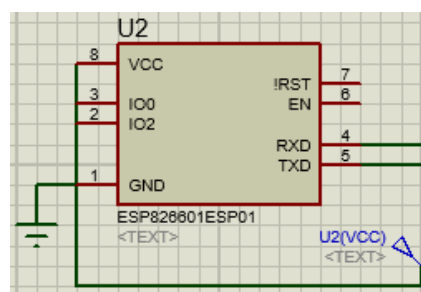

Figure 13:3.4.1.ESP8266-ESP-01 module for wifi connectivity

#### **3.4.1 Details of ESP8266-01.**

The ESP8266-01 is not a microcontroller itself but a module that integrates the ESP8266 Wi-Fi chip. The ESP8266 chip has its own microcontroller. It provides IEEE 802.11 b/g/n Wi-Fi connectivity. Typically operates at 3.3V, so level shifting might be required for interfacing with 5V logic devices. UART (Serial), GPIO pins. Usually comes with 1MB of flash memory. Often has an

onboard ceramic antenna. Varies depending on usage but can be relatively low when in deep sleep mode. We can program the ESP8266 module with custom firmware or use popular firmware like NodeMCU or Arduino's ESP8266 core.

### **3.4.2 Working Principle.**

- **Initialization:** When powered on, the ESP8266 module initializes its Wi-Fi hardware and establishes a connection to a Wi-Fi network, which can be a home network, hotspot, or an access point.
- **AT Commands:** The ESP8266 module can be controlled and configured using AT commands sent over a serial interface (UART). These AT commands allow you to set up the Wi-Fi parameters, connect to networks, and perform various networking tasks.
- **Data Transfer:** Once connected to a Wi-Fi network, the module can send and receive data over the internet using protocols like HTTP, MQTT, or other custom protocols. It can act as a web server, client, or perform other network-related tasks.
- **GPIO Control:** The module often has GPIO pins that can be used to interface with sensors, actuators, and other devices. You can control these GPIO pins via AT commands or by uploading custom firmware.
- **Power Management:** To optimize power consumption, the ESP8266 module can enter deep sleep modes when not actively transmitting or receiving data, making it suitable for battery-powered applications.

### **3.5: Simulation and Results.**

By connecting the components and microcontroller, the testbed is set up. As soon as the simulation began, the serial monitor began updating itself with the most recent data. The following image shows the whole configuration.



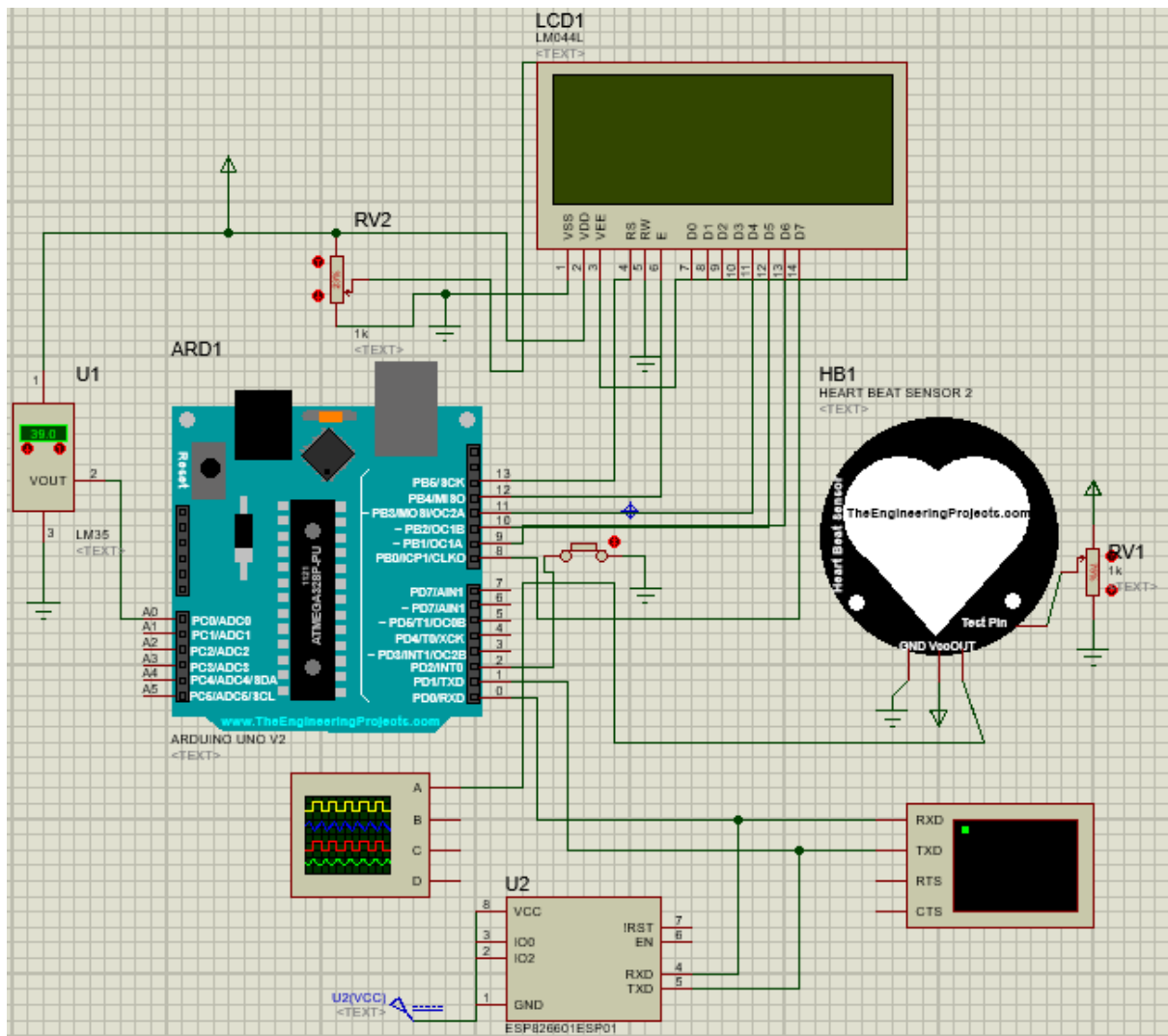

Figure 14:3.5.1.Smart patient Health monitoring system|proteus simulation

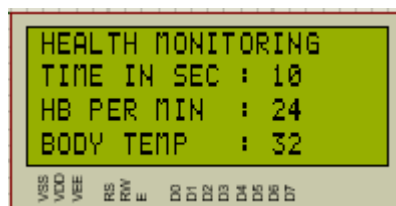

Figure 15:3.5.2.LCD unit

Since there is no actual source that we can use in the simulation to get the pulse rate, we have built up an oscilloscope across the heartbeat sensor for the virtual ECG, which displays a fictitious reading. The oscilloscope result is shown below.

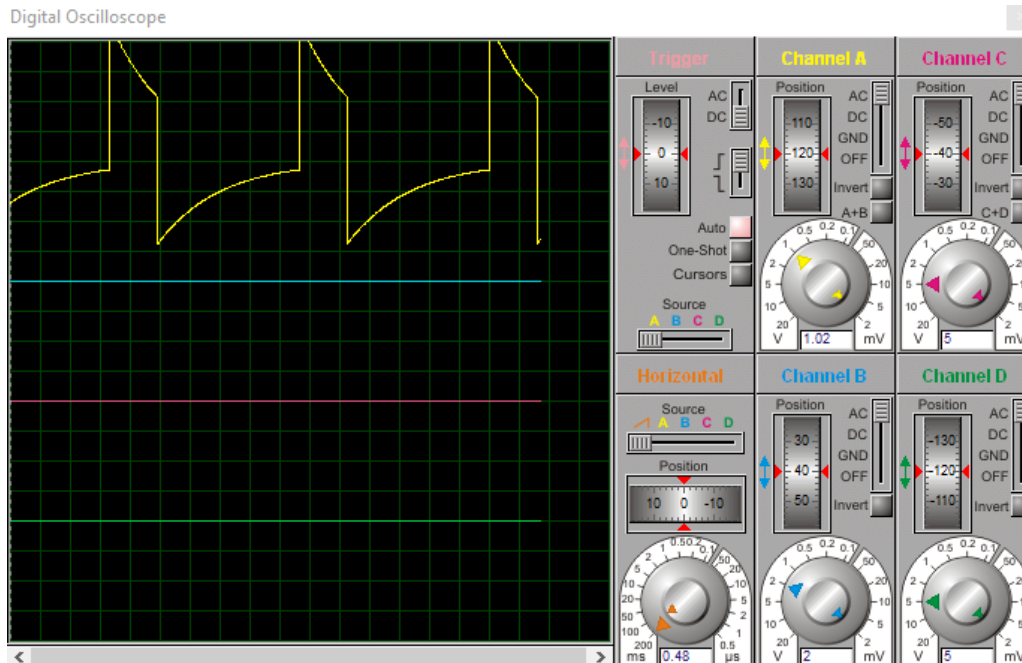

Figure 16:3.5.3.Digital Oscilloscope

Also we can share data on cloud plat-form . In this case I used Thingspeak IoT analytics platform service that allows us to aggregate , visualize, and analyze live data stream in the cloud with the help of ESP8266 Wi-Fi module.

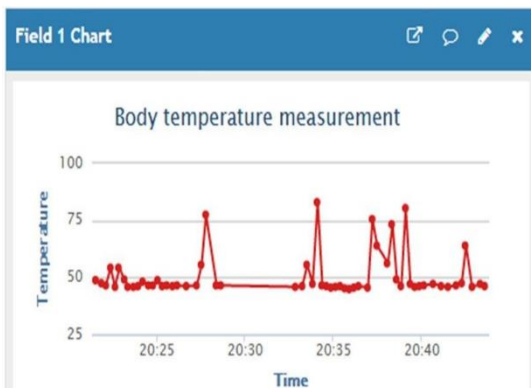

Figure 18:3.5.4.Temperature graph

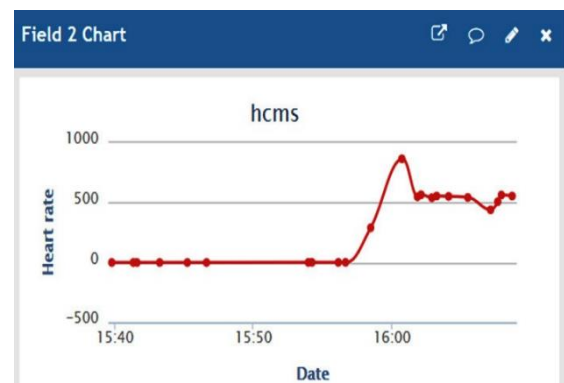

Figure 17:3.5.5.Heart rate graph

This simulation is being used to better understand how things operate. the manner in which each sensor was incorporated. how much of the voltage is used in the divider circuit.

### 3.6 Experimentation:

After finishing the simulation, I also conducted several tests in real time. I utilized a commercially available circuit on chip device that is already configured for biosensing for this purpose.

#### 3.6.1 Ph Sensor:

In my research, I am using Ion-selective electrodes approach to find a pH values for different liquids. ISEs are the electrochemical ion sensor that convert the activity of target ion into an electrical potential as the measureable signal.

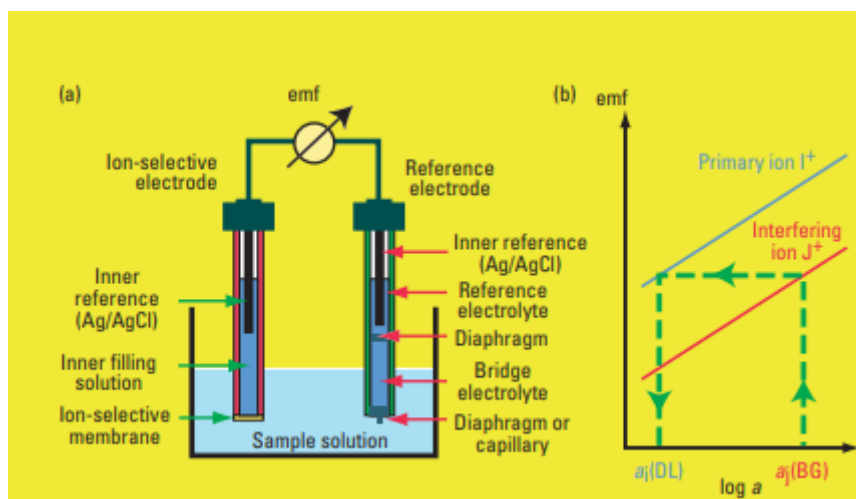

Figure 19:3.6.1.1. How Electrodes work

An indication and a reference electrode are shown in the (a) schematic of a potentiometric cell. (b) Calibration curves for an interfering cation (red) and a primary cation (blue) with the same charge. The selectivity is measured by the emf shift between the two curves. A change of 178 mV, for instance, indicates that the analyte ion prefers the interference by three orders of magnitude. The lowest potential (horizontal green dotted line) that may be measured in these circumstances is defined by the background activity of interfering ions,  $a_j$  (BG). In the presence of the background, this potential indicates the principal ion's (DL) best practicable detection limit. Transmembrane ion fluxes make it common in practice to miss this detection limit. [31]

### 3.6.2 Basics:

Potentiometric sensors are basically passive electrochemical devices that measure variations in the electromotive force (emf) at almost zero current levels. In so-called direct potentiometry, the optimal way to analyze the emf in the presence of other ions is to make it a function of the activity of only one specific sample ion. The primary goal of research in this area has long been to achieve sufficient selectivity to detect one ion in the presence of others [32]. The fundamental idea is likely best shown by ISEs with polymeric membranes, which are presupposed to behave as very viscous organic liquids. This category of sensors is now the most established and multifunctional. [33].

### 3.6.3 Product description.

The pH sensors from Zimmer and Peacock may be used in discrete mode with samples delivered to the electrode region or in continuous monitoring applications in a flowing liquid. The solid state pH sensors of the ZP are reliable. These pH sensors are composed of inorganic materials that don't contain liquids, therefore they endure a very long time even when not well stored.. [34]

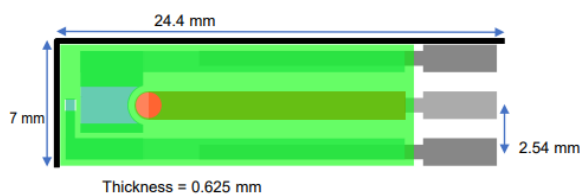

Figure 20:3.6.3.1.Mechanical drawing

Range	2 – 10 pH
Resolution	60 mV/pH
Accuracy	+/- 15 mV
Temperature	18-25°C
Theoretical Temperature coefficient	86 $\mu\text{V}/^\circ\text{C}$
Dimensions	7x24.4x0.625 mm
Weight	0.414 g +/- 2 mg

Figure 21:3.6.3.2.Specification of pH sensor

In the chart below taken the raw data from the experiment and plotted the signal (milliVolts, mV) versus the pH. From that we have calculated sensitivity of 51 mV/pH/

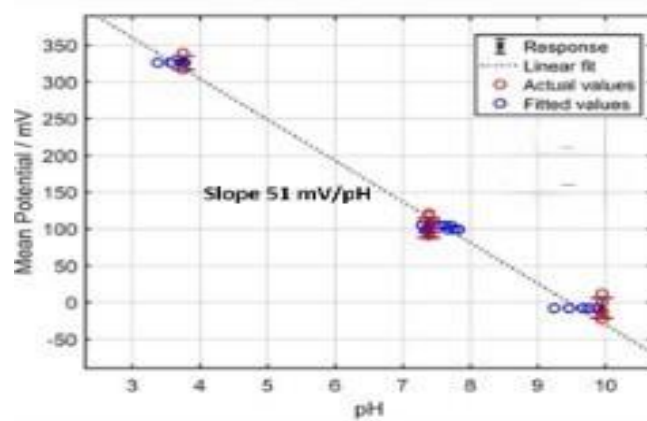

Figure 22:3.6.3.3.signal milivolts vs pH [20]

The results for a ZP pH sensor operating continuously for 27 minutes are shown in the image below. In order to observe the sensor reacting (y axis mV), the scientist altered the pH over the course of 27 minutes by adding acid and base. According to the data, the pH sensor may be employed as a discrete measuring device, such as to detect a drop of blood and then discard it, or as a continuous sensor in a liquid that is flowing, etc.

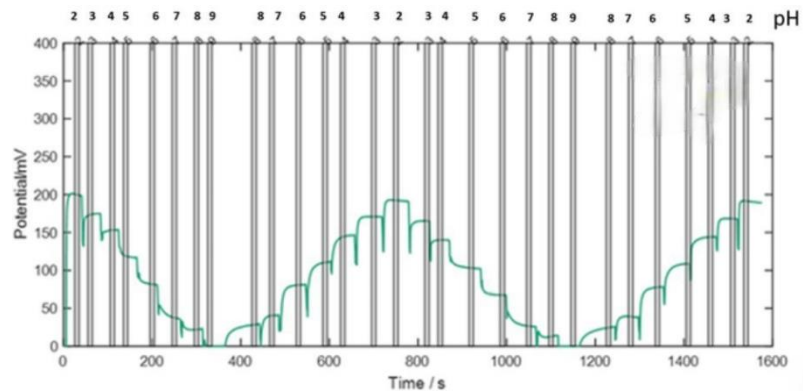

Figure 23:3.6.3.4.27 minutes testing results graph [20]

The solid state pH sensors from the ZP are stunning in their durability. These pH sensors are composed of inorganic materials that don't contain any liquids, thus they may be stored carelessly and still function for a very long time.

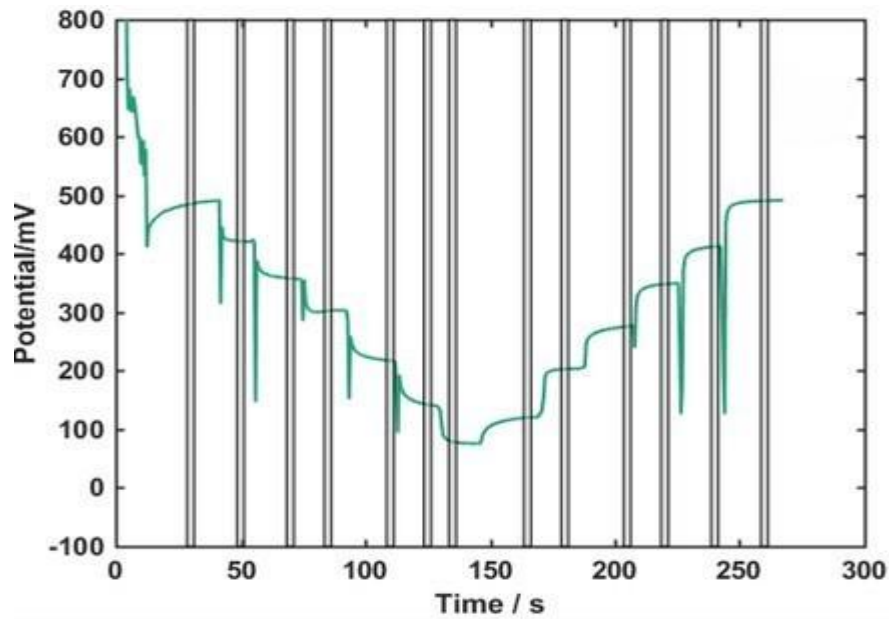

Figure 24:3.6.3.5.pH sensor after few days storage at room temperature [20]

### 3.6.4 GFET ADUCM355 BOARD.

The ADuCM355 is an on-chip system that controls and measures electrochemical sensors and biosensors. The ADuCM355 is an ultralow power, mixed-signal microcontroller based on the Arm® Cortex™-M3 processor. The device features current, voltage, and impedance measurement capability. The ADuCM355 operates from a 2.8 V to 3.6 V supply and is specified over a temperature range of  $-40^{\circ}\text{C}$  to  $+85^{\circ}\text{C}$ .



Figure 25:3.6.4.1.GFET module

### **3.7 Procedure.**

1. Attach the ZP pH sensor to the GFET connection.
2. Attach the GFET to the PC using a micro USB cord.
3. To see the data from GFET, I utilized the freeware TeraTerm. The required baudrate is 57600bps.
4. The pH measurement data in volts are presented in the user interface after the instrument is connected. The data may then be processed and visualized using Python script or Microsoft Excel.

#### **Conversion Formula:**

After taking a results in volts use this formula to convert in pH value for each liquid

$$\text{pH} = 7 - \text{millivolts} / 57.14$$

0 pH	+400mV
1 pH	+342.86 mV
2 pH	+285.71 mV
3 pH	+228.57 mV
4 pH	+171.43 mV
5 pH	+114.29 mV
6 pH	+57.14 mV
7 pH	zero mV
8 pH	-57.14 mV
9 pH	-114.29 mV
10 pH	-171.43 mV
11 pH	-228.57 mV
12 pH	-285.71 mV
13 pH	-342.86 mV
14 pH	-400 mV

*Figure 26:3.7.1.results of pH values*

## **Chapter# 4**

### **Conclusion:**

The creation of biosensors is a subject that interests many people, and during the last several years, significant progress has been achieved in this field of study. A relatively small number of biosensors have been globalized at the retail level despite all of this growth. There are a few causes for this. One of them is the challenge of turning academic research into an industrially viable prototype. Making a biosensor requires more than just one hand. The departments of material engineering, biomedical engineering, biochemistry, embedded systems, and communication engineering, among others, each play a part in transforming a research model into a prototype that can be used in the marketplace. The manufacturing process should put out the same level of effort and research funds as the academic research. As a biosensor, it is necessary to first recognize the analyte molecule before immobilizing it to the sensor surface. Device design, including elements from several disciplines while satisfying biological facts and statistics. The testing of thousands of prototypes leads to the final product. Along with this, there are several other aspects, including cost, manufacturing process simplicity, and stability.

As of now, in vitro biosensors have a significant ability to digitize medical care. They have a significant influence on many facets of our lives, including telemedicine, health monitoring, and the regulation of food and water purity. Many factors contributed to this field's quick growth, but the following are the most significant ones:

- The identification of appropriate biorecognition entities.
- Technological advancements in the area of nanofabrication
- Nanomaterials and the creation of goods with nanostructures.
- Improved communication between engineers and medical scientists.



It is more probable that we will develop a system on chip that can draw and handle the raw samples directly in this decade, even if the work that has been done up to this point has enabled us to undertake in vitro biological diagnostics. By expanding the number of samples that can be handled by a single chip system, the search to reap the most advantages may now be carried out. In a word, we may claim that by conquering nanopore technology, the goal of a \$100 personal genome can be achieved in this decade.

The current COVID-19 epidemic highlights the need for us to comprehend the critical function of biosensing and alter our strategy for managing the medical crisis in a more efficient and secure manner. The nations employing a biosensing technique have managed the issue far better, according to data analysis on the pandemic's fatality rate.

## Bibliography

- [1] c. M, Ursache der elektromotorischen Eigenschaften der Gewebe, *zugleich ein Beitrag zur Lehre von den polyphasischen Elektrolytketten*, p. 562–608, 1906.
- [2] H. W.S, The potential difference between glass and electrolytes in contact with the glass.,in *J. Am. Chem. Soc.*, 1922, p. 44:2860–2867.
- [3] G. E. Nelson J.M., Adsorption of invertase. *J. Am. Chem. Soc.*, p. 38:1109–1115, 1916.
- [4] J. W. L. C. C. J. Heineman W.R., *Biosens. Bioelectron*, p. 21:1403–1404, 2006.
- [5] N. H. G. W. J. A. Yu Y, Flexible electrochemical bioelectronics., *The rise of in situ bioanalysis*, p. (15): 1–25, 2020.
- [6] W. J. Windmiller JR, Wearable electrochemical sensors and biosensors.,*A review. Electroanalysis*, p. 25(1): 29–46, 2013.
- [7] H. F. E. N. S. N. Pickup JC, Biosensors and Bioelectronics, *In vivo glucose monitoring: The clinical reality and the promise*, p. 20: 1897–1902, 2005.
- [8] M. A. A. S. Albareda-Sirvent M, Sensors and Actuators,*Configurations used in the design of screen-printed enzymatic biosensors*, p. 69(1): 153–163, 2000.
- [9] C. P. T. K. A. T. M. K. Ye M, Biosensors and Bioelectronics,*An acetone bio-sniffer (gas phase biosensor) enabling assessment of lipid metabolism from exhaled breath*, p. 73: 208–213., 2015.
- [10] S. T. P. V. B. A. D. M. Yokus MA, Biosensors and Bioelectronics,*Wearable multiplexed biosensor system toward continuous monitoring of metabolites*, no. 2020, p. 153:112038, 2019.
- [11] L. D. R. S. L. Y. K. N. Xu L, Biosensors and Bioelectronics, *Xu L, Li D, Ramadan S, Li Y, Klein N. Facile biosensors for rapid detection of COVID-19*, p. 170:112673, 2020.
- [12] Heart disease and stroke statistics—2015 update: a report from the American Heart Association.[published online ahead of print December 17,2014]. *Circulation*. doi: 10.1161/CIR.000000000000152..
- [13] <http://blog.heart.org/american-heart-association-statistical-report-tracks-global-figures-first-time>.
- [14] Duke University Medical Center. (2005, October 10). Discovery Links Blood Cell Defect To Common Lung Disorder, Leads To Novel Treatment.ScienceDaily, Retrieved November 28, 2015 from [www.sciencedaily.com/releases/2005/10/051007094528.htm](http://www.sciencedaily.com/releases/2005/10/051007094528.htm).
- [15] What Are Congenital Heart Defects?, National Heart, Lung, and Blood Institute., July 1, 2011.
- [16] Biosensor Technology: Advantages and Applications., <https://www.azosensors.com/article.aspx?ArticleID=402>, (accessed Mar. 20, 2022).

- [17] V. N. a. N. Lee, A review on biosensors and recent development of nanostructured materials-enabled biosensors, *Sensors* (Switzerland), Vols. vol. 21, no. 4, pp, pp. 1-35 doi: 10.3390/s21041109, 2021.
- [18] DIY Arduino pH Meter using Gravity pH Sensor., <https://circuitdigest.com/microcontroller-projects/arduino-ph-meter>, (accessed Mar. 20, 2022).
- [19] Maxim Integrated, *Application Note 6845 Guidelines for Spo2 Measurement Using the Maxim ® Max32664 Sensor Hub*., vol. <https://www.maximintegrated.com/en/an6845>, pp. 1-15, 2014.
- [20] L. Datasheet, in "LM35 Precision centigrade temperature sensors, Retrieved Sept. 13th, [Online]. Available: <https://www.ti.com/lit/ds/symlink/lm35.pdf>, 2017, pp. 1-13.
- [21] Challenges in biosensor development: Detection limit, detection time, and specificity — Experts@Minnesota., in <https://experts.umn.edu/en/publications/challenges-in-biosensor-development-detection-limit-detection-tim>, (accessed Mar. 20, 2022).
- [22] Nanotechnology and Biosensors Google Books. [https://www.google.it/books/edition/Nanotechnology\\_and\\_Biosensors/0eJgDwAAQBAJ?hl=en&gbpv=1&printsec=frontcover](https://www.google.it/books/edition/Nanotechnology_and_Biosensors/0eJgDwAAQBAJ?hl=en&gbpv=1&printsec=frontcover), (accessed Mar. 20, 2022)..
- [23] D. J. N. a. M. G. B. C. B. Murray, Synthesis and Characterization of Nearly Monodisperse CdE (E = S, Se, Te) Semiconductor Nanocrystallites, *J. Am. Chem. Soc.*, vol. 115, no. 19, pp., 8706–8715, Sep. 1993, doi: 10.1021/JA00072A025.
- [24] Microsoft, Introduction To Microsoft Security Development Lifecycle (SDL) Threat Modeling., Vols. Available: [http://www.cs.berkeley.edu/~daw/teaching/cs261-f12/hws/Introduction\\_to\\_Threat\\_Modeling.pdf](http://www.cs.berkeley.edu/~daw/teaching/cs261-f12/hws/Introduction_to_Threat_Modeling.pdf) [https://people.eecs.berkeley.edu/~daw/teaching/cs261-f12/hws/Introduction\\_to\\_Threat\\_Modeling.pdf](https://people.eecs.berkeley.edu/~daw/teaching/cs261-f12/hws/Introduction_to_Threat_Modeling.pdf) <http://download.microsoft.com/download/9/3/5/9355>, p. 77, 2012.
- [25] NIST Cybersecurity Framework Team, Framework for Improving Critical Infrastructure Cybersecurity, *Proc. Annu. ISA Anal. Div. Symp.*, Vols. vol. 535., no. [Online]. Available: <https://nvlpubs.nist.gov/nistpubs/CSWP/NIST.CSWP.04162018.pdf>, pp. 9–25, 2018.
- [26] [https://www.researchgate.net/publication/374199112\\_Heart\\_beat\\_sensor\\_simulation\\_in\\_proteus\\_for\\_beginner\\_part1](https://www.researchgate.net/publication/374199112_Heart_beat_sensor_simulation_in_proteus_for_beginner_part1).
- [27] [interfacing-lm35-arduino-proteus-isis.html](http://www.theengineeringprojects.com), /www.theengineeringprojects.com, 2015/09.
- [28] ATmega328P, [www.microchip.com](http://www.microchip.com), <https://www.microchip.com/en-us/product/ATmega328P>.
- [29] [arduino-uno-library-for-proteus-v2](http://www.theengineeringprojects.com), [www.theengineeringprojects.com](http://www.theengineeringprojects.com), 2021/03.
- [30] esp8266, <https://www.espressif.com/en/products/socs/esp8266>, 2021.
- [31] Analytical chemistry, "in *The new waves of Ion-selectives*, August 1. 2002, p. 422 A.
- [32] R. P. Buck and Lindner, in *E. Anal. Chem*, 2001, pp. 73, 88 A–97 A.

[33] E. Bakker, P. Bühlmann and Pretsch, E. Chem. Rev., 1997, p. 3083–3132..

[34] zimmerpeacocktech, electrochemical-sensors, <https://www.zimmerpeacocktech.com/products/electrochemical-sensors/ph-sensor/>.