

POLITECNICO DI TORINO

Master Degree Course
Management engineering

Graduation Thesis

Artificial intelligence tools in support of product development.



Supervisors

Prof.ssa Francesca Montagna
Prof. Gaetano Cascini

Candidate

Andrea Loi

Academic Year 2022–2023

July 2023 Session

Sommario

Introduction	7
1 Product development process overview:	9
1.1 The critical importance of individual team members in Product Development:.....	10
1.2 Product development model:.....	11
1.2.1 Product development types:.....	12
1.2.2 Planning:.....	16
1.2.3 Concept development:	36
1.2.4 System level design:	53
1.2.5 Detailed design:	57
1.2.6 Prototyping:	60
1.2.7 Design for manufacturing (DFM):.....	60
1.2.8 Product review:.....	68
2 Artificial intelligence overview:	71
2.1 Machine Learning	72
2.1.1 Supervised Learning.....	73
2.1.2 Unsupervised Learning.....	74
2.1.3 Reinforcement Learning.....	75
2.1.4 Deep Learning	76
2.1.5 Generative Models: Generative Adversarial Networks (GANs) and Variational Autoencoders (VAEs)	78
2.3 Evolutionary Computation	78
2.3.1 Genetic Algorithms.....	78
2.4 Computer Vision	79
2.4.1 Object recognition	80
2.4.2 Image Understanding.....	80
2.5 Robotics	80
2.5.1 Intelligent Control	80
2.5.2 Autonomous Exploration.....	81
2.6 Expert Systems.....	81
2.6.1 Decision Support Systems	81
2.6.2 Teaching Systems	82
2.7 Speech Processing.....	82
2.7.1 Speech Recognition.....	82
2.7.2 Speech Synthesis.....	82

2.7.3 Speaker Identification.....	83
2.8 Natural Language Processing.....	83
2.9 Planning.....	84
2.9.1 Scheduling.....	85
2.10 Large Language Models.....	85
3 AI-supported decision-making processes in product development:.....	86
3.1 CoA in Product development process model:.....	89
3.1.1 Identification:.....	89
3.1.2 Structuring:.....	90
3.1.3 Control:.....	91
3.1.4 Development:.....	92
3.2 A.I. in Context of Actions:.....	93
3.2.1 Multifaceted Landscape of Artificial Intelligence: Branches, Models, Algorithms. 93	
3.2.2 Association between branches and CoA:.....	94
3.3 Bridging A.I. and Product development through CoA:.....	95
3.4 Examples of Commercial Software.....	96
3.4.1 MarketSim.....	96
3.4.2 IBM Watson Studio.....	97
3.4.3 Hootsuite Insights.....	98
3.4.4 Crayon.....	100
3.4.5 Brandwatch.....	101
3.4.6 Tara AI.....	102
3.4.7 Tableau.....	103
3.4.8 Synera.....	104
3.4.9 Fusion360.....	108
3.4.10 Midjourney.....	111
3.4.11 DALL-E.....	113
3.4.12 Dezgo.....	114
3.4.13 ANSYS.....	115
3.4.14 GE Digital's Predix.....	116
3.4.15 Simcenter Amesim.....	118
3.4.16 Value Chain 2.0.....	119
3.4.17 Jaggaer.....	120
3.4.18 GPT-4.....	121

4	Augmentation, support and automation of product development activities with AI:	125
4.1	Generative design:.....	127
4.1.1	Image generation:.....	127
4.1.2	3D model generation:.....	129
4.2	Optimization:.....	131
4.2.1	Topology optimization:.....	131
4.2.2	General feature optimization:	132
4.2.3	Material properties optimization:	134
4.2.4	Resources allocation optimization:.....	134
4.3	Data Analysis:.....	136
4.3.1	Explanation AI models for customer segmentation:.....	136
4.3.2	Opportunity suggestion based on data survey:.....	136
4.4	Data gathering:	137
4.4.1	Custom survey generation:.....	138
4.4.2	BoM missing features auto-update:.....	139
4.5	Communication assistance:.....	140
4.5.1	Augmented reality:.....	140
5	Conclusions:.....	143
6	Bibliography/sitography	145

Introduction

The significance of Artificial Intelligence (AI) from an economic perspective is rapidly escalating. Investments across all industries have seen a significant surge, particularly in the last five years. This surge is largely attributable to the advancements in the technology that underpin the application of AI. These advancements are reflected in the increasing number of AI-related patents, indicating a vibrant and growing field of innovation.

The economic impact of AI is substantial. As of 2021, US and global private investment in AI totaled \$53bn and \$94bn respectively, each up more than fivefold in real terms from five years prior [36]. If investment continues to increase at the more modest pace that software investment grew at during the 1990s, US investment in AI alone could approach 1% of US GDP by 2030.

Globally a similar result can be found with an average growth rate of 47% and a CAGR of 46%.

The growth of AI-related patents is also noteworthy. AI patents have been on the rise worldwide, with a 70% average yearly growth rate and a 77% CAGR between 2015 and 2021, which is higher than the annual growth rate observed for other patents. This growth is a clear indication of the increasing innovation and application of AI across various sectors.

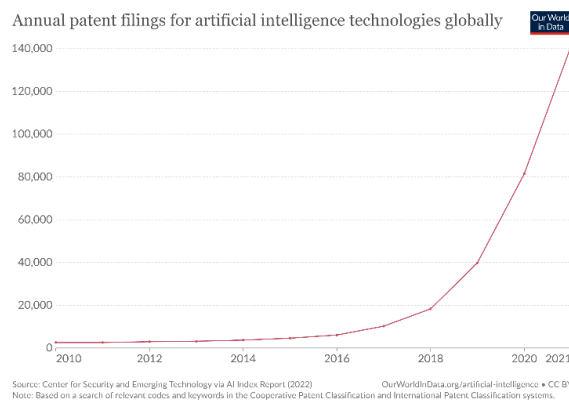
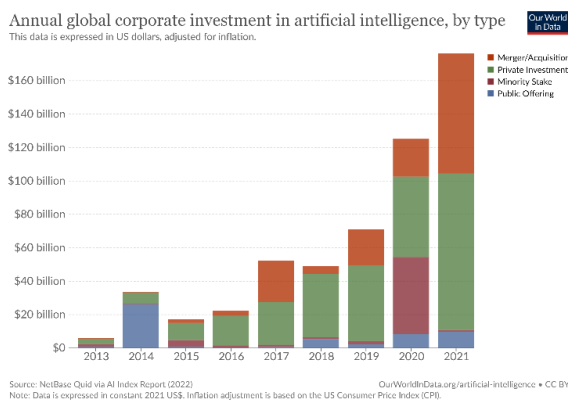

The implications of this growth are far-reaching, leading to a shift in the demand for capabilities across all industries. Industries such as advanced electronics, semiconductors, automotive assembly, banking, healthcare, and retail are among those most impacted by the diffusion of AI. This shift is not only changing the nature of jobs but also creating new opportunities and challenges in the labor market.

According to McKinsey Global Institute [44], only about 20 percent of AI-aware firms are using one or more of the technologies in a core business process or at scale. However, the potential value to be harnessed provides a clear incentive for technology developers, companies, policy-makers, and users to try to tackle these issues. The limitations of AI, including the requirements around the volume, type, and labeling of data, regulatory obstacles, and social and user acceptance, are being addressed by evolving technologies, promising a future where AI is more integrated into our work flows.

In this rapidly evolving scenario, there is ample room for studying the application of AI in the context of product development. AI can be applied in various activities of product development, from initial design to final production, enhancing efficiency, reducing costs, and improving product quality.

This thesis is structured into four chapters, each addressing a different aspect of AI in product development:

Chapter 1 proposes a product development model primarily based on Ulrich and Eppinger. The focus in this part is about the actual tools and problems that characterize each phase of the model.

Chapter 2 provides a brief introduction to the different branches and functioning principles of AI. This chapter aims to familiarize the reader with the various aspects of AI and introduce its functioning principles.

Chapter 3 presents the logic behind the construction of a comprehensive framework that associates AI branches, models, and algorithms to each phase of product development. This logic is based on the utilization of the Context of Actions. A list of possible commercial solutions is also provided as a reference of real AI tools used in the product development.

Chapter 4 focuses on real and theoretical applications of AI in particular stages of the product development model, considered in the light of its implications towards the process used to conclude different tasks. These applications are categorized into three types: support, augmentation, and automation.

Each chapter contributes to a comprehensive understanding of the role of AI in product development, providing insights that are valuable for both academia and industry. This thesis aims to bridge the gap between the theoretical understanding of AI and its practical application in product development, shedding light on the potential of AI to revolutionize this field.

1 Product development process overview:

Product development is a complex set of interdisciplinary activities that draw on information, methods and perspectives from different fields of knowledge. From the use of neuroscience and psychology in marketing and internal resource management, to the implications of materials science and numerical calculation in the engineering and design of components and whole production systems.

Broadly speaking, the three areas most involved in a product development process are marketing, design/engineering and production, each with specific objectives and procedures that must take into account those of the others in order to work harmoniously and produce a successful product.

A product is successful when it simultaneously delivers a level of quality and perceived usefulness/satisfaction to the target customer that justifies the price at which it is sold. At the same time, it must be economically stable, i.e. it must be able to cover the costs of production, distribution, manufacturing and design costs as low as possible. Finally, it must be brought to market in time to be competitive with the competition.

Whatever the priority objective, it is essential that the interaction and communication between the product and the customer must meet the customer's expected or, better still, latent expectations. Therefore, the basic condition for addressing this issue is the actual existence of a group of customers who take into account this unsatisfied expectation. Without this element, no product can be successful, neither for individual consumers (B2C) nor for entire companies (B2B). This dissatisfaction represents an opportunity that marketing must first calibrate on the basis of the company's own characteristics and resources, combined with a careful study of the environment.

Once these premises have been met, the equally important problem is to define, design and manufacture a product whose functionality guarantees the following expectations of the target customers, even if they are unaware of these expectations and are not yet fully prepared to accept the technological change associated with the product being manufactured. This is where the responsibilities of designers and engineers come into play designers, who must be able to do this within the limits of what the company that the company can offer in terms of human, immaterial and material resources. Examples of these actual capabilities entitled to the disposable human resources, the existence of patents or possible licences that can guarantee protection in the circumstances of the use of one or more specific technologies, and the machinery (from lathes to the robotic workstations) that the company can activate. There are also external constraints that can often create opportunities, such as legal and/or regulatory constraints linked to the enactment of laws that of a product category from a market or impose certain standards on basic component categories.

In addition, except in the very special case of start-ups that may drastically revolutionise the way certain customers approach certain products or exploit disruptive technologies, all of this must be done in the context of the economic constraint of the sustainability of the cost of realising that product. This is focused on those areas that are more cross-functional and less related to the product development process in the traditional sense, such as project portfolio management teams and budget reviewers.

Nevertheless, any product development project, especially one that lasts several years, must take into account the trend and the deviation of costs and schedules from the planned one, in order to be aware of the underlying financial reality as early as possible, so as to be able to direct the allocation of resources, not only in monetary terms, in the most favorable direction in the event of unpredictable scenarios.

In line with this philosophy, but in a different sense, the constant monitoring of the competition, in terms of products launched, internal changes in resources, development costs and the dynamics of economic indicators such as sales, the degree of awareness of the common market objective and the percentage of acceptance of the same, is an essential element in ensuring the effective management of the entire process.

From this brief introduction, it is clear that non-linearity, complexity and the convergence of diametrically opposed elements are attributes that characterise any product development process, from the seemingly banal implementation of a new product version/range to be juxtaposed with a series of existing ones, to the reproduction of a product linked to fundamentally unexplored technologies and aimed at uncertain, if not non-existent, markets.

1.1 The critical importance of individual team members in Product Development:

In the realm of product development, the role of technology and systems may be vast, but they are never complete without the human element - the team member. The core of every innovative, successful product lies not in machinery or software, but in the hearts and minds of the people who create them. Each team member brings a unique set of skills, perspectives, and experiences that can turn an ordinary concept into an extraordinary product.

Human team members serve as the primary drivers of creativity and innovation in product development. They generate new ideas, challenge existing ones, and strive to solve problems in ways that no machine or algorithm can. Their intuition, empathy, and understanding of customer needs are invaluable in creating products that truly resonate with the target market.

Additionally, they can adapt and react to unexpected changes or challenges that arise in the course of product development. This kind of flexibility and problem-solving prowess is something that automated processes can't quite replicate.

Moreover, team members bring emotional intelligence to the table. They are the ones who can foster a collaborative environment, navigate conflicts, and inspire each other to perform at their best. This kind of team dynamic contributes immensely to the overall success of the product development process.

Therefore, while technology and systems play significant roles in product development, the human element is undeniably crucial. Recognizing the importance of every team member in the process not only creates better products but also cultivates a more productive and rewarding work environment. The choice of team members is crucial to the success of the project. A team made up of competent professionals who are able to work together effectively, taking advantage of their mutual complementarities, is more likely to achieve the desired results than a team in which individual skills are inferior and/or members do not work well together. Team members should conduct a thorough analysis of each individual's unique attributes and skillsets, while also assessing the extent of diversity present within the group.

In general, the relationship between team diversity and performance follows an inverted U-shaped curve. A certain level of diversity adds richness to internal debate and the ability to generate new ideas, but at a certain point the difficulty of communicating and understanding each other begins to predominate. There are a number of dimensions that need to be assessed in the allocation process. The most important dimension is the match between the requirements of the project activities and the individual professional competences. This first dimension is relatively easy to assess, as it is generally possible to access or generate data on the competences of the technical staff, while others are more delicate. These dimensions include:

- **Personal characteristics:** Ex. Degree of openness, optimism, ability to work in a team and diversity. A team of pessimistic members will only explore the most conservative technical solutions, whereas a team of optimists may propose solutions without sufficiently exploring their risks.
- **Gender:** Men and women involved in innovative activities approach technical problems from different perspectives and with slightly different cognitive approaches. Therefore, diversity in team composition enriches the innovation process and leads to better results.
- **Experience:** Novice and experienced designers approach technical problems in different ways. The former are more methodical and use a predefined process as a problem-solving strategy to compensate for their lack of experience. The process is well structured and documented, starting with a thorough clarification of the problem, followed by the proposal and analysis of potential solutions. In contrast, experienced designers tend to rely on intuition and experience and follow a less structured and documented but faster process.
- **National culture:** It influences the way people work in organisations and deal with the problems of their profession. There are five 'cultural dimensions' that define national cultures:
 - **"Power distance" vs. "equalitarianism":** Degree of acceptance of inequality of power and wealth.
 - **Individualism vs. collectivism.**
 - **Uncertainty avoidance vs. risk taking.**
 - **Long-term vs. short-term.**
 - **National culture:** influences behaviour and approaches to dealing with problems. In addition, people's national culture will lead to diversity in international teams, with the implications for prosperity and coordination problems that need to be addressed. Furthermore, with globalisation, many knowledge workers have had the opportunity to study and work abroad, which is likely to reduce the influence of the national culture of their home country.

1.2 Product development model:

The main model to which reference will be made is that of Ulrich and Eppinger (Activity based model), in Product Design and Development [R] which focuses on those typically physical products.

Some examples from Pahl, Beitz, Feldhusen and Grote will also be considered, particularly for the more engineering phases.

Product development processes will be considered that are predominantly characteristic of B2C markets, i.e. those where the final recipient of the product is the end consumer and not an intermediary between him and the company producing the product. The difference with B2B is not so much in the order of the activities, but in the manner and approach in which they are carried out.

In the broad landscape of commerce, the arenas of B2C and B2B may seem distinct, yet they share a common thread - the customer. The type of customer, be it an individual consumer or an organization, shapes the nature of business and inevitably, the processes of product development.

1. **The Customer Base:** It is a tale of two scales. B2C businesses interact with a sprawling network of individual customers, each making purchases of smaller volume, whilst B2B entities deal with a tighter knit of customers who, however, are prone to procuring in larger volumes. These varying scales bring about a noticeable influence on the scope and magnitude of the product development solutions created.
2. **Catering to Customer Needs:** In the realm of B2C, products are conceived and nurtured to meet personal desires and tastes, shedding light on aesthetics, convenience, and user experience. B2B products, in contrast, rise from the necessity to solve complex business quandaries and are bred to emphasize aspects such as efficiency, productivity, and investment returns.
3. **Decision-Making Journey:** The journey from consideration to purchase is personal and often solitary in B2C, guided by the compass of personal preferences, price, and brand perception. In the B2B world, the expedition is typically a group effort, navigating the complex terrains of long-term value, compatibility with existing infrastructure, and continuous service and support.
4. **The Complexity of Products:** B2B products often carry a higher degree of complexity (an exception being the automotive industry), needing to marry into the broader family of existing business systems and processes. This inevitably translates into a more meticulous and elongated product development journey with a keen focus on customization and scalability.
5. **The Sales Cycle:** Time is another factor that distinguishes these sectors. The B2B sales cycle often outstretches the B2C's, impacting the tempo of product development and ushering in the need for more thorough after-sales service and support.

Each sector, be it B2C or B2B, necessitates its unique tools and methodologies for product development, designed to produce, utilize, and model a specific set of objects. Although an array of methods and tools exist, the focus remains on those tailored to serve specific contexts, products, and approaches that vary significantly in their nature.

1.2.1 Product development types:

The inherent complexity of product development necessarily leads to the configuration of different families/classes, characterised by the greater importance of some phases/activities than others. Nevertheless, there is a basic/fundamental process whose modification allows each of the families/classes to be defined:

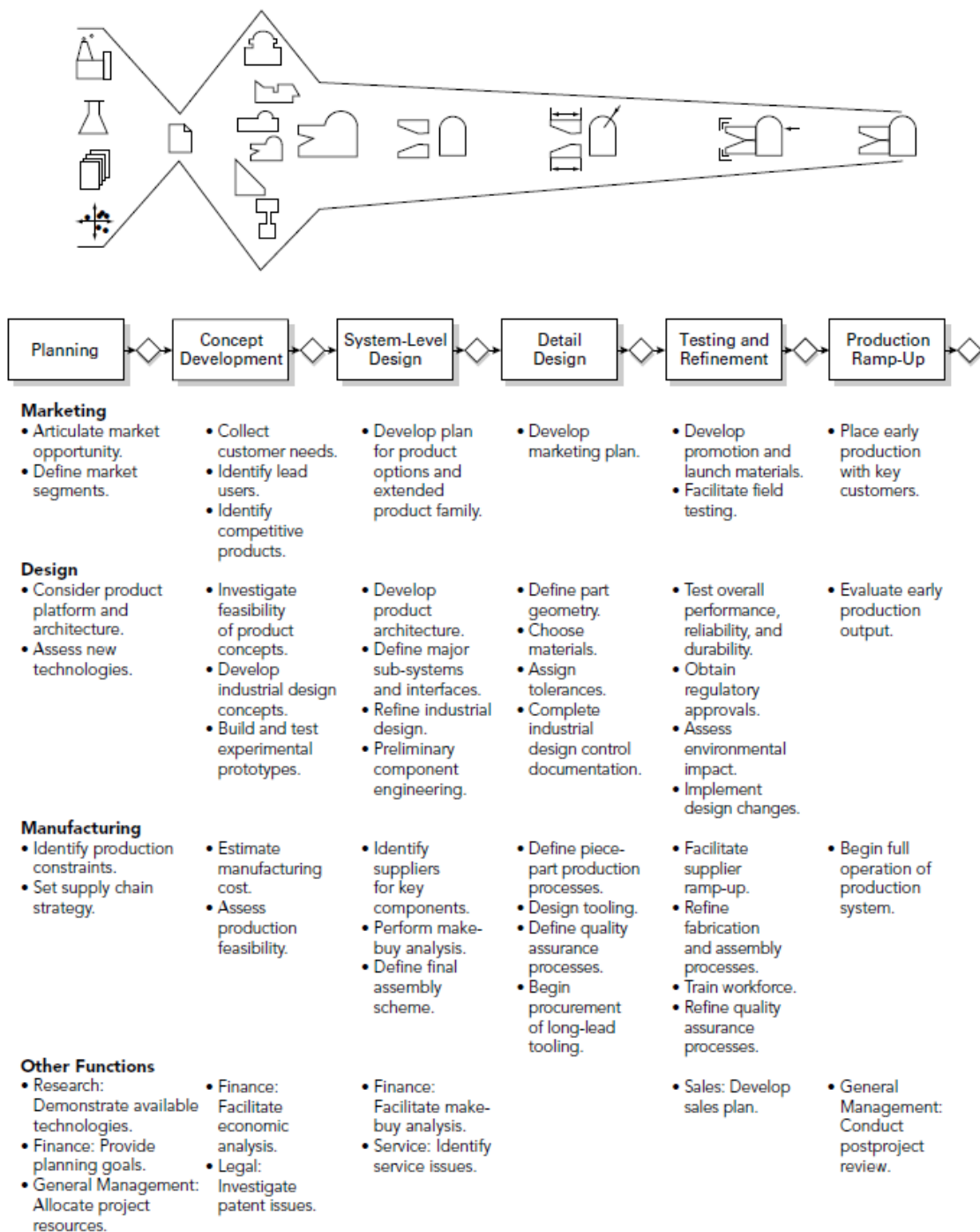

Figure 1 The generic product development process [25]

Technology Push and Market Pull, but not the only ones, as will be seen below, are the two main elements that go on to define the type of product development process that is established in a more effective way.

The first reflects all the impulses that come from the R&D departments and is therefore more focused on the nature of the medium that underpins the functioning of a product and is independent of the specific needs of the market, while the second is more concerned with the way in which this product must interface with the customer, whose satisfaction is the sole objective.

In other words, on the one hand, the availability of a new technology "pushes" the creation of products that use that technology, and on the other hand, market demand or customer demand "pulls" or influences the development of new products.

The predominance of one over the other also leads to differences in other factors, the most important of which are summarised in the table below.

Description	Technology push	Market pull
Technology uncertainty	High	Low
R&D expenses High Low	High	Low
R&D duration Long Short	Long	Short
R&D customer integration	Difficult	Easy
Time-to-market	Uncertain/unknown	Certain/known
Sales market-related uncertainty	High	Low
Kinds of market research	Qualitative-discovering	Quantitative- verifying
Need for change of customer Behavior	Extensive	Minimal

Table 1 Comparison table [16]

Technology push	Market pull
Risk of starting with what can be researched and evaluated easily	Risk of looking only at needs that are easily identified but with minor potential
Risk of addressing the needs of atypical user	Continuing to change the definition of the "opportunity"; "miss the opportunity"
Potential for getting locked into one technical solution	Lack of being a "champion" or "true believer"

Table 2 Risk comparison [16]

Other factors that influence, but are somewhat related to the two previously discussed, are related to the degree of inherent complexity of the product, the logic of launching and differentiating the product or not, or its timing.

Process Type	Description	Distinct Features	Examples
Generic (Market-Pull) Products	The team begins with a market opportunity and selects appropriate technologies to meet customer needs.	Process generally includes distinct planning, concept development, system-level design, detail design, testing and refinement, and production ramp-up phases.	Sporting goods, furniture, tools.
Technology-Push Products	The team begins with a new technology, then finds an appropriate market.	Planning phase involves matching technology and market. Concept development assumes a given technology.	Gore-Tex rainwear, Tyvek envelopes.
Platform Products	The team assumes that the new product will be built around an established technological subsystem.	Concept development assumes a proven technology platform.	Consumer electronics, computers, printers.
Process-Intensive Products	Characteristics of the product are highly constrained by the production process.	Either an existing production process must be specified from the start, or both product and process must be developed together from the start.	Snack foods, breakfast cereals, chemicals, semiconductors.
Customized Products	New products are slight variations of existing configurations.	Similarity of projects allows for a streamlined and highly structured development process.	Motors, switches, batteries, containers.
High-Risk Products	Technical or market uncertainties create high risks of failure.	Risks are identified early and tracked throughout the process. Analysis and testing activities take place as early as possible.	Pharmaceuticals, space systems.
Quick-Build Products	Rapid modeling and prototyping enables many design-build-test cycles.	Detail design and testing phases are repeated a number of times until the product is completed or time/budget runs out.	Software, cellular phones.
Complex Systems	System must be decomposed into several subsystems and many components.	Subsystems and components are developed by many teams working in parallel, followed by system integration and validation.	Airplanes, jet engines, automobiles.

Figure 2 Summary of variants of generic product development process. [25]

The two variants that differ the most in terms of activity scheduling are Quick-Build Products (or Spiral Products) and Complex Systems.

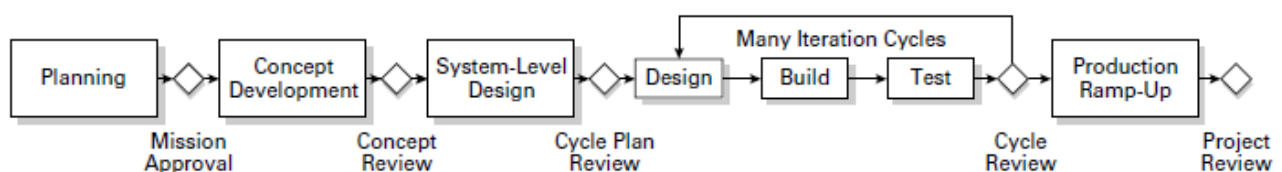

Figure 3 Quick Build/Spiral Product Development Process [25]

Quick Build Products (Spiral Product Development): This type of product development is characterized by rapid prototyping and iterative testing.

An example in the automotive industry could be the development of a new infotainment system for a car. The team would start with a basic prototype, test it, gather feedback, and then make improvements in a series of iterations. This allows for quick adjustments and improvements based on real-world feedback.

This is also the typical approach of start-ups, which create various minimum viable products (MVPs) that allow them to simultaneously test the actual interest from the target market niches and the actual functioning against the planned results.

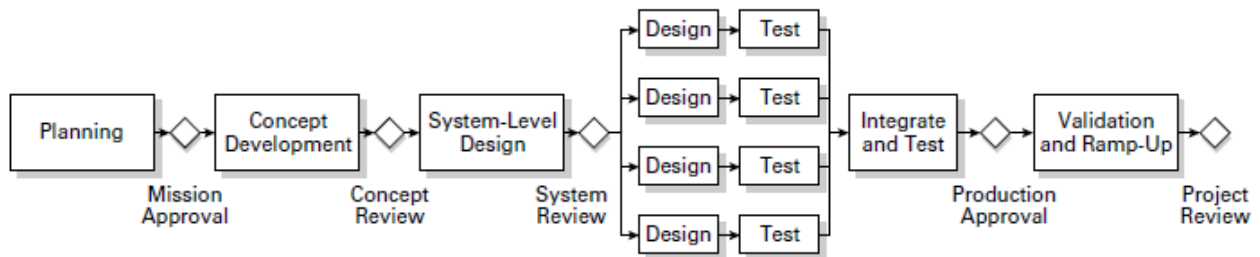

Figure 4 Complex System Development Process [25]

Complex Systems: They are characterised by a large number of intricately interacting components. Groups of components define a subsystem which, in itself, may function according to the expected results, but which, taken as a whole in the architecture of a product, may produce unwanted consequences.

An example in the automotive industry could be the development of a new hybrid or electric powertrain system. This would involve the integration of various components such as the electric motor, battery, control systems, and possibly a combustion engine. This type of development requires careful planning, coordination, and testing to ensure all components work together seamlessly, considering the most apparently unpredictable situation.

If not taken seriously, this type of thoughtlessness can lead to catastrophic consequences in both economic term and consumer trust.

For instance, In 2018, Tesla had to recall 123,000 Model S vehicles due to power steering issues related to a software glitch [1] and in 2011, after a crash test by the National Highway Traffic Safety Administration (NHTSA), a Chevy Volt caught fire three weeks after the test due to damage to the battery pack [2].

1.2.2 Planning:

It is the most strategic phase in which the definition and structuring of the context and environment associated to the product development process have a significant role. For the success of the planning phase, it is therefore essential to find and process as much useful information as possible in order to reduce the uncertainty of the context on which the product development process itself is based.

Referring to the decision-making process defined by Mintzberg in “The structure of unstructured decision processes” [51] therefore the focus would be in the first part of the

model, where the process of *identification* takes space. This is also shown in paragraph 3.1, where the Context of Action of Identification is better analyzed in the entire product development process. It is also important to clarify that although the identification process is the most relevant, also the decision process of *development* and *selection* take place during this phase, in particular in the opportunity generation, selection, evaluation of projects and scheduling.

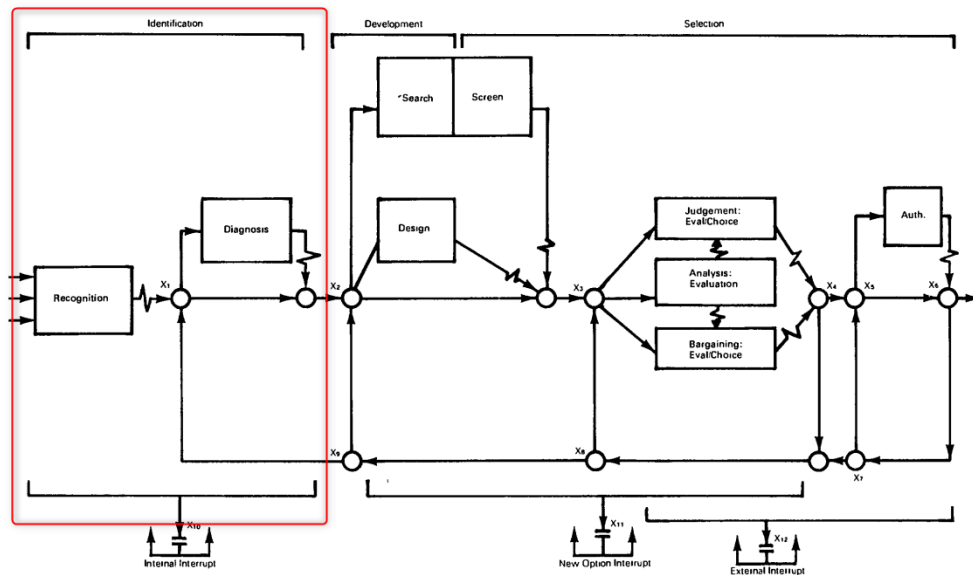

Figure 5 Mintzberg's decision process diagram

Since the first part of the decision making process is the one that characterizes the most the planning phase, the principal class of decision aiding process is surely *Action structuring*. This can be particularly helpful in unstructured context, where no alternative neither objective are defined and thus there is no real definition of an effective set of actions to consider for the execution of the activity of this phase and the others.

The data necessary to conduct this activity can come both from within the organization itself (the most important of which are those of this type), e.g. linked to the results of previous products developed, and from outside, e.g. how other organizations have approached the development of similar products. The outcome of this will effectively determine the initial information base on which all other subsequent phases will depend.

The main purposes for which this information is processed are:

1. Acquire a technology/market strategy and a consequent first action plan in terms of TTM, schedule of specific activities and resources.
2. Generate and evaluate product ideas and opportunities.
3. Identify and structure the needs of customers representative of the reference market segments and define an initial price range for the product.

The processing of the information/data initially takes the form of the development of several opportunities, which can be defined as generic descriptions of an embryonic product or family of products incorporating a new technology so as to allow, as a first approximation, a match between a market need, not necessarily existing, and a technical solution based on this technology. At the same time, all opportunities are classified according to the organization's

level of technological and market knowledge, understood as the familiarity of the development teams with the solution identified and with the needs to be addressed.

In fact, an immature form of product portfolio is created, which is potentially taken into account in the following phases and which is progressively narrowed down with the increase of available information and with the succession of in-depth studies both on the technical side (mainly from the results of tests on prototypes) and on the market side (from surveys, analysis of the product in use...).

In this respect, the central phase of the design is that of identifying the various needs perceived by the market and transforming them into functional requirements, i.e. non-technical but measurable interpretations of what the customer expects from the product. The latter is used as a reference for the design and engineering phase as an abstract objective of what the product will tend to do. This particular phase is particularly at the crossroads between planning and conceptual design and is always characterised by repetition, since it is difficult to capture all the needs, especially the latent ones, in a single session of observation or distribution of questionnaires, or to define immediately a functional requirement linked to a very abstract need.

A product plan is then identified and initialised, which characterises the portfolio of products to be created, defining the expected launch dates, the categories of products to be created, the discounted value of each portfolio project and other design characteristics. This plan should take into account the amount and type of resources, both human and non-human, that are expected to be used and the specific activities that are expected to be undertaken.

Irrespective of the specific case, a dynamic of progressive selection is established, typical of funnel models, where as the information base grows, and with it the sequence of activities, the initial ideas are gradually skimmed off until only a fraction of them are actually taken into account in the subsequent stages.

Ulrich and Eppinger describe this process by comparing it to what happens in a tournament.

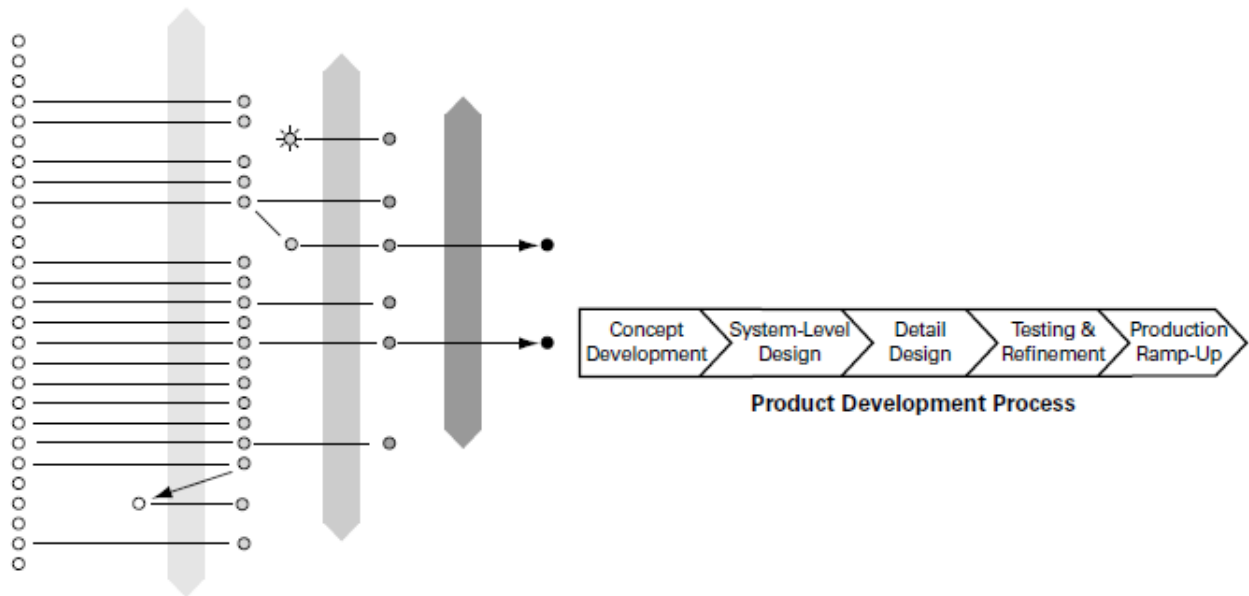

Figure 6 The tournament structure of the opportunity identification process [25]

Finally, it should be emphasised that the stages suggested here are not to be understood in a sequential sense. The screening of opportunities, the correction of microscopic/elementary activities and the associated external and internal resources to be loaded, as well as the collection and interpretation of needs, are all activities that exchange information and condition each other. At the same time, the activities that make up planning do not take place in isolation from those of concept development or from those that follow.

1.2.2.1 Opportunity analysis:

This is the more strategic activity, where the vision of the product development process is broadly defined and an attempt is made to justify from a high level perspective why it makes sense to focus on a particular market and use a particular technology. It is a phase in which we try to define the fundamental elements that characterise the environment in which we want to start the process and that relate to the organisation itself.

1. **General environment data gathering:** Ulrich and Eppinger do not explicitly define this activity as it is not really separable from opportunity generation, opportunity development or even the tasks that characterise product planning in general. The distinction is made in order to emphasise that the implementation of an effective product development process requires an initial analysis and data collection of a more strategic nature, to which reference can be made in order to direct the energies and reasoning that lead to the generation of opportunities, if not directly to concepts. In fact, at this stage there is a great deal of uncertainty regarding the reaction of customer types, industry players, competitors themselves and the emergence of regulatory constraints or entirely new technologies, and a first way of reducing this uncertainty is to carry out a high-level analysis that allows the organisation and its products to be positioned within technological and market variables.
 - **Technological variables:** These are the technological factors that can influence the development of a new product. They include the current state of the art, the availability of technological resources, the level of technological expertise and the potential for technological innovation.

- **Market variables:** These refer to the market factors that may influence the development of a new product. They include customer needs and preferences, market trends, the competitive landscape and complementary products informations.
- **Legal and regulatory variables:** These are also relevant elements for the analysis as they can heavily impact the final design of the product, the production process and also the ancillary processes for certification of the product.

All these types of variables have to be considered and identified by the organization, as in this phase the general environment related to the product idea, defined by all these variables, is not predefined, therefore to frame an effective initial strategy or at least a vision of the product is necessary to gather all this kind of data. The data that can be traced back to these variables come from various sources: patent databases, specific manuals for a product category, academic articles of a more applied nature, internal reports/databases relating to past products, specific technical journals, opinions of technology experts, market reports offered by third parties, feedback from customers already served, interviews with market experts, post-launch analysis of past products, questionnaire response datasets...

The problem is not so much to define the possible sources, but rather to collect useful data (which is extremely difficult when developing products based on completely new technologies) and to find ways of structuring them to be able to consider the strategy that can guide the product development process.

It is emphasised that the main source of data from which to draw inspiration for generating opportunities is within the organisation, in the form of knowledge and expertise that have been accumulated by analysts, engineers and designers in previous projects.

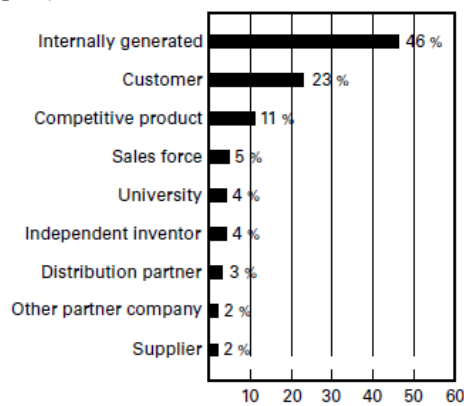

Figure 7 The distribution of sources of opportunities in innovation [25]

Developments in AI have had an impact not only on the automation of data collection and processing, but also on the definition of any patterns within them.

2. **Strategy and innovation charter definition:** In order to support the strategic positioning of the organisation and the product in relation to these variables, there are numerous tools in the literature, of which the model of Porter's 5 Forces, the technological paradigm representations, the SWOT analysis and the PESTEL analysis are some of the main examples.

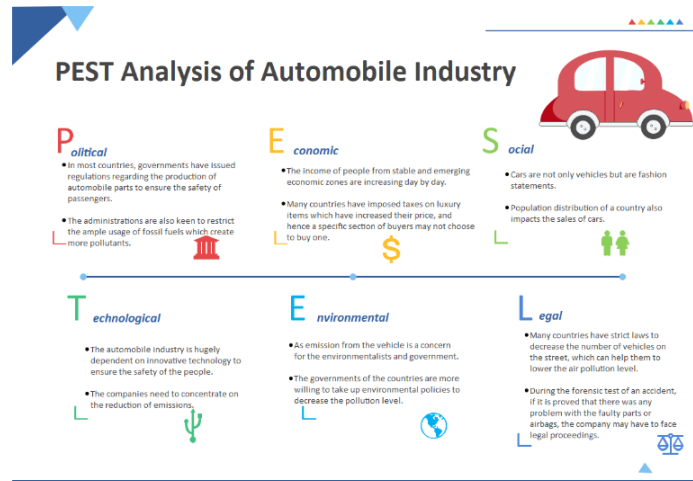

Figure 8 PEST Analysis example

However, the positioning is not self-determined, but a specific choice of the organisation supporting the product, based on the strategy, which in turn is defined based on the processing of the collected market data and technology. A non-exhaustive set of possible strategies, cost leadership in blue, differentiation in yellow, that can be considered once the collected data has been structured, are considered in the table below:

	Industry-wide cost leadership	Cost leadership in specific market segments	Differentiation	Focused differentiation
Description	Being the lowest-cost producer in the industry	Being able to serve the chosen market segment at the lowest cost	Being able to serve many vertically-differentiated segments, maximizing margins gained in each	Specializing in order to serve a single customer segment or niche
How can it be achieved in the product	<ul style="list-style-type: none"> • Reducing direct cost (e.g., components) • Exploiting economies of scale through modularization/std and spreading out R&D investment over large volumes 	<ul style="list-style-type: none"> • Being able to design products that are "valuable" for the specific needs of the segment • Exploiting economies of scope and spreading out the same R&D investment over products in different segments 	<ul style="list-style-type: none"> • Being able to design products that maximize customer utility at each segment • Exploiting economies of scope and spreading out the same R&D investment over products in different segments 	<ul style="list-style-type: none"> • Focusing design efforts in providing the best offering in the industry, for specific segment
How can it be achieved in the process	<ul style="list-style-type: none"> • Industrialization choices for spreading out production investment over a large volume • Exploiting learning economies 	<ul style="list-style-type: none"> • Developing a low-cost process that is "fine-tuned" to specific products • Industrialization choices for exploiting economies of scope and spreading out production investments over products in different segments 	<ul style="list-style-type: none"> • Design before/contextual to sales or long-term contracts • Exploiting economies of scope and flexibility 	<ul style="list-style-type: none"> • Developing "fine-tuned" process that exactly meets the required performance, at the lowest cost possible

Figure 9 Porter's generic strategies [18]

The innovation charter expresses the product objectives and general constraints, for example in terms of TTM, alignment with corporate strategy or reaching a new customer base. It is the object that primarily defines a vision that is able to broadly

limit the scope of the project, making it possible to effectively identify opportunities. Innovation charters are not rigid and are designed to launch the development process itself, but not to do so.

For example:

“To revolutionize the way people travel by creating a fully autonomous vehicle that delivers unmatched safety and convenience. The project budget must be strictly adhered to, with contingencies in place for unforeseen expenses.”

“To disrupt the automotive industry by pioneering the development of an endothermic engine-powered automobile that optimizes energy use, reduces emissions, and provides performance comparable to the competition.”

3. **Opportunities generation:** In broad terms, an opportunity may be the chance to meet a market need (or interest or want) through a creative combination of resources to deliver superior value (Schumpeter, 1934; Kirzner, 1973; Casson, 1982). It's a gap in the market that a company can fill with a product or service that meets customer needs better than existing solutions. It is often defined as a visual image or brief description of the product idea.

The process of identifying opportunities is therefore closely related to the process of identifying market needs, but it takes into account all the elements of information on which the choice of the most effective strategy is based. It is therefore not independent of strategic positioning, but unlike the latter, it focuses on specific research activities for the product. For example, it takes into account market trends in terms of specific consumer preferences associated with the opportunity and the dynamics with which they approach the purchase.

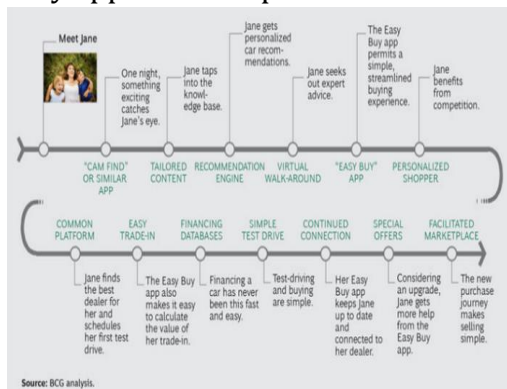

Figure 10 Customer purchase journey [3]

The generation of opportunities is undoubtedly a very little mechanised and regulated process, where at most there are guidelines and heuristics (mainly useful in market pull development processes). Here are proposed three examples of methods to approach the problems of opportunity identification. More exhaustive clarification on the matter can be found in “Opportunity identification: Review, critique and suggested research directions” [10]

Opportunity generation as Creative Insight (Long & amp; , McMullan 1984):

This indicates that opportunity identification is a process which occurs over time instead of in one moment of inspiration. It is a result of a variety of personal, social, technological and cultural forces (PreVision) that result in the perception associated

with a likely market opportunity (Vision). The idea is then assessed as well as refined till the person has an opportunity or not (Elaboration). The Elaboration stage bears the greatest weight within this system.

Opportunity generation as Motivated Search: This method indicates that opportunity identifying is the product of a motivated search procedure. This process is affected by factors including level of aspiration, aptitude, training, skill level, and present job satisfaction or dissatisfaction. This entails trying to find opportunities, locating them, evaluating them and then determining whether to launch the search or go back to the search. This method also entails the environmental context, which includes industrial and social factors. In the search as well as evaluation of opportunities, values, the personality, capabilities as well as accomplishments are taken into consideration. This approach assumes that people are motivated to find jobs and that their motivation might be impacted by their present job satisfaction or dissatisfaction.

Opportunity generation and Perceptual Alertness (Kirzner, 1979, 1985): This suggests that opportunity identification is encountered as a flash of understanding or maybe foresight that is dependent upon the interaction of the right individual with the right circumstance. The "right person" is a person that has entrepreneurial vigilance, referred to as "the ability to recognize with no search opportunities which have been hitherto overlooked" (Kirzner, 1979) or even "a driven propensity of man to develop a picture of the future" (Kirzner, 1985). As a matter of fact, the author thinks that opportunity identification is felt as a flash of understanding or even foresight.

Other more practical techniques are listed below, taken directly from the text by Ulrich and Eppinger [1]:

Technique	Description
Follow a Personal Passion	List your passions and consider how emerging technologies, trends, and business models might influence them and identify unmet needs that you have in connection with a personal interest
Compile Bug Lists	List every annoyance or frustration you encounter over a period of days or weeks and then picking the most universal and vexing ones and dreaming up solutions.
Pull Opportunities from Capabilities	Evaluate your internal resources and consider only the Valuable, Rare, Inimitable and Nonsubstitutable (VRIN). Those resource can generate effective opportunities.
Study Customers	Observe directly customers in a selected market segment, focusing on what the needs that they do not express. The most promising opportunities are based on these needs.
Consider Implications of Trends	List social, environmental, technological, or economic trends and then imagine innovation opportunities made possible by each one.

Imitate, but Better	<p>Analyze solutions developed by successful firms. Consider the development of imitative products that can address the same market or copy-like product that address alternative needs. Examples of data source for imitative opportunity are:</p> <ul style="list-style-type: none"> ➤ <i>Media and marketing activities of other firms</i> ➤ <i>De-commoditize a commodity</i> ➤ <i>Drive an innovation "down market"</i> ➤ <i>Import geographically isolated innovations</i>
Mine Your Sources	<p>Consider the value of external resources from which taking ideas. Examples of this external resources are:</p> <ul style="list-style-type: none"> ➤ <i>Lead users</i> ➤ <i>Representation in social networks</i> ➤ <i>Universities and government laboratories</i> ➤ <i>Online idea submission</i>

For the correct and effective application of the methods, whether they are more abstract or practical, the structuring of the information and data collected on the nature of the market and/or technology on which these methods are based is fundamental. In this case, AI can play an extremely important role, as it is capable of classifying huge amounts of data in a fully automatic way. Indirectly, it can assist in the identification of opportunities in the strict sense, by identifying any gaps in the market once the data has been classified. It follows that it can easily be negatively affected by both the quality of the data and the methods used for training and learning (especially in cases where the supervisors are unaware of the correctness of the indications).

4. **Opportunities review:** For the opportunities screen, which takes the form of a choice between different alternatives, it is essential to confirm and/or further investigate, and thus validate or not, the hypotheses that constitute the basis of those opportunities. The same tools are used in the subsequent phases, such as customer needs identification and concept testing, with the difference that the level of detail in the definition of the product, in terms of specifications and/or functional requirements, is minimal in this context. Here are some practical tools for carrying out this phase:
- **Web based surveys:** This is the most rapid and cost-effective method. From these is possible to collect data to be easily analyze and imported to different statistical software. The main limitations are related to the potential bias of responses if the survey is not well designed and the lack of interaction with the person, which in turn can lead to misinterpretation.
 - **Multivoting work-shop:** Rapid in-person presentations of opportunities coherent to specific themes. These are then put to the vote in such a way that each person's vote does not influence the other's (so they do not all vote simultaneously nor is the judgement of others known before the vote).

In both cases, the fundamental aspect is that the opportunities are submitted to the judgement of a group of experts, who are able to separate personal opinions from those of a more objective nature, and instead consider the actual impact that these opportunities can have on the market.

In addition to the survey components, those that allow the various opportunities to be ranked in terms of relevant variables for assessing the economic risk-benefit of each are also relevant.

The BCG Matrix is one of the tools that can perform this function, focusing on products and their impact on the market from a current and future perspective.

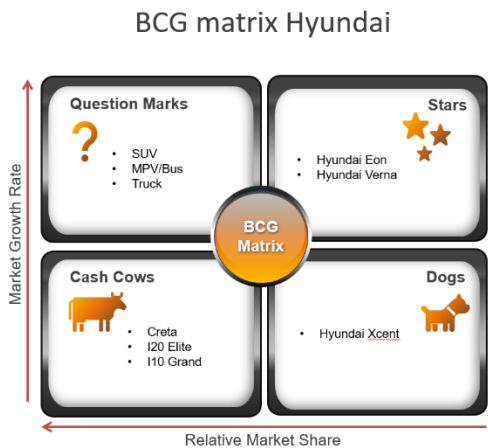

Cash cow: When projects have a low capacity to absorb resources but generate high financial returns, they are called cash cows. **Star:** When projects are expensive in terms of investment but create high returns, they are called star projects. The company invests a lot and they are often innovative technologies, but they have a good market return.

Question mark: Projects in which you have invested a lot, but still do not have a high market return.

Dog: Projects that have not brought in resources, do not bring in money, are not innovative or worthwhile and should be abandoned.

Figure 11 BCG Hyundai

Other tools, such as the McKinsey/GE Matrix and the Ad-little Matrix, try to achieve the same goal by taking

more into account the company's positioning in the market and the impact of the product in the different phases of the life cycle.

Multi-criteria methods, such as the ELECTRE and AHP methods, are also used to guide the choice.

In the case of AHP, a multi-criteria table is used. Criteria are defined using formal criteria construction processes. AHP supports the creation of weights. It compares the criteria and helps to define the weights. A veto threshold is defined, i.e. if it is not reached, they are discarded. Opportunities are entered into the table and prioritised according to the weights and criteria.

5. **Development of promising opportunities:** When the most promising opportunities begin to be developed, the concept development phase begins, in which virtual concepts are created to be tested by carrying out market surveys to assess their potential impact in terms of total and distributed sales over a period of years. In general, activities are carried out to identify and resolve the elements of uncertainty associated with each opportunity, including the presence of patents and trademarks on the market that could prevent their diffusion on the market. The first costing activities are carried out, both in terms of production and in terms of attracting and maintaining market awareness.

The tools used to structure the data are not dissimilar to those previously exposed, but what changes is the quality and reliability of the same, a necessary condition for the operations of comparison and selection of exceptional opportunities.

6. **Selection of exceptional opportunities:** This activity is actually carried out using the tools described in point 3, with the difference that now the degree of uncertainty is reduced to a minimum and the opportunities analysed have already been defined as

promising and, consequently, an amount of capital has already been invested in each of them, making it possible to generate specific data that can be used as a reference for the final choice.

Ulrich and Eppinger propose the Real-Win-Worth-it tool for this specific phase, which can be summarised as follows:

Real-Win-Worth-it (RWW) Framework	Yes/No
<p>1. Is there a real market and a real product?</p> <p>Is there a need? (What is the need? How is the need presently satisfied?)</p> <p>Can the customer buy? (size of the market, customer decision-making process)</p> <p>Will the customer buy? (perceived risks and benefits, expectations on price and availability)</p> <p>Is there a viable concept for a product already? How likely are we to be able to develop a viable concept?</p> <p>Is the product acceptable within the social, legal, and environmental norms?</p> <p>Is the product feasible? Can it be made? Is the technology available? Does it satisfy the needs?</p> <p>Will our product satisfy the market? Is there a relative advantage to other products?</p> <p>Can it be produced at low cost?</p> <p>Are the risks perceived by the customer acceptable? What are the barriers to adoption?</p>	
Final global answer	
<p>2. Can we win? Can our product or service be competitive? Can we succeed as a company?</p> <p>Do we have a competitive advantage? Is it sustainable? (performance, patents, barriers to entry, substitution, price)</p> <p>Is the timing right?</p> <p>Does it fit our brand?</p> <p>Will we beat our competition? (How much will they improve? price trajectories, entrants)</p> <p>Do we have superior resources? (engineering, finance, marketing, production; fit with core competencies)</p> <p>Do we have the management that can win? (experience? fit with culture? commitment to this opportunity?)</p> <p>Do we know the market as well as or better than our competitors? (customer behavior? channels?)</p>	
Final global answer	
<p>3. Is it worth doing? Is the return adequate and the risk acceptable?</p> <p>Will it make money?</p> <p>Do we have the resources and the cash to do this?</p> <p>Are the risks acceptable to us? (What could go wrong? technical risk vs. market risk)</p> <p>Does it fit our strategy? (fit with our growth expectation, impact on brand, embedded options)</p>	
Final global answer	

1.2.2.2 Product planning:

If in the previous phase the focus was on opportunities, now we are starting to talk about product development projects placed within a portfolio. The difference between the two lies in the fact that the former is defined as a qualitative statement (if not in the final stages of opportunity identification), while the latter takes into account in detail the planning of activities, resources needed for the various development projects products that make up a portfolio.

1. **Evaluation and prioritization of projects:** Projects are evaluated in terms of their alignment with the business strategy. Qualitative, quantitative and semi-quantitative tools are used to support this. Semi-quantitative tools are generally of the multi-criteria type. In addition to AHP and ELECTRE, methods such as TOPSIS, VIKOR, PROMETHEE and MAUT or combinations of these methods can be used.

Criteria	Alternatives							
	Unit	Reference year 2020			Reference year 2030			Max/Min
		B	R	P	B	R	P	
Environmental Effectiveness								
Fleet emissions	%	100	94,37	81,2	100	90,57	69,22	Min.
Average Ecoscore	Ecoscore	69,16	69,59	71,65	73,73	73,77	75,43	Max.
Impact on Mobility								
Amount of km driven	%	100	97,46	95,13	100	97,88	90,62	Min.
Modal Choice	Qualitative	1	1	3	1	1	4	Max.
Feasibility								
Financial feasibility	Qualitative	5	3	1	5	3	2	Max.
Technical feasibility	Qualitative	5	4	2	5	4	3	Max.
Socio-political acceptance	Qualitative	5	4	2	5	4	3	Max.

Table 6: PROMETHEE I/II scores

Alternatives	Year	ϕ^+	ϕ^-	ϕ	Rank
Baseline	2020	0.376	0.315	0.061	2
Realistic	2020	0.275	0.402	-0.126	3
Progressive	2020	0.441	0.376	0.066	1
Baseline	2030	0.376	0.371	0.004	2
Realistic	2030	0.320	0.418	-0.098	3
Progressive	2030	0.469	0.376	0.094	1

Figure 12 AHP-PROMETHEE evaluation [14]

As far as strictly quantitative tools are concerned, which in any case take into account numerical variables that are significant for the strategy in terms of economic value and/or time, the most directly applicable tools are those derived from finance, which therefore estimate the NVP of the various projects:

Net Present Value: It is based on discounted cash flows and the NPV is calculated in relation to the investment faced. The drawbacks of this method are:

- It does not take into account the sunk costs that the company has already incurred and from which it could benefit. Think of a company that already has a manufacturing plant or laboratory that it will use for this project, and this element is not included in the NPV.
- It does not take into account what would have happened if things had gone wrong. If they had not made that investment, not only would they probably not have incurred any costs, but they would also have lost any revenue from a customer base that had moved on to another product.

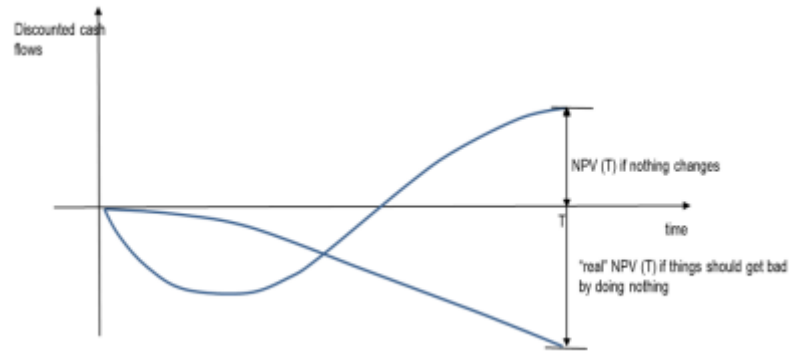

Figure 13 NPV

- **Payback:** The payback time is the time from the start of the investment to the break-even point.

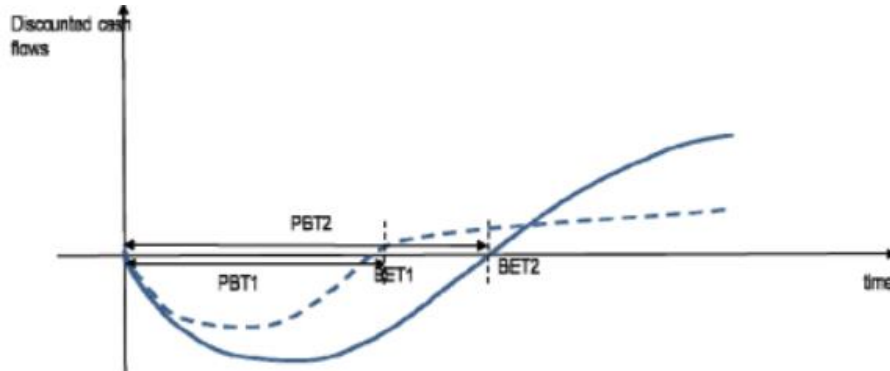

Figure 14 Payback time

Looking at the curve of two different projects

- BET2 has a longer payback period but a higher rate of return. The cash flows are much higher for the same final valuation.
- BET1 has a shorter payback period but a much lower return on investment.

Expected commercial value:

Purely financial methods do not distinguish between the costs associated with the technology and the costs associated with the effort to bring it to market, and these costs are associated with uncertainty in the sense that trials may not be favourable and that there may be market failures. The expected commercial value method is used for this.

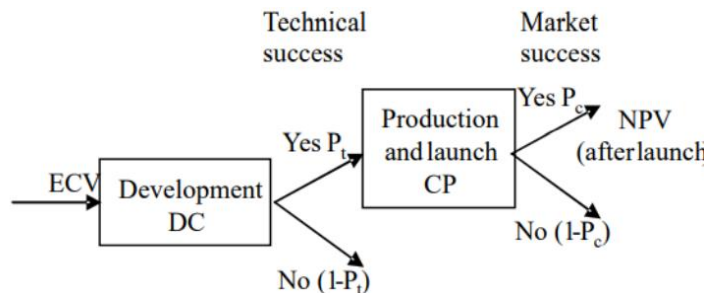

Figure 15 ECV basic graph

Decision tree consisting of the first part represents product development, with associated development costs (DC).

The second part is when product development is completed and the product is launched. This is associated with production and launch costs (CP).

After development, there may be technical success or failure. If there is technical success, the product is produced and launched and production costs are incurred, which can be commercial success or failure.

If the NPV is positive, this is one reason for investing in the second phase, after the product launch. However, the return on investment only happens when market success is achieved, so P_c (market success probability) has to be considered in the final equation. Then it is necessary to remove the production costs CP, that allowed the actual launch of the product.

Finally, this scenario occurs only when the project has been technically successful, therefore P_t (technical success probability) has to be taken in account, and, similarly to what happened previously, the product development costs DC, has to be subtracted to obtain the final Expected commercial value

$$ECV = (NPV \cdot P_c - CP) \cdot P_t - DC$$

The tools proposed here are mostly used as an introduction to a real and complete planning of the different projects occurring during all the product development.

Finally, the tools proposed by Ulrich and Eppinger in the section about product planning are of a more **qualitative** and visually comparative nature and are basically already included in the opportunity identification phase.

However, it should be stressed that the authors do not omit the treatment of variables such as TTM and NVP, but simply postpone them and consider them in a completely cross-cutting activities of economic performance valuation and project management.

2. **Scheduling of project activities and resource allocation:** If a project in the portfolio has been considered valid in terms of NVP, ECV and strategy alinement, A more detailed analysis is carried out, taking into account the resources of all types that will be involved in the process. Make-or-buy decisions and, consequently, constraints on the manufacturing processes to be initiated for the process become more apparent. Of course, since the output proposed here is pre-planning chart (Gantt), these constraints and choices are not fixed, but may evolve as the general situation evolves.

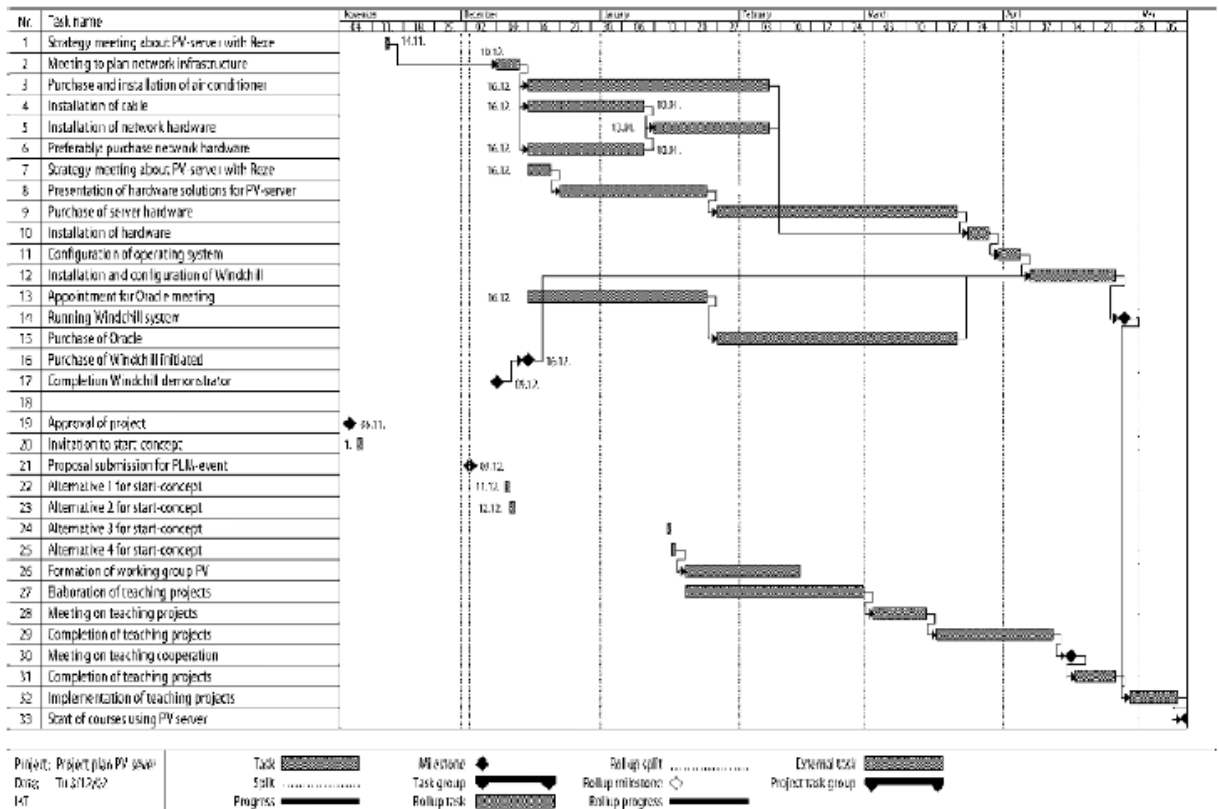

Figure 16 Product development schedule [9]

There are many useful techniques that can help to define a valid product development plan and schedule:

- CPM (critical path method).
- PERT (project evaluation and review technique).
- PDM (precedence diagram method).
- CCM (critical chain method).
- GERT (graphical evaluation and review technique).

Generally, when it comes to resources allocations, heuristics techniques are chosen, with regard to the strategy guiding the project, in order to prioritize activities. For example:

- ROT (resource over time).
- ACTRES (activity resources).
- ACTIM (activity time).

To minimize development time and avoid the occurrence of problems downstream of the process (integration, quality...), in the automotive industry but in many other ones, **concurrent engineering** is used.

Alongside this activity, a more thorough analysis of the real market demand in financial terms should be carried out in order to assess its growth as accurately as possible. It is good practice to consider different scenarios to make the analysis more robust, and even better to use Monte Carlo simulations.

If all these activities have been correctly made, it should be possible to determine:

- Time To Market: The amount of time between the time I launch a product and the time it reaches the market.
- Technology readiness: Necessary time to develop the technology.
- Market readiness: Necessary time for the market to consider the purchase of the product.

3. **Complete pre project planning:** Downstream of these activities, but also in consideration of the identification of customer needs that occurs alongside all the planning phase, Ulrich and Eppinger propose a document, called **Mission statement**, which condenses all the fundamental aspects that characterise the product development process in seven components:

- Product description
- Benefit proposition
- Key business goals
- Primary market
- Secondary market
- Assumptions and constraints
- Stakeholder

Another useful tool for verifying strategy-project alignment is the Technology Roadmap.

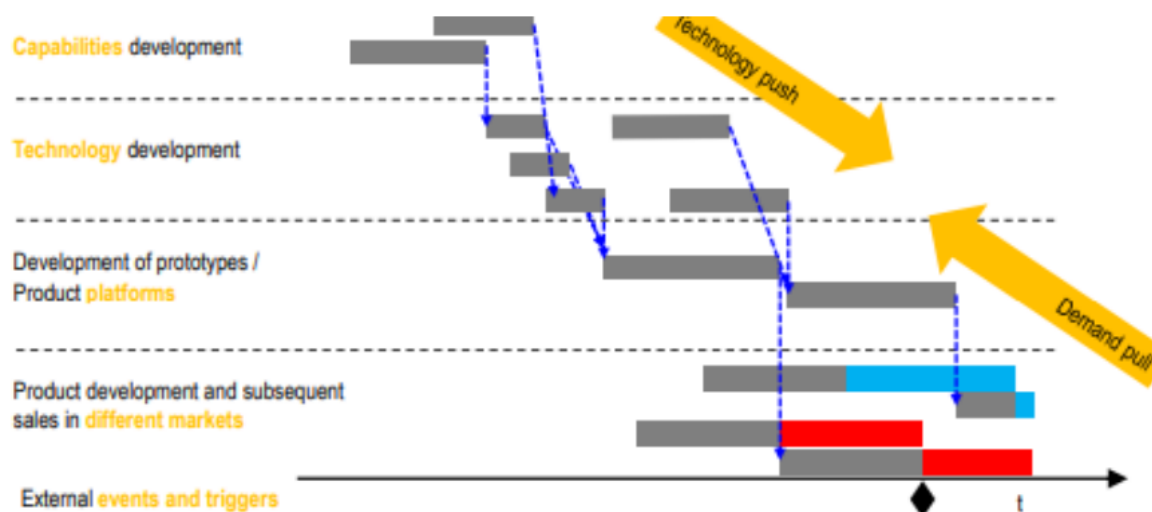

Figure 17 Technology roadmap [18]

When building a technology roadmap, the key steps to consider are:

- **Capabilities development:** Innovation comes from the development of knowledge, competencies and organizational learning. Competences lie between technology and strategy. The first thing to do is to assess if those skills are present in the organization, and in case they are not, whether it makes sense to develop the technology.

- **Technology development:** To consider the actual main activities in order to use those capabilities and achieve the desired technology.
- **Development of prototypes / Product platforms.**
- **Product development and subsequent sales in different markets.**
- **External events and triggers:** The triggers say that no matter how much one develops projects, one cannot take into account all the elements external to the market. Analyses must be carried out according to external events or possible occurrences (such as covid19) that affect the strategies set.

Gantt must be read from the top down and then from the bottom up. First there is a top-down consistency and then a bottom-up consistency. The top-down is technology push, because you have technologies that you want to bring to market. Conversely, demand/market pull coherence is about checking that there are no external stimuli that you have not responded to, and backwards you adjust your planning until you get back the capabilities that you do not have.

4. **Price definition:** Another relevant element in the pre-emptive definition of a plan is a reference price for the product to be created. One of the most suitable methods for assessing the optimal price of a product for the various market segments identified is **the Van Westendorp Price Sensitivity Meter** model. Customers are asked to indicate four different price levels for the product, i.e. a price at which they would not consider buying (too expensive), an expensive price, a price that is considered a bargain, and a cheap price at which they doubt the quality. The four cumulative frequencies corresponding to the different price levels can be plotted.

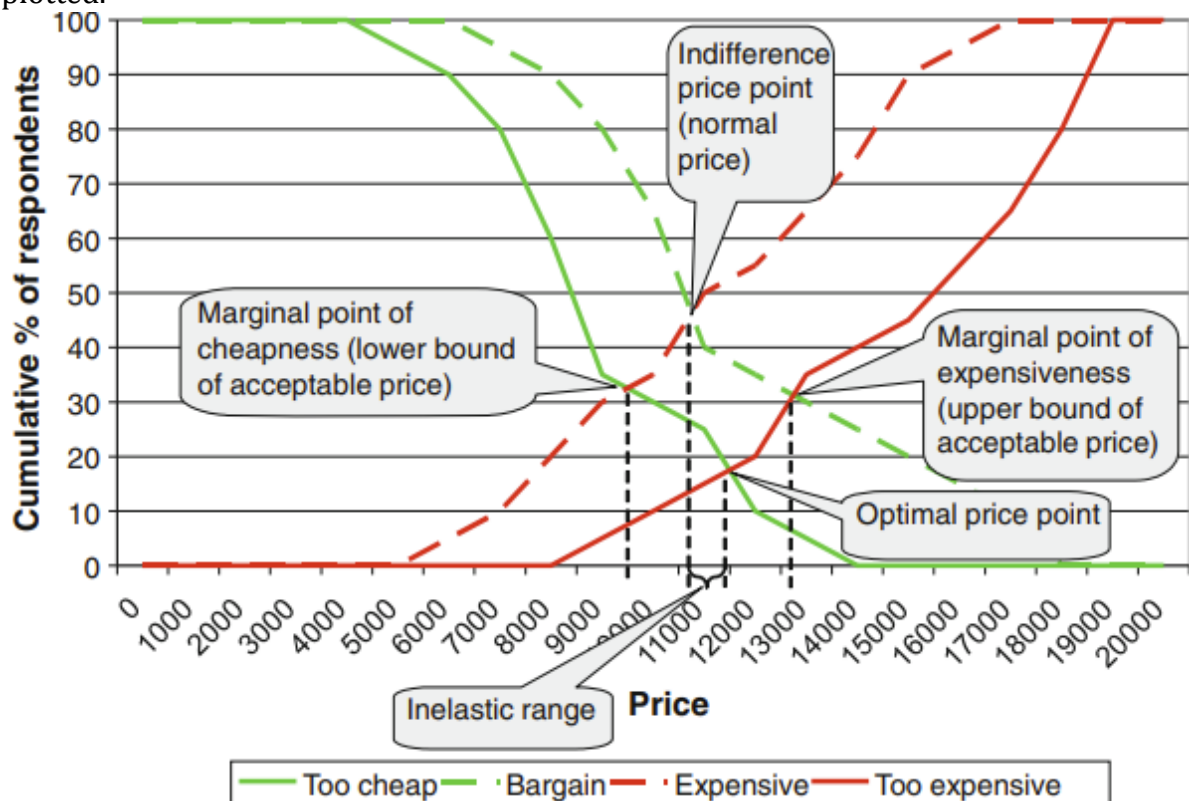

Figure 18 Van Westendorp price sensitivity meter

The intersections of the curves represent the price ranges. The intersection of 'too cheap' and 'expensive' is the minimum acceptable price, as a lower price would lose customers due to the perception of cheapness. The intersection of 'too expensive' and 'bargain' is an upper limit, as raising the price would lose more customers than it would gain. At the intersection of 'bargain' and 'expensive' there is an equilibrium point between the number of respondents who think the product is cheap and those who think it is expensive. This point is known as the Price Indifference Point (PPI). The intersection of 'too expensive' and 'too cheap' gives a price above the PPI. However, the sensitivity of demand from the PPI to this point is low, suggesting that it is the optimal price point (OPP).

1.2.2.3 *Customer needs analysis:*

1. **Gathering raw data from customer:** The first data collected are generally raw and qualitative in nature. At best, they can be defined within an ordinal scale. However, they are the fundamental element for defining as precisely as possible the different types that make up the market segments to be attacked. For this reason, regardless of the tool to be used, it is necessary to take great care not to influence the experiment or the event in general from which these raw data are drawn, to verify the reliability of the answers and, above all, to consider a significant sample and similar to the type of product to be created.

For the definition of products with a strong technological push, especially in B2B contexts, the opinion of experts is the only one that can really be taken into account. Similarly, but in the opposite direction, strong pull B2C products must respond to the functionality of a user who is often unaware of the technology and nature of the product being evaluated.

In this case, it is mainly the latter for which the following data collection tools can be considered valid:

- Interview.
- Focus group.
- Direct observation.
- Scenarios of use.
- User trials.
- Product in use.
- Customer- user diaries.
- Consumer idealized design.
- Association and Communities.
- Surveys.

Another type of tools whose importance has quickly increased since the spread of digital technologies concern the data coming from social media and web in general:

- Web based CRM.
- Search engine marketing (Optimization and advertising).
- Neuromarketing.
- Socialmarketing.

The data collected by these tools can be not only textual, but also images, videos, audios, in more complex cases such as neuromarketing, it can manifest itself in the form of gaze position, if not EEG frequency.

A.I. has a non-secondary impact on data collection, especially if we consider the category of NLP models that can both recognise (and therefore collect) single words and interpret them within a sentence. Similarly, computer vision and speech recognition can act as channels for both the collection and processing of visual and audio data.

2. **Interpret, reduce and hierarchize raw data in terms of customer needs** : If the quality of the data is fundamental to the development of a meaningful study, the logic and method used to carry it out are equally important.

Empathy maps, customer journey maps, experience maps, buyer personas, Kano models are some of the tools that can be used to structure and classify all the raw data. They allow the marketing department to generate customer statements that are as consistent as possible with the needs that generated them and that are useful for identifying them. The needs statements, which are difficult to express in measurable terms, are in turn interpreted to produce the requirements or attributes, which are instead measurable (albeit in a qualitative way) and represent an essential element for the functional definition of the concepts.

S. No.	Features	A	O	M	I	R	Q	Total	Category
1	Cup holders	17	6	12	24	1	1	61	I
2	Electronically adjusted side mirrors	19	8	6	26	1	1	61	I
3	Daytime running LED lights	13	4	6	26	9	3	61	I
4	ABS	5	20	20	11	1	4	61	M
5	2-Airbags SRS system	5	13	20	19	0	4	61	M
6	6-Airbags SRS system	18	17	4	18	1	3	61	A
7	Steering mounted controls	18	11	5	24	0	3	61	I
8	Keyless entry with Start/Stop function	23	5	7	22	1	3	61	A
9	Trunk/Boot auto close button	17	6	2	34	0	2	61	I
10	High definition surround sound system	21	9	9	15	1	6	61	A
11	Leather upholstery	18	4	0	31	4	4	61	I
12	Sunroof	20	4	0	34	0	3	61	I
13	Ventilated Seats	23	6	4	24	1	3	61	I
14	Rain sensing wipers	14	3	3	36	2	3	61	I
15	Automatic headlamps	20	5	4	29	0	3	61	I
16	Rear A/C vents	15	11	13	17	1	3	60	I
17	Rear wipers	8	5	12	35	0	1	61	I
18	Alloy wheels	12	12	5	30	0	2	61	I
19	Apple car play/Android auto	16	8	6	28	1	2	61	I
20	Driver side armrest with storage	19	11	7	21	1	2	61	I

Note: A: Attractive, O: One dimensional, M: Must be, I: Indifferent, R: Reverse, Q: Questionable.

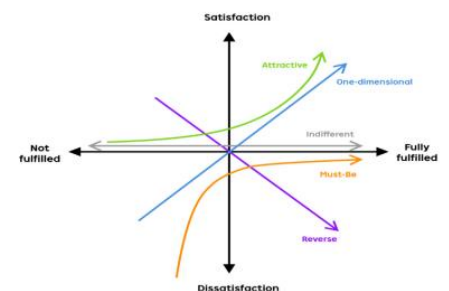

Figure 19 Kano classification [11]

A more structured hierarchy strategy, which does not exclude the use of models such as those mentioned above, is the one that provides for a progressive abstraction from more general needs/attributes to a more restricted set, starting from the answers obtained from a questionnaire. This process is carried out in such a way as to reserve a small number of needs on which to report the various attributes that characterise the market segments under analysis. On the basis of an analysis of the perception map, it is possible to carry out a more meaningful and effective market segmentation.

Three levels of needs can be defined:

- **Tertiary needs:** Elementary or numerous. They can be identified by interacting with customers (e.g. I want to put a lot of suitcases in the boot of my car).
- **Secondary needs:** Identified by grouping the tertiary needs. A product can be defined in 10-20 secondary needs that are detailed enough to be effectively communicated to the customer (e.g. boot capacity and accessibility is a clear and easy to understand concept).

- **Primary needs:** Aggregation of secondary needs. Defines the perceptual space in which products are tacitly represented and compared during the purchase process. They are no more than 2-4 (e.g. perceived self according to the dimensions 'performance' and 'comfort'). The perceptual process is tacit and unconscious, so it can be studied by asking customers to indicate the affinity they perceive between the secondary needs.

From tertiary to secondary needs:

Secondary needs are an aggregation of tertiary needs into a manageable number of higher-level items that are easy to deal with explicitly. Aggregation can be done by grouping similar tertiary needs together. One technique is to write each tertiary need on a card and group them until an optimal result is obtained. The disadvantage is that you are using a perspective that is not your own, but at this level of aggregation the two perspectives may not be very different. To avoid this problem, a small sample of customers can be invited to the exercise. Then, by counting the percentage of times that need i matches need i' , a similarity matrix can be obtained between each pair of needs, and then hierarchical clustering can be used to obtain an objective definition of the secondary needs. Once the clusters have been created, the team needs to provide a concise description of the secondary need that represents the underlying tertiary need.

From secondary to primary needs

Finally, the list of secondary needs needs to be condensed into a limited number of primary needs or perceptual dimensions. They should not be grouped according to supposedly 'similar' elements, as the perceptual process is tacit and unconscious. It would also be unwise to carry out the study on a limited sample of consumers. Therefore, tacit primary needs must be identified by surveying a large and representative sample of consumers using a questionnaire that also provides important insights into a number of other elements. In general, a market research questionnaire will contain a number of sections which, taken together, can lead a company to a better understanding of the market, customer needs and perceptions of competing products. The main sections of a questionnaire may include:

- **Demographics:** captures descriptive variables (e.g. age, gender, income) associated with the respondent and relevant to the analysis. These variables can be used during validation of the dataset to check if the sample is representative of the general population or if there is bias in the responses.
- **Usage patterns:** Questions about how they use the product. This is used to classify the type of user, the occasions and the environment in which use takes place.
- **Importance of secondary needs:** Questions asking the customer to indicate the importance they attach to each of the secondary needs. The degree of importance is usually expressed on a scale of 1-5 or 1-7. The variables obtained are then analysed using ***multivariate statistical*** techniques such as factor analysis. Since factor analysis should be applied to variables measured on an interval (cardinal) scale, while 1-5 is ordinal, the response should be framed as a differential semantic scale.

- **Perceived quality of existing products:** A short list of competing products on the market can be provided and the respondent asked to give feedback on perceived quality. The same list of secondary needs should be used and the respondent should be asked to comment on each item.
- **Price information:** Questionnaires can include questions to estimate the customers' willingness to pay for the product. Based on the resulting data set from the survey, multivariate statistics can be used to derive primary needs from the importance ratings given to secondary needs. Factor analysis is the most commonly used method.

Based on the correlation matrix between the variables x_i , factor analysis models the original variables as linear combinations of a small set of f_k factors (or latent variables). The coefficients of these linear combinations are called λ_{ik} factors. In this application, the factors represent the latent primary needs that customers tacitly process during the perceptual process, but which can be discovered using the statistical approach. In general, the analysis defines 2-4 independent primary needs. A higher number, although explaining more variance, would violate the principle that human decision making is based on a limited number of dimensions.

3. **Customer segmentation:** The development team can now create perceptual maps, which are representations of the primary needs emerging from the market and how the industry is meeting them. If there are clusters, this would be an indication of the needs of customer segments and the potential demand associated with each. It is also possible to look for correlations between the location on the map and variables related to demographics or usage patterns. This can provide a detailed description of market segments and their users. One way of doing product positioning (not to be confused with strategic positioning) is to try to place a product idea within this map.

1.2.3 Concept development:

This is the point at which the aspect of team creativity develops and how it must be incorporated with the colder and much more analytical aspects characteristic of prior activities. At this point, a bridge is created between what the marketing area creates and what the design and engineering area creates instead.

From a more decision-making perspective, always referring to the scheme defined by Mintzberg [51], the main situations encountered by decision-makers fall within the *development* and *selection* phases. That is, they are involved both in the actual development operations of the concept, and in which some identification components can actually enter (for example in the external research phase and partially in the search for the ideal metrics for the product specifications).

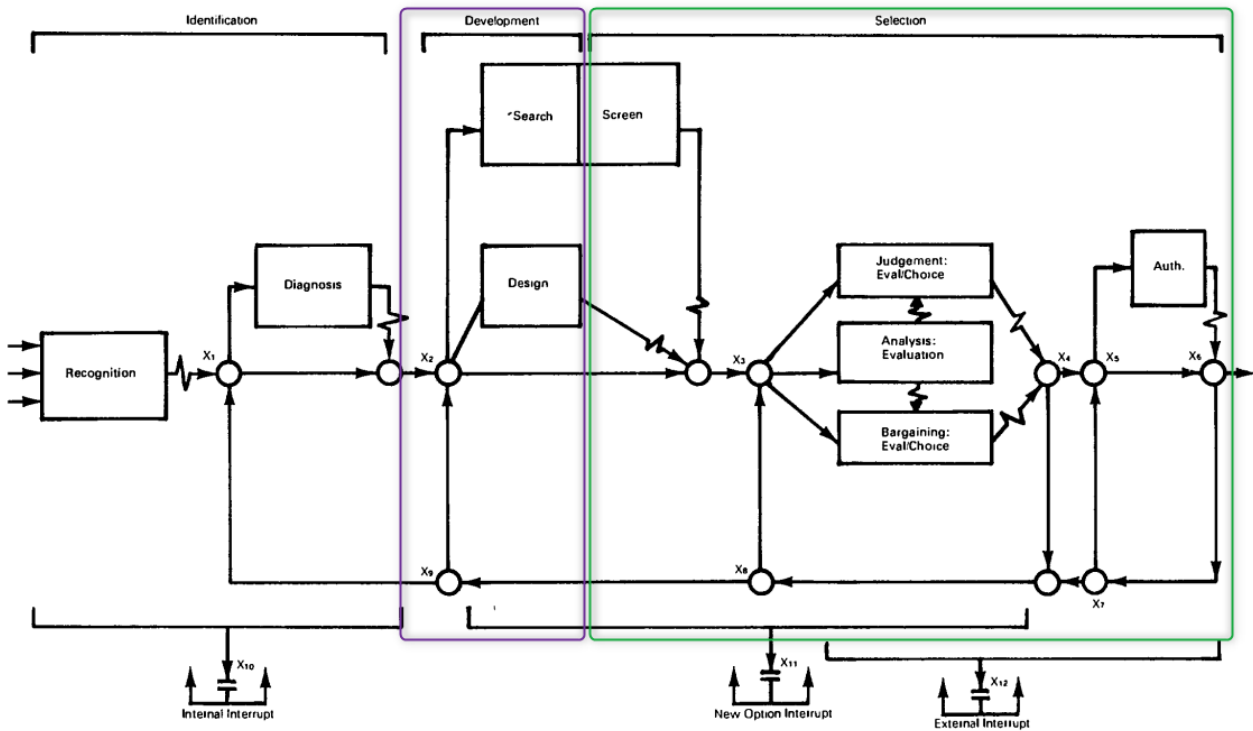

Figure 20 Mintzberg's decision process diagram

The class of processes most present in this phase is undoubtedly that of *Action development processes*. That is to say, the processes aimed at defining alternatives and action plans for realising these alternatives. There is no defined procedure for achieving the objectives defined in the planning phase, but the problems to be addressed are defined and this is sufficient to guide processes of this type. Another name for this type of process is *problem solving processes*, precisely because they focus on solving sufficiently defined problems rather than on collecting and processing data useful for defining the context in which they are located.

Although the main and most important issues are dealt with in the action development processes, the *Choice* process classes, which generally follow the creation of a set of concept, also make a not inconsiderable contribution to the realisation of a product.

There are lots of different models and approaches which guide this activity, however one aspect which unites all of them is the aim of having the ability to place yourself in the shoes of the user-customer and also, after you've succeeded, to attempt to figure out how the product you would like to create truly approaches it, both negatively and positively.

Objectives can be summarized schematically as follows:

- Generate, evaluate, and choose concepts
- Test the hypotheses driving the realization of concepts.
- Begin to develop the procedures for achieving the concepts.

1.2.3.1 Product specifications:

1. **Prepare a list of metrics:** The specifications are the technical equivalent of the functional requirements obtained from the customer's needs. They are, in fact, the metrics that allow you to define how much and how a functional requirement is satisfied by a subsystem/component of the product to be created.

There are several ways of obtaining a relationship between requirements and specifications, usually defined on an ordinal scale (0,1,3,9).

The foundations on which these reports are based are usually derived from the study of a prototype in use by a group of users, or from the opinion of experts. In general, it is the user experience of the different types of customers, real or virtual, that determines the most reliable relationship, but in some cases this is only possible at a later stage, so we start with a predominantly intuitive association.

AI, as image and speech recognition, can help to determine these in the situations of products in use.

In situations where the product is not completely new, but is either a derivative of an existing one, it is possible to refer directly to the specifications of similar products.

AI, as machine learning or, even better, deep learning, can help, if not automate, this process.

The ideal would be to have a 1:1 specification need/attribute association, but it is almost never possible to find yourself in this situation. Instead, it is possible to avoid, as far as possible, associating the same specification with a large number of requirements by going into the definition of each one in detail.

The specifications, in turn, are interrelated. This is because they are linked to what will become the subsystems/components that make up the concept. In the case of a bicycle with parameters such as "maximum forward speed", "wheel diameter" and "frame mass", if the second parameter increases, the first will necessarily increase, and vice versa if the third increases. This simple example illustrates how the problem of making technical trade-offs in order to maximise the satisfaction of development/production needs and costs arises right from the concept phase. The attempt to resolve or overcome these trade-offs is, in fact, the driving force behind the definition of the various technical solutions that incorporate the conflicting specifications and are, therefore, the root of the technical problem to be solved.

Ulrich and Eppinger suggest the following guidelines for the formal definition of a set of product specifications

- **Metric should be complete:** It is better to have multiple specifics to define completely a single need rather than having fewer and not be able to fully reflect each need.
- **Metric should be dependent, not independent, variables:** Specifics have to reflect design choices, not restrict them. They have to reflect the performance derived from design choices, not entail them.
- **Metric should be practical:** Measuring the specific cannot be difficult or expensive.
- **Some needs cannot easily be translated into quantifiable metrics:** These needs need to be further explored at the level of their definition, as they are too subjective.

- **The metrics should include the popular criteria for comparison in the marketplace:** Use popular metrics in the market. This makes the product easier for the customer to recognize.
2. **Competitor benchmarks:** Metrics must also be a means of comparison with the competition. Just as in market segmentation it was essential to determine the position of the various types of customers on the market in relation to a set of needs, so it is necessary to determine the position of the product to be created and that of the competition in relation to a set of relevant metrics. This comparison allows us to understand which are the metrics on which the competition fights and, indirectly, can provide clues as to which are the subsystems that guarantee the competitive advantage over the dominant one.

The critical aspect of this task is to obtain the information to make the comparison. In the world of physical products, it is common practice to carry out what is known as "reverse engineering", i.e. to buy the competitor's product and carry out a series of tests and observations on it in order to understand it in measurable terms.

The House of Quality (HoQ) is a tool that makes it possible to display the various relationships between requirement and specifications (and metrics) at the same time and to compare them with those of the competition.

This tool, together with the needs-metrics matrix, is in fact the means of communication between the work previously done by marketing and that of the engineers/designers. Consequently, its informative value and reliability depend fundamentally on the work carried out during the needs analysis and transformation phase. Since it is a communication mean, its actual appearance can diverge, however, the logic with which it is constructed runs through the points that have been discussed so far.

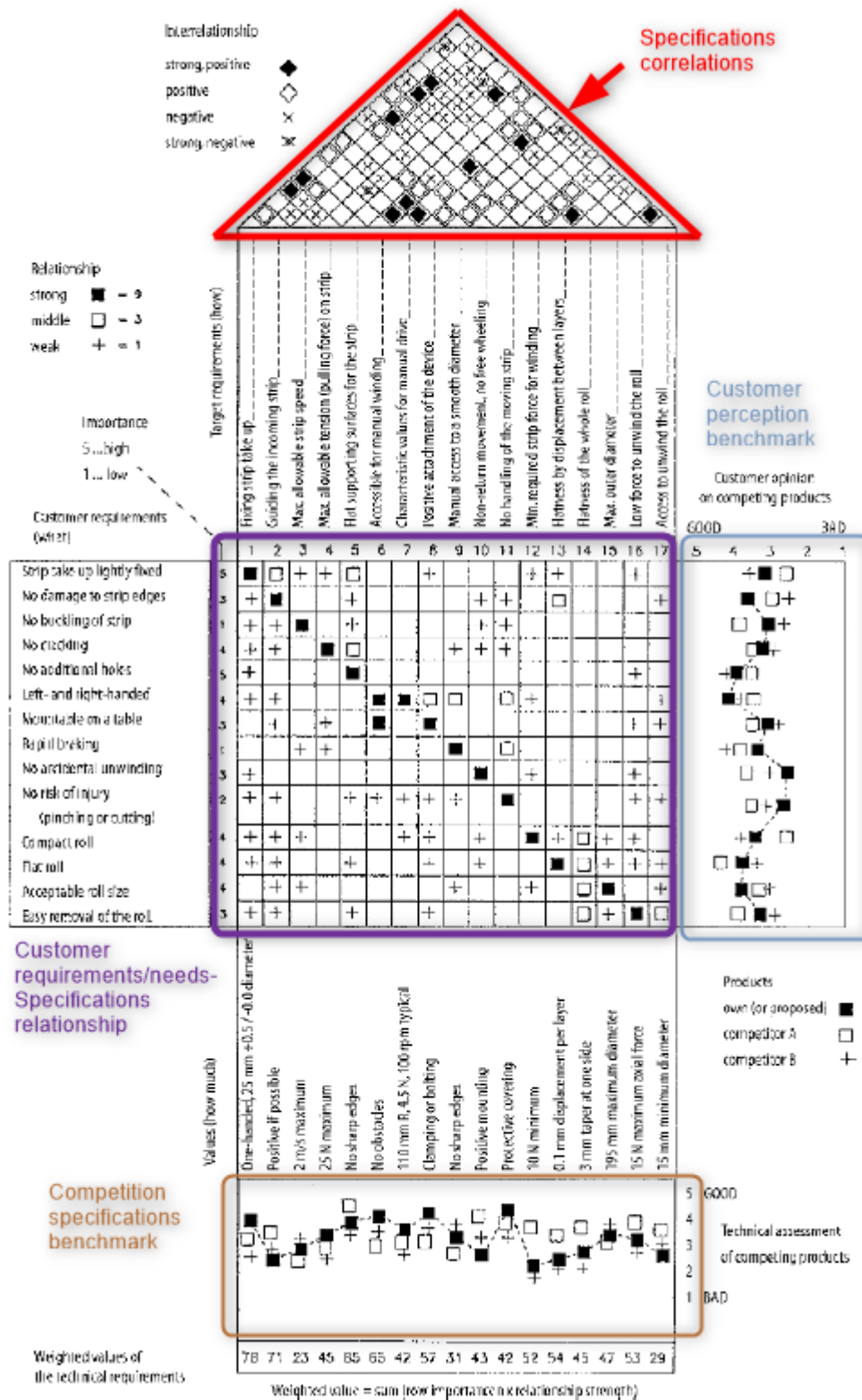

Figure 21 HoQ [9]

The HoQ is embedded in a whole discipline called QFD, which is a progressive process involving more types of these houses. A shortened form of this process involves going through four HoQs:

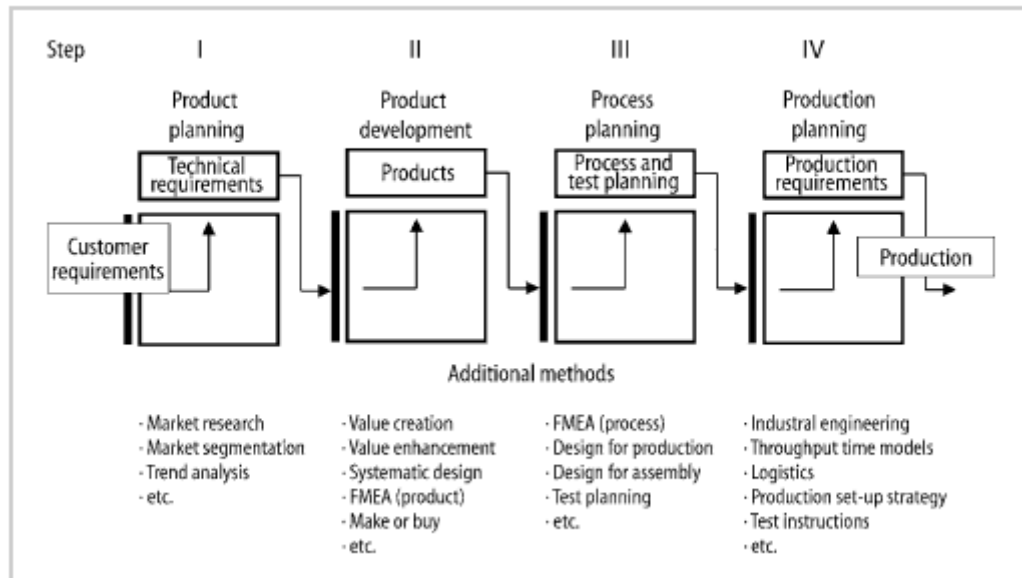

Figure 22 HoQ progression [9]

1. Customer needs/requirements – Specifications/technical requirements.
2. Specifications - Components/Parts (Part/product Deployment).
3. Components/Parts - Key Process Operations (Process Planning).
4. Key process operations - production requirements (production planning).

It is clear, therefore, that the generation of product specifications is also a continuous process, refined as the available information increases.

3. **Set Ideal and Marginally Acceptable Target Values:** However, the iterative nature of this process derives from defining a starting set of specifications, partly obtained qualitatively. These are taken into account at the start of the concept generation and selection activities and are gradually modified as the testing of concepts and prototypes progresses.

They are in fact expectations of the product that the engineering team wants to create and reflect the initial product idea rather than the actual final product. There are no real objective methods for defining this target list unambiguously, but in the case of market pull products, it is good practice to refer to the way in which the organization's products relate to competitors' products and, from the study of the specifications of competitors' products, to define a range/ value to be refined as the tests progress. The end result is called Target specifications list.

Metric No.	Need Nos.	Metric	Imp.	Units	Marginal Value	Ideal Value
1	1, 3	Attenuation from dropout to handlebar at 10 Hz	3	dB	>10	>15
2	2, 6	Spring preload	3	N	480–800	650–700
3	1, 3	Maximum value from the Monster	5	g	<3.5	<3.2
4	1, 3	Minimum descent time on test track	5	s	<13.0	<11.0
5	4	Damping coefficient adjustment range	3	N-s/m	0	>200
6	5	Maximum travel (26-in. wheel)	3	mm	33–50	45
7	5	Rake offset	3	mm	37–45	38
8	6	Lateral stiffness at the tip	3	kN/m	>65	>130
9	7	Total mass	4	kg	<1.4	<1.1
10	8	Lateral stiffness at brake pivots	2	kN/m	>325	>650
11	9	Headset sizes	5	in.	1.000 1.125	1.000 1.125 1.250
12	9	Steertube length	5	mm	150 170 190 210	150 170 190 210 230
13	9	Wheel sizes	5	List	26 in.	26 in. 700C
14	9	Maximum tire width	5	in.	>1.5	>1.75
15	10	Time to assemble to frame	1	s	<60	<35
16	11	Fender compatibility	1	List	None	All
17	12	Instills pride	5	Subj.	>3	>5
18	13	Unit manufacturing cost	5	US\$	<85	<65
19	14	Time in spray chamber without water entry	5	s	>2300	>3600
20	15	Cycles in mud chamber without contamination	5	k-cycles	>15	>35
21	16, 17	Time to disassemble/assemble for maintenance	3	s	<300	<160
22	17, 18	Special tools required for maintenance	3	List	Hex	Hex
23	19	UV test duration to degrade rubber parts	5	hr	>250	>450
24	19	Monster cycles to failure	5	Cycles	>300k	>500k
25	20	Japan Industrial Standards test	5	Binary	Pass	Pass
26	20	Bending strength (frontal loading)	5	kN	>7.0	>10.0

Figure 23 Target specifications list [25]

4. **Specification refinement:** The specification refinement process is not linear or clearly codified. However, as in the case of opportunity identification, structuring and classifying the various types of data generated by the sequence of activities is the best way to orientate oneself and to understand which specification reference values are useful to maintain and which need to be redefined.

The driving force behind this remodeling is essentially defined by the trade-offs that any product development process has to face. These trade-offs are mainly motivated by technical design choices, such as the choice of a particular power source, technical manufacturing choices, such as the use of a specific technique to obtain the components or the procedures with which to carry out the assembly, economic choices, as in cases where a rigid target cost is defined, but also marketing choices, such as the

prioritisation of a function perceived as more important by the target customers.

- **Technical models:** The purpose of creating an engineering model is to be able to numerically evaluate how a given set of design choices can affect the various specifications. It also defines the effective correlation between the specifications themselves and can be used to support the resolution of technical design and manufacturing trade-offs.

It is defined by specific tests carried out on virtual/analytical and physical prototypes and is, in fact, the tool of excellence for determining what is known as **Technical feasibility**. AI has brought improvements both in terms of increasing the computing power of the workstations on which the CAE software is run and in terms of optimising the CAE software itself in terms of simulation of the concept/prototype, finding the optimal solution given a set of physical constraints and usability.

However, these tools are neither absolute nor universal, but can be used in conjunction with other analytical software/models that incorporate knowledge/data produced by the organisation in charge of the product development process.

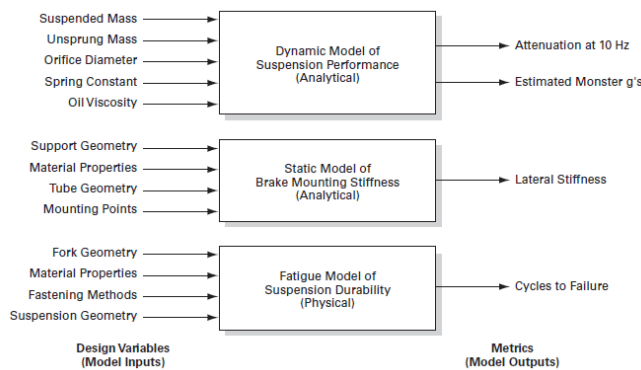

Figure 24 Technical models examples [25]

For example, a team of designers can dimension components based on models derived from the experience of other projects and carry out virtual prototyping using CAE software.

In fact, it is now possible to implement models directly on the CAE software, integrating it by inputting the personal model using APIs provided by the software vendor. However, organisations may be reluctant to do so in order not to risk the diffusion of that part of the knowledge that guarantees a competitive advantage.

- **Cost models:** It is the basis on which the cost of the product is calculated. There are two main types of methods: Qualitative and Quantitative. The former is used in the preliminary phases by looking at the cost of similar products, and therefore by analogy, or they reason intuitively from a target cost based on past experience, while the latter are used when the product idea is more structured and can be cataloged in two families: Parametric or analytical. The parametric methods are the most practical but require a solid database capable of determining a dynamic and detailed model of all the components that make up the product.

These methods are supported by BoM and Activity Schedules/Work Cycles and maintenance forecasting, and as the characteristics of each of them vary, it defines the planned COGS taking in consideration the entire product lifecycle. Together with these, analytical methods are used that take into account economic and learning phenomena that also have a strong impact on COGS and cannot be easily defined in advance. The Crawford model is an example of an analytic model that can determine the reduction in costs in terms of man-hours required to produce each unit of a product. In general, when direct cost data is not available, analytical models are used to predict costs based on other quantitative elements.

This type of logic works also for each subsystem that composes a complex system like an automobile or an aircraft.

RDTE & PROD cost estimation results @ subsystem level.

Cost Items	RDTE Cost Estimation [M€ FY2020]	PROD (TFU) Cost Estimation [M€ FY2020]
Propellant Subsys	113.77	21.37
Thermal Protection Subsys	791.78	10.92
Thermal and Energy Management Subsys.	49.48	33.39
Integration	5097.00	36.01
Structure	13,471.00	825.82
Landing Gear	111.36	7.45
Environmental Control Subsystem (ECS)	449.73	23.59
Ice Protection Subsystem (IPS)	149.91	4.10
Fire Protection Subsystem (FPS)	160.62	3.73
Flight Control Subsystem (FCS)	621.06	37.26
Avionic Subsystem	209.87	13.66
Electrical Power Subsystem (EPS)	749.55	283.14
Water Subsystem	128.49	1.99
Oxygen Subsystem	128.49	2.48
Lights Subsystem	64.24	1.86
Furnishing	74.95	0.75
STRATOFLY MR3 Cost (w/o engines)	22,371	1308

Figure 25 Cost estimation table [19]

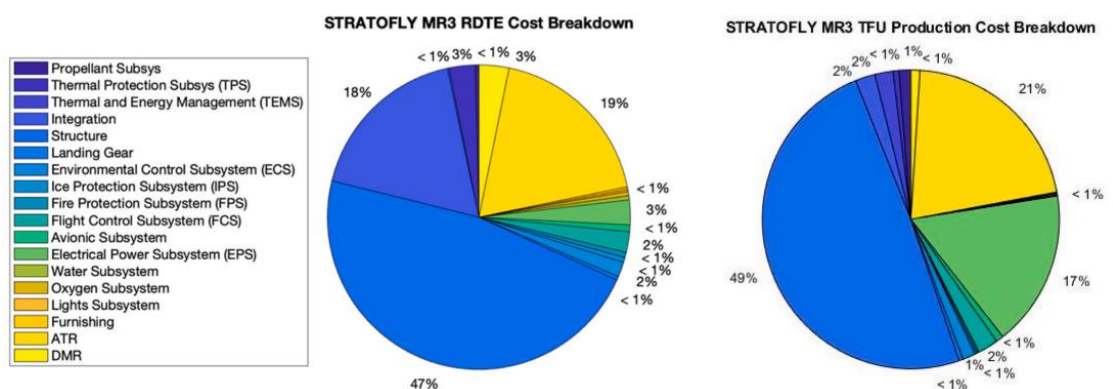

Figure 26 Cost breakdown [19]

- **Competitive models:** The choice of final specifications is not only determined by technical/engineering and cost factors. In order to assess the value and importance to be attached to a set of specifications, it is advisable to consider how the organisation manages to achieve certain values compared to the

competition. In general, the data used directly within the HoQ to determine the position of competitors with respect to the specification under consideration is considered, while it is more complex to define the costs that allowed them to achieve this value.

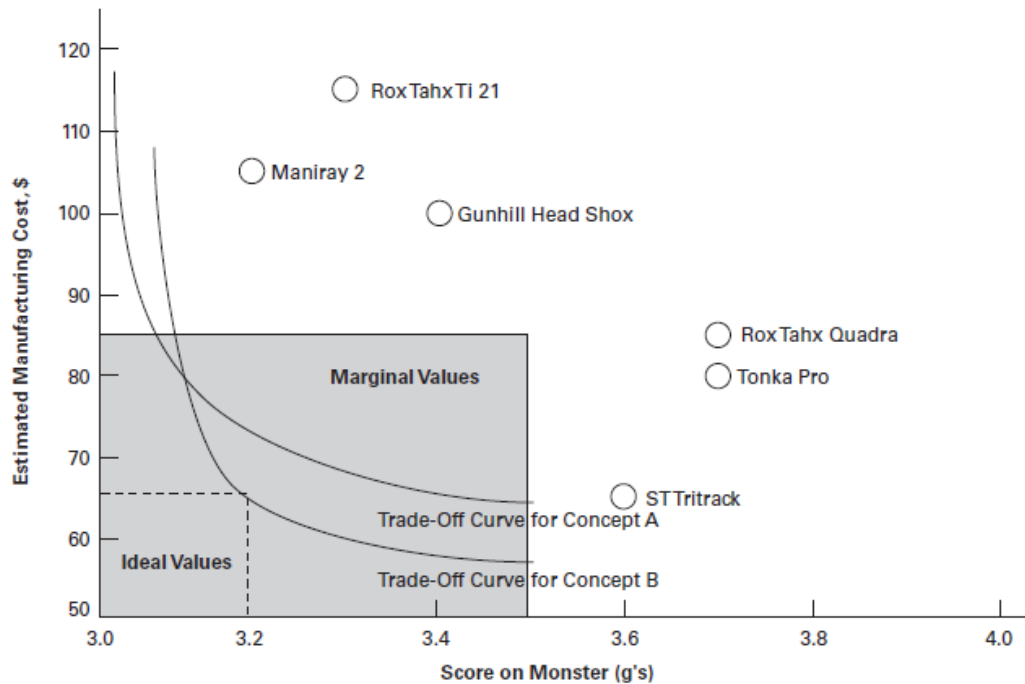

Figure 27 Product benchmark [25]

- Specifications flow down:** The flow down of specifications is undoubtedly the most difficult operation and is based essentially on the experience of the team and the tests carried out on the whole system. This activity is therefore characteristic of complex products where different subsystems interact and influence each other. Logically, the more complex a system is, i.e. with a high number of components, the more difficult this activity becomes. Another factor to consider in this situation is the number of relationships between the different components and the different subsystems. Highly intertwined architectures lead to complexity indices that do not allow easy placement of specifications at the lowest levels.

1.2.3.2 Concept generation:

In this phase, designers create rough sketches or models to illustrate their ideas and evaluate different options. These sketches represent different concepts and briefly describe how a product should satisfy a customer need. The starting point for the realisation of these concepts is the functional requirements derived from the needs and objectives described above. There is no single way to achieve this result and, in general, the generation of these concepts is not a linear process. However, the authors propose a structured process that allows for the clarification of the main problems encountered at this stage.

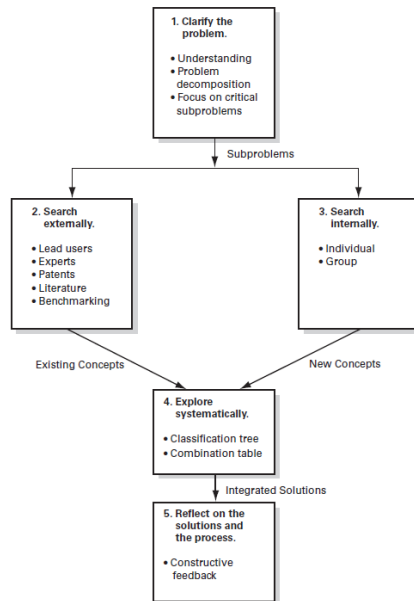

Figure 28 Concept generation scheme [25]

1. **Clarify the problem:** In order to clarify the problem, all the information generated in the needs and objectives phase is taken into account. If they are not sufficient to generate an effective solution, it is necessary to go back to this phase and clarify all the elements that are difficult to interpret.

The decomposition of the problem is fundamental to structure the actual problem. In the case of complex objects, it is at this stage in which the basic functional ideas of various concepts come to light, which will be implemented in detail in the subsequent phases of detailed design. One of the basic tools for solving this problem is **functional decomposition**.

In fact, the concept is understood as a black box capable of satisfying a specific functional requirement. It considers all those sub-functions, defined in terms of energy, material and information/signal, that can lead to the satisfaction of the initial functional requirement.

As it is possible to understand from the diagram, this process is extremely iterative and provides for a progressive increase in the level of detail in the definition of the sub-functions.

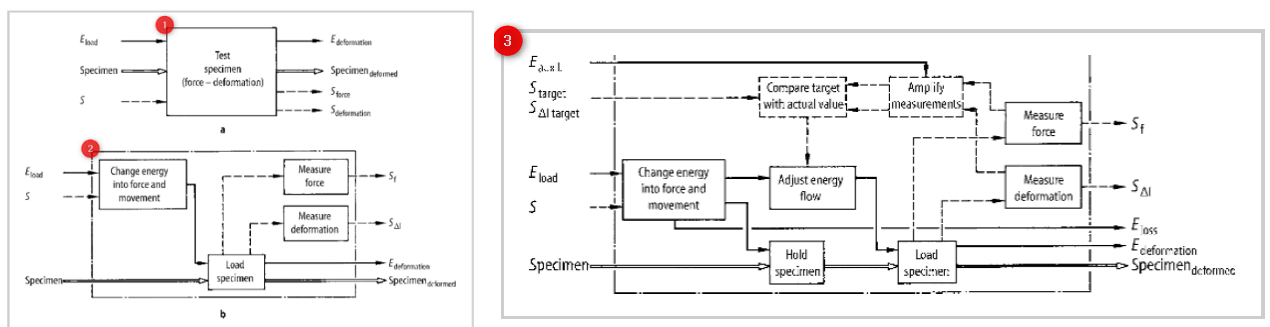

2. **Search externally:** External research is configured as a fundamental means of identifying ready-made or partially implementable solutions. The solutions are not

Figure 29 Tensile testing machine functional diagram [25]

necessarily related to a similar product. Rather, the focus is on finding a product, a subsystem, that can perform the function for which the design team cannot find a solution.

The focus is on the source of the solution rather than the way in which this solution is found. In general, these are the main type of reliable sources of solutions:

- **Lead users:** They often have already invented rough solutions in order to meet their own needs.
- **Experts:** They can be professional consultants, professors, suppliers and in general, anyone who has gained extensive experience in relation to various products that can be used to solve the problem faced by the designers. The main thing to bear in mind is that they usually charge a fee, which must be taken into account when preparing the budget.
- **Patents:** It is advisable to refer to them in order to avoid any fines associated with their infringement.
- **Specific literature:** They can be extremely useful sources because they contain all the valuable technical data that designers need, and because they tend to be written in a handbook style, making them easy to read in the hands of experienced designers.
- **Related products:**

3. **Search internally:** This phase is about creativity, in term of the ability to find solutions based on the team's internal knowledge. This is where new knowledge is created within the company and is therefore a fundamental stage in the development of the entire organisation's ability to face design challenges.

These new solutions come both from the interaction of the different members of the group in brainstorming sessions and from the individual reflections of each member. The authors offer some ideas to consider during the internal research phase:

- **Suspend judgment:** product decisions can have long-term effects. Rather than criticizing ideas, use perceived flaws as opportunities to improve or suggest alternatives.
- **Generate a lot of ideas:** The quantity of ideas a team creates can aid in comprehensive solution exploration. Quantity also fosters more idea sharing and stimulation, which can result in even more ideas.
- **Welcome ideas that may seem infeasible:** Embrace ideas that seem unworkable initially, as these can be improved by team members. These boundary-stretching ideas push the team's thinking limits, expanding the solution space.
- **Use graphical and physical media:** Verbal language often struggles to effectively describe physical information. Therefore, employing visual aids like sketches or 3D models can better facilitate understanding of form and spatial relationships.
- **Make analogies:** Designers often look at devices solving similar problems or nature (biomimetics) for inspiration. They can also consider the problem at different scales or in unrelated areas. This can lead to innovative concepts

- **Wish and wonder:** Starting thoughts with "I wish..." or "I wonder..." can inspire new possibilities and rethink problem boundaries
- **Use related stimuli:** New ideas can often be stimulated by related cues. Sharing ideas within a group, referring to customer needs, or looking at product usage environments are effective ways to generate these stimuli.
- **Use unrelated stimuli:** Random stimuli can stimulate new ideas. This can involve randomly picking images or capturing street photos, which can serve as inspiration and a refreshing change of pace.
- **Set quantitative goals:** As concept generation can be tiring, setting numerical targets, like generating 10 to 20 concepts, can be a motivating force.
- **Use the gallery method:** This involves displaying concept sketches on a wall for group discussion, allowing for explanations, improvements, and generation of related concepts, blending individual and group efforts.

A more structured method to find new solutions is TRIZ. In particular, Ulrich and Eppinger refer to two elements of that theory:

- **The 40 inventive principles:** TRIZ identifies 40 general principles that can be applied to solve inventive problems. These principles range from segmentation to self-service, and they serve as a toolkit for engineers and inventors to generate innovative solutions.
- **The contradiction matrix:** This is a tool that helps users identify the appropriate inventive principles to apply in resolving specific contradictions. The matrix is organized by 39 engineering parameters and maps the relationships between them, guiding users to the most relevant principles for their problem.

4. **Explore systematically:** After conducting both external and internal searches, the team will gather numerous concept fragments, which are potential solutions to the subproblems. To systematically explore these possibilities, the team will organize and synthesize these solution fragments to navigate through the range of options available. The two main tools, referred to the development of a nailer, proposed by the author are:

Concept classification tree.

- **Pruning less promising branches:** If a solution path appears less fruitful, it can be pruned, allowing focus on more promising routes. For instance, despite the appeal of nuclear energy for the nailer team, the approach was pruned due to practical and regulatory concerns.
- **Identifying independent approaches:** Different branches of the tree can represent independent solutions, enabling teams to divide efforts and foster healthy competition. The nailer team assigned promising chemical/explosive and electrical approaches to different subteams.

- **Exposing inappropriate emphasis:** The constructed tree helps teams quickly identify if efforts have been misallocated, guiding further focus. The nailer team realized they hadn't considered hydraulic energy enough and dedicated more time to it.
- **Refining problem decomposition for a specific branch:** Tailoring the problem breakdown to a particular approach can be useful. The nailer team added a subfunction of "accumulate translational energy" to their electrical energy branch upon realizing the need for a large, sudden power release.

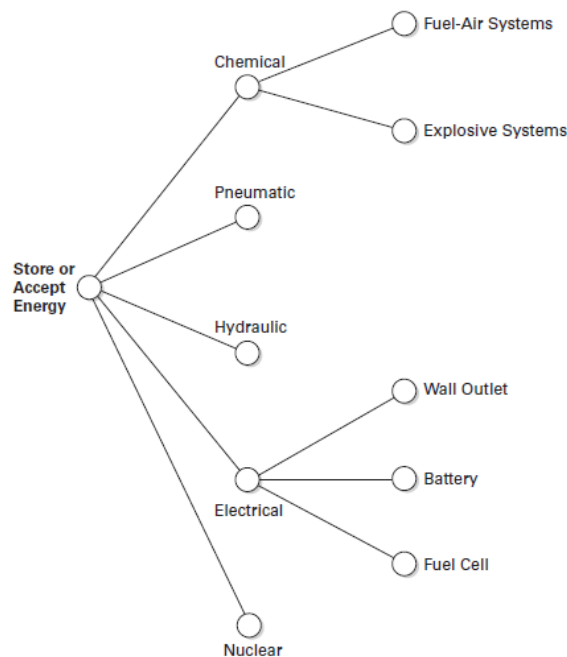

Figure 30 Classification tree [25]

Concept combination table:

The concept combination table is a systematic way to mix solution fragments. The columns represent different subproblems and the entries are potential solution fragments for each. The table aids creative thinking by forcing associations among these fragments, but doesn't instantly yield a complete solution.

Two guidelines streamline this process:

- **Eliminate infeasible fragments:** If a fragment can be deemed unworkable before being combined, it reduces the number of combinations to consider. For example, discarding the 'rail gun' solution reduces the combinations from 24 to 18.
- **Focus on coupled subproblems:** The table should emphasize subproblems whose solutions need evaluation in combination with others. Independent subproblems, like choosing between a battery or a wall outlet, can be left out, reducing the number of combinations to consider. The table becomes less useful when it exceeds three or four columns.

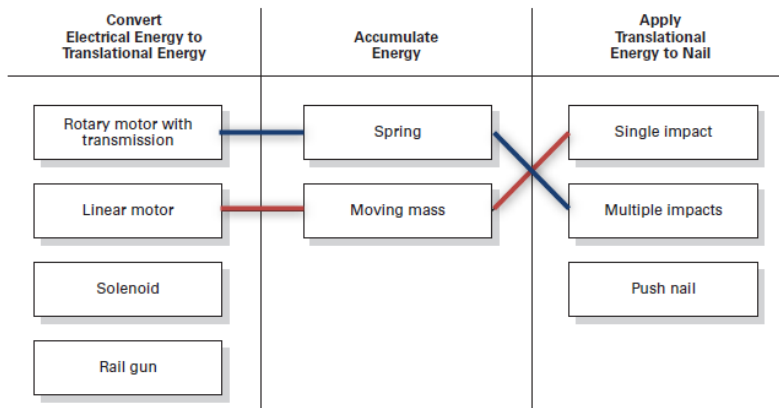
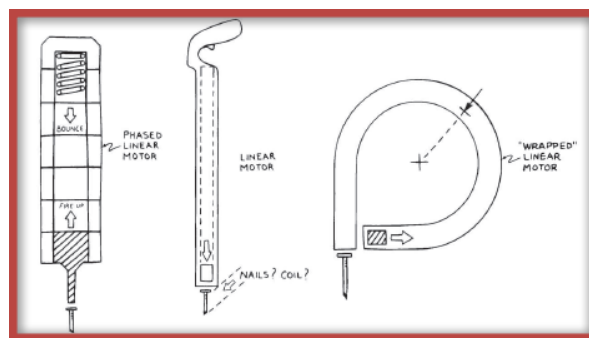
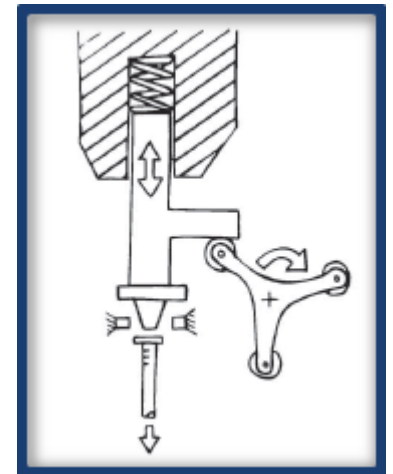

Figure 31 Combination table [25]



1.2.3.3 Concept selection:

Concept selection involves assessing various ideas based on various factors and customer requirements, knowing the advantages and disadvantages of each idea, and also picking a single or even much more for more exploration, experimentation, and development. At first, an extensive range of ideas is narrowed down to a smaller selection. Nevertheless, these shortlisted concepts may afterwards be amalgamated and magnified, temporarily expanding the number of ideas being considered.

Concept screening.

Concept screening, dependent on Stuart Pugh's method, seeks to rapidly decrease the quantity of concepts and perfect them. This particular involves:

- **Preparation of the Selection Matrix:** Teams develop a matrix of criteria and concepts for evaluation. Ideas must be described uniformly for impartial comparison. The staff selects a benchmark idea for comparison. If a lot of ideas are present, multivoting may be utilized to limit the choices.
- **Rating the Concepts:** Concepts are scored as 'better than', 'same as' or 'worse than' the benchmark across various criteria. Objective metrics, when offered, will help lower the subjectivity of the process.
- **Ranking the Concepts:** The staff totals the scores for every principle and also ranks them depending on the net score (number of 'better than' scores minus 'worse than' scores).
- **Improving and combining the Concepts:** The staff examines the ideas, looking for ways to combine or even enhance them by eliminating negative features or perhaps

merging good ones from numerous concepts. Combined or even enhanced concepts are put into the matrix, ranked, and placed together with the first concepts.

- **Select More than one Concepts:** After the analysis of every principle and the quality of its, the staff decides on the principles to advance for more refinement based on the resources of theirs as well as the promising aspects of the principles. The team likewise identifies issues needing additional investigation before final selection and determines whether an additional round of screening or perhaps a far more comprehensive idea scoring procedure must be used.
- **Select One or More Concepts:** After the evaluation of each concept and its quality, the team decides on the concepts to advance for further refinement based on their resources and the promising aspects of the concepts. The team also identifies issues requiring further investigation before final selection and decides whether another round of screening or a more detailed concept scoring process should be applied.

Selection Criteria	Concepts														
	Handcuff	Master Lock	Velcro Belt	Rubber Belt	Alligator Clip	4-Part Latch (REF)	Torsional Spring	Screw Type	Wing Nut	Clothespin	Hose Clamp	C-Clamp	Spring-Loaded Bar	Magnetic Plates	Threaded Bar
Functionality															
Lightweight	+	0	+	+	+	0	+	-	-	+	0	0	+	+	0
Fits different bars	+	0	+	+	+	0	0	0	0	+	0	+	0	-	0
Weights secured laterally	0	0	-	-	0	0	0	-	+	-	0	0	-	0	+
Convenience															
Tighten from end/side	0	0	0	0	0	0	-	-	-	0	-	0	+	+	-
Does not roll	0	0	0	0	0	0	0	0	0	0	0	0	0	0	0
Change weights without removing collar	0	0	0	0	0	0	0	0	0	0	0	0	+	+	0
Convenience of placement when changing weights	0	0	+	+	0	0	-	-	-	0	-	0	+	+	-
Ergonomics															
Secure/release (one motion)	+	0	-	-	+	0	-	-	-	0	-	-	+	-	-
Low force to secure/release	0	0	0	0	-	0	-	0	0	0	0	0	+	-	0
RH/LH usage	0	0	0	0	0	0	0	-	-	0	-	-	0	0	-
Not slippery when wet	0	0	+	+	0	0	0	0	0	0	0	0	+	+	0
Use with one hand	+	0	0	0	+	0	0	0	0	0	0	0	+	+	0
Durability															
Longevity	-	-	-	-	0	0	0	+	0	0	+	+	-	-	+
Other															
Cost of raw materials	0	0	+	+	0	0	0	-	-	+	0	0	-	-	-
Manufacturability	0	-	+	+	0	0	0	+	-	+	+	0	-	-	-
Uses existing weight bars	0	0	0	0	0	0	0	0	0	0	0	0	-	0	-
Sum +s	4	0	6	6	4	0	1	2	1	4	2	2	8	6	2
Sum 0's	11	14	7	7	11	16	11	8	8	11	10	12	3	4	7
Sum -s	1	2	3	3	1	0	4	6	7	1	4	2	5	6	7
Net Score	3	-2	3	3	3	0	-3	-4	-6	3	-2	0	3	0	-5
Rank	1	10	1	1	1	7	12	13	15	1	10	7	1	7	15

Figure 32 Screening comparison matrix [25]

Concept scoring.

- **Prepare the Selection Matrix:** This step involves developing a matrix together with the principles being examined on a single axis and also the selection criteria on the other person. This particular matrix is usually constructed with a pc spreadsheet to facilitate ranking and sensitivity analysis. The selection criteria might be refined or even detailed further according to the insights from the idea screening stage. Importance weights are put into each criterion, oftentimes subjectively influenced by staff consensus.

- **Rate the Concepts:** Each idea is ranked against each criterion. A finer scale is utilized in this action to provide much more comprehensive differentiation among concepts. Reference points might be specified to make a standard for rating, along with these may differ for various requirements to stay away from scale compression.
- **Rank the Concepts:** The weighted scores are calculated by multiplying the raw scores by the requirements weights. The amount of these weighted scores provides the entire score for every idea. Each concept will be ranked based on the total score of its.
- **Combine and Enhance the Concepts:** The team appears for ways to perfect, blend, or enhance the ideas depending on the scores and rankings. This can frequently result in innovative enhancements to the product concepts.
- **Select More than one Concepts:** This's not really a simple process of picking the highest ranked idea. The staff ought to perform a sensitivity analysis to explore the outcome of variations in ratings and weights on the idea ranking. A number of concepts could be selected for more development, testing, and prototyping. The team may also create several scoring matrices to accommodate various market segments or maybe customer preferences.

Selection Criteria	Weight	Concept A		Concept C		Concept F		Concept I		Concept J		Concept K		Concept O	
		Rating	Weighted Score	Rating	Weighted Score	Rating	Weighted Score	Rating	Weighted Score	Rating	Weighted Score	Rating	Weighted Score	Rating	Weighted Score
Flexible Use	20														
Use in different locations	15	7	105	7	105	8	120	6	90	6	90	5	75	7	105
Holds different beverages	5	5	25	5	25	3	15	4	20	5	25	3	15	3	15
Maintains Drink Condition	15														
Retains temperature of drink	13	5	65	5	65	5	65	1	13	5	65	5	65	5	65
Prevents water from getting in	2	5	10	7	14	5	10	5	10	5	10	5	10	5	10
Survives Boating Environment	5														
Doesn't break when dropped	1	6	6	6	6	9	9	7	7	5	5	9	9	6	6
Resists corrosion from sea spray	2	7	14	7	14	8	16	8	16	5	10	9	18	7	14
Floats when it falls in water	2	5	10	6	12	8	16	4	8	5	10	8	16	7	14
Keeps Drink Container Stable	20														
Prevents spilling	7	3	21	4	28	3	21	5	35	5	35	3	21	3	21
Prevents bouncing in waves	6	7	42	8	48	7	42	5	30	5	30	7	42	7	42
Will not slide during pitch/roll	7	5	35	5	35	5	35	5	35	5	35	5	35	5	35
Requires Little Maintenance	5														
Easily stored when not in use	1	7	7	6	6	8	8	9	9	4	4	8	8	7	7
Easy to maintain a clean appearance	2	6	12	6	12	3	6	4	8	5	10	5	10	6	12
Allows liquid to drain out bottom	2	5	10	5	10	5	10	5	10	5	10	5	10	5	10
Easy to Use	15														
Usable with one hand	5	7	35	7	35	7	35	6	30	5	25	7	35	7	35
Easy/comfortable to grip	5	8	40	8	40	6	30	5	25	5	25	6	30	8	40
Easy to exchange beverage containers	2	5	10	5	10	5	10	8	16	5	10	5	10	5	10
Works reliably	3	3	9	3	9	3	9	3	9	4	12	4	12	3	9
Attractive in Environment	10														
Doesn't damage boat surface	5	8	40	8	40	8	40	8	40	8	40	6	30	8	40
Attractive to look at	5	7	35	8	40	3	15	4	20	5	25	5	25	8	40
Manufacturing Ease	10														
Low-cost materials	4	5	20	4	16	7	28	8	32	4	16	8	32	6	24
Low complexity of parts	3	4	12	3	9	7	21	4	12	3	9	8	24	5	15
Low number of assembly steps	3	5	15	5	15	8	24	3	9	3	9	8	24	6	18
Total Score			578		594		585		484		510		556		587
Rank			4		1		3		7		6		5		2

Figure 33 Scoring comparison matrix [25]

1.2.3.4 Concept testing:

In a concept evaluation, the product development group seeks feedback on the proposed product concept from potential customers inside the planned market. This form of evaluation may be used to choose between several concepts, collect ideas for enhancing a concept out of prospective customers, and then to gauge the possible market need for the item. It is essential to be aware that other types of customer engagement and tests is able to happen at stages beyond just the idea development stage.

- **Define the Purpose:** The goal of the idea check have to be identified in the context of the brand new product development process and also the choices which will be made depending on the test 's results.
- **Choose a Survey Population:** The survey population has to be selected. This might include prospective customers, inner company personnel, and other stakeholders. The selection of population must reflect the intent behind the test and also the decisions it'll support.
- **Choose a Survey Format:** A good survey format needs to be selected, whether it is qualitative (like focus groups) and quantitative (like internet surveys). This depends on factors such as for instance the maturity of the nature and the concept of the info needed.
- **Communicate the Concept:** The product idea is communicated to respondents in a manner that will help them comprehend it effectively enough to offer helpful feedback. This may be through verbal descriptions, prototypes, sketches, or several other methods.
- **Measure Customer Response:** The result of prospective customers on the product concept is calculated. This usually entails asking them about the likelihood of theirs of purchasing (Van Westendorp method) the item and the reason they respond how they actually do. The suggestions of theirs for improvement may additionally be collected.
- **Interpret the results:** The end result of the idea test are viewed to inform future choices. If a single idea obviously outperforms others, it can be picked for more development. When results are much less clear, factors as cost can come into play. Estimated future need for the item, dependent on survey responses, might in addition contribute to your decisions. The end result must be interpreted with caution, since all influencing factors.

1.2.4 System level design:

This section additionally consists of common embodiment design concerns. It is stated, though, that these phases are conceptually different: Embodiment design takes place after system level design and before comprehensive design. This stage entails changing the system - level design right into a more concrete and in depth design. The attention now moves from the whole system as well as its parts to how precisely those components will likely be realized.

From a decision-making point of view, nothing changes from what was previously defined in 1.2.3, except that at this point the information base is certainly greater and the actual tests carried out on the various concepts are necessarily greater.

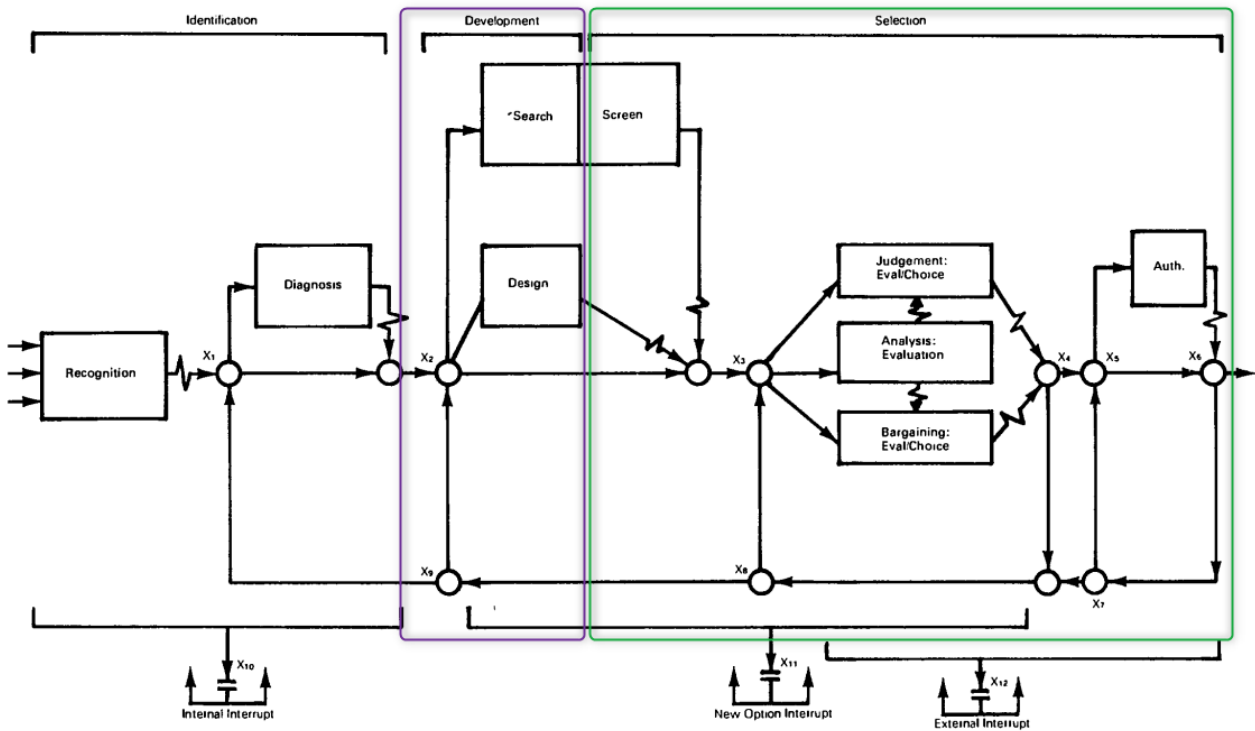

Figure 34 Mintzberg's decision process diagram

The crucial tasks in embodiment design could include:

- Selecting the correct materials and manufacturing procedures for every component.
- Defining the thorough layout or configuration of components.
- Creating prototypes or preliminary designs to validate the design

The product architecture describes the alignment of functional elements of the product with tangible components. It deals mainly with describing the basic physical components of the product, determining their roles and determining their interconnections within the complete system. This architectural outline illustrates how detailed testing and design of these components will likely be distributed among teams, people and possibly external suppliers. A structure such as this encourages the parallel development of various parts of the product, therefore boosting efficiency and collaboration.

A highly modular product architecture is defined by the simple fact that each functional component of the product is connected with an individual, separate physical part. In addition, these single parts or "chunks" interact in a limited and clearly defined fashion. This modular approach enables modifications in the individual parts to be made without impacting the others, letting them function effectively and be designed fairly independently.

A product having an integral architecture, on the other hand, is usually designed with best performance as a prioritization. In this case the functional elements may be distributed over a number of physical parts. Delineation among these elements might not exist or might not be clearly defined. To be able to optimize certain performance parameters, a lot of functional elements will be combined into a small number of physical parts. Modifications to an individual component or feature, though, might call for a complete product redesign, since the components are interconnected.

Modularity isn't a total characteristic of a product architecture, it is important to understand. The products are hardly ever entirely modular or integral, but generally exhibit a mix of these characteristics.

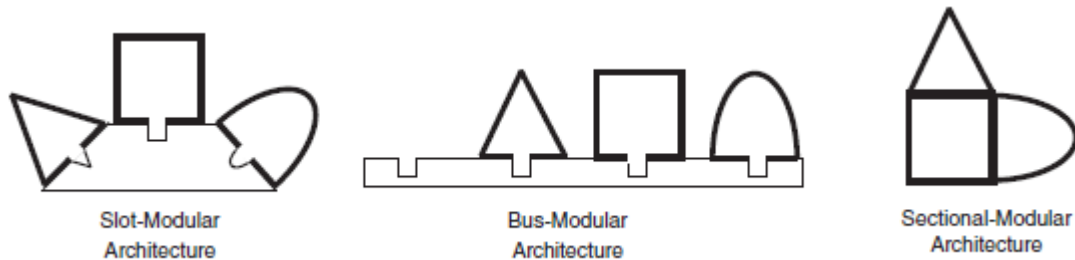

Figure 35 Type of modular interfaces [25]

1.2.4.1 Establishing the Architecture

- **Create a Schematic of the Product:** Start off with a diagram which describes all of the components of the product. A few of these elements are actually realized, a few are crucial parts while some others continue to be physically embodied and therefore are discussed solely in functional words. This schematic design reflect current knowledge of the product, although it does not have to include every last detail. A helpful strategy could be limiting the number of elements in the schematic to less than thirty.

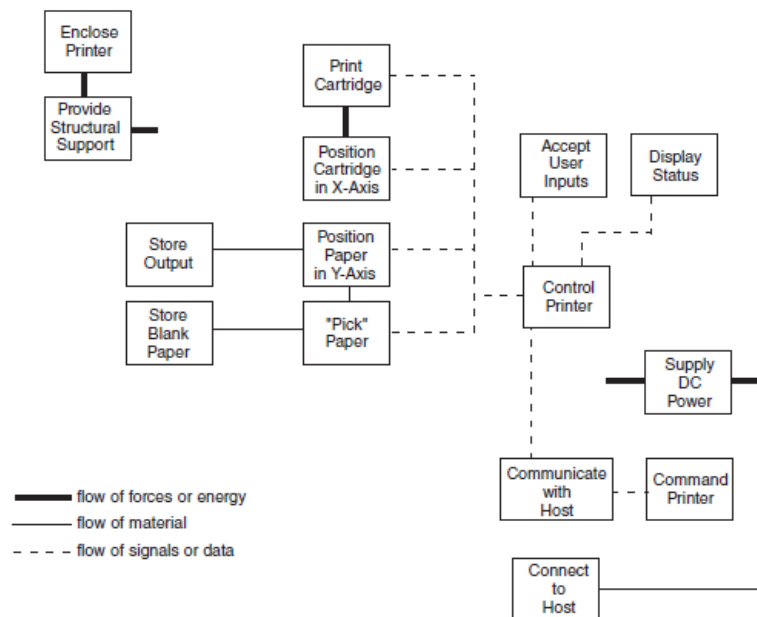

Figure 36 Schematic example [25]

- **Cluster the Elements of the Schematic:** Next step will be assigning the components of the schematic to "chunks." These chunks may be understood as the product's physical or functional units. The clustering choice has been affected by numerous factors, including geometric integration, accommodating variety, changes anticipation, technology similarity, vendor capabilities, function sharing, enabling standardization as well as interaction portability.

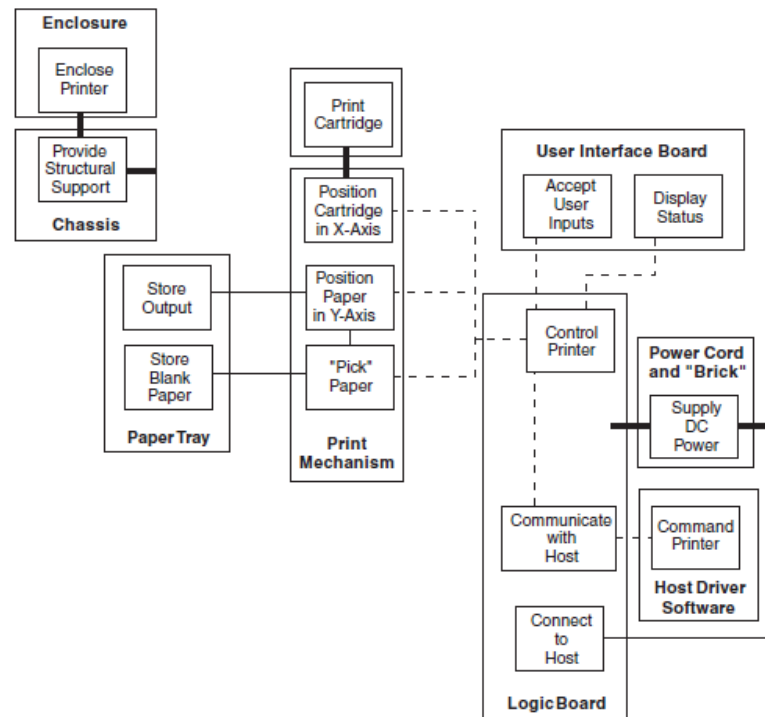

Figure 37 Clustered schematic example [25]

- **Create a Rough Geometric Layout:** This step entails producing a two or three dimensional geometric layout and showing the positioning as well as interaction of these chunks. This step calls for the team to evaluate the viability of geometric interfaces and also understand dimensional relationships of all the chunks. In the event that issues of aesthetics in addition to human interface are important, industrial designers must be involved in this step.
- **Identify the Fundamental and Incidental Interactions:** Each chunk may be designed by various people or groups, and that means there'll be interactions between the chunks. It's crucial for good coordination as well as information exchange to identify these interactions, both direct (planned) as well as accidental (unplanned). Interactions may be presented visually making use of a interaction graph for small systems or an interaction matrix for bigger systems.

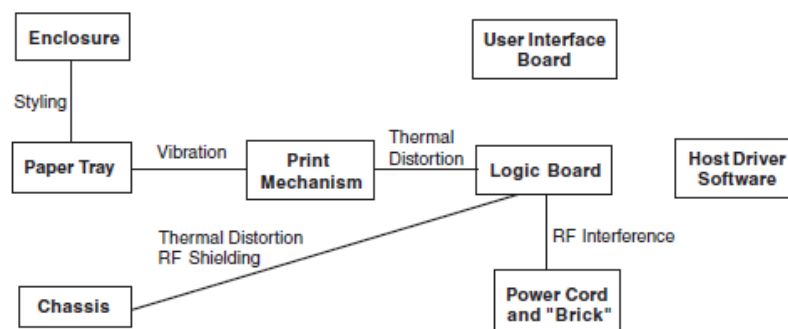

Figure 38 Incidental interaction graph [25]

The process needs to concentrate on strong communication as well as coordination among the groups responsible for each part of the process. Fundamental interactions as well as incident interactions influence these coordination requirements. Interacting chunks could be developed independently in some instances in case their interaction could be reduced to a completely specified interface.

This particular process calls for updating of the schematic, interaction graph or diagram as the understanding of the product grows. This particular system of interactions referred to as system architecture is a developing entity which evolves with the advancement of the product.

1.2.4.2 Trade-Off between Differentiation and Commonality

This is typical of the circumstance during the development of a product that's related to a common platform. This is typical in the automobile industry, in which car series designs are shared by subsystems. In platform planning, the task is striking a sense of balance between the demand for product differentiation and also the need for component commonality. This trade off is amplified as companies try to customize their products to meet up with the requirements of the market segments, while reducing costs through shared components. Below are a few important considerations:

- **Quantitative analysis of cost and revenue implications:** Decisions must be made on more detailed analyses, like estimating the effect of a rise in market share on sales compared to the possible increase in production and supply chain expenses, from extra product versions.
- **Iterative approach:** When compared with fewer iterations, and that concentrate much more on the specifics, quick iterations based on approximate information usually lead to better decisions.
- **Influence of product architecture:** The architecture of the product decides the balance between commonality and differentiation. Modular architectures generally permit greater component sharing compared with integral architectures. Thinking about alternate architectural techniques can, consequently, help solve disputes between commonality and differentiation.

1.2.5 Detailed design:

The refinement stage, also referred to as the stage of detailed design, marks the conclusion of the design process. Here the technical product is finalised when it comes to specifications such as geometry, dimensions, selection of material as well as surface characteristics for every component. This phase also takes a deep look at the examination of manufacturing methods, functional protocols as well as cost structures.

From a decision-making point of view, nothing changes from what was previously defined in 1.2.3, except that at this point the information base is certainly greater and the actual tests carried out on the various concepts are necessarily greater. Also the development in this phase deals with the actual manufacturing processes problem and therefore the development take in deep consideration also these type of variables that in the previous phases are less relevant

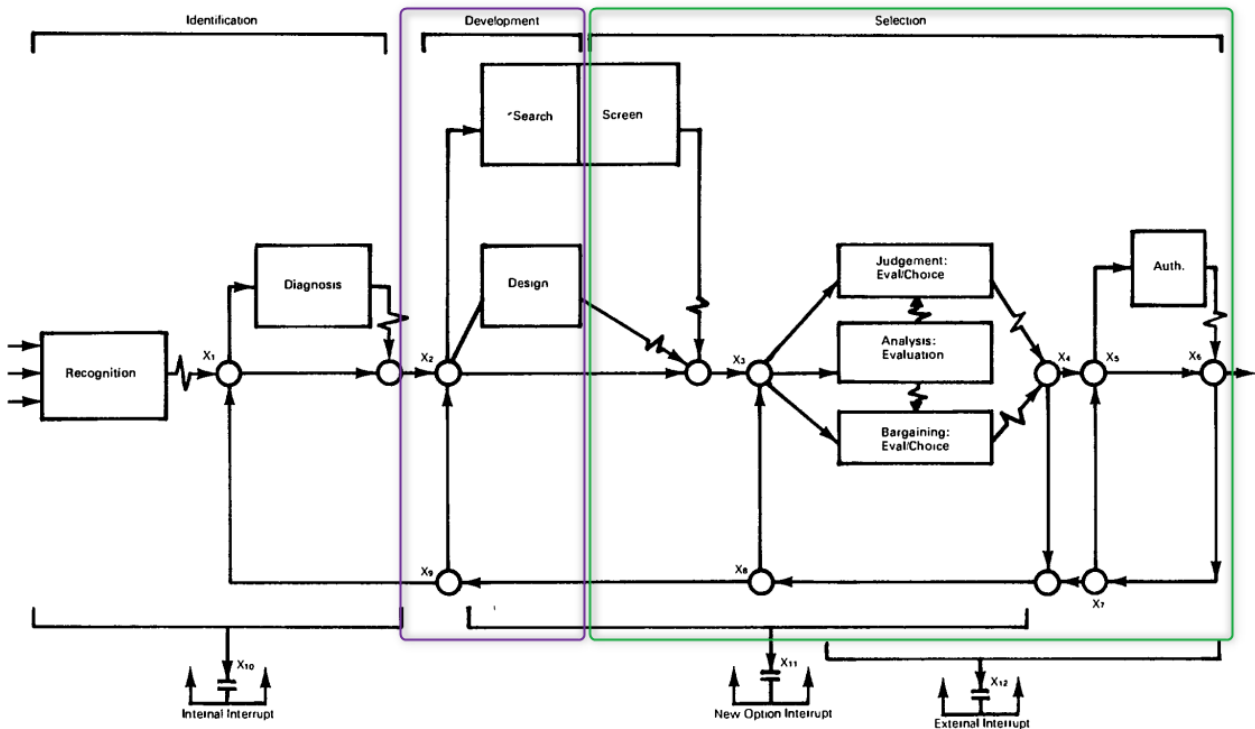

Figure 39 Mintzberg's decision process diagram

Principal goals of this phase are: The main objectives of this phase are:

- Detailed design and engineering of the product
- Deep analysis of single components and architecture
- Manufacturing process detailed definition
- Scheduling, define and supervise costs and risks connected to the manufacturing process
- Ensuring the production of documents for communication between the parties involved

One of the most critical areas of the detailed design stage is the construction of an extensive documentation of the production. This entails precise diagrams of components, directions for assembly, and parts inventories. These duties are generally carried out in the modern day era using Computer Aided Design (CAD) software. This particular technical help helps with the immediate use of product information for the planning of production and operation of machines for Computer Numerical Control (CNC).

The design team will also need to supply assembly instructions, shipment documentation as well as quality assurance procedures to the manufacturing division, based on the product and manufacturing scheme (singular unit, small series or large scale output). The final consumer must also be given operating, maintenance and repair manuals. These documents make up the basis for the fulfillment of the order as well as the planning as well as supervision of the production.

Here's the breakdown of the detail design phase:

- **Layout Finalization:** This involves the detailed drawing of the components as well as the thorough optimization of the shapes, surfaces, materials, fits and tolerances. The

aim is to stick to standards while maximizing the utilization of optimum materials and also attaining cost - effectiveness as well as production ease.

- **Component Integration:** The components are incorporated into the assemblies as well as the final product. This procedure is impacted by production planning, delivery dates as well as assembly and transportation considerations.
- **Production Documentation** The production documents come complete with instructions for production, assembly, transport as well as operation..
- **Document Verification:** All documents, particularly the detailed illustrations and components lists, are inspected for compliance with in-house and general standards, the reliability of sizes as well as tolerances, vital manufacturing information as well as ease of obtaining.

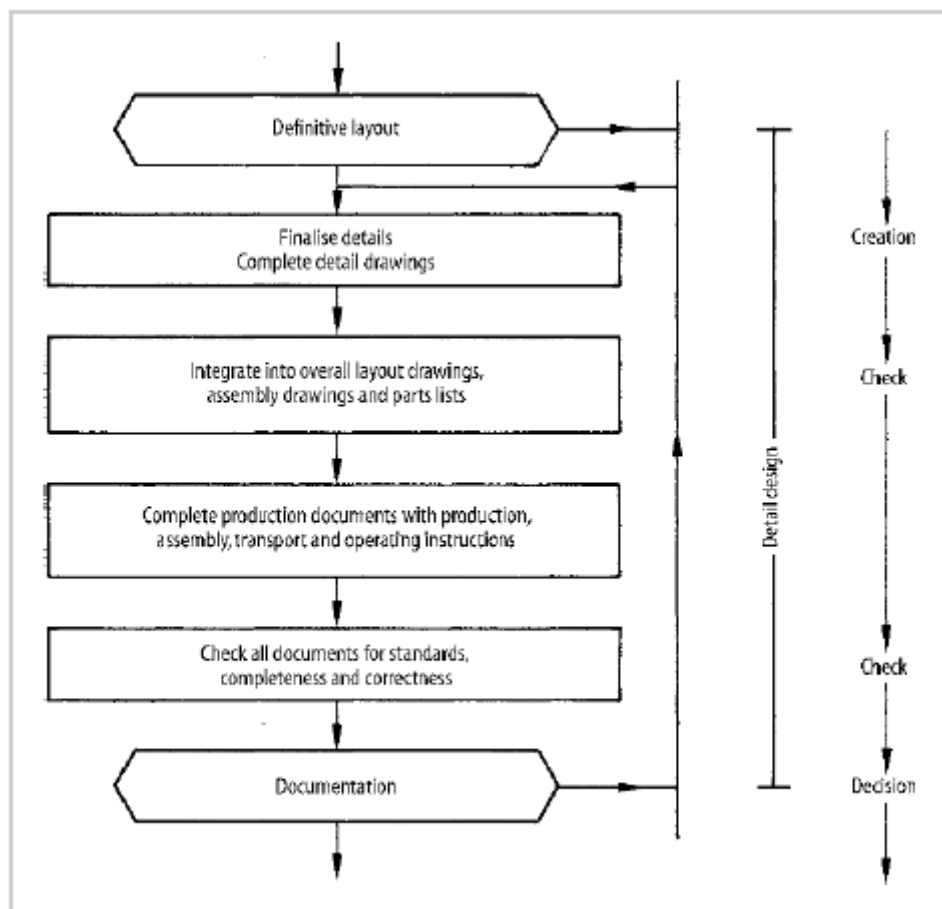

Figure 40 Detailed design steps [10]

Be aware that the stages of the detailed design stage usually overlap with the prior design stages, particularly for components with a long lead time. The phase of the detail design is extremely particular to the product and the domain and sometimes relies on different technical manuals, supplier catalogues as well as standards.

The phase of detail design is crucial to the technical features of the product, to the tasks of production and also to the prevention of production mistakes. It has a direct effect on the sales success of the product as it greatly impacts the production costs and also the quality of the product. Consequently, it's important that you be thorough at this stage.

1.2.6 Prototyping:

Contrary to what happened in the previous phases, the decision making process here is strongly focused on *Selection*, i.e. the fundamental purpose of the decision makers here is to verify the actual hypotheses about the functioning of the prototype; therefore, on the basis of the results of the tests, to be able to understand which are actually the most effective and significant technical solutions adopted. The fundamental difference with respect to the way choice/selection is understood in 1.2.3. is related to the way in which the validation and examination of possible alternatives is carried out, here focusing on the technical and engineering functioning of the product rather than on its attractiveness and ability to respond to market needs.

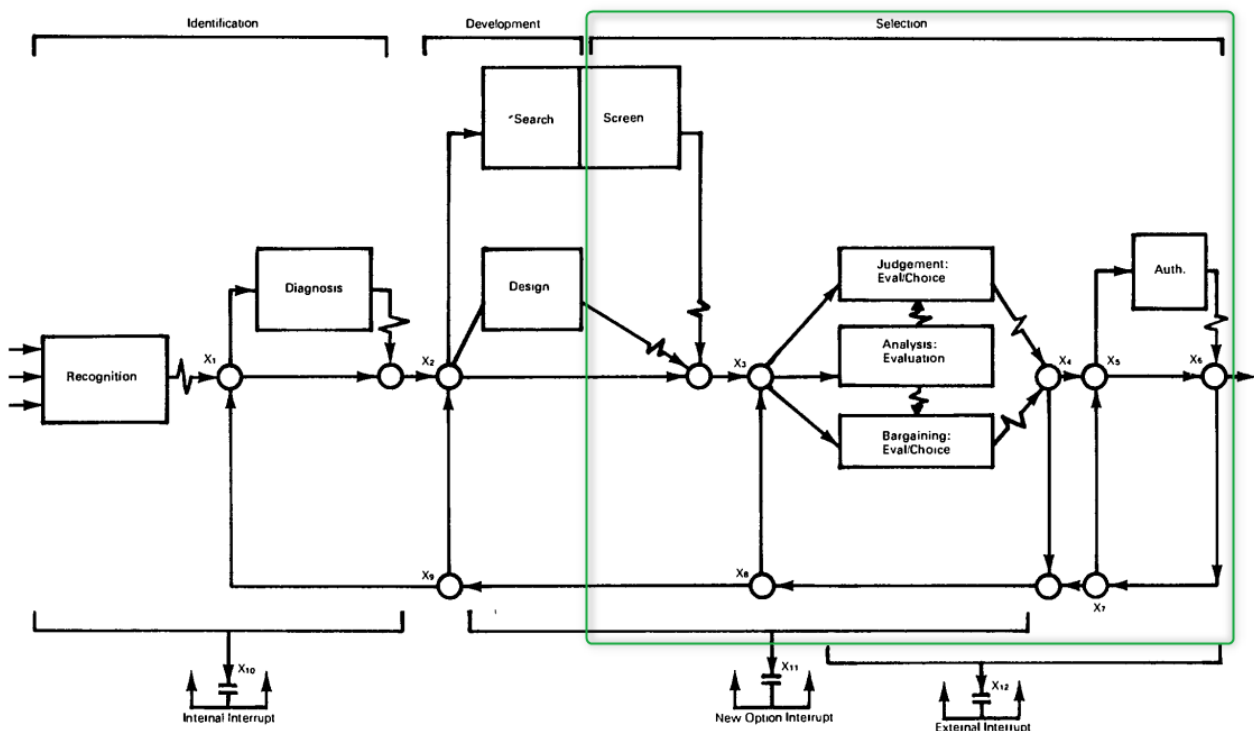

Figure 41 Mintzberg's decision process diagram

Specifically, those classes of *Choice* solution processes are primarily activated during this phase, since both the context and the problem to deal with are structured and well defined.

The category prototypes, which are invaluable tools in product development, may be classified on two criteria: Their comprehensiveness as well as their physicality.

Physical prototypes are tangible constructions which imitate elements of the final product.

They facilitate experimentation and testing through carrying out hands - on experiments.

Analytical prototypes, on the other hand, stand for the product in a non-physical, usually visual or mathematical fashion.

The second criteria, comprehensiveness, relates to the scope of the prototype. A comprehensive prototype consists of all or nearly all of the characteristics of the product, operating as a fully operational, full scale version of the product. This prototype is commonly utilized for final customer testing prior to going into mass production. A focused prototype, on the flip side, concentrates on one element or a group of characteristics of the product. It could be a foam model to figure out the shape of the product or a hand built circuit board to

determine electronic performance. Oftentimes, 2 focused prototypes, one that "works like" the product and yet another that "looks like" it, are utilized in combination to analyze overall product performance.

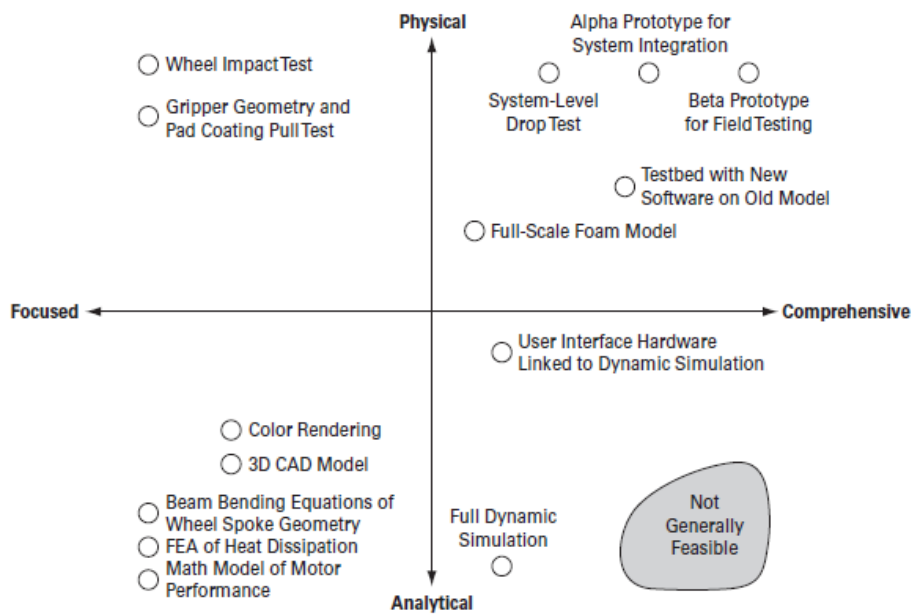

Figure 42 Prototype types [25]

Prototypes are crucial in product creation for four reasons : learning, integration, communication as well as serving as milestones.

- **Learning** is part of the main function of prototypes, helping answer questions like "Will it work" or "Will it fulfill consumer needs." Utilizing both concentrated physical prototypes as well as focused analytical prototypes, similar to mathematical models, speeds up the acquisition of knowledge as well as testing.
- **Communication** They act as tangible representations that improve understanding among stakeholders like management, vendors, customers and investors. Physical models tend to be particularly effective for this purpose due to their tactile and visual attributes.
- **Integration** is the third purpose of prototypes, which would be to make sure that all components as well as subsystems work coherently. Comprehensive physical prototypes are especially useful for this since they call for assembly of all parts and therefore require coordination among team members. This process can produce functional conflicts among components. The synchronization of a variety of perspectives inside the development team is additionally facilitated by comprehensive prototypes.
- **Milestones** are utilized to show the progress as well as functionality of the product during the utilization of prototypes. These prototypes function as tangible goals, showing improvement and enforcing the project timeline. Oftentimes, a milestone prototype which demonstrates certain capabilities must be presented to senior management or the buyer prior to the task is able to proceed.

Eppinger and Ulrich think about the 2two major technologies 3D computer assisted design (3D CAD) along with free form fabrication. 3D CAD enables effective visualization, automated

calculation of physical characteristics and also can serve as an analytic prototype usually reducing the demand for physical ones. Rapid prototyping, also called free - form fabrication, allows for the creation of items from 3D CAD models. It's quicker and less expensive, enabling much better communication of product concepts. The application of AI has significantly enhanced both. This particular integration has established brand new abilities for these tools, such as the chance to train a ML model and apply its predictions to CAD models, and also improved earlier functions such as the speed and precision of simulations performed on the model itself.

In product development, "hardware swamp" refers to unneeded prototyping attempts which do not add significantly to the project objectives. To avoid this, each prototype needs to go through careful planning. This four step method could be applied to any prototype: establish the objective of the prototype, establish its approximation level, outline an experimental program and produce a timetable for procurement, construction as well as testing.

Define the Purpose of the Prototype: Clearly establish the goal of the prototype, taking into consideration the prototype's role in learning, integration, communication, along with milestones. This requires an understanding of the particular requirements as well as objectives of the prototype inside the bigger development project.

Establish the Level of Approximation of the Prototype: Determine just how much the end product ought to resemble the prototype. This calls for careful evaluation if an analytic or physical prototype might far better serve the purpose determined in step one.

Outline an Experimental Plan: Develop a strategy to make use of the prototype as an experiment, determine the variables being examined, develop a protocol, arrange the measurements and begin a procedure for the evaluation of the data.

Create a Schedule for Procurement, Construction, and Testing: Create a timeline for the prototyping tasks, determining key dates such as assembly readiness, first tests, and conclusion of tests.

1.2.7 Design for manufacturing (DFM):

This is undoubtedly a fundamental component of product development, as it profoundly affects the manufacturing cost component of the product and, consequently, the unit margins associated with the product, both in cases where the price is defined both on the basis of COGS and on the basis of customer WTP. Economically successful design necessitates high product quality and low manufacturing cost - a goal that DFM effectively achieves.

This is where the final decisions on the actual design of the product and its parts are made, based on the actual availability of the organisation in terms of production resources available internally and externally. However, these decision choices require a greater structuring, not so much of the problems to be defined, which in themselves arise in connection with the detailed design, but rather of the actual production capabilities and availability of the company. Therefore, even those more identifying components of the information base, although not highlighted in the reference diagram, are again predominant because they are directly involved in the planning and product review phase.

Referring to Minzberg's scheme, the *selection* and *development* processes are more relevant, but it is reiterated that the identification that takes place in planning and product review is

also aimed at creating a sufficiently developed information base to support this phase of a more productive nature.

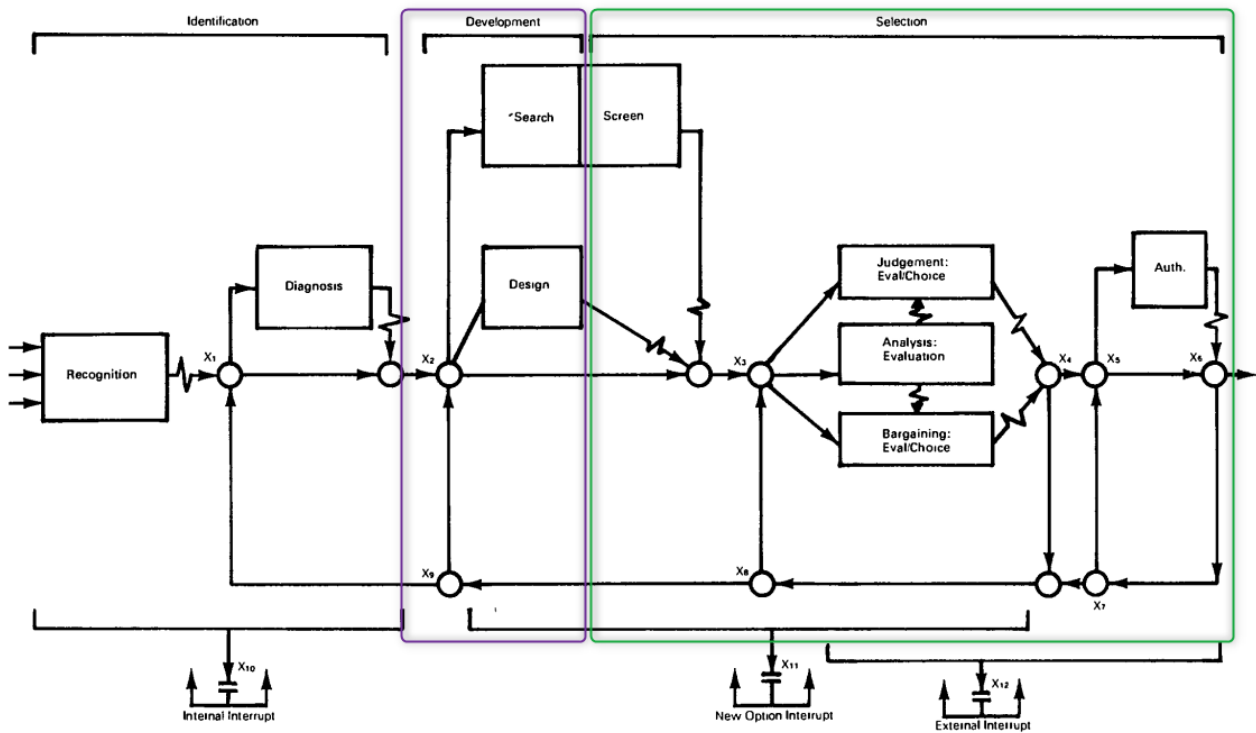

Figure 43 Mintzberg's decision process diagram

From the point of view of the decision support process classes, both *Action structuring* and *development* are particularly relevant, while those of *Choice* play a minor role.

DFM is a *highly integrative practice* in product development. It employs a myriad of information types - sketches, drawings, product specifications, design alternatives, a detailed understanding of production and assembly processes, and estimates of manufacturing costs, production volumes, and ramp-up timing. As such, DFM mandates contributions from a majority of the development team and external experts, requiring the expertise of manufacturing engineers, cost accountants, and production personnel, in addition to product designers.

DFM is initiated during the concept development phase, where product functions and specifications are being decided. Cost is a primary consideration when choosing a product concept, despite the highly subjective and approximate nature of cost estimates at this phase. With product specifications finalized, the team has to negotiate trade-offs between desired performance characteristics. A system-level design phase follows, where decisions are made about dividing the product into individual components based on expected cost and manufacturing complexity implications. The detail-design phase provides accurate cost estimates and brings to the fore more decisions driven by manufacturing concerns. This scheme shows the main activities that characterize DFM.

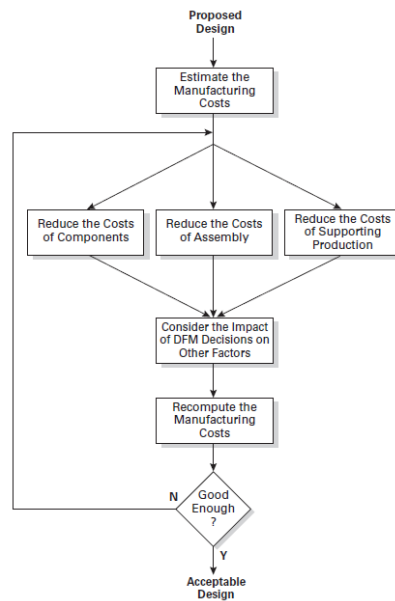

Figure 44 DFM steps [25]

1. **Estimate Manufacturing Costs:** Understand the cost of raw materials, purchased components, labor, energy, and equipment. Use unit manufacturing cost, which is the total manufacturing costs divided by the number of units produced in a period.

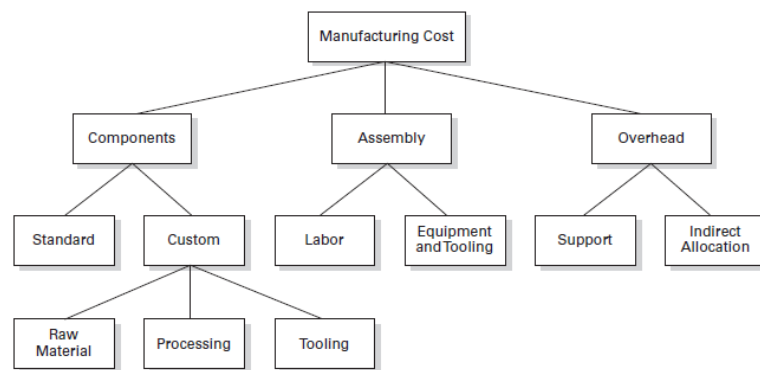

Figure 45 Manufacturing cost breakdown structure [25]

Taking in consideration the proposed scheme, here a framework that consider the main characteristic of each component of the manufacturing cost:

➤ **Component Costs:**

- **Standard Components:** Costs of standard parts are estimated by looking at every part to a comparable component which the company has already been creating or even purchasing in equivalent volumes or perhaps by soliciting price quotes from suppliers or vendors.
- **Custom Components:** These parts are manufactured by the manufacturer / supplier and are specifically created for the item. The cost is computed by adding the expenses of raw materials, tooling and processing together. In case the custom component is a combination of several parts, then it is regarded as a product in itself. the price of each

subcomponent, assembly, as well as overhead expenses are added up. Costs of tooling are the expenses for designing as well as fabrication of cutters, molds, dies and fixtures necessary to create components.

➤ **Assembly Costs:**

- For products made in quantities of less than several hundred thousand units per year, assembly is almost always performed manually. The manual assembly costs can be estimated by summing the estimated time of each assembly operation and multiplying by a labor rate.

➤ **Overhead Costs:**

- Overhead costs tend to be allocated using Overhead rates, also known as burden rates, which are usually applied to one or more cost drivers. These drivers are variables of the product which are directly measurable. A more accurate approach is activity-based costing (ABC) methods.
- Under ABC, the firm employs different and more cost drivers, and also allocates most indirect expenses where they fit best, to the associated cost drivers. This offers crucial insights for lowering overhead costs by concentrating on cost drivers.

➤ **Transportation Costs:**

- These expenses are incurred by transporting the completed products from the manufacturing site to the distribution site or the end user. The cost could be estimated based on regular shipping costs for the item, shipping expenses, etc. and must be considered if the physical weight or volume of the item is a design decision factor.

➤ **Fixed Costs vs Variable Costs:**

- **Fixed Costs:** Regardless the number of units of the product are produced, the expenses will likely be incurred in a predetermined amount.
- **Variable Costs:** The expenses tend to be incurred in direct proportion to the quantity of units manufactured.

➤ **The Bill of Materials (BOM):**

- The BOM is a listing of all elements of the product together with cost information. Simply by keeping the price estimates organized, it can help in manufacturing cost estimates..

2. **Reduce the cost of components:** For discrete goods, the cost of purchased components usually constitutes a significant part of the manufacturing cost. There are strategies to minimize these costs without the need for accurate cost estimates:

- **Understand Process Constraints and Cost Drivers:** It's vital to know the capabilities, cost drivers, and constraints of the production process to avoid specifying costly or unnecessary features. Sometimes, these can be communicated to designers in the form of design rules, like maximum part dimensions or allowable material types. When the cost of producing a part is tied to specific attributes, these are the cost drivers. For complex processes, collaboration with manufacturing experts can lead to cost-saving redesigns.

- **Redesign Components to Eliminate Processing Steps:** The production process can often be simplified by reviewing the design, which usually leads to

cost reduction. Parts could be created using a net-shape process, reducing the need for additional processing steps.

- **Choose the Appropriate Economic Scale for the Part Process:** Costs drop as production volume increases due to economies of scale. For each manufacturing process, fixed and variable costs exist. Processes with high fixed costs but low variable costs are better suited to high-volume production.
- **Standardize Components and Processes:** Standard components, common across different products, lead to lower unit costs and often better quality due to higher production volumes. Components can also be standardized within the same model.
- **Adhere to “Black Box” Component Procurement:** A strategy called black box supplier design allows a supplier to design a component based on what it needs to do, not how to achieve it. This hands the responsibility of design to the supplier, often leading to lower costs.

3. **Reduce the cost of assembly:** This particular phase is regarded as part of DFM, though it is considered an activity in its own right in some instances. DFA stands for Design for assembly and seeks to lower Assembly costs by lowering parts counts, production complexity as well as support costs. The DFA procedure consists of estimating the price of the assembly and analyzing assembly efficiency. In order to decrease this kind of cost, the authors suggest these strategies:

- **Integrate parts:** Regardless of whether a component is not deemed needed theoretically, it could be integrated with various other parts to decrease assembly costs as well as time. Part integration might not always be the most effective solution, though, since from time to time disintegrating parts are able to lead to savings in part production.
- **Maximize ease of assembly:** Assembly can be streamlined by utilizing parts that can be simple to assemble (such as the ones that don't require some tools, require just one hand for assembly, or are self aligning) and also by creating parts that can be simple to assemble.
- **Consider customer assembly:** Assembly expenses can be decreased and the item can be managed very easily if it's designed in such a manner so that customers can perform some assembly by themselves. Such a design, though, should allow it to be so that even the least competent of customers are able to assemble the item easily.

4. **Reduce the cost of supporting production:** This lowers the price of production and guarantees more efficiency and cost effectiveness. Because it is cost - associated and heavily associated with the previous strategies, all of the strategies that reduce it start with the review of them.

- **Minimizing Component and Assembly Costs:** Production costs could be decreased by simplifying the design, decreasing the number of parts and increasing the ease of assembly. This could indirectly lower costs associated with quality control, worker supervision, engineering assistance as well as inventory control.

- **Minimizing Systemic Complexity:** The manufacturing process often involves a wide range of suppliers, parts, people, products and production processes, each one because of its own complexity. This complexity could raise costs as a result of the need to inventory, manage, track, inspect as well as manage these variables. Organizations can bring down these costs by making smart design choices and lessening systemic complexity.
- **Error Proofing:** It is essential in the design stage to anticipate potential failure modes in the manufacturing process. Small differences between parts (like mirror parts or screws with different thread pitches) can lead to confusion as well as cause assembly mistakes. Here, strategies might include getting rid of these subtle differences or even exaggerating them (for example by color coding parts) for simpler differentiation as well as error proofing.

5. Consider the impact of DFM decisions on other factors: There are other factors which the DFM decisions have to consider that can impact the success of the product and also the company in general.

- **Development Time:** In the automobile industry, in which delays may lead to substantial financial loss, time is essential for product development. Although aiming for lowering costs, DFM decisions must not overly extend the development time. Complex parts call for more time to design and buy, which could result in delays. In dynamic markets, these delays might have cost advantages which outweigh the advantages.
- **Development Cost:** The development expense may be impacted by the complexity of the parts. Nevertheless, teams which are focused on cost reduction usually manage to develop products on time and within budget, compared to those who do not. Sound DFM techniques and excellent project management methods generally help to keep the balance.
- **Product Quality:** Assessing the effect of DFM decisions on the quality of the product. Initiatives to lower manufacturing costs should preferably also enhance the quality of the products created. A decrease in cost and weight, for instance, may be the result of a design modification, while simultaneously improving performance. Cost reduction strategies could, nevertheless, impact the quality of the product in some instances. When making DFM decisions, it is crucial that you take into account several dimensions of quality.
- **External Factors:** Decisions regarding DFM may have consequences referred to as externalities which go beyond one team or product. For example:
 - **Component Reuse:** Another team working on the same products may find it helpful to develop a low-cost component. These cross project cost ramifications in conventional manufacturing cost estimates might not be taken into account.
 - **Life Cycle Costs:** Costs incurred by products might not be included directly in the production cost analysis all through their life cycle. This includes costs associated with the product's environmental impact, warranty, and support. When making DFM choices, it's vital that you take into account such factors.

1.2.8 Product review:

A product review is not a separate task presented in Ulrich and Eppinger model. It is talked about, though, indirectly when talking about all corrective actions, from those in the level of the selection of product type shapes to the selection of suppliers and materials for bought parts.

Compared to the Mintzberg model, it can be placed between the *identification*, especially in support of the DFM phase, as well as the *development* of corrective maneuvers for the correct placing on the market and a model for the implementation of a strategy for the creation of a new product model. In general, the product review is going to cover all corrective steps taken right after the launch of the item.

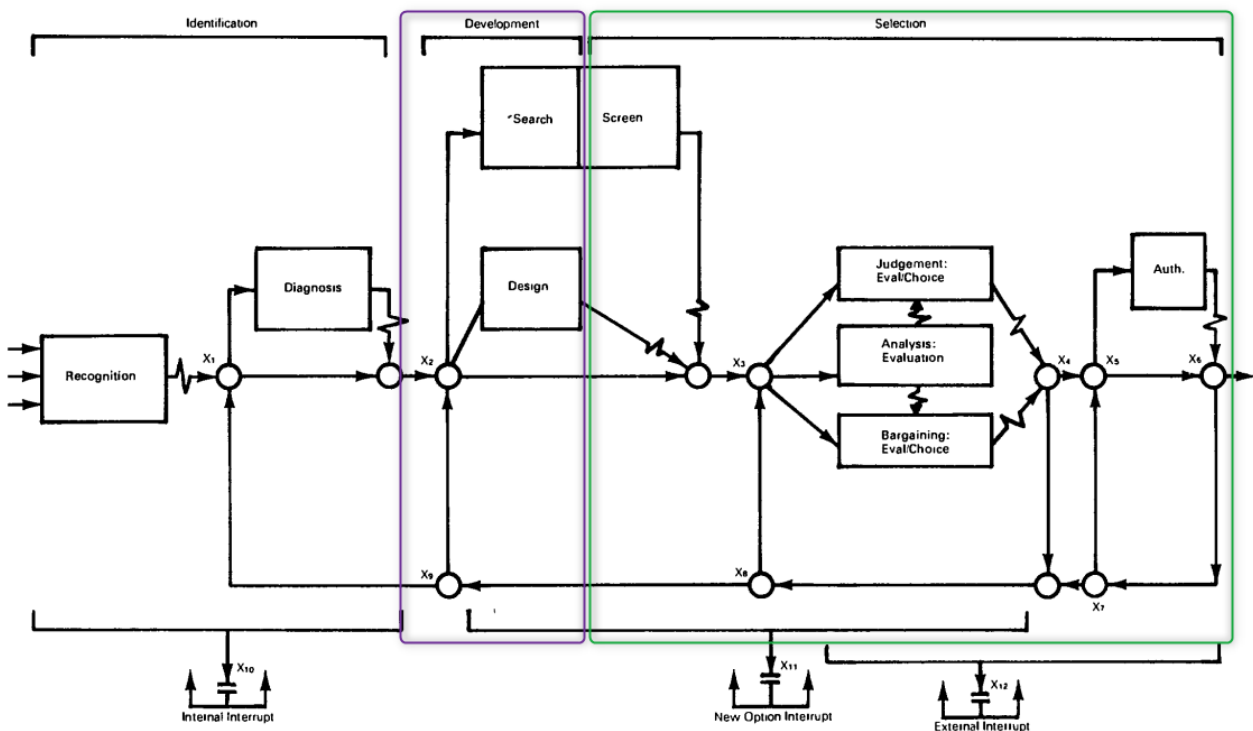

Figure 46 Mintzberg's decision process diagram

As far as the main decision-making problem-solving processes of this phase are concerned, action development classes are certainly predominant, precisely as a function of other activities as well as for the definition of action plans for the creation of a new model/product version..

This is the time when the organization rationalizes the development of the product on the marketplace and assesses the effect of the different decisions made on the success of the product itself throughout the product development stage. Consequently, it is here that the coding happens (if at all possible) as well as more generally the creation of knowledge created during the different product creation efforts. It is, thus, the foundation for brand new complementary product development cycles, but actually, it is very distinct, witnessed as well as thought from that which was talked about in the concept generation stage.

Because of the significance of environmental concerns in influencing customer choice, assessments are made in relation to the product life cycle, which typically contains the point where the item should be recycled and thrown away.

Consequently, it could be stated this phase includes the long-term view characteristic of even more strategic phases such as planning, but examines the way the strategically pertinent factors connect to phase choices at a far more design level. It must be pointed out that unlike the actual planning stage, the context where the team as well as organization work is a lot more structured here, because hypotheses and tests have been performed (even in the field) prior to achieving this stage, and also throughout the stage itself.

Following steps, this process could be summarized in general terms like follows :

Target Market Response Analysis: Understanding how the target market is going to react to a brand new product is crucial. This entails gathering and analyzing sales stats, engagement indicators, and client feedback. Surveys, social media monitoring, along with various other tools could all be utilized to get insight into the customer. This can reveal if the product lives up to customer expectations, the way it might be improved, and just how large the market may be.

Analyze the post-launch level of production and logistics: To maintain operational efficiency as well as economic well being of a company, it's crucial to. In the beginning, planning and production techniques are always based on estimates. These estimates are confirmed or not on the basis of the actual production trend, not only in terms of throughput, but also in terms of the physical dynamics of production.

Looking at the Economic Results After Launch: This entails evaluating the financial results of the product launch. This could include the price of goods sold (COGS), ROI, profitability, and the quantity of cash generated. The capability of the product to meet up with financial expectations could be determined by comparing these results to pre-launch forecasts, which may also assist with future resource allocation choices.

2 Artificial intelligence overview:

AI, or artificial intelligence, is a quickly changing industry with the aim of generating smart systems which are able to process data, reason, learn, and interact with their surroundings. It has fantastic potential, particularly in areas like product development where it can complement human abilities and automate tasks we previously believed were exclusively human.

AI concentrates on the replica as well as simulation of human intelligence, enabling machines to run independently or in concert with people. Among the building blocks of AI is knowledge representation - basically converting data to a format that computer systems are able to comprehend as well as analyze. This may be achieved in different ways for example symbolic representations, probabilistic as well as Bayesian networks, statistical visualizations and Markov models.

Computers require algorithms and methods to draw inferences, make choices and reach their objectives after knowledge is presented. The core of AI is this capability for knowledge-based reasoning and judgment. Yet another vital component is learning, which allows robots to pick up new awareness, adjust to changing circumstances, and also enhance their effectiveness in the long run.

The creation of models and algorithms which imitate the composition as well as operation of the human brain continues to be affected by cognitive neuroscience and scientific investigation. An AI technology is artificial neural networks that process and transmit data such as natural neural networks. Yet another illustration is deep learning, a kind of machine learning which builds hierarchical representations of data through layered neural networks, enabling computers to locate patterns and qualities in complicated, high dimensional information.

As AI develops, new approaches and methods are now being created for projects as well as applications ranging from computer vision to natural language processing to planning and robotics. The creation of innovative architectures as well as algorithms which can handle as well as learn from overwhelming volumes of unstructured data, in addition to the accessibility of substantial datasets, improved processing power, along with other elements, have all contributed to the expansion of AI.

Artificial intelligence (AI) could change product development processes by enhancing human abilities, automating mundane tasks and also providing insightful insights and forecasts that may guide decisions. Professionals might evaluate the potential of AI technologies and make educated choices about incorporating AI tools as well as approaches to their operations by having a solid grasp of the existing state of AI and its fundamental ideas.

Artificial intelligence (AI) is able to enhance design as well as innovation processes in the product development market by augmenting human capabilities, automating common tasks, and also providing related data and predictions that help in decision making. By taking a look at current state of the art in AI and its basics experts can assess the potential of AI technologies and make educated decisions regarding incorporating AI tools as well as strategies to their work.

2.1 Machine Learning

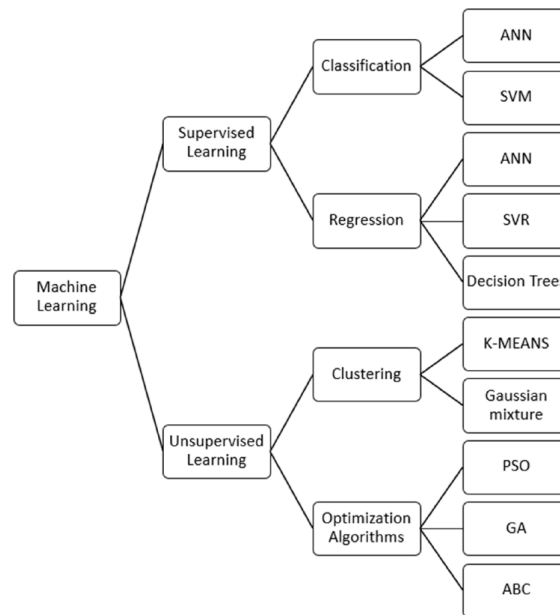
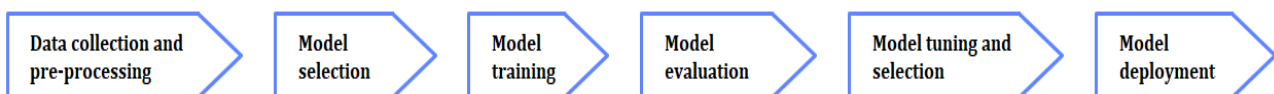

Figure 47 Types of ML [30]

A branch of artificial intelligence called "machine learning" creates models and algorithms that let computers learn from data and anticipate the future. It seeks to improve performance by strengthening underlying models through exposure to fresh information and knowledge. Several methods, including as supervised learning, unsupervised learning, reinforcement learning, and deep learning, employ mathematical and computational techniques like statistical analysis, optimization, and probability theory to create models that can be expanded from known instances to unknown data.

A six-phases process is the foundation of every machine learning technique:



When approximating complicated issues using simpler models, bias and variance are key considerations. Although a model should have little bias and little variance, these two qualities are sometimes compromised. Underfitting produces extremely low variance and high bias, whereas overfitting produces low bias and large variance. A technique called cross-validation divides the dataset into k equal-sized folds, trains the model on $k-1$ folds, and then tests the model on the last fold. This method is used to estimate model performance on unseen data. The model's performance estimate is the mean performance across all k iterations.

Various problems, such as image identification, natural language processing, game play, medical diagnosis, and financial modeling, have been tackled using machine learning. Systems that automate complicated processes, make data-driven judgments, and adapt to changing contexts have been created by researchers and practitioners.

For example, in A. Bertoni et al. [5] it is possible to find an immediate application of a supervised regression or surrogate model, thanks to which it was possible to carry out an investigation of the possible designs of a TRS, linked to the choice of a set of design parameters, also of a purely qualitative nature, such as those linked to the level of sustainability of the product. The machine learning model was useful in predicting fuel performance under operating conditions based on ICAO data, while it was able to build a maintenance cost model based on historical maintenance data. Indeed, databases that are as complete and dense as possible are fundamental to quality output.

2.1.1 Supervised Learning

A kind of machine learning called supervised learning utilizes labeled data to create predictions about unobserved data. It concentrates on building models that correctly forecast output variables from input information. The two primary subcategories of supervised learning algorithms are classification and regression. A potent yet straightforward approach for predicting continuous target variables based on input data is linear regression. In order to minimize the sum of squared discrepancies between actual target values and forecasted target values, it seeks to locate the straight line or hyperplane that fits the data the best. The equation below may be used to express the connection between input characteristics and goal variables:

$$y = b_0 + b_1x_1 + b_2x_2 + \dots + b_nx_n + e$$

Where:

- x_1, x_2, \dots, x_n are the input features,
- b_0, b_1, \dots, b_n are the coefficients (weights) to be learned and e is the residual (error) term.

OLS or gradient descent are both used in linear regression to estimate coefficients. Finding the best-fitting Sigmoid function for binary classification issues by predicting the likelihood of positive class occurrences is the goal of the linear regression variant known as logistic regression.

$$P(y = 1|x) = \frac{1}{1 + e^{-z}}$$

where:

- $P(y = 1 | x)$ is the probability of the instance belonging to the positive class
- $z = b_0 + b_1x_1 + b_2x_2 + \dots + b_nx_n$ (similar to the linear regression equation)

Maximum likelihood estimation and gradient descent are two techniques that may be used to train logistic regression models. A potent supervised learning technique for binary classification, Support Vector Machines (SVM) seeks the best hyperplane with the greatest margin between occurrences of two classes. The equation: represents the hyperplane.

$$wx + b = 0$$

where:

- \mathbf{w} is the weight vector
- \mathbf{x} is the input feature vector
- \mathbf{b} is the bias term

Using kernel functions like the Radial Basis Function (RBF) kernel, SVM may be extended to non-linear classification problems, enabling the learning of complicated decision boundaries in higher-dimensional spaces. Decision trees divide the input feature space into regions depending on feature values and are used for both classification and regression problems. Finding the best decision rules that reduce cost functions like Gini impurity or entropy for classification jobs or mean square error for regression tasks is the objective. To enhance performance and minimize overfitting, random forests integrate the predictions of many decision trees. Another technique used for both classification and regression problems is k-Nearest Neighbors (k-NN).

The forecast for the new data point is derived by taking the majority vote or averaging the target values of the k nearest neighbors. It discovers the k training examples that are closest to the new data point using a distance measure. Despite being straightforward and quick to use, the k-NN approach may be computationally costly, especially for big datasets. The algorithm's performance can be considerably impacted by the selection of the distance measure and hyperparameter k. Employing the strength of supervised learning algorithms, businesses may discover patterns, trends, and linkages that would not be obvious using conventional approaches, ultimately resulting in more creative and profitable goods.

2.1.2 Unsupervised Learning

Unsupervised learning is a branch of machine learning which concentrates on discovering structures and patterns in the data without using labels or predetermined results. It uses raw, unprocessed data to train models and discover hidden correlations and groupings. The goal is to reduce the dimensionality of the data, which will help with analysis as well as visualization. Principal component analysis (PCA) and t-distributed stochastic neighbor embedding (t-SNE) are two methods that can be utilized to reduce the dimensions of high dimensional data, while keeping their fundamental structure and relationships. PCA is able to determine the highest variance directions or axes in the data by calculating the eigenvectors and eigenvalues of the information covariance matrix.

$$X_{pca} = X_{centered}W$$

where $\mathbf{X}_{centered}$ is the mean-centered data, and \mathbf{W} is the matrix of eigenvectors sorted by their corresponding eigenvalues.

An unsupervised learning method called clustering divides data into groups based on similarity indices. A few well-liked methods include DBSCAN, hierarchical clustering, and k-means. Based on the data points' closeness to the cluster centroids, K-means allocates them to clusters and iteratively updates them until convergence.

The objective function for k-means is:

$$J = \sum_{j=1}^k \sum_{i=1}^n \|x_i^{(j)} - c_j\|^2$$

where J is the objective function, C_i is the i -th cluster, x_i is a data point, μ_j is the centroid of cluster j , and $\| \cdot \|$ denotes the Euclidean distance.

Using a technique called hierarchical clustering, layered relationships between data points and clusters are represented by a tree-like structure. Agglomerative or divisive techniques can be used, with the former creating each data point and the latter merging clusters based on similarity. Dividend-based hierarchical clustering begins with a large cluster and repeatedly breaks it up into smaller ones. Data noise may be managed and clusters of any shape can be found using the density-based clustering method DBSCAN.

2.1.3 Reinforcement Learning

A subfield of machine learning called reinforcement learning (RL) aims to create intelligent agents that interact with their environment to learn the best ways to make decisions. RL does not need explicit supervision using labeled data, in contrast to supervised and unsupervised learning. Instead, depending on their activities in the environment, agents learn through feedback, including rewards and punishments. Learning a strategy that maximizes the predicted cumulative reward over time is the aim of reinforcement learning.

RL must have the agent, the environment, the actions, the states, and the rewards. The agent changes the environment's state by acting in it, and is rewarded or penalized for this behavior. In order to maximize the cumulative reward over time, the agent seeks to acquire a policy. Exploration entails taking risks in order to learn more about one's surroundings and to improve one's comprehension of state-action-reward dynamics. Based on the agent's present information, exploitation entails choosing behaviors that are more likely to result in the highest benefits.

A mathematical framework known as the Markov Decision Process (MDP) is used to simulate decision-making issues in partially random and partially regulated contexts. It is described as a tuple (S, A, P, R) , where S is a finite collection of states, A is a finite set of actions, P is a function that measures the likelihood that a transition will occur, and R is a function that measures the rewards. Finding a policy that maps states to actions in order to maximize the predicted cumulative reward over time is the goal of an agent in an MDP.

This can be expressed mathematically using the concept of the value function, $V(s)$, which is the expected cumulative reward from following a policy π starting from state s :

$$V(s) = E \left[\sum_{t=0}^{\infty} \gamma^t R_a(s_t, s_{t+1}) \mid s_0 = s, \pi \right]$$

where γ is a discount factor ($0 \leq \gamma < 1$) that determines the relative importance of immediate versus future rewards, and E denotes the expectation.

Algorithms for reinforcement learning might be value-based, policy-based, or actor-critical. Value-based approaches, such as Q-learning and SARSA, concentrate on identifying the best value function for determining the best policy. In Q-learning, the cumulative benefits of performing actions and adhering to the best course of action are represented by an action-value function. The Q-learning update rule is given by:

$$Q(s, a) \leftarrow Q(s, a) + \alpha(R(s, a, s') + \gamma \max_{a'}(Qs', a') - Q(s, a))$$

where α is the learning rate ($0 < \alpha \leq 1$).

Deep reinforcement learning (DRL) algorithms, which can handle high-dimensional state and action spaces, complex settings, and large-scale issues, have been developed in recent years as a result of the integration of deep learning and reinforcement learning. Deep neural networks are used by DRL algorithms like Deep Q-Networks (DQN) and Proximal Policy Optimization (PPO) to represent the policy and/or value function, allowing the learning of intricate and sophisticated decision-making procedures.

Marcel Panzer & Benedict Bender [31] have carried out a thorough investigation of the applications of DQN, but more generally of reinforcement learning mechanisms. Their study shows how agents trained according to the logic of reinforcement learning manage to excel where normal heuristics fail, in terms of accuracy of operation, in the case of assembly, but also in terms of time/resource efficiency, as is instead emphasised for the application in production scheduling.

2.1.4 Deep Learning

A subset of machine learning known as deep learning builds and trains multilayer artificial neural networks (DNNs) to recognize hierarchical characteristics in unstructured data. This method has a big benefit over conventional ones since it can depict intricate patterns without the need for human feature engineering. Input, hidden, and output layers make up the network's architecture, and weights and biases control connections and output. Deep learning may learn intricate, non-linear patterns from input data by integrating these elements.

The following are typical steps of a deep learning process:

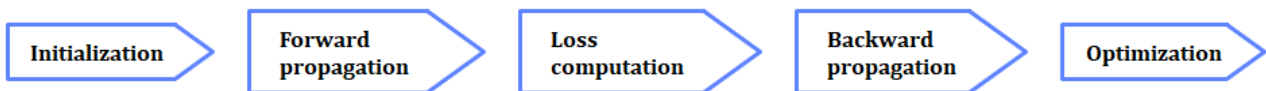

The forward propagation step is mathematically represented as follows:

Given an input vector x , the output of the first hidden layer (h_1) can be computed as:

$$h_1 = f(W_1x + b_1)$$

where \mathbf{W}_1 is the weight matrix connecting the input layer to the first hidden layer, \mathbf{b}_1 is the bias vector for the first hidden layer, and \mathbf{f} is the activation function (e.g., ReLU, sigmoid, or tanh).

Similarly, the output of the second hidden layer (h_2) can be computed as:

$$h_2 = f(W_2h_1 + b_2)$$

This process continues until the output layer is reached, which computes the final output \mathbf{y} :

$$y = f(W_Lh_{L-1} + b_L)$$

where \mathbf{L} is the number of layers in the network.

The backpropagation step involves computing the gradients of the loss function with respect to the weights and biases. For example, the gradient of the loss function J with respect to the weight matrix W_1 can be computed as:

$$\nabla_{W_1} J = \frac{\partial J}{\partial W_1}$$

These gradients are then used to update the weights and biases using the chosen optimization algorithm.

By learning intricate, hierarchical representations from unstructured data, deep learning has transformed a number of activities. The Convolutional Neural Network (CNN), which analyzes grid-like data like pictures using a number of convolutional layers, pooling layers, and fully linked layers, is its most well-known design. When convolutional procedures are applied to the input data, local patterns and features are learned while maintaining spatial connections. While fully linked layers generate the final result, pooling layers lower the spatial dimensions. The Recurrent Neural Network (RNN) is made to analyze data sequences, such time series or text written in natural language.

RNNs are beneficial for applications such as time series prediction, sentiment analysis and language modeling, because they contain recurrent layers which store and recall information from earlier time steps. Learning from long sequences can be difficult because RNNs have to deal with problems such as vanishing and bursting gradients. These problems were addressed by the creation of advanced RNN designs, such as Long Short-Term Memory (LSTM) and Gated Recurrent Unit (GRU).

Deep learning mechanisms are often used in the field of structural mechanics, and more specifically in topology optimisation, as they are able to reduce the computational burden associated with the resolution of mathematical systems that reflect the behaviour of objects of a given nature subjected to a given set of stresses. This is defined in numerous articles in the literature, and in particular Kalliotras et al. show how they can be integrated with methods and approaches for solving structural problems, in particular Solid Isotropic Material with Penalization (SIMP), both for defining whole classes of designs that respond positively to initial requirements [33] and for optimising the process to arrive at a single acceptable design [32]. Such tools are now integrated with those of the CAE type and are of fundamental help, especially in the detailed or embodiment design phases, but potentially they can also be used in the concept design phases to generate rudimentary models, where the constraints defining the problem are set as a first approximation.

In Zhu et al [34], deep learning methods are also used to predict the temperature and melt pool dynamics during metal additive manufacturing process, given a moderate amount of labeled data-sets. Physical principles and pure data were combined in order to develop an architecture called PINN (physical-informed neural network) capable of integrating the statistical efficiency of machine learning and the knowledge of physic principles. In this particular case, the problem was not defined by structural laws, but thermal fluid and heat transfer equations. In this case the main input are AM parameters, material properties and location of interest for the analysis, but the mathematical representation of the problem and the output quality are similar to the previous cases. About the latter, with relatively small

amount of data it was possible to accurately define output, such as the melt pool length, and compare it to real life measurement.

2.1.5 Generative Models: Generative Adversarial Networks (GANs) and Variational Autoencoders (VAEs)

Generative Adversarial Networks (GANs) are a type of AI model that can generate new data instances that resemble the input data. Two neural networks play a 'game' where the generative network creates new instances, and the discriminative network evaluates their authenticity, i.e., whether they are from the original dataset or were generated. GANs have seen extensive use in image creation and modification and even more complex applications like drug discovery. They represent an exciting frontier of AI that can enhance product development, creating innovative solutions for complex problems.

Variational Autoencoders (VAEs) are another type of generative model that uses the principles of autoencoders and introduces a probabilistic spin on the latent representation. They can generate synthetic data that are similar to the input data, proving valuable in a variety of applications, from anomaly detection to synthetic biomedical data generation. The ability of VAEs to exert a level of control over the generated instances brings a new level of sophistication to the AI landscape, offering opportunities for product development and innovation.

These can be used across several phases of product development and in different industries, from aeronautics, to define the best aerodynamic shape of a wing [35], to animation, where image generation is used to automate the creation of short films and movies.

2.3 Evolutionary Computation

A subfield of artificial intelligence known as evolutionary computation uses the concepts of crossover, mutation, and the survival of the fittest to iteratively optimize difficult problems. In order to identify the best solutions within a problem space, genetic algorithms (GAs), a common type of GA, combine the selection, crossover, and mutation operators.

2.3.1 Genetic Algorithms

Natural selection and evolution-based genetic algorithms efficiently look for superior solutions while preserving population variety. They are appropriate for product development optimization issues like design parameter optimization. They investigate several design possibilities iteratively evolving candidate solutions until settling on nearly ideal solutions that satisfy the required goals and restrictions.

These are the main steps that characterize a genetic algorithm.

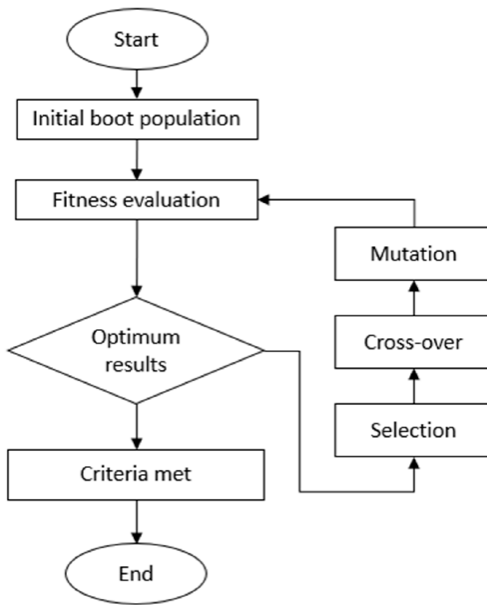

Figure 48 Generic Genetic algorithms steps [30]

- *Encoding*: In a genetic algorithm, the first step is to describe the potential solutions as a data structure, frequently referred to as a chromosome.
- *Initialization*: The restrictions of the problem are taken into account as a population of potential solutions (chromosomes) is produced arbitrarily or via a heuristic method.
- *Fitness Evaluation*: Each candidate solution in the population is graded according to its fitness using a fitness function. The fitness function assesses how well a solution satisfies the optimization goals and is problem-specific.
- *Selection*: Based on their fitness values, the selection operator selects a portion of the population for reproduction. The likelihood that a candidate solution will be chosen increases with its fitness value. Rank-based selection, tournament selection, and roulette wheel selection are examples of common selection methods.

- *Crossover*: In order to produce child solutions, the crossover operator integrates the genetic material of two or more parent solutions. Depending on how the chromosomes are represented, many crossover methods exist. One-point, two-point, and uniform crossover are popular techniques for binary strings.
- *Mutation*: Through the addition of random modifications to offspring solutions, the mutation operator maintains population diversity and prevents early convergence. Mutation techniques vary depending on how the chromosome is represented, using bit-flip for binary strings and Gaussian or polynomial for real-valued vectors.
- *Replacement*: The population's offspring solutions are incorporated either by generational replacement of the entire population or steady-state replacement of a subset of the least fit individuals.
- *Termination*: Until a termination requirement, such as a maximum number of generations, a goal fitness value, or a lack of improvement in the best solution, is met, the algorithm iterates through stages 3 through 7 of the method.

2.4 Computer Vision

A branch of artificial intelligence called computer vision aims to develop computer programs that can analyze and comprehend visual data. It entails creating algorithms and methods to interpret, process, and make sense of pictures and videos, allowing computers to carry out activities that ordinarily call for human vision. Using mathematical models and computational methods like convolutional neural networks and fully convolutional networks, computer vision aims to mimic human visual perception.

Applications for product development include visual inspection, automated quality control, and flaw identification. By comparing photos of manufactured goods with reference images of defect-free products, computer vision algorithms may detect manufacturing flaws, increasing production efficiency and guaranteeing consistent product quality. The usage of computer

vision in augmented reality (AR) can also be used to view and assess product designs in actual environments. This enables designers to make deft decisions and spot potential design problems at an early stage of the development process.

The study of consumer behavior and market trends can also make use of computer vision techniques. Computer vision algorithms can gain important insights into consumer preferences, new trends, and prospective areas for product innovation by examining visual data from social media platforms, product evaluations, and online forums. In order to improve designs and maximize them for both beauty and utility, a corporation could, for instance, employ computer vision techniques to examine photos of furniture and discover crucial design components, such as color schemes, materials, and shapes. Computer vision can also be used to model how furniture would look in various settings, enabling businesses to make necessary alterations.

2.4.1 Object recognition

A key component of computer vision is object recognition, which involves identifying and categorizing items in pictures and videos. Its main objective is to identify the classification or group of a certain item. Convolutional neural networks (CNNs), which have fully connected, pooling, and convolutional layers, are used to recognize objects. Fully connected layers classify input based on retrieved characteristics, pooling layers reduce spatial dimensions, and convolutional layers extract local information.

2.4.2 Image Understanding

In order to perform tasks like scene identification and comprehending object relationships, image understanding focuses on extracting semantic information from images or videos. Its fundamental objective is to offer thorough interpretation of visual information to support decision-making and problem-solving across a range of applications. A popular technique is semantic segmentation, which creates a classification map by giving class labels to each pixel in the image. In order to provide spatial output with the same dimensions as the input image, completely convolutional networks (FCNs), which swap fully connected layers for convolutional layers, are also employed for semantic segmentation.

2.5 Robotics

Engineering, computer science, and other disciplines are combined in the multidisciplinary field of robotics to design, create, and control robots. These programmed machines are capable of interacting with the real environment, carrying out difficult tasks, and acting autonomously or partially autonomously. Robotics helps design and innovation processes in product development, improves production and assembly capabilities, and produces new goods. Robots can simplify tedious operations, increase production speed, and offer useful insights and feedback during the design and prototype phases by combining cognitive control and autonomous exploration.

2.5.1 Intelligent Control

Robot behavior and activities are controlled utilizing sophisticated computational methods and algorithms, allowing them to adapt to changing situations. This is accomplished by combining conventional control techniques like feedback control, feedforward control, and model predictive control with artificial intelligence tools like neural networks, machine learning, and evolutionary computation. Reinforcement learning (RL) is a popular strategy

where a decision-making agent learns by interacting with the environment and receiving feedback in the form of rewards or penalties.

By choosing the best course of action in each state, the objective is to maximize cumulative reward over time. RL can be formalized using the Markov Decision Process (MDP) framework, where S stands for potential states, A for potential actions, P for the likelihood of a state change, and R for the anticipated immediate reward. The agent aims to discover a policy that maximizes the value function, often known as the expected cumulative reward.

2.5.2 Autonomous Exploration

In particular, robotics is founded on the capability to explore environments autonomously and communicate with them with no human intervention. This particular capacity is important for robots operating in unstructured or unpredictable conditions, for instance during search as well as recovery missions, space exploration or product development, where robots are continuously adapting to changing conditions.

The autonomous exploration of the robot is essential since it detects its surroundings. This is possible because a number of sensors, such as accelerometers, cameras, Ultrasonic sensors and lidar sensors, collect data about the robot's environment. The input is then examined using computer vision, machine learning, along with other AI methods to produce an environment representation like a 3D version or a chart that the robot is able to utilize to prepare its actions and movements. A common technique of autonomous exploration would be the Simultaneous Localization and Mapping (SLAM) technique, which oftentimes allows for a robot to make a map of its environment very slowly while estimating its influence on the map.

2.6 Expert Systems

Expert systems is a subfield of artificial intelligence which specializes in creating computer programs which imitate the judgment abilities of human beings in certain areas. These systems make their decisions and choices based on the knowledge they get from a knowledge base comprised of facts as well as rules. Expert systems may be used in a variety of areas, from engineering as well as product development to finance and healthcare, such as decision support systems as well as education systems.

2.6.1 Decision Support Systems

Decision support systems (DSS) are expert systems that provide users with pertinent data and analysis to aid in decision-making. DSSs aid project managers, designers, and engineers in product development by evaluating design options, analyzing risks, and streamlining procedures. The knowledge base, the inference engine, and the user interface make up their three primary parts. In order to reason and make judgments, the knowledge base comprises domain-specific facts, rules, and connections. The knowledge base may be represented using methods like production rules, frames, and semantic networks, which enables a straightforward if-then statement to indicate the connection between facts and deeds.

The inference engine applies information to specific examples of a problem while forming inferences and conclusions. In order to provide solutions, it employs both forward chaining and backward chaining algorithms. Backward chaining looks for facts and production rules that support the aim whereas forward chaining starts with facts and applies them till a goal is

achieved. User engagement with the DSS depends heavily on the user interface, which can range from straightforward text-based to complex graphical interfaces.

2.6.2 Teaching Systems

Intelligent tutoring systems, commonly referred to as instructional software, give students individualized training and direction in certain academic areas. These systems simulate the learner's subject-matter expertise and instructional approaches using AI techniques including natural language processing, machine learning, and knowledge representation. These systems may help experts like designers, engineers, and architects with a variety of tasks related to the development process, such as choosing materials, improving designs, and choosing production techniques. The user interface, the student model, the tutoring model, and the domain model are the four essential parts of a teaching system. While the student model provides the learner's current knowledge, abilities, and comprehension, the domain model describes the subject matter knowledge.

The tutoring approach incorporates pedagogical knowledge and tactics including scaffolding, questioning, and elaboration to give suitable teaching strategies and feedback depending on the domain and student models. Like decision support systems, the user interface enables students to engage with educational materials, submit data into the teaching system, and get feedback.

2.7 Speech Processing

A branch of artificial intelligence called speech processing studies, synthesizes, and comprehends human speech. It makes it possible for machines to comprehend and produce spoken language, improving interaction between AI systems and people. Speech recognition, speech synthesis, and speaker identification are the three primary components of speech processing.

2.7.1 Speech Recognition

Automatic speech recognition (ASR), commonly referred to as speech recognition, uses mathematical models and algorithms to translate spoken words into written representations. The link between speech acoustic characteristics and linguistic units is represented by the Hidden Markov Model (HMM), a common approach in automatic speech recognition. HMMs are appropriate for ASR because they can represent time-varying processes and take into account data ambiguities and variability. HMMs may faithfully capture the underlying language units in speech signals by predicting the most probable sequence of linguistic units.



2.7.2 Speech Synthesis

Text to speech (TTS), commonly referred to as speech synthesis, is the technique of producing spoken words from written input. The goal of TTS systems is to produce comprehensible, natural-sounding speech that closely approaches human speech patterns. Concatenative synthesis, parametric synthesis, and neural network-based systems like Tacotron and WaveNet are examples of typical techniques. Utilizing a vast library of recorded speech units, concatenative synthesis entails putting together segments of recorded speech. Using

mathematical models, parametric synthesis creates speech sounds depending on input parameters including frequency, duration, and spectral envelope.

A stack of dilated CNN layers are used by the generative model WaveNet to record the temporal relationships in the spoken stream. By converting textual input into spectrograms that show the frequency content of the speech signal over time, Tacotron, an end-to-end TTS system, can translate speech. These spectrograms may be transformed into raw voice waveforms using a vocoder like the Griffin-Lim method or WaveNet. Tacotron can generate speech signals with acoustic characteristics and prosody similar to human voice by training the model on a significant amount of text and speech data.

2.7.3 Speaker Identification

The method of identifying a speaker based on their speech characteristics is known as speaker identification, and it may be beneficial in applications such as voice biometrics, personal assistants, and audio indexing. Pitch, formant frequencies, and spectral envelope are just a few of the distinguishing aspects that speaker identification algorithms extract from voice data to reflect the speaker's individual vocal characteristics. A technique that is frequently used is the Gaussian Mixture Model-Universal Background Model (GMM-UBM) architecture, which was trained on a sizable dataset of speech signals from several speakers. Using voice data from the target speaker, a speaker-specific GMM is created from the UBM, capturing the distinctive qualities while preserving the UBM's overall structure. The system assesses the probability of observed acoustic characteristics under the speaker-specific GMM and the UBM, and bases its choice on the ratio of likelihoods, when faced with an unknown speech signal.

In order to acquire more sophisticated and discriminative representations of speaker-specific information, deep learning has also been used in speaker identification systems. Large-scale datasets may be used to train these models to pick up on minute differences in sound quality, leading to more precise and reliable speaker recognition performance.

2.8 Natural Language Processing

A technique of determining a speaker based upon their speech characteristics is referred to as speaker identification and might be helpful in applications including sound indexing, personal assistants, and speech biometrics. Pitch, formant frequencies as well as the spectral envelope are merely some of the distinguishing features which speaker identification algorithms extract from audio information to mirror the individual vocal attributes of the speaker. A method which is often used will be the Gaussian Mixture Model -- general Background Model (GMM-UBM) architecture trained on a large set of speech signals from a number of speakers. A speaker-specific GMM is produced out of the UBM utilizing voice details from the target speaker, recording the unique characteristics of the UBM while keeping the general structure of the UBM.

The tokenization which constitutes the foundation for virtually all NLP activities is the division of a text into specific words or even tokens. Individual text tokens are recognized as part of speech (POS) tags and may be utilized for an assortment of NLP functions such as sentiment analysis, named entity identification and parsing. To parse a sentence, its grammatical framework should be investigated along with a parse tree which mirrors its syntactic relations must be produced.

In a high dimensional vector space, word embeddings are mathematical representations of words that communicate semantic connections and qualities. These representations are created by training a neural network on large corpora of text data using unsupervised machine learning techniques like Word2Vec, GloVe, and FastText.

Sequence-to-Sequence For applications like machine translation, text summarization, and speech recognition that require mapping input sequences to output sequences, models are deep learning architectures.

Transformer models are a new development in NLP that effectively handle and interpret long-range relationships in natural language data by using the self-attention mechanism. These models may capture complex links and dependencies between words and phrases by dynamically focusing on different positions across the input sequence while analyzing every location.

By combining the powerful representational capabilities of the transformer architecture with enormous quantities of pre-training data, the BERT (Bidirectional Encoder Representations from Transformers) model, for instance, has produced ground-breaking results on various NLP benchmarks.

2.9 Planning

AI, or artificial intelligence, is a quickly changing market with the aim of generating smart systems which can process data, learn, reason, and interact with their environment. It has wonderful potential, particularly in areas like product development where it can complement human abilities and automate tasks we previously believed were exclusively human.

AI concentrates on the replica in addition to simulation of human intelligence, enabling machines to run independently and in concert with individuals. One of the building blocks of AI is knowledge representation - essentially transforming data to a format which computer systems can understand and analyze. This might be accomplished in different ways for instance symbolic representations, probabilistic in addition to Bayesian networks, statistical visualizations and Markov models.

Computers require algorithms and techniques to draw inferences, make choices and reach their objectives after knowledge is presented. The core of AI is this ability for knowledge based reasoning and judgement. One more essential part is learning, which enables robots to acquire brand new awareness, adjust to changing conditions, and also enhance their usefulness in the long term.

The creation of models and algorithms which imitate the composition as well as operation of the human brain continues to be impacted by cognitive neuroscience and scientific investigation. An AI technology is artificial neural networks that process and transmit data such as natural neural networks. Another illustration is deep learning, a kind of machine learning which builds hierarchical representations of data through layered neural networks, enabling computers to locate patterns and qualities in complicated, high dimensional information.

As AI develops, new methodologies and approaches are now being created for projects and applications spanning computer vision to natural language processing to planning to robotics. The creation of innovative architectures in addition to algorithms which could manage and

learn from overwhelming volumes of unstructured data, along with the accessibility of sizable datasets, enhanced processing power, together with other components, have all contributed to the expansion of AI.

Artificial intelligence (AI) could alter product development processes by improving human abilities, automating mundane tasks and also offering insightful insights and forecasts that may guide decisions. Professionals might evaluate the potential of AI technologies and make educated choices about incorporating AI tools as well as strategies to their operations by having a solid grasp of the existing state of AI along with its basic ideas.

The application of artificial intelligence (AI) in the product development market can enhance design and innovation processes by improving human capabilities, automating typical tasks, providing relevant data and predictions which help in decision making. By looking at current state of the art in AI and its basics experts can look at the potential of AI technologies and make informed decisions concerning incorporating AI tools and strategies for their job.

2.9.1 Scheduling

Scheduling, which focuses on resource allocation and job sequencing to accomplish certain goals within a set time period, is a critical component of AI planning. A well-structured workflow, efficient resource use, and timely job completion are all made possible by effective scheduling. Single-machine scheduling, parallel-machine scheduling, flow-shop scheduling, and job-shop scheduling are some of the several categories that scheduling issues might fall under.

Linear programming, integer programming, and dynamic programming are three mathematical methods for approaching scheduling. For instance, integer linear programming (ILP), which tries to reduce the time it takes for the final job to be completed, can be used to represent the single-machine scheduling problem.

Particle swarm optimization (PSO), simulated annealing, and genetic algorithms are three AI-based techniques that have demonstrated tremendous promise for resolving complicated scheduling issues by efficiently exploring the solution space and delivering close to optimum results in a reasonable amount of time. Simulated annealing (SA), another metaheuristic algorithm inspired by metallurgical annealing, is a population-based optimization approach that draws inspiration from genetics and natural selection. Local search movements are used by SA to iteratively explore the solution space after starting with an initial solution. A population-based optimization approach called PSO, where each particle in the swarm is initially given a random position and velocity, was inspired by the behavior of fish schools or flocks of birds. The particles update their locations and velocities after each iteration using both their individual best solutions and the swarm's collective best solution. Through collective learning, this technique enables the swarm to converge towards an ideal or nearly ideal solution.

2.10 Large Language Models

Huge language models, like GPT-4, have drawn interest for their capability to create written text that resembles human speech, carry out intricate tasks, and assist artistic pursuits. These models can recognize statistical patterns and grammatical structures unique to human language due to their deep learning foundation and extensive training on data from textual content. They could be utilized to accelerate innovation and accelerate processes at different

phases of product development, which includes concept generation, idea development, and marketing.

The transformer architecture is a sort of neural network created especially for handling sequence-to-sequence tasks, such machine translation or text synthesis, according to Vaswani et al. The self-attention mechanism along with also the position - wise feed - forward networks make up its important elements. The position-wise feed-forward networks include 2 completely connected layers with a main ReLU activation function along with a self-attention mechanism which enables the model to evaluate the relative value of every word in sequence to the other words.

Unsupervised learning methods are utilized for training large language models, particularly masked language modeling, which asks the model to anticipate hidden phrases based on the context that the surrounding words offer. A model of a big language is as small or large as its constituent factors, which directly impacts its ability to effectively represent complex linguistic patterns and relationships.

Huge language models can be utilized at various points of the NPD to encourage innovation and boost productivity. Idea creation, market analysis, concept development, along with marketing and communications are some examples. They might occasionally produce content that is understandable but contradictory or erroneous factually, and they could also reinforce some biases existing in their training data.

Performance evaluation is crucial for big language models to be helpful in product design. Assessment measures generally include perplexity, the BLEU (Bilingual Evaluation Understudy) score, or the ROUGE (Recall-oriented Understudy for Gisting evaluation) rating. These metrics help product development teams in analyzing the dependability and quality of extensive language models, ensuring their responsible and efficient inclusion into product development.

Large language models' possible uses in product development are anticipated increasing as they develop and get much better. Future advancements include personalisation, interaction with other AI systems, and improved interpretability and explainability.

3 AI-supported decision-making processes in product development:

In Chapter 1, we proposed a reference model that encapsulates a multitude of activities varying in specificity. These activities are performed following specific logics and pursuing specific objectives, which emerge from the necessity to mitigate as much uncertainty as possible. Within this model, we can pinpoint common elements and characteristics that influence decision-making processes, rather than the way the activities are executed. In other words, the focus here shifts to the act of creating an action plan for conducting the different activities.

Contrary to previous considerations where an operational and atomic approach was adopted, focusing on classical tools and methods that guide the execution of each phase, here we pivot the reasoning. The spotlight now falls on the generalization of decision making problem situations that are common throughout the product development process, forming the foundation upon which an analyst bases their decisions.

Therefore, drawing on the approach defined by Norese and Ostanello (1988) [45], each of the level 3 phases is first associated with a principal context of action (CoA). These CoA are the recurrent sub-processes carried out by a group or and individual decision-maker agent. The contexts associated with the phases examined in the Chapter 1 model are mainly four and are defined as follows:

- **Identification (ID)** refers to understanding the nature of decision-making problems within the organization that generates them and the potential operational strategies that can be utilized. In mainly involves identifying the existing information and knowledge elements, from inside and outside the organization, that are significant and applicable to the situation at hand.
- **Structuring (STR)** pertains to the process of organizing the decision-making problem, information, and knowledge elements into a coherent layout. Structuring provides a solid framework which guides the subsequent stages of product development and ensures a more systematic and efficient approach to solving the problem.
- **Control (CNTR)** encompasses the management and verification of the decision-making process. This includes evaluating and validating each output produced, whether they are partial or complete, temporary or final, cognitive or organizational. In product development, control mechanisms ensure that the process is progressing as planned, that the quality of the product meets the required standards, and that any deviations or issues are promptly identified and addressed.
- **Development (DEV)** involves the creation of feasible actions, models, and applications of methods and procedures for problem-solving. In product development, this is where the actual product is designed, built, and tested based on the outcomes from the identification and structuring stages.

A further crucial Context of Action (CoA), that was not overtly integrated into the initial reference model, is that of Communication (Com). This context assumes paramount importance owing to its broad role in recognizing and engaging all the key stakeholders and actors intricately woven into the decision-making process. Consequently, it earns the distinction of being the most universally applicable CoA.

- **Communication (COM)** is the ongoing interaction with the problem owner, stakeholders, and information sources, both at the individual and organizational levels. In the context of product development, this could involve regular updates with stakeholders, feedback sessions with test users, and open channels with suppliers or other external parties. Communication is essential in both individual and group decision-making contexts as it ensures transparency, enhances collaboration, and facilitates a more holistic approach to product development.

The initial transition from the level 3 phases to the primary Contexts of Action (CoAs) is examined in paragraph 3.1. This section accentuates and explicates the main reference CoAs associated with the various level 3 phases. Analogously, paragraph 3.2 explores the connection between the principal Artificial Intelligences (AIs) and each of the CoAs, focusing on the components that define and necessarily characterize them, even from a functional standpoint. As a result, a compact reference map is created that harmonizes the complexity of decision-making processes intrinsic to product development procedures with the perpetually evolving capabilities of AI.

Overall, the development of this reference map fosters a more systematic and structured approach to product development, one that accounts for the complexity of decision-making processes and the burgeoning capabilities of AI. This approach underscores the transformative potential of AI in product development, underlining how it can streamline decision-making processes, enhance efficiency, and ultimately drive superior outcomes.

The essence of the reference map lies in its ability to capture the multifaceted relationships between different stages of product development, their corresponding Contexts of Action, and the intertwined nature of Artificial Intelligence. It encapsulates the complex dance between decision-making processes and evolving AI capabilities in a simplified, visual form. Yet, its purpose is not merely to clarify the present state of affairs; it is meant to guide the trajectory of future research, to stimulate new questions, to reveal unforeseen correlations, and to encourage exploration beyond the known territories. Thus, the reference map/table is the starting point of a journey rather than its destination

Here it is proposed a schematic description of the process used to produce the said table:

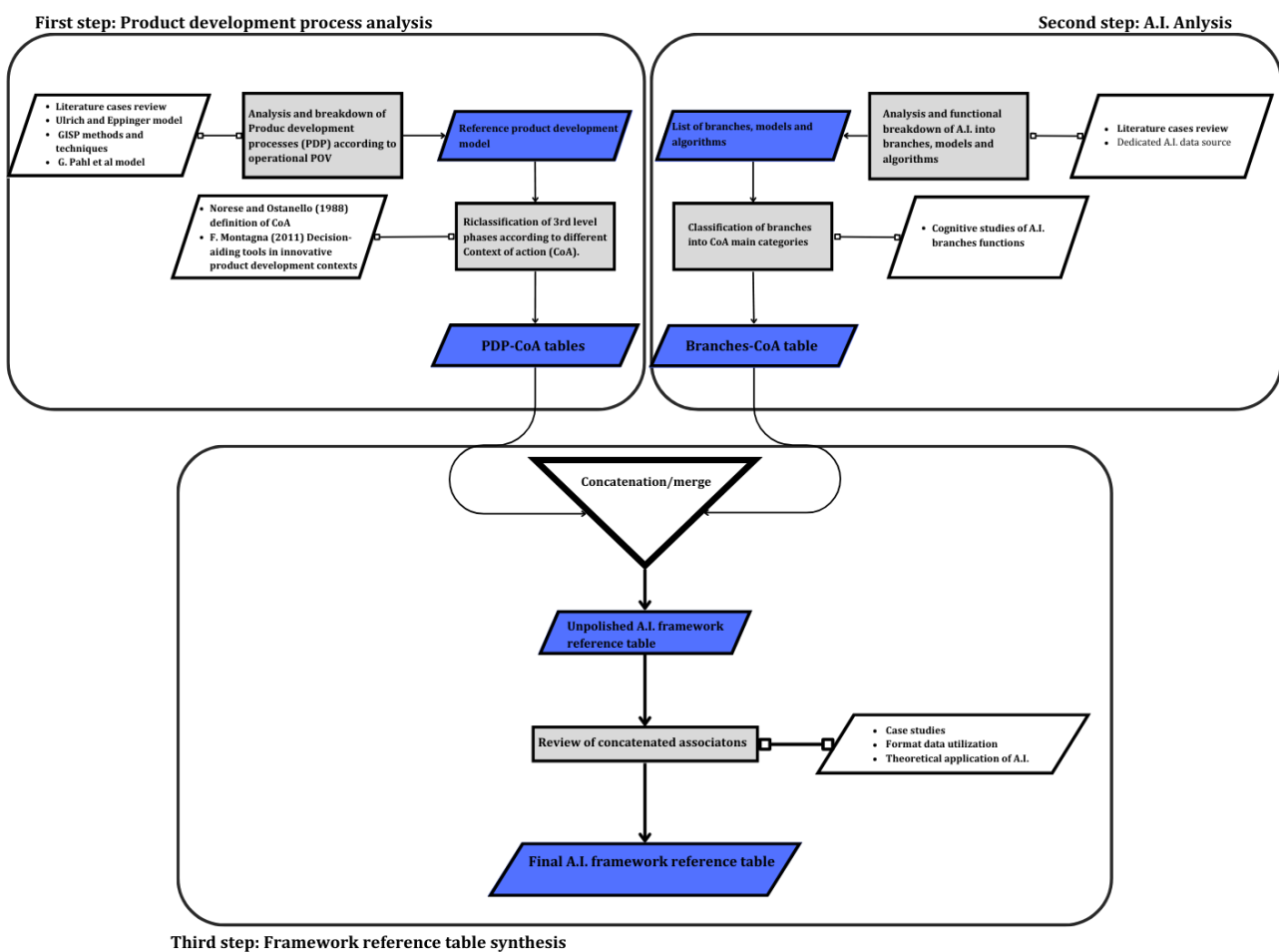

3.1 CoA in Product development process model:

In this particular section, an exploration is conducted wherein the individual phases of level 3 are selected and categorized in conjunction with the main Context of Action (CoA) to which they are most relevant. This approach not only deepens the understanding of each phase, but also clarifies the type of knowledge and objectives that each phase is capable of generating and aiming.

3.1.1 Identification:

Lvl 1 Phase	Lvl 3 Phase	Research objective
PL	Technological data gathering	New technologies
PL	Legal and regulatory data gathering	Law norms
PL	Market data gathering	Competitive landscape
PL	Gathering raw data from customer	Customers' preferences
CD	Search externally	Valid design solutions
DD	Relevant manufacturing variable definition	Usable manufacturing variables
PR	Gathering raw data from customer feedbacks and sales	Target market response
PR	Gathering raw data from complete production system	Actual capabilities of the production system

It is easy to see that identification CoA is dominant in the planning phase. The phase of planning inherently aligns with decision-making scenarios wherein concrete objectives are yet to be defined. These undefined objectives can be of strategic and organisational nature, manifesting for example as sales targets, target awareness, Expected commercial value (ECV), Time to Market (TTM), or more technical and practical nature, and therefore be exemplified by parameters like Ideal target specification value or Cost of Goods Sold (COGS). This high level of uncertainty is in fact typical of the beginning of a new product development process, when is particularly difficult to conduct an analysis without having first defined and populated a reference information base. In fact, this is the primary purpose of identification, to generate a knowledge base, heterogeneous but profound, to be used to carry out reasoning and inference, through which to face strategic choices, to generate alternatives, directions, if not to recognize and exploit otherwise invisible opportunities.

3.1.2 Structuring:

In this paragraph the principal level 3 phases that are enabled in the Structuring Context of Action are listed in the table below. The goal guiding the structuring process was also defined alongside each of them.

LvL 1 Phase	Lvl 3 Phase	Structuring goal
PL	Global strategy and Innovative charter definition	Acquisition of global direction of the entire process
PL	Scheduling of project activities and resource allocation	Acquisition of technology strategy and readiness
PL	Reduce and hierarchize customer needs	Relevant needs appearance
CD	Prepare a list of metrics	Definition link needs-specifications and informative elements for development and evaluation model
CD	Clarify the problem	Definition of problem dimensions
CD	Concept scoring	Ranking alternatives
SD	Cluster the elements of the schematic	Definition of relevant problem in the system configuration
DD	Deep analysis of the link component/subsystems - architecture	Definition of problem dimensions
PR	Evaluation of customer feedbacks	Definition of unsatisfied customer needs and unexpected customers' expectations

In parallel with what arise in the previous paragraph, here is it possible to detect the prevalence of the planning activities in the structuring context of action. This is logically plausible since in order to better define (and thus structure) a decision-making process/situation is fundamental to elaborate and analyze those data acquired in the identification context. In fact, it is not possible to generate a decision-making action plan if no order has been given and therefore no rule has been applied to classify and re-order the accumulated information base.

However, unlike the previous case, there is no overwhelming concentration of phase activities belonging to the same macro category, thus tools that are capable of mimicking the structuring processes can easily be applied to almost the entirety of the product development process.

3.1.3 Control:

This paragraph considers the recurrency of Control Context of Action in the entire product development model proposed.

Lvl 1 Phase	Lvl 3 Phase	Evaluation objective
PL	Opportunity review	Opportunity attributes
PL	Evaluation and prioritization of projects	Project attributes
CD	Technical/cost/competitive model development	Concept/product technical, economic and competitive features
CD	Measure customer response	Customer's perception of the concept/product features
SD	Quantitative analysis of the impact of the number of product versions	Impact of the number of product versions
DD	Trade-off execution	Critical trade-off variables value and interrelationship
PT	Establish the Level of Approximation of the Prototype	Level of resemblance between ideal final product and prototype.
DFM	Evaluation of the impact of DFM decisions on other factors	Impact in terms of development time, cost, product quality and other external features

Control context of action is another recurrence in all product development, since it is always relevant for the implementation of the best set of decisions to evaluate the trustiness of every model prediction. The activity of evaluating an alternative always requires the previous evaluation of the data that characterize each alternative, without considering to much if the alternatives are opportunities, packed projects or concept sketches.

Control facilitates the optimization of an alternative by providing an opportunity for iterative improvement. Through control, any discrepancies or shortcomings of an alternative can be detected and rectified. It fosters a culture of continuous learning and improvement, allowing for the refinement of the alternative and thereby leading to its optimization.

Furthermore, control provides a comprehensive understanding of the potential risks and bottlenecks that an alternative might encounter, allowing for the proactive development of mitigation strategies. This not only ensures that the optimized alternative is robust but also that it is resilient to potential setbacks.

3.1.4 Development:

This paragraph considers the recurrency of Development Context of Action in the entire product development model proposed.

Lvl 1 Phase	Lvl 3 Phase	Model goal
PL	Opportunity generation	Generation of product ideas aligned with the organization's strategies and goals
CD	Search internally	Generation of custom-made and modified solutions
SD	Create schematic of the product	Create a network connecting different chunks
DD	Material, shape, tolerance (any detailed feature) definition	Definition of reliable product detailed features
DD	Definition of the effect of each manufacturing variable on detailed features	Approximate the relationship between manufacturing choices and detailed design features
DFM	Manufacturing model creation	Approximate the actual manufacturing process in all its phases.

Development is deeply connected to the analyst's capability of modelling and therefore forecast the outcome of a specific set of decisions, input in general, that take place in different product development phases. This CoA involves the elaboration of the data collected in the identification CoA and structured in the structuring CoA. Furthermore, since the ability of a model to create correct prediction comes after tuning up the internal parameters of the model, this CoA is also extremely interconnected with the control CoA.

Although this CoA is therefore characterised by an almost ubiquitous presence within the product development model proposed, it is possible to point to three main areas in which this context is capable of creating supportive models:

- Project management support models: Models that are used to help defining actual tasks and actions in order to come to an effective solution in terms of organization of resources and time at disposal.
- Product design support models: These are models that are developed in order to aid in the selection and validation of different primitive ideas, concepts, entire architecture or specific subsystems.
- Manufacturing design support models: These instead are models focused on the elaboration of production information, therefore they are intended as a supportive tool in the selection and evaluation of different production plan related to different product design alternatives.

3.2 A.I. in Context of Actions:

3.2.1 Multifaceted Landscape of Artificial Intelligence: Branches, Models, Algorithms.

AI is a broad and diverse discipline which strives to copy human Intelligence inside a computer system. AI isn't one single entity but a system of branches which focus on replicating certain aspects of human intelligence. The branches may be linked to various functions of the human brain.

- **Machine Learning (ML):** a subset of AI, ML allows computers to learn from information. The capacity of the human brain to learn from experiences is matched by this branch. The brain utilizes associations, correlations, and patterns to obtain knowledge from stimuli; likewise, ML algorithms discern patterns within datasets to produce predictive models.
- **Natural language process (NLP):** The use of NLP allows machines to comprehend as well as produce human Language by utilizing the Language Processing centers of the brain.
- **Computer Vision:** Computer Vision allows computers to analyze visual details, comparable to the visual cortex of human beings.
- **Evolutionary Computation:** This branch seeks to imitate biological evolution processes as selection, mutation, crossover (recombinational) and survival of the fittest. It's strongly associated with the brain function associated with problem solving and learning.
- **Hyperparameter Optimization Techniques:** These methods are much more centered with the mind function of analyzing & calibrating its actions based upon experience.
- **Robotic Process Automation (RPA):** This branch is comparable to the brain's capability to change regular actions into habits.
- **Expert systems:** These Systems imitate human experience in a certain field, imitating the human mind's capability for reasoning and problem solving.

For an extensive replica of human intelligence, AI systems oftentimes have to integrate several branches. A model usually offers coordination by establishing the structure of the AI program. The model specifies which branches are essential for a task and their interactions. It ensures the system's parts function synchronously, similar to the brain's different regions coordinate for a certain function.

For example:

Sentiment Analysis vs. Text Classification: Both these models utilize NLP as a primary branch, but they diverge in their configurations as well as functional objectives.

Sentiment Analysis models focus on emotional content in written words, using Natural Language Processing (NLP) to analyze context and tone. Text Classification models divide input text into defined classes, using NLP to examine semantics and categorize it. Image Recognition and Scene Reconstruction models use Computer Vision and Machine Learning for different objectives. Image Recognition uses Computer Vision to identify and classify objects in images, while Scene Reconstruction reconstructs scenes using 3D technologies. Both models prioritize spatial comprehension over easy object identification.

The term "algorithms" in Artificial Intelligence goes beyond the fundamental knowledge of computational steps. In this particular context, algorithms indicate the bedrock of intelligence, enabling various AI branches to function, coordinate, and develop effectively. They regulate the modification of internal parameters and determine the communication interfaces, supporting the overall system performance. The idea of a different algorithm for configuring precisely the same AI model is particularly apparent when the model applied to the Sentiment Analysis is configured using different algorithms.

Valence Aware Dictionary and Sentiment Reasoner (VADER) versus Stanford Sentiment Analysis (SSA) Tool:

VADER is a coordinating algorithm in the sentiment analysis model, using lexical methods to assess sentiment scores in text. It changes the NLP branch to focus on individual word sentiment scores and their grammatical/syntactical connections. Stanford Sentiment Analysis uses Recursive Neural Networks to examine sentences and sentiments in general, requiring different parameters like weights and sentence structures. Machine Learning is used for classification and 3D object classification, prioritizing spatial comprehension over easy object identification.

This layered understanding, transitioning out of the specificities of specific AI branches to the broader orchestrating algorithms, facilitates the classification of various AI families. It empowers us to discern the proper CoA for each AI family, ensuring the optimal employment of specific.

3.2.2 Association between branches and CoA:

The concept of CoA is too broad to be used as a classifier of specific AI tools based on the use of specific models or specific algorithms. For this reason, only the main branches that allow the configuration of AI tools aimed at supporting the specific context have been taken as a reference for the association with the CoA. However, it is reiterated that other branches, perhaps considered as main in other CoAs, may be present as they can play an accessory role.

CoA	Branches	Function
Identification	Machine Learning (Supervised Learning, Unsupervised Learning, Reinforcement Learning);	Discern intricate patterns and insights from vast, complex datasets
Structuring	Expert systems (Decision support systems, teaching systems); Robotics (Intelligent control, Autonomous exploration); Planning (scheduling)	Establish a more structured and controlled setting, aiding in decision-making and enabling a continuous learning process; Automate routine tasks and foster an environment of precision and efficiency
Control	Expert systems (Decision support systems, teaching systems); Robotics (Intelligent control, Autonomous exploration)	Establish a more structured and controlled setting, aiding in decision-making and enabling a continuous learning process; Automate routine tasks and foster an environment of precision and efficiency

Development	Machine Learning (Deep Learning with Neural Networks); Hyperparameter optimization techniques (Grid search, random grid search, latin hypercube sampling); Evolutionary computation (Genetic algorithms);	Process and interpret massive volumes of data yielding novel solutions that may not be readily apparent; Iteratively enhance designs to optimize performance and efficacy
Communication	Natural language processing; Speech processing (Speech recognition, Speech synthesis, Speech identification); Computer vision (Object recognition, Image understanding)	Aid in understanding, interpreting, and generating human language, thereby enhancing the clarity, precision, and efficiency of information exchange among stakeholders; Augment communication by providing visual data analysis and interpretation, opening up more avenues for insightful dialogue

3.3 Bridging A.I. and Product development through CoA:

The formulation of the table provided in the attachments was an hard process executed in three crucial steps:

- I. The first step entailed the distinct definition of level 3 phases (chapter 1). This phase sought to create a concrete understanding of the product development process's specific stages, as this understanding is fundamental to the subsequent correlation with AI technologies.
- II. The second step involved identifying and defining the primary branches, models, and algorithms of AI (chapter 2). This definition was critical in understanding the role, capabilities, and unique characteristics of each AI element.
- III. The third and final step was the crux of the whole process – leveraging the established relationships between level 3 phases and the CoA, and between AI branches and the CoA. These connections served as a compass, guiding the accurate mapping of level 3 phases to appropriate AI branches, models, and algorithms.

Given the complexity of AI and the limited literature on its application specifically in support of product development, further analysis is needed to determine the association between each level 3 phase and branches in the specific model and algorithm. This research was conducted in collaboration with a data science master student, who provided insight into the relationship between branches, models, and algorithms, and their relationship with CoA. Currently, almost all activities involved in the product development process are impacted by AI, either in an augmented way, such as the use of AR for communication between team members or between lead users and producers; in a supportive way, such as expert systems and ML suggesting interpretations of large datasets; or in a substitutive way, such as computer vision and LLMs/NLP automating the cleaning of large datasets from data errors/noises and

evolutionary computation automating the generation of design alternatives given specific parameters as a reference.

3.4 Examples of Commercial Software

As a conclusion of this chapter of A.I. tools, we discuss several examples of commercial software that leverage artificial intelligence to support the design and innovation processes in product development. These tools showcase the practical applications of AI technologies, providing valuable insights into how AI can enhance efficiency, creativity, and competitiveness in the industry.

3.4.1 MarketSim

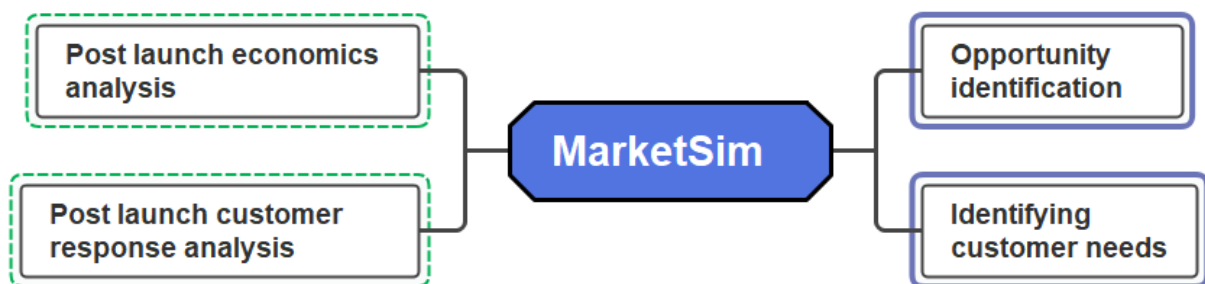

MarketSim is a sophisticated marketing simulation program that uses artificial intelligence to allow development teams to forecast the potential market success of their latest products accurately. MarketSim leverages machine learning methods such as clustering, regression analysis and time series forecasting to examine historical sales data, consumer preferences and competitive landscapes. Product developers are able to improve their market success by making data-driven decisions regarding product features, pricing strategies and market positioning. In this particular section, we examine the way MarketSim works, its different components as well as the additional value it offers to product development.

- **Data Collection and Pre-processing:** MarketSim needs a great amount of data regarding product sales, consumer behavior and market trends to make precise market predictions. It gathers information from a variety of sources such as point - of - sale systems, customer surveys, online reviews and social media. When the data is collected, it goes through pre - processing steps to handle missing values, eliminate outliers, and normalize the information, ensuring it is ideal for the subsequent machine learning algorithms.
- **Feature Engineering and Selection:** MarketSim makes use of feature engineering to develop new features that better reflect the underlying market patterns after pre-processing the information. This entails methods including data aggregation, transformation, and dimensionality reduction. MarketSim takes advantage of feature selection algorithms, like recursive feature elimination and feature importance ranking, to figure out the most crucial features for market success prediction. while minimizing the computational complexity of machine learning models.
- **Clustering and Segmentation:** MarketSim uses clustering algorithms to segment market data into distinct groups, representing consumer segments, product categories, or geographical regions. This enables targeted predictions and recommendations,

allowing development teams to adapt products and marketing strategies to specific consumer segments.

- **Regression Analysis and Time Series Forecasting:** The system utilizes regression analysis and time series forecasting to forecast market demand and price sensitivity. It estimates relationships between independent variables like product features and marketing initiatives, while analyzing sales data using time series forecasting models like ARIMA and LSTM. This enables product developers to make informed decisions on marketing efforts, pricing strategies, and features, ultimately maximizing product success.
- **Validation and Performance Evaluation:** MarketSim uses validation and performance evaluation methods to ensure predictions' validity and reliability. Cross-validation estimates performance on unseen data, while metrics like mean squared error, R-squared, and precision-recall measure accuracy. Continuous fine-tuning ensures predictions remain relevant and relevant in changing market conditions.

MarketSim is a powerful tool for scenario analysis and decision support, enabling development teams to compare and contrast product configurations, pricing strategies, and marketing efforts. It incorporates optimization algorithms to identify the best combination of features, prices, and marketing efforts for specific goals. MarketSim's advanced visualization and reporting methods make predictions and recommendations more accessible and actionable for development teams. Users can easily analyze data, identify trends, and gain insights into the market potential of their products or services. Customizable reports summarize key findings and recommendations, providing a concise overview of the market landscape and the potential impact of their choices.

The output of the software may eventually be used in conjunction with other development tools, like CAD software, product lifecycle management (PLM) systems, and project management tools, to simplify product development and enhance staff collaboration, leading to more productive and profitable products, by hooking market insights as well as predictions straight to the design, development, and control phases of the product development process.

3.4.2 IBM Watson Studio

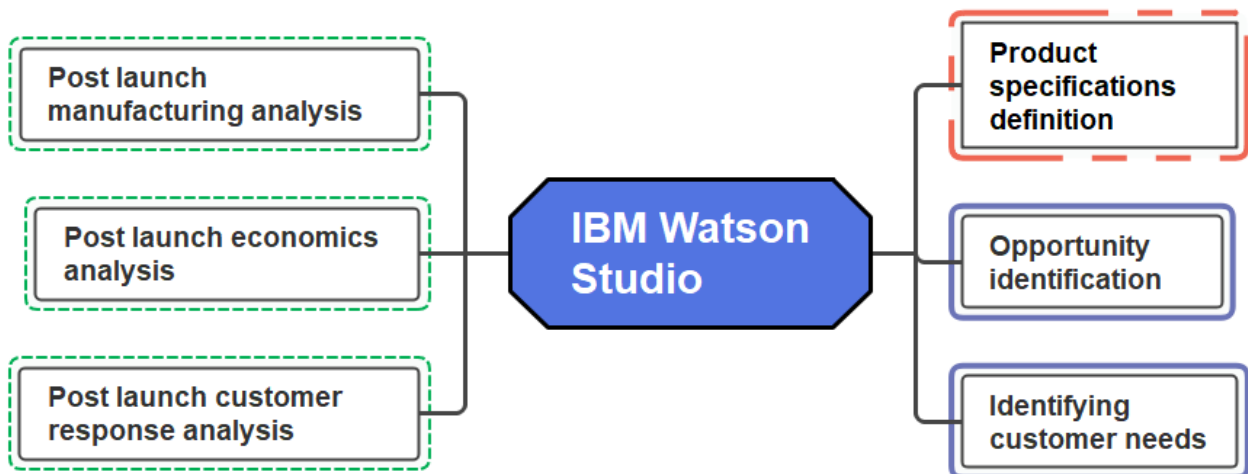

IBM Watson Studio represents a comprehensive, AI-driven data science and machine learning platform that empowers product development teams to efficiently create, train, and deploy machine learning models. This platform boasts an array of pre-built machine learning algorithms, spanning deep learning, unsupervised learning, and reinforcement learning, which product developers can harness to embed AI-driven features into their products, such as predictive maintenance, demand forecasting, and personalized user experiences.

Watson Studio's collaborative environment facilitates seamless teamwork among data scientists, engineers, and other stakeholders involved in the product development process. This environment allows users to share data, models, and code, streamlining the workflow and fostering effective communication. Watson Studio also supports integration with popular development tools and platforms, such as Jupyter Notebooks, GitHub, and Apache Spark, ensuring compatibility with existing workflows.

Watson Studio is a powerful machine learning tool for data preparation, transformation, and visualization. It supports pre-built algorithms and deep learning frameworks like TensorFlow and PyTorch. Its AutoAI feature streamlines model selection, hyperparameter tuning, and feature engineering. Watson Studio integrates seamlessly with IBM Cloud services, allowing product development teams to scale models efficiently. Real-time monitoring and explainable AI features help build trust and compliance with regulations.

IBM Watson Studio's capabilities can be applied to various aspects of the product development process, including:

- **Demand forecasting:** By leveraging machine learning algorithms, product development teams can create models to predict customer demand, allowing for more informed inventory management and production planning decisions.
- **Quality control:** Using computer vision and image recognition algorithms, teams can develop systems to automatically inspect products and identify defects, improving overall product quality and reducing manual inspection efforts.
- **Predictive maintenance:** Through the application of machine learning models, product development teams can predict the likelihood of equipment failure, enabling more efficient maintenance scheduling and reducing downtime.
- **Personalized user experiences:** By incorporating recommendation algorithms and natural language processing, teams can create products that adapt to individual user preferences and needs, fostering customer satisfaction and loyalty.

3.4.3 Hootsuite Insights



Hootsuite insights is an AI powered social media analytics application which allows development teams to obtain essential Insights into consumer sentiment, personal preferences, and behaviour. This comprehensive solution offers a significant resource for product designers and marketers, helping them to make educated choices regarding marketing strategies, design improvements and product features, ultimately leading to better market fit and consumer satisfaction.

It leverages artificial intelligence technology, including natural language processing (NLP) and machine learning algorithms, to analyse vast volumes of social media information. The platform is able to process and then interpret unstructured data, including text, pictures, and also videos, instantly, obtaining beneficial insights from conversations and interactions across social networking platforms.

NLP is a key element of Hootsuite Insights' analytics capabilities. By employing innovative NLP methods, the platform can accurately process, analyse, and comprehend the huge quantities of text information produced by social media users generated content, identifying phrases and keywords, detecting emotions and sentiment, and obtaining relevant preferences and opinions. Among the primary NLP methods employed there is sentiment analysis, which entails determining the sentiment expressed in a piece of text, such as positive, negative, or neutral. Sentiment analysis algorithms employ machine learning models trained on huge datasets of labelled text data, to recognize and classify sentiment patterns in new, unlabelled data. Hootsuite Insights can provide development teams with a snapshot of consumer sentiment toward their products, competitors, and industry trends.

The platform is able to offer accurate and pertinent information to developers by training these algorithms to recognize relationships, trends, and patterns in the data. For instance, Hootsuite Insights makes use of clustering algorithms, including K - means and hierarchical clustering, to group similar social networks content together. The identification of common themes and topics of conversation amongst consumers can offer meaningful insights to their personal preferences, desires, and pain points for development teams. Furthermore, social media audience members could be segmented based upon behaviour and interests using clustering algorithms, enabling much more accurate communication and marketing tactics.

By using the potential of AI-driven social media analytics, Hootsuite Insights provides several tools for product development teams, helping them to make much more informed choices and attain much better outcomes:

- **Product Feature and Design Decisions:** Analyzing social media consumer opinions offers valuable insights for product strengths and weaknesses, enabling design enhancements and feature improvements. This also helps identify differentiation opportunities and competitors' products.
- **Market Research and Trend Analysis:** Hootsuite Insights is an effective market analysis tool for tracking industry trends and consumer preferences, enabling teams to identify potential market opportunities and stay ahead of the curve in fast-paced industries.
- **Marketing Strategy and Campaign Optimization:** AI-driven analytics provide valuable insights into promotional campaigns' effectiveness, enabling teams to identify messages that resonate with target audiences, improving conversion rates and increasing product sales.

- **Consumer Profiling and Segmentation:** Hootsuite Insights helps create consumer profiles and segments based on online behavior, identifying customer preferences, desires, and purchasing habits for effective communication, marketing, and product design.

3.4.4 Crayon

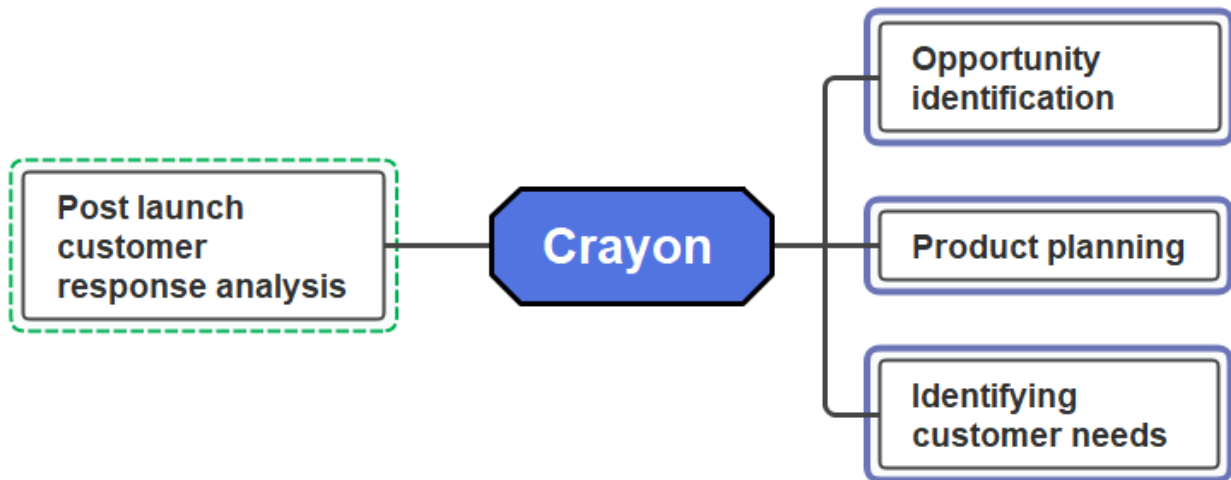

Crayon is an AI-driven competitive intelligence platform that enables product development teams to gain actionable insights into their competitive landscape. By employing a range of artificial intelligence techniques, including machine learning algorithms and natural language processing, Crayon gathers, analyses, and synthesizes data from a multitude of sources. This comprehensive approach provides product development teams with a wealth of information about their competitors, industries, and market trends, ultimately informing strategic decisions about product positioning, feature prioritization, and innovation efforts.

The Crayon platform leverages several branches of artificial intelligence from the outline to provide an effective competitive analysis. For instance, it employs machine learning (2.1) techniques to process vast amounts of data from various sources. This includes websites, news articles, social media, and product reviews. The machine learning models are trained to identify patterns, trends, and insights that can be valuable for product development teams. Furthermore, it utilizes natural language processing (2.8) to understand and interpret the textual data it gathers which involves breaking down complex sentences, identifying keywords, and understanding the context in which the information is presented. By doing so, Crayon can accurately analyse and categorize the content, providing development teams with a structured and easy-to-understand view of the competitive landscape. Its AI capabilities are further enhanced by computer vision (2.4) techniques, which allow the platform to analyse visual content such as images, videos, and graphical elements. Computer vision algorithms also enable Crayon to recognize objects, logos, and other relevant visual features within the content, providing an additional layer of information that can be useful for product development teams.

The competitive intelligence gathered by Crayon can also be used to inform the application of other AI branches implemented in the product development process: for example, the insights gained from Crayon's analysis can be used to guide the development of expert systems (2.6) that assist in decision-making processes which involves creating decision support systems

that provide recommendations based on the analysed competitive data, or designing teaching systems that help product development teams learn from the successes and failures of their competitors; similarly, the information obtained by Crayon can be leveraged to improve planning (2.9) activities within the product development process.

By understanding the competitive landscape, development teams can better anticipate market trends, adjust their strategies accordingly, and allocate resources more effectively adjusting the scheduling of product releases to coincide with market opportunities or optimizing game-playing strategies to gain a competitive advantage. Moreover, competitive insights can serve as valuable input for large language models (2.10) that can use the analysed data to generate creative ideas, draft product descriptions, and even automate documentation tasks, ensuring that their output is relevant, up-to-date, and informed by the latest market trends and competitor activities.

The integration of Crayon's AI-driven competitive intelligence into the development process offers numerous benefits, like making more informed decisions about product features, design improvements, and marketing strategies, leading to better market fit and consumer satisfaction; providing a comprehensive and structured view of the competitive landscape, allowing teams to identify opportunities and threats that may have otherwise gone unnoticed and eventually promoting a data-driven approach to product development, fostering a culture of innovation and continuous improvement.

3.4.5 Brandwatch



Brandwatch is a social listening and analytics platform that plays a crucial role in supporting product development teams as they monitor and analyse online conversations surrounding their products, brands, and competitors. The platform employs a combination of natural language processing (NLP) techniques, sentiment analysis algorithms, and machine learning models, which work together to offer valuable insights into consumer preferences and emerging market opportunities.

The application of NLP techniques allows for the efficient processing and understanding of vast amounts of unstructured text data derived from various online sources such as social media, forums, and blogs. NLP techniques are employed to perform tasks such as tokenization, part-of-speech tagging, and named entity recognition, which enable the platform to identify and categorize relevant information based on user-defined criteria. This is essential for understanding the context of online conversations and accurately capturing consumer sentiment.

Sentiment analysis is another key component that enables product developers to gauge

consumer feelings: they are often based on supervised learning techniques, and they are trained on labelled datasets to classify textual data as positive, negative, or neutral. These algorithms can identify and interpret various forms of sentiment expression, such as emojis, slang, and colloquial language, providing a more accurate and comprehensive representation. Machine learning models facilitates the job: for example, by applying clustering algorithms, like k-means and hierarchical clustering, the platform can group similar data points together, enabling for the identification of emerging trends and themes in online conversations. Additionally, anomaly detection algorithms can help identify unusual patterns or sudden changes in consumer sentiment, which may signal potential issues or opportunities that warrant further investigation.

AI-driven analytics can significantly inform product development decision-making by highlighting consumer preferences, revealing unmet needs, and inspiring innovation. Brandwatch can also inform marketing and communication strategies, enabling targeted campaigns and strategic partnerships. It can monitor the impact of efforts, make data-driven adjustments, and provide competitive intelligence by monitoring competitors' strategies and tactics. As AI technologies advance, platforms like Brandwatch will incorporate advanced techniques like deep learning algorithms for NLP tasks and reinforcement learning to improve efficiency and accuracy in data processing and analysis.

3.4.6 Tara AI

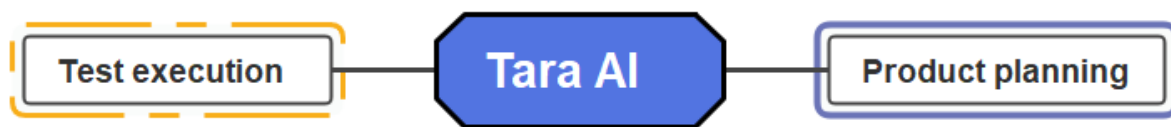

Tara AI is a platform designed to assist with project management and product development processes. It uses artificial intelligence to predict the time and resources required for a project, making it easier for teams to plan and execute their work.

It does this by analyzing past projects and the work patterns of the team. It takes into account factors like the complexity of tasks, the skills of team members, and the time taken for similar tasks in the past. This allows Tara AI to provide a more accurate estimate of the time and resources required for a project.

The uniqueness of team routines is not just understood but also leveraged by Tara AI. It uses this information to optimize project planning and execution. For instance, if a team works faster on certain types of tasks, Tara AI will take this into account when assigning tasks and predicting project timelines.

Based on this analysis of past performances, it can also suggest which team member is best suited for a particular task. This not only helps in assigning the right person to the right task but also in balancing the workload among team members.

Tara AI is also capable of predicting potential issues that might arise during the course of a project. It does this by analyzing historical project data and identifying patterns that have previously led to problems.

For example, if the AI notices that a particular type of task often takes longer than estimated, it might flag this as a potential risk for future projects. Similarly, if it identifies that certain

combinations of tasks or team members often lead to bottlenecks, it can highlight these as potential issues.

Once potential issues are identified, Tara AI can suggest solutions. These might include adjusting the project timeline, reassigning tasks, or providing additional resources. The goal is to proactively address potential problems before they impact the project, thereby improving project outcomes and efficiency.

It uses machine learning algorithms to analyze past data and predict future outcomes. This includes predicting the time required for tasks, identifying potential bottlenecks in the project, and suggesting optimal task assignments. The AI is also capable of learning and improving over time, making the predictions more accurate as more data is collected

3.4.7 Tableau



Tableau is a ground-breaking data visualization and analytics platform that has changed the way development teams process, evaluate, and draw insights from intricate datasets. It combines the power of different types of artificial intelligence (AI) to deal with the challenges of big data in product development, which includes figuring out market opportunities, optimizing product designs and streamlining the decision-making process. This section considers Tableau's capabilities and their impact on product development at different phases.

Tableau utilizes key AI technologies like machine learning, pattern recognition, clustering algorithms, and anomaly detection to enhance data visualization and analytics capabilities. These algorithms automate data analysis tasks, allowing teams to focus on strategic and creative aspects. For example, in product development, Tableau's machine learning capabilities enable developers to develop predictive models to accurately predict demand, making better choices in product attributes, pricing, and market positioning.

Another technique utilized in Tableau is clustering algorithms, which group related data points based on their features. uncovering trends, relationships and insights hidden in product development data taking into consideration also customer feedback, product usage patterns and market research information. Clustering algorithms is also utilized to segment customers based on their personal preferences to recognize target customer segments and develop solutions that meet their customers' needs and expectations. By understanding these customer preferences, development teams can deliver products that resonate better with their target audience, to reach higher customer satisfaction and improve market success.

Pattern recognition is another AI method used in Tableau and it consists of determining recurring patterns, relationships, or structures within data. Pattern recognition algorithms enable development teams to uncover hidden trends, dependencies and correlations within their data to prioritize the most crucial features for their products by determining associations between product features and customer satisfaction. Additionally, it can be utilized to investigate the correlation between product usage patterns and customer retention, enabling teams to recognize areas for improvement and modify their products accordingly.

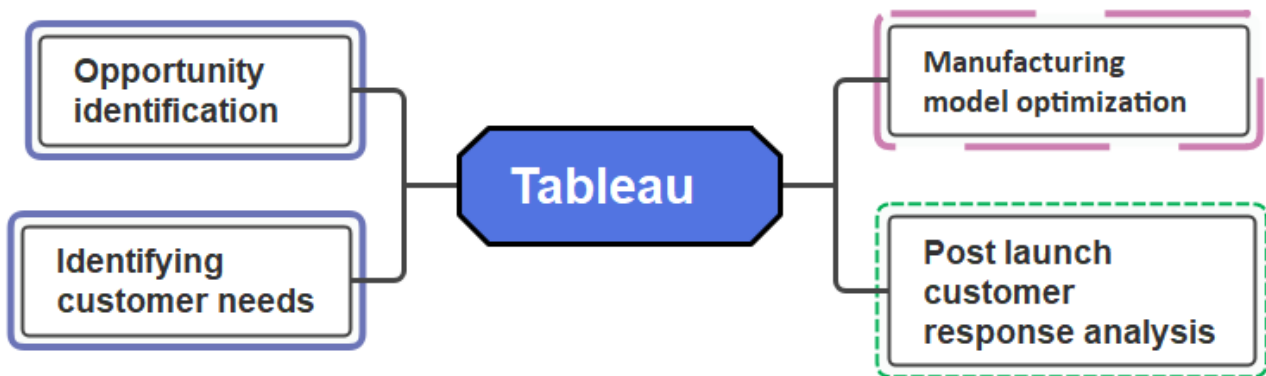
Tableau utilizes anomaly detection to identify data points deviating from expected patterns, enabling teams to identify unexpected sales spikes, product performance issues, or customer complaints. This feature helps identify manufacturing process issues and customer feedback trends, allowing for early correction and quality control checks. Tableau's robust platform combines machine learning, clustering algorithms, pattern recognition, and anomaly detection, enabling product design and development optimization. Its user-friendly interface and extensive visualization capabilities foster a data-driven approach, enhancing efficiency and promoting innovation and creativity within the team.

3.4.8 Synera

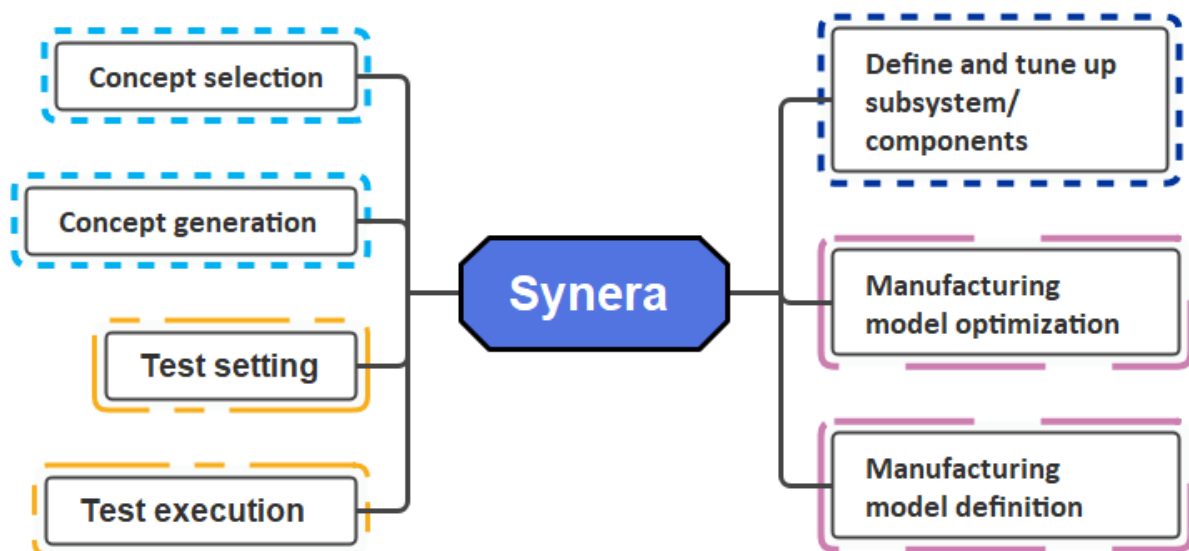

Synera, a state-of-the-art decision support tool, was created to help product development teams in optimizing their design options by analysing several criteria concurrently. Its AI-driven approach enables product designers to look into a wide range of design alternatives efficiently and rapidly, leading to well-informed decisions and better product quality. This section explores the internal workings of Synera, the tools it uses, as well as the advantages it brings to product development.

Among the primary components of Synera is its use of multi-objective optimization methods to find the best trade-offs between conflicting design goals, like cost, weight, and performance. Multi-objective optimization is a mathematical process which strives to identify the optimal solution to a problem with many contradictory goals. This optimal solution is obtained through a technique called Topology Optimization, which determines, through a series of iterations, the best solution to the structural problem faced. Mathematically a structural problem can be modelled considering the following elements.

- Volume constraints: they allow the definition of the points in the three-dimensional geometric space that should not be involved in the optimisation process.
- Boundary conditions: they specify the value or the derivate of optimisation variables, like displacement or stress.
- Manufacturing constraints they reflect the limitations and the possible outcomes associated with a particular manufacturing process.
- Equilibrium equations: A system is said to be in equilibrium when the sum of the forces and the sum of the moments acting on it are both zero, meaning the system is neither translating nor rotating.
- Objective functions: the objective refers to the function that is being maximized or minimized.

Problems of this type are therefore governed by a system of partial differential equations, characterised by numerous local solutions. This type of systems can be solved in many ways and one of them is the class of gradient-based optimization algorithms, where the sensitivity of the objective function to changes in the design variables is calculated and used to update the design. The process is typically iterative and continues until some stopping criterion is met.

The class of evolutionary algorithms, known as genetic algorithms (GAs), is another solution based upon the natural selection procedure. In Pareto-based genetic algorithms, a population of possible solutions is evolved over several generations to enhance their fitness concerning several objectives. The algorithm begins with an initial population of randomly generated solutions, and each solution is analysed based upon its fitness for each objective.

GAs use genetic operators as selection, crossover (recombination) and mutation to produce new offspring solutions throughout the evolutionary process. The selection operator favours solutions having much better fitness values, while crossover and mutation operators bring genetic diversity into the population by merging and altering the solutions, respectively.

For Pareto based GAs, the concept of Pareto dominance is employed to compare and rank solutions in the population. A solution is said to dominate another if it's better or equivalent in most objectives and purely better in more than one objective. The Pareto front is a set of non-dominated options that provide the most effective compromises between opposing goals.

The AI driven strategy of Synera is meant to help in different phases of product development, which includes concept development, detailed design, testing and refinement. Synera allows development teams to make better choices based on a holistic awareness of the trade-offs between several design goals by using the strength of multi-objective optimization methods.

The two main objectives are the minimisation of mass and average body tension (or maximization of stiffness) and are governed by three main parameters:

- Strut density: when set to high values, the final model is characterised by a robust structure.

- Global safety factor: It defines the average voltage level considered acceptable for the whole body (it is not a constraint on a maximum tension value relative to a particular surface).
- Shape quality: low values of this parameter lead to models with very discontinuous.

An additional parameter is then considered that defines the degree of complexity of the model as the number of nodes/fine elements that will compose it. This last one takes in consideration the hardware limits of the computer used to activate the optimisation process.

In summary, the entire basic process of producing a single topology optimized model can thus be reduced to the basic steps expressed by the following diagram:

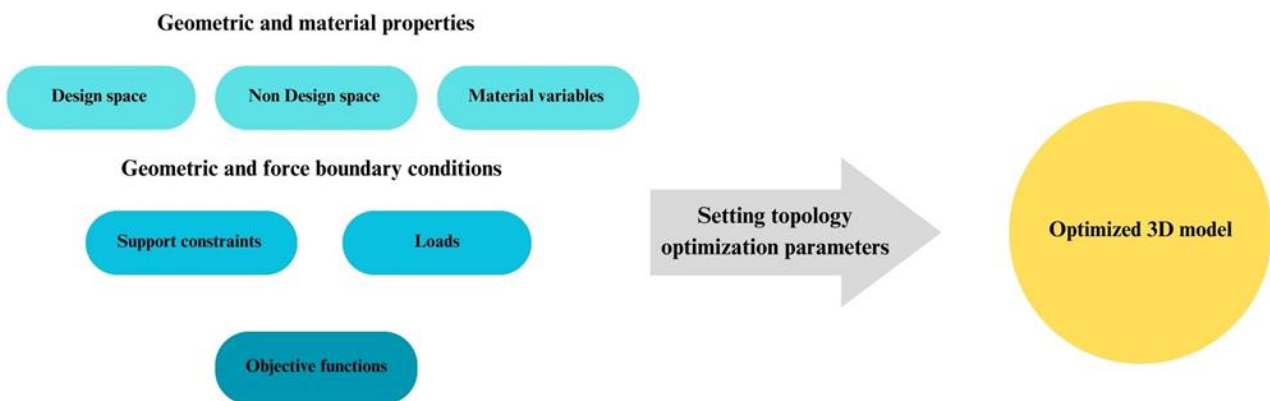

Product designers generate and then evaluate several design concepts during the concept development stage based upon feasibility, desirability, and viability. Synera aids in this process by offering a quantitative framework for comparing various design alternatives based on their overall performance concerning several objectives. Product designers are able to identify promising design concepts which achieve a sense of balance between objectives, like minimizing cost while maximizing performance and dependability.

Taking in consideration the minimization of the cost, the choice of the manufacturing process takes an important role in defining the planned cost of the product. Features implemented by Synera give the user the possibility of implement a dynamic cost model, based on the following inputs:

- 3D geometrical model: this model can be created using topology optimizations feature.
- Manufacturing process variables: they can be different for each of the three manufacturing process available (milling, casting, LBM).
- Material and personnel cost: in case of topology optimized models, only the last type of costs must be considered.

The next step consists in enabling the manufacturing process optimization, and therefore tuning up the manufacturing relevant variables. General manufacturing optimization processes require the definition of a set process variables and at least one response parameter. Then it is possible to generate combinations of manufacturing variables upon which the response parameters are calculated. There are three main algorithms used to generate all the combinations: latin hypercube, grid search, random grid search.

The choice of the generative algorithm affects the minimal number of combinations required to

identify the optimal one and therefore the time necessary to fine tuning the manufacturing process.

Product development teams concentrate on defining the general architecture, taking in consideration the interaction (at least from a structural point of view) between multiple previously generated component models in order to create an optimal system. The process entails separating the product into its subsystems and evaluate how design choices can impact the general performance of the system itself. Synera enables system-level design by allowing designers to explore a broad range of architectural alternatives and evaluate their trade-offs in terms of pre, performance, weight along with other related factors. which can help designers determine optimal system architectures that meet the desired product goals.

Product designers refine the design concepts selected during the detailed design stage and create detailed specifications for every component and subsystem. Synera facilitates this by offering a cost-effective technique for exploring the design space and identifying optimal solutions that meet multiple goals.

Development teams verify and also validate their designs throughout the testing and refinement stage through simulations, prototypes and pilot production runs. The software is able to help in this stage by making it possible for engineers to do virtual testing and optimization of the designs, therefore determining possible issues and areas for improvement.

It can be utilized for simulation-based optimization studies, where the performance of a design is compared under various operating conditions and loading scenarios. Engineers can utilize the analysis of these simulations to obtain useful insights into the robustness and reliability of their designs, determine possible failure modes and make design modifications to deal with these concerns. The software can utilize machine learning algorithms to evaluate huge amounts of historical product data, identifying patterns and trends, and developing predictive models to guide design selections.

The results and accuracy of virtual testing is determinate also by the choice of the predictive/training model used to bring out the relationship between the design and the forecasting variables. These models include the use of Linear regression, Random Forest, OLS Simple Linear regression and Neural Networks.

All considered, product development departments could reap the benefits of integrating Synera's optimization abilities into the product development process for a variety of reasons, including:

- **Improved Decision-Making:** The quantitative approach to multi-objective optimization developed by Synera helps designers to obtain a comprehensive and clear understanding of the trade-offs among design objectives, allowing them to make educated choices which result in better products.
- **Accelerated Product Development:** The ability to quickly investigate and assess a great variety of design alternatives making use of optimization algorithms can considerably reduce the time spent on design iterations and actual physical tests, ultimately accelerating the product development process.
- **Discovering new design:** optimization methods can help product designers spot novel and revolutionary design solutions that may not be apparent through standard design methods. This can result in the creation of novel products that offer distinct value propositions and competitive advantages on the market.

- **Cost Reduction:** Synera allows product development teams to determine optimum design solutions that meet several goals, leading to lower material costs, manufacturing processes, and physical testing - ultimately leading to more affordable products.

The main disadvantage of synera, especially considering the financial limits of small studios, is that it requires the the access to other third-party software, but on the other hand this characteristic allows other already structured firms to implement the utilization of this software in the product realisation routines stucked to the team itself.

3.4.9 Fusion360

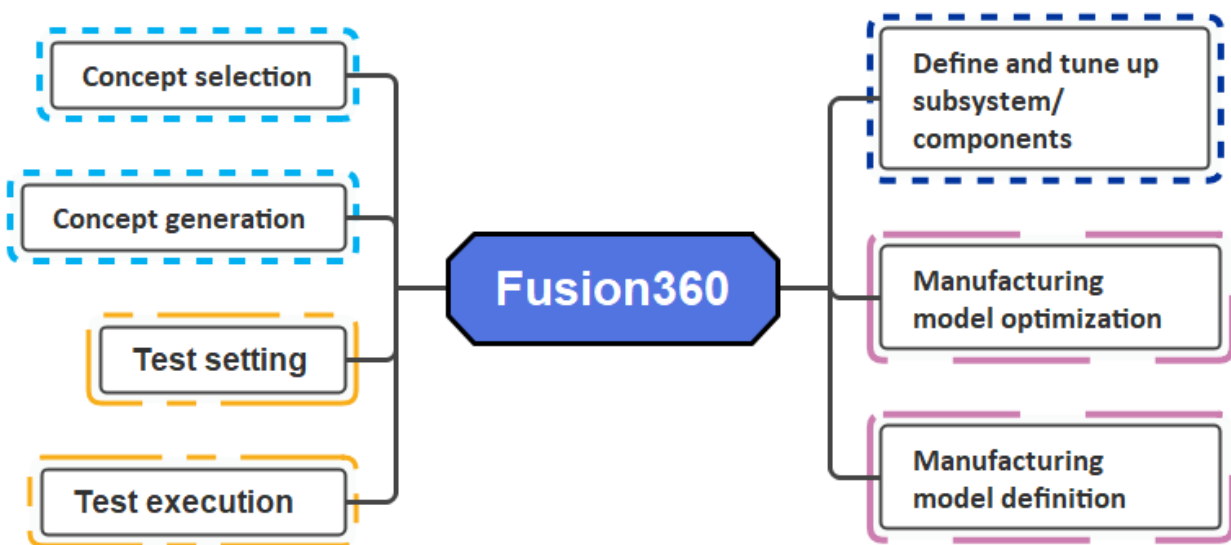

Fusion360 is a comprehensive cloud-based 3D computer-aided design (CAD), computer-aided manufacturing (CAM), and computer-aided engineering (CAE) platform developed by Autodesk. It offers a wide range of features and tools to support the product development process, including parametric and direct modeling, assembly design, rendering, and simulation. One of the most notable features of Fusion360 is its AI-driven generative design module, which has the potential to drastically reduce the effort associated to the concept exploration.

Generative design is an innovative approach to product design that employs artificial intelligence algorithms to explore and generate numerous design possibilities based on user-defined objectives and constraints. Connecting to what has been expressed to the case of synera, Generative design and topology optimization are the two main solution families operating in this direction. There is no well-defined dividing line separating them, so much so that they are often used as synonyms, and it seems that Generative design exploits topology optimization itself.

One of the possible distinctions between the two is proposed below.

Topology optimization relays on a process of progressive removal of portions of material from a rough model, with the aim of reaching or coming as close as possible to a predefined set of targets/objectives, given a set of constraints.

During the execution of generative design, on the other hand, material is created from a discrete set of fundamental, well-defined components, such as housing holes for shafts or bolts, again depending on a sequence of constraints and the chosen objective functions.

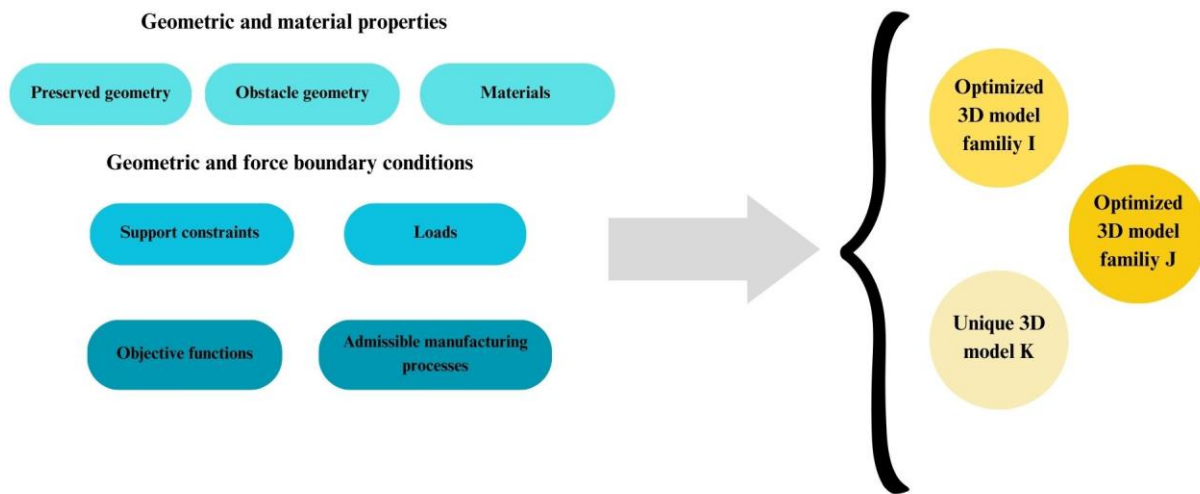

It should also be noted that fusion 360 only allows customisation of the target functions by importing a script in Python or C++ via the available API, therefore turns out to be a more complex and less immediate task in comparison to Synera.

A single run of generative design produces, unlike topology optimization, a multitude of designs already clustered by comparing the individual models generated, thus it can be more useful and immediate in contexts where there is not yet a strong structuring of the product idea.

All of this is possible only by virtue of using cloud computing, whereby the limitations in terms of graphics memory and RAM available to the workstation can be bypassed while requiring on the one hand the consumption of tokens on the other hand often quite long execution times are required.

Conceptually, the generative design process in Fusion360 typically involves the following steps:

1. **Problem Definition:** in this initial stage, the designer defines the design problem by specifying the functional requirements, design constraints, and performance objectives for the product. This may include defining the boundaries of the design space, setting material and manufacturing constraints, and establishing performance targets, such as minimizing weight or maximizing strength.
2. **Design Space Exploration:** once the problem is defined, Fusion360's AI-driven algorithms begin to explore the design space by generating a vast number of design alternatives. These algorithms employ advanced optimization techniques, such as topology optimization, lattice optimization, and multi-objective optimization, to create diverse and innovative design solutions that satisfy the specified objectives and constraints.
3. **Design Evaluation:** as design alternatives are generated, Fusion360's built-in simulation tools are used to evaluate their performance under various conditions, such as structural loads, thermal stresses, and fluid dynamics. This allows the designer to

quickly identify the most promising design solutions based on their performance metrics, such as weight, strength, and deflection. The comparison between the output models is also simplified by the automatic creation of charts and diagrams and the possibility to export each single design and use the model for deep simulations.

4. **Design Selection and Refinement:** after the performance evaluation, the designer can select one or more design alternatives for further refinement and optimization. Fusion360's parametric and direct modeling tools enable the designer to easily modify and fine-tune the generated designs, ensuring they meet the desired performance goals and adhere to manufacturing requirements.
5. **Design Validation and Manufacturing:** Finally, once the design is refined and optimized, Fusion360's simulation tools can be used to validate its performance under real-world conditions, such as fatigue, vibration, and thermal stress. If the design meets the specified performance targets, it can be exported to various manufacturing processes, such as 3D printing, CNC machining, or injection molding, directly from the Fusion360 platform.

The design capabilities of Fusion360 offer several key benefits to development teams:

- **Vast exploration of different design solutions:** By automating the generation of design alternatives, Fusion360 allows designers to explore a much broader range of design possibilities than traditional design methods, leading to more innovative and unconventional design solutions that might not have been considered otherwise.
- **Improved Efficiency and Decision-Making:** algorithms can quickly generate and evaluate thousands of design alternatives, enabling product development teams to make more informed decisions and select the best design solutions based on their performance metrics. Fusion 360, moreover, arrange in-software visual and more parametric diagrams which can be useful in the data communication between teams from different areas involved in the product development. This can significantly reduce the time and effort required to identify optimal design solutions, ultimately accelerating the product development process.
- **Sustainability and Material Optimization:** AI can help create more sustainable products by optimizing material usage and minimizing waste, e.g. identifying design solutions that use less material while maintaining structural performance, leading to more eco -friendly and cost-effective products.
- **Customization and Personalization:** AI-driven generative design can enable development teams to create bespoke and personalized products tailored to specific user needs and preferences. By incorporating user input into the design process, customized solutions that cater to individual requirements, offering a higher level of personalization and differentiation in the market, can be generated.
- **Enhanced Collaboration:** Fusion360's cloud-based platform allows product development teams to collaborate seamlessly in real-time, enabling designers, engineers, and manufacturers to work together more effectively, which can help streamline the design process, reduce communication barriers, and foster a more collaborative and innovative design environment.
- **Integration with Manufacturing Processes:** being generative design capabilities tightly integrated with its manufacturing tools, seamless transition from design to production is enabled. This helps product designers to ensure that their designs are

not only optimized for performance but also for manufacturability, ultimately reducing the time to market and ensuring a smoother product launch.

Despite the numerous benefits, Fusion360 also presents some challenges and considerations for product development teams:

- **Overcoming the Complexity Barrier:** The generative design process can sometimes generate complex and intricate design solutions that may be challenging to manufacture using traditional methods. Product development teams need to carefully consider the manufacturability of their designs and employ appropriate manufacturing techniques, such as additive manufacturing or advanced CNC machining, to bring these designs to life. Also, the interface is stiffer in comparison to the one in Synera.
- **Managing Intellectual Property and Data Security:** As algorithms generate design solutions based on user input and proprietary data, development teams must carefully manage their intellectual property and ensure that sensitive data is adequately protected which may involve implementing strict data access controls, encryption, and other security measures to safeguard valuable design information.
- **Balancing Performance and Aesthetics:** generative design often prioritizes performance optimization over aesthetics, which may result in designs that appear unconventional or unappealing. It is therefore important to strike a balance between optimizing for performance and maintaining a visually appealing design that resonates with end-users.

3.4.10 Midjourney

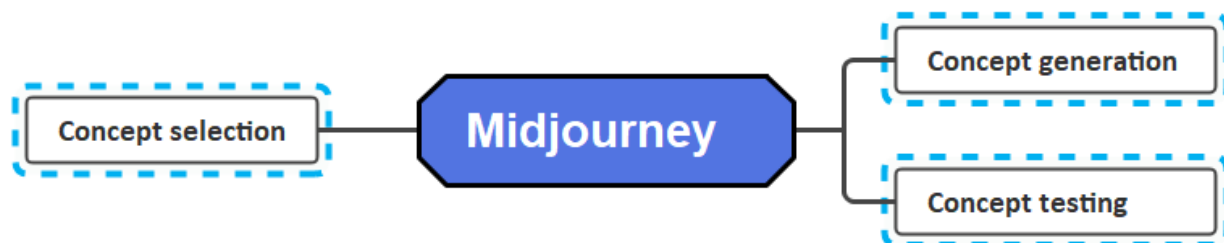

The applications of this software, but in general of all text-to-image, text-to-model and image to image software, fill the limits of more engineering-oriented tools in all those contexts in which specifications and in general fewer tangible variables play a more important role.

In the nascent stages of concept development, particularly in contexts where the product ideation lacks a clear definition, tools like midjourney methodologies can serve a multitude of functions. These scenarios provide fertile grounds for the application of such techniques, which can be instrumental in the brainstorming stages as a catalyst for image generation. Such methodologies can efficaciously guide the juxtaposition of diverse ideas, thereby fostering an environment conducive to creativity and innovation.

Midjourney methodologies and similar approaches can function as a support structure during the ideation process, facilitating the examination and assessment of the most valuable ideas. They can engender a variety of outputs that encapsulate the preferences expressed by a diverse range of respondents. This inclusivity ensures that the final product or concept is well-rounded and catered to a broad spectrum of potential users or consumers.

Incorporating these methodologies into the concept development process can lead to a more robust and comprehensive understanding of the product or idea at hand. It allows for a more informed decision-making process, better alignment with user or consumer preferences, and a higher likelihood of producing a product or concept that is both innovative and valuable.

For example in a scenario of a preference analysis conducted through a comprehensive survey in which a representative set of respondents, characterized by different categories of attributes, had to express their preference for significant combinations of semi-qualitative characteristics of a set of cars, Midjourney can on one hand be employed to assist respondents in providing more accurate and thoughtful responses by visualizing each combination of car attributes, on the other can be used to analyze the preferred combinations of car attributes for each cluster of users, thereby identifying patterns and trends in preferences across different demographic groups.

The first versions of this tool is based on GAN (Generative Adversarial Networks) type models, that can convert a text into an image and/or sequence of images (potentially low-frame-count video).

This model can be described as a dialogue between two parts, one of which is aimed at proposing and refining the image, while the other is focused on the criticism of the different images proposed in order to obtain an image that is as closely aligned as possible to the initial demands.

As the user base using Midjourney has grown, however, three fundamental problems related to the use of these algorithms have emerged:

- **Failure to converge:** the generator and discriminator fail to determinate an optimal image and therefore they remain in a continuous loop.
- **Mode collapse:** the discriminator can't discriminate between a real image and the generator's output, and for this reason the generator itself produces the same output regardless of its actual quality.
- **Vanishing gradients:** in this situation the generator can't learn by adjusting its parameters (weights and biases) through a process called backpropagation, since the discriminator passes insufficient information to it. As a company the learning process and the generation of output are blocked.

These limitations lead to development of the Diffusion model, which unlike GANs progressively create an image rather than all in one moment. On this type of model was built the foundations of the latest versions of Midjourney.

3.4.11 DALL-E

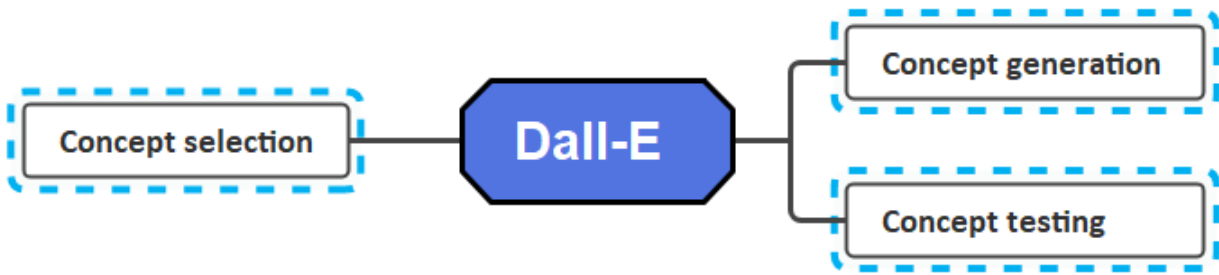

DALL-E is a specialized iteration of the GPT-3 language model that's been uniquely trained to generate images based on textual descriptions. This is achieved through a modified transformer architecture, a type of neural network generally utilized in natural language processing tasks, but in this case, adapted for the generation of images and integrated with a Diffusion model.

A key feature of DALL-E is its enhanced capacity to interpret less specific prompts, thanks to the use of trained Latent Language Models (LLMs). As such, DALL-E could be an advantageous tool in supporting the development of diverse product ideas at the cost of producing less “artistic” image than Midjourney. Additionally, DALL-E presents a novel feature for expanding and modifying input images, essentially allowing for the creation of a complete environment surrounding the initial image.

Another fundamental difference linked to the user experience of Dall-e compared to midjourney is the absence of all those features that want to modify the aesthetic style with which the images are generated.

Arguably the most groundbreaking aspect of DALL-E is the anticipated update to SHAP-E, transitioning the software from text-to-image to text-to-model, capable of generating Standard for the Exchange of Product Data (STEP) models. This progression holds considerable potential for application in more technical areas, such as engineering, since this model could be optimized and become a reliable reference for a variety of other fields such as the manufacturing process development.

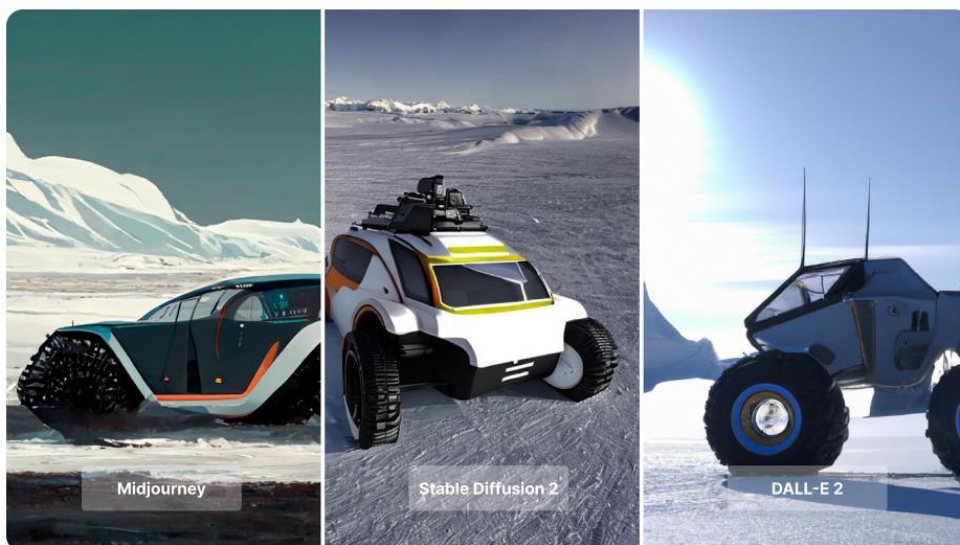
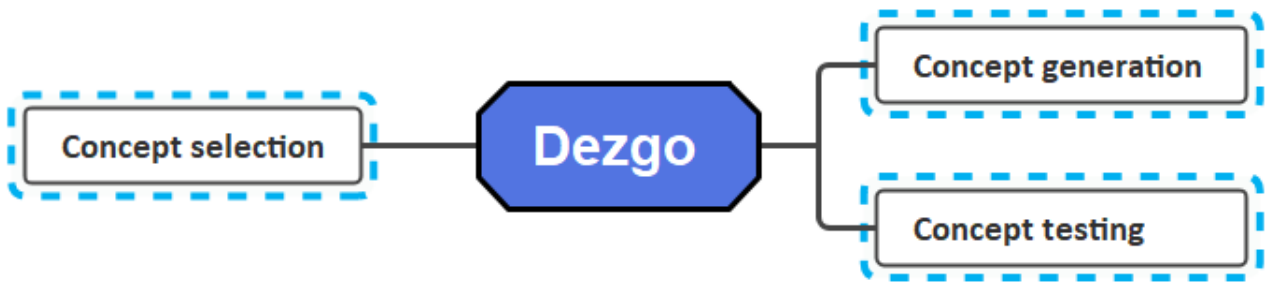

Image Prompt: futuristic rally vehicle exploring antarctic

3.4.12 Dezgo



Dezgo is an AI-based image-to-image generator that uses Stable Diffusion AI to edit an existing image to fit a given text description. The user can provide a text prompt that describes how the final image should look like and adjust the strength of how strongly the original image should be altered, then the user can upload the original image to be modified and select the AI model used to generate the image.

By combining the user's input text with the selected original image, Dezgo generates outputs that reflect the user's creative intent while infusing new elements inspired by the text prompt. In situations where there is yet no codifiable data in written form about the preferences of one or more classes of potential customers, image-to-image tools of this kind can help explore possible alternatives visually.

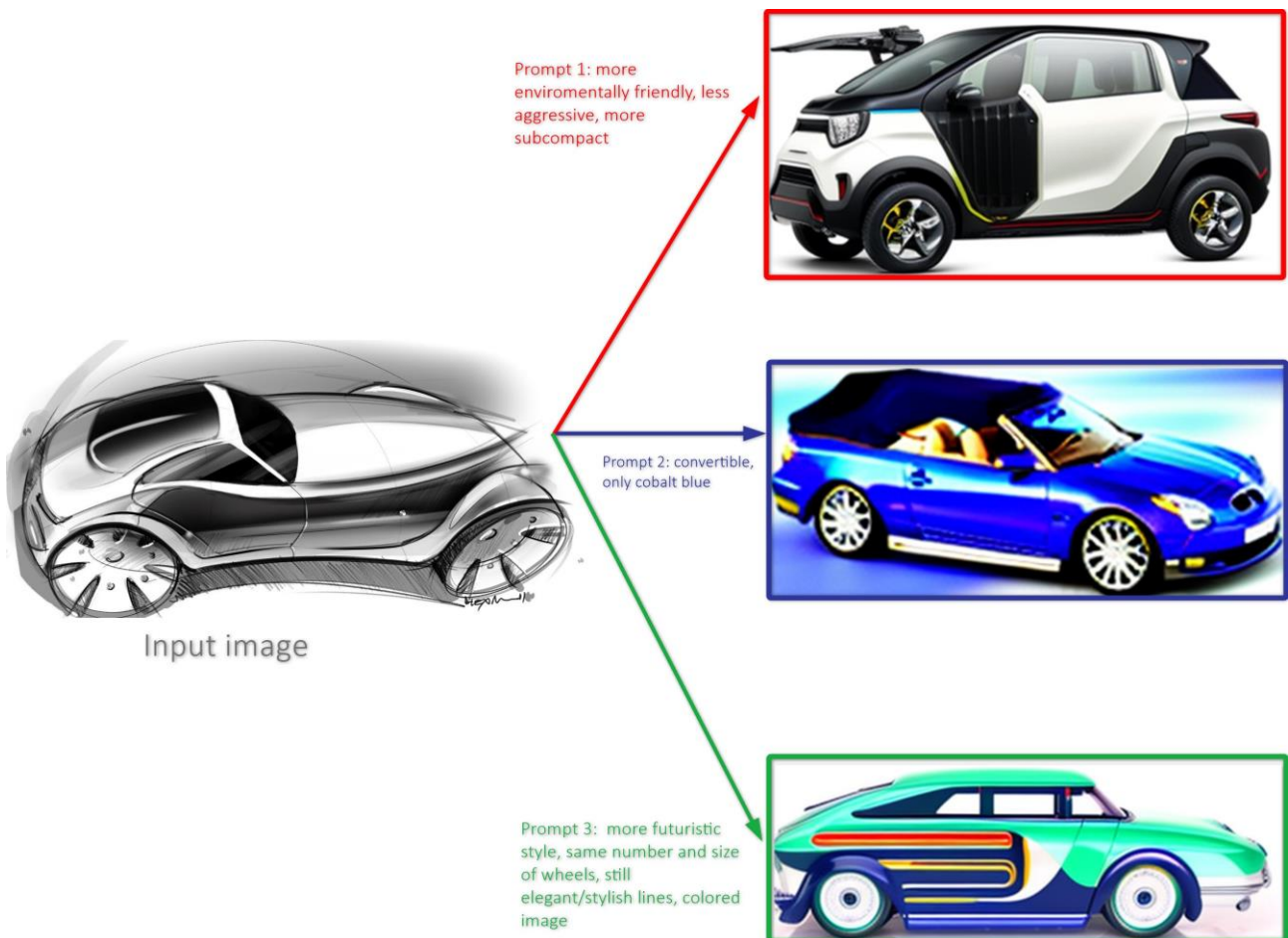
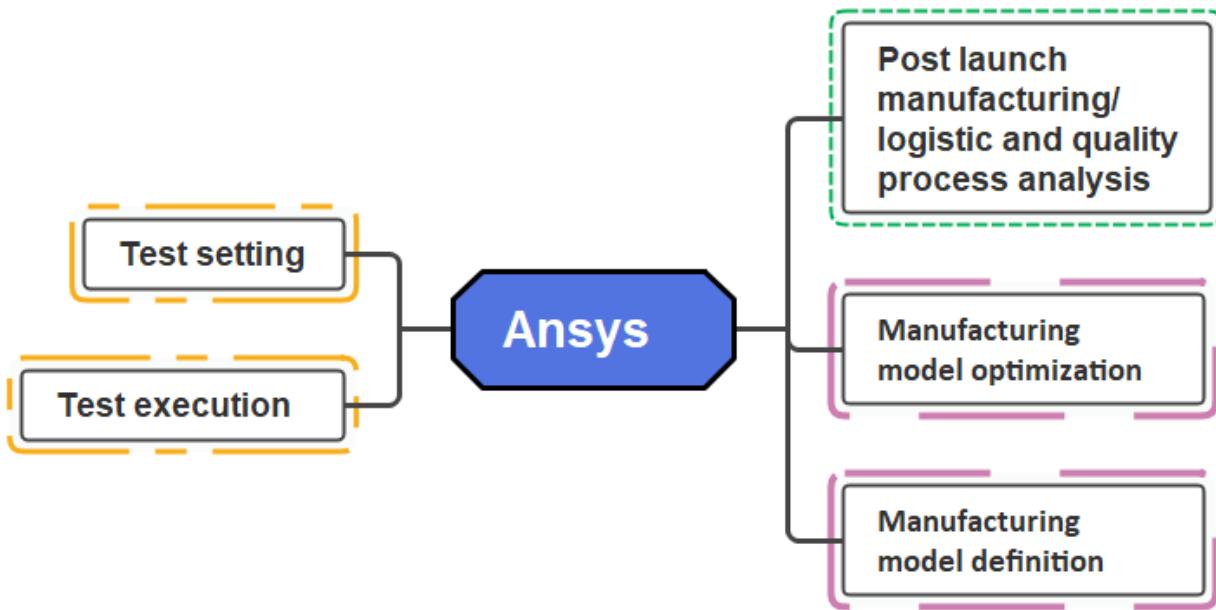

Figure 49 Example of image-to-image generation

3.4.13 ANSYS



ANSYS is a leading engineering simulation software suite which brings together the most recent artificial intelligence (AI) and machine learning (ML) technologies to optimize product designs and reduce physical testing. It allows product developers to simulate and predict the performance of different design alternatives under different conditions, including stress, temperature, and fluid dynamics. This enables teams to make informed design decisions, hasten and lower the cost of physical testing, and boost efficiency and reliability. ANSYS exploits different techniques to learn from previous simulations and user inputs, allowing the software to continuously enhance its predictive abilities and provide more precise results. This never-ending learning process is made possible by the implementation of supervised learning, unsupervised learning, and reinforcement learning algorithms.

The software is trained using supervised learning algorithms on labelled data, enabling it to make predictions or classifications based on existing patterns and relationships. In terms of product design, supervised learning can be employed to generate predictive models for material properties, structural performance, along with various other crucial design attributes. It analyses historical data on similar structures and their respective failure points, being then able to predict the failure points of a structure under specific load conditions. Unsupervised learning algorithms, on the other hand, enable ANSYS to identify hidden patterns, trends, and relationships within unlabelled data. The software can effectively evaluate huge datasets and also give valuable insights to teams with the aid of clustering and dimensionality reduction. Engineers can rapidly identify the most promising design alternatives based on their overall performance.

Error and trial can be implemented to optimize product designs with reinforcement learning algorithms within ANSYS to boost its decision making and general design by maximizing a predefined reward function via iterative learning processes. This is particularly helpful when traditional optimization techniques are unfeasible or computationally costly. In a real-life example, reinforcement learning can be used to optimize the shape of an aircraft wing to minimize drag while maintaining structural integrity.

The application of neural networks, especially along with deep learning techniques, is another important component of ANSYS. Deep learning methods, like convolutional neural networks (CNNs) and recurrent neural networks (RNNs) can efficiently process complex and high-dimensional data, allowing the software to handle much more intricate design problems. CNNs can be utilized in computer vision applications inside ANSYS to determine features, shapes, and patterns for product designs, and RNNs can be used to model time-dependent phenomena like fluid flow and heat transfer.

ANSYS implements evolutionary computation techniques such as genetic algorithms to tackle challenging optimization issues. Genetic algorithms can explore a vast search space of design options by modelling natural evolution, leading to optimal configurations which meet different goals, including manufacturability, performance, and cost. This can result in more creative and effective product designs that boost the competitiveness and market viability of the products.

3.4.14 GE Digital's Predix

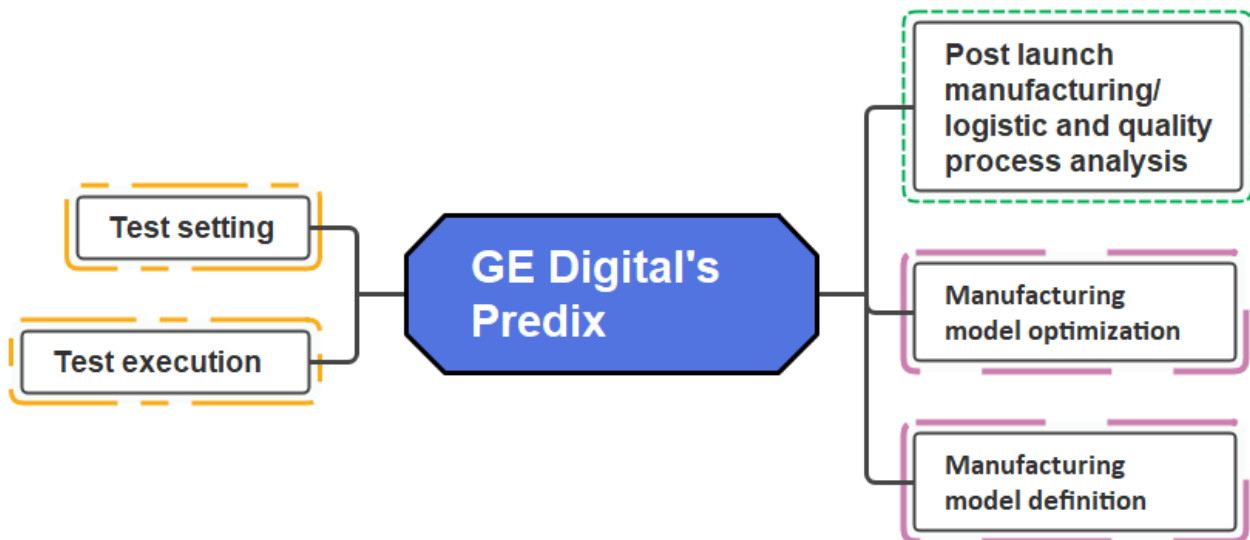

GE Digital's Predix platform is a remarkable example of how artificial intelligence (AI) can be effectively employed in the product development process, specifically in the realm of industrial equipment and processes. This industrial internet platform aims to optimize the performance, reliability, and efficiency of industrial systems focusing on predictive maintenance algorithms, anomaly detection models, and process optimization techniques: it allows product developers to actively monitor and enhance their products in real-time, which results in a significant reduction in costs, minimized downtime, and improved product quality and reliability.

To appreciate the impact of GE Digital's Predix on product development, it is necessary to delve into the specific AI techniques that are employed within the platform and how they contribute to the improvement of industrial systems:

- **Predictive maintenance:** it is a crucial aspect of optimizing the performance and reliability of industrial equipment. By employing supervised learning algorithms, Predix is capable of analysing historical equipment data, such as sensor readings and maintenance logs, to identify patterns that may indicate potential equipment

failures. These patterns are used to build predictive models that estimate the remaining useful life (RUL) of components and determine the optimal maintenance schedule. It proactively identifies and address potential issues, reducing equipment downtime and associated costs while extending the overall lifespan of their products.

- **Anomaly detection:** it is another essential aspect of improving the reliability and efficiency of industrial systems. Predix leverages unsupervised learning algorithm like clustering and autoencoders to analyse large volumes of sensor data from equipment and processes, identifying deviations from normal behaviour patterns. These deviations, or anomalies, may be indicative of underlying issues, such as equipment malfunctions, process inefficiencies, or quality control problems. Detecting and addressing these anomalies in real-time is imperative to proactively mitigate potential issues before they escalate. Moreover, the insights gained from anomaly detection can inform future product design iterations, enabling teams to develop more robust and reliable products.
- **Optimizing industrial processes** is a complex and challenging task, often involving multiple conflicting objectives, such as minimizing costs, maximizing throughput, and ensuring product quality. Predix incorporates reinforcement learning and evolutionary computation techniques, such as genetic algorithms, to explore various process configurations and identify optimal solutions that balance these objectives. By modelling the industrial processes as Markov decision processes (MDPs) or multi-objective optimization problems, the software can learn optimal control policies or Pareto-optimal solutions that maximize the overall process efficiency and effectiveness.

Predix benefits from the integration of computer vision and natural language processing (NLP) technologies, which further enhance its capabilities in monitoring and optimizing industrial systems, for example to analyse visual data from cameras and sensors, enabling the platform to detect defects in products, identify potential hazards in the production environment, or monitor the progress of maintenance activities.

Similarly, NLP techniques can be used to analyse textual data from equipment manuals, maintenance logs, or operator notes, providing valuable insights into the operation and maintenance of industrial systems. By combining these insights with the information obtained from sensor data and predictive models, Predix can offer a comprehensive understanding of the state and performance of industrial systems.

3.4.15 Simcenter Amesim

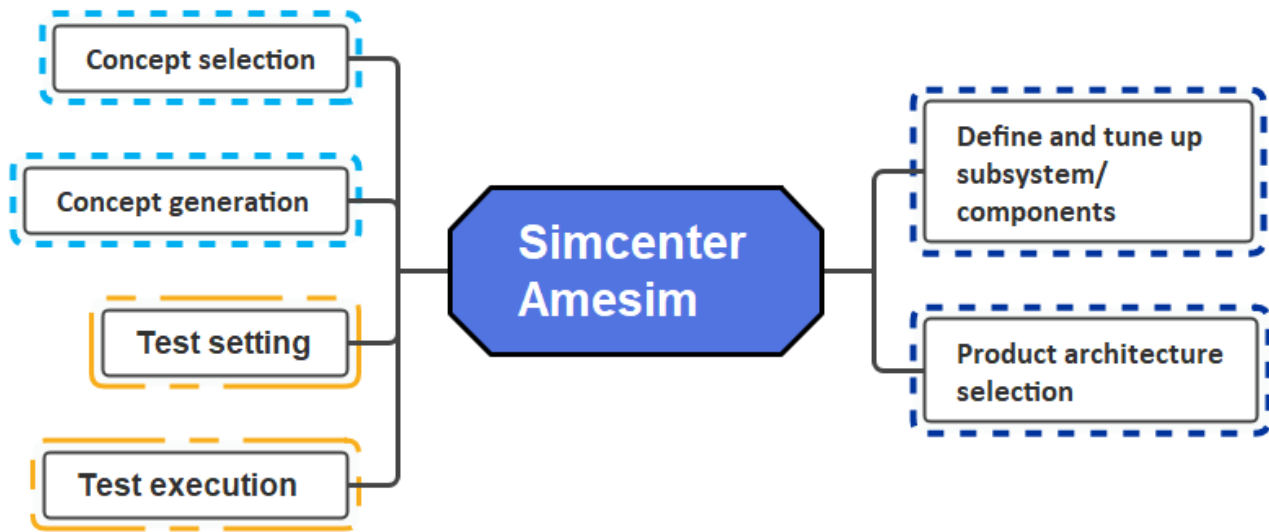

Siemens' Simcenter Amesim is a comprehensive simulation software platform designed to facilitate the modelling and analysis of complex multi-domain systems. It is extensively used in various industries, including automotive, aerospace, and industrial equipment, where intricate systems are required to work in harmony.

The AI-driven features of Simcenter Amesim can be categorized based on the AI branches outlined in this thesis, namely machine learning, neural networks, evolutionary computation, computer vision, robotics, expert systems, speech processing, natural language processing, planning, and large language models. In this section, we discuss how Simcenter Amesim leverages these AI branches to support design and innovation processes in product development.

Simcenter Amesim incorporates various *machine learning techniques*, such as supervised learning, unsupervised learning, and reinforcement learning, to improve the efficiency and accuracy of system simulations. The software can analyse historical data, learn the underlying patterns and relationships, and develop predictive models that can be used to forecast system behaviour under various operating conditions. These models can then be employed by developers to optimize system configurations, anticipate potential issues, and improve overall system performance.

Incorporating *neural networks*, Simcenter can develop sophisticated models able to simulate complex non-linear relationships between system components. By utilizing the inherent parallel processing capabilities of neural networks, the software can efficiently handle large-scale simulations and accurately predict system behaviour under a wide range of conditions, identifying optimal design solutions, validating system performance, and reducing the need for costly and time-consuming physical testing.

The tool also employs *evolutionary computation techniques* to optimize system configurations based on user-defined objectives and constraints. By simulating the process of natural selection, these algorithms can explore vast design spaces, identify trade-offs between conflicting objectives, and converge on optimal solutions that balance factors such as cost, performance, and manufacturability. Although not a primary focus, computer vision techniques can be integrated into the software to support advanced visualization and analysis of simulation results. By using image processing algorithms, product development teams can

analyze complex patterns and relationships within their simulation data, which can help inform design decisions, identify potential issues, and support the development of innovative products.

Simcenter Amesim can then be used to design and simulate *robotic systems*, incorporating AI-driven intelligent control algorithms and autonomous exploration techniques by modelling the dynamics, kinematics, and control systems of robots.

Expert systems can be integrated to guide through the simulation and analysis process. By incorporating knowledge-based reasoning and heuristic algorithms, these expert systems can provide valuable insights, recommendations, and best practices to help users optimize their system designs and improve product development outcomes. *Speech processing* techniques will also be added to the software in the close future to provide a more intuitive and engaging user experience, facilitating seamless communication between users and the simulation platform; along with *Natural language processing* (NLP) techniques, it will facilitate more efficient and easy documentation and reporting processes, automatically generating textual descriptions of simulation results, extracting relevant information from user inputs, and even responding to user queries in a conversational manner.

Simcenter Amesim already incorporates *planning algorithms* to support the efficient execution of simulation tasks and the optimization of system designs. With the employment of advanced optimization techniques and heuristic search strategies, the software can allocate resources, plan simulation tasks, and generate optimal design solutions that balance multiple objectives, such as cost, performance, and manufacturability.

With the recent developments in AI, the software could also be integrated with *large language models*, such as GPT-4, to enhance its natural language processing capabilities and support more advanced user interactions, exploiting the immense knowledge and understanding embedded in the aforementioned model to provide more context-aware and insightful recommendations, facilitate more effective communication with users, and even generate creative ideas and design suggestions that can drive innovation in the product development process.

3.4.16 Value Chain 2.0

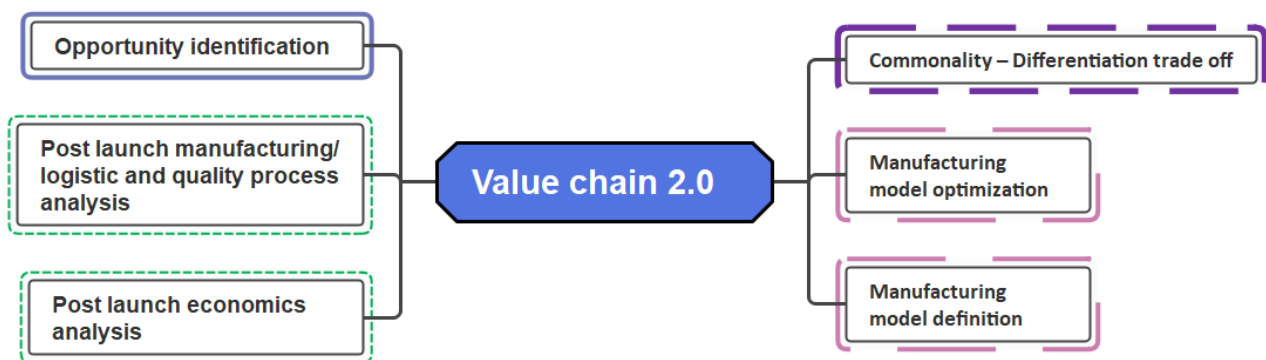

Value Chain 2.0 is an AI-driven supply chain optimization application to simplify and lower costs during product development. The software applies AI methods like machine learning, optimization algorithms and natural language processing to evaluate a vast quantity of supply chain data, pinpoint bottlenecks and recommend optimization strategies which eventually results in considerable improvements in the efficiency and cost-effectiveness of product development processes, leading to far more competitive and profitable products. Supply chain

management is vital to the general success of a product; an effective one entails timely delivery of materials, efficient sourcing and effective inventory control. Modern supply chains tend to be so complex that advanced AI technologies are required to optimize demand forecasting, supplier selection, transportation and inventory control.

Supply chain management faces challenges in forecasting demand and selecting the best suppliers. Value Chain 2.0 uses machine learning methods to analyze sales data and market trends, generating accurate demand forecasts. This helps in resource allocation, production planning, and inventory management, lowering costs and enhancing responsiveness to market fluctuations. Additionally, optimizing transportation using genetic algorithms and simulated annealing helps in minimizing costs, ensuring timely delivery of materials and finished products.

An effective inventory management ensures the appropriate quantity of materials and finished goods is readily available at the right time and location: Value Chain tool utilizes reinforcement learning to balance the trade-offs between stock-outs, overstocking and carrying costs to attain optimum inventory levels and replenishment policies, enhancing service levels and general efficiency.

In today's globalized business environment, product developers frequently work with suppliers and partners across different countries and languages. Value Chain includes natural language processing features to facilitate seamless collaboration and communication between team members, suppliers, and partners, regardless of their native language. By automatically translating documents, emails, and other types of communication, it reduces misunderstandings and allows for better collaboration.

Value Chain 2.0 can easily integrate with other tools in the product development cycle, including design optimization software (such as GenOpt), simulation tools (such as ANSYS) and data visualization platforms (such as Tableau). This integration allows product development teams to take advantage of the full potential of AI technologies, driving efficiency improvements and fostering innovation across the whole product development lifecycle.

3.4.17 Jaggaer

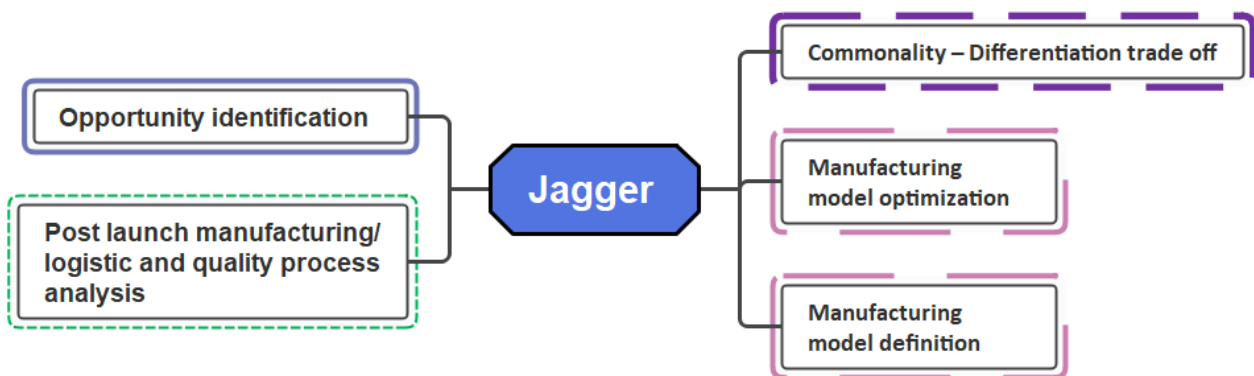

Jaggaer is an innovative AI-powered procurement and supplier management platform designed to assist in optimizing the sourcing, negotiation, and supplier management processes. In this comprehensive section, we will delve into the various technologies

employed by Jaggaer and how they contribute to the efficiency and effectiveness of product development.

Jaggaer's AI capabilities include machine learning, supervised learning, unsupervised learning, reinforcement learning, and natural language processing (NLP). Machine learning analyzes supplier performance data, identifying potential risks, and enhancing decision-making. Unsupervised learning groups similar suppliers, while reinforcement learning optimizes negotiation processes, reducing costs and aligning with project requirements. NLP helps analyze procurement contracts, identifying key terms, risks, and negotiation areas, reducing contract review time and effort.

Expert systems support supplier evaluation by assessing performance across cost, quality, and delivery, prioritizing critical relationships. Jaggaer uses computer vision technology for streamlined supplier onboarding, extracting relevant information from documents like business licenses, certifications, and insurance, reducing manual data entry errors and ensuring accurate and up-to-date information.

Jaggaer's platform also integrates robotic process automation (RPA) capabilities to further improve the efficiency of procurement jobs: by automating repetitive tasks, such as data entry, invoice processing, and purchase order generation, RPA makes it possible to focus on higher-value activities, such as strategic sourcing and supplier relationship management which ultimately results in more efficient and cost-effective product development processes.

3.4.18 GPT-4

The OpenAI GPT 4, large language model, is a powerful tool able to support product development during different stages. The innovative technology employs its natural language processing (NLP) and understanding capabilities to aid and boost product development efforts.

The subsequent sections assess the role of GPT-4 in facilitating different areas of the design and innovation process, displaying its potential to change product development practices.

In the ideation and concept development stage, GPT-4 could play a critical role in generating creative ideas and inspiring novel solutions, using its enormous knowledge base to evaluate existing products, market trends and customer preferences and suggesting new ideas to meet unmet needs or even enhance existing designs. Moreover, it can help in brainstorming sessions by offering a diverse range of ideas, helping teams think outside of the box and explore new possibilities.

GPT-4's language generation capabilities can also considerably simplify the process of drafting product descriptions, user guides, along with various other technical documentation, being able to automatically produce precise, succinct, and engaging content which properly communicates the value proposition of the product by analysing its features, functions, and target market.

The natural language processing abilities of GPT-4 permit to effectively process and evaluate a lot of customer feedback from different sources, which includes product reviews, social media reviews, and customer support requests guiding choices about product design, feature prioritization and advertising strategies by identifying trends and recurring themes, and eventually leading to enhanced industry fit and consumer satisfaction.

Product development projects usually succeed through good communication and cooperation. and the LLM could help facilitate this by acting as a smart intermediary between team members, enabling real time translations, summarizing discussions, and also, when used in combination with text to image plugins, producing visual representations of complicated and detailed ideas to close communication gaps, reduce misunderstandings and also make increase the alignment between members of different teams and therefore allowing a better coordination toward a common objective.

GPT-4's potential in product development is even more amplified when incorporated with other AI complete different A.I. branches and algorithms discussed in this thesis. It can deliver valuable insights into product performance, customer preferences, and market dynamics when utilized along with machine learning methods being supervised learning, unsupervised learning or reinforcement learning. These insights can direct design decisions and innovation efforts, eventually resulting in far more competitive and successful products.

It could also complement computer vision solutions to analyse visual information including, prototypes and images from manufacturing processes. which could reveal design flaws, streamline production and maintain product quality and consistency. Product development process may be further improved by the integration with expert systems making it able to make much more up to date recommendations, recognize potential risks and improve decision.

GPT-4 and other large language models are likely to get far more sophisticated and capable of addressing a broader range of product development challenges as the field of AI evolves. Continual advancements in research might end up in stronger language models that can comprehend context, reason more effectively, and also generate more creative and innovative ideas.

As mentioned in the second paragraph nowadays chat gpt4 allows plus users to implement different types of plugins, lowering the effort necessary to reach the potential of generally complicated and not particular user friendly A.I. tools. The variety of these plugins guarantees the application of GPT 4 chats in a boundless range of fields, from legal information support to prompt optimisation. Some examples of promising plugins are listed below:

Code Interpreter: this is probably the most outstanding, flexible and impacting add-on available today. It can basically automatically analyse, even when not guided, text of any kind and produce detailed graphs on any kinds. Moreover, its ability to autoanalyze immense database in a matter of minutes, without requiring specific indication on the method to use. It is worth to underline that, as happens with all prompts based A.I. tools, the greater the degree of detail of the input-indications, the closer will be the output to the user intention, hence in

more skilled hands it can really surpass the capability in terms of time and effort management of other type of data analysis instruments mentioned in this chapter.

An example of a prompt session using code interpreter to analyze an xls dataset.

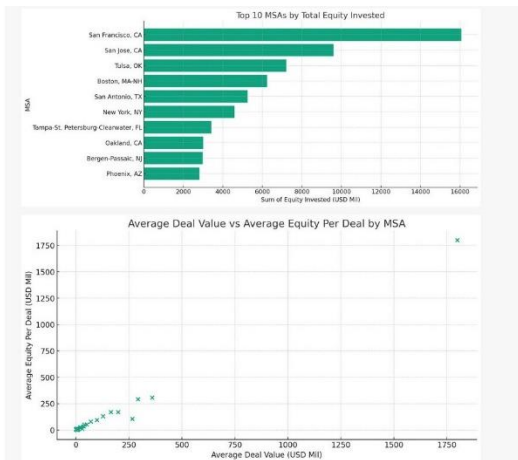

Prompt 1 Can you conduct whatever visualizations and descriptive analysis you think would help me understand the data?

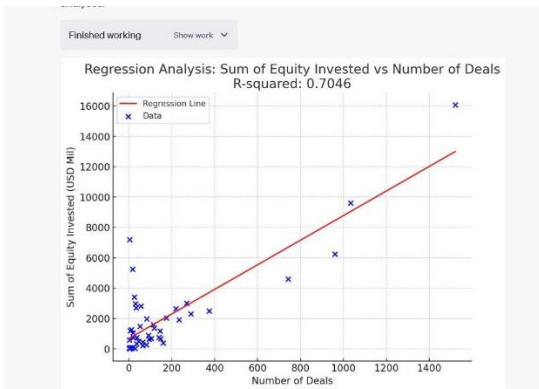

Prompt 2 Can you try a few regression analysis and look for interesting patterns?

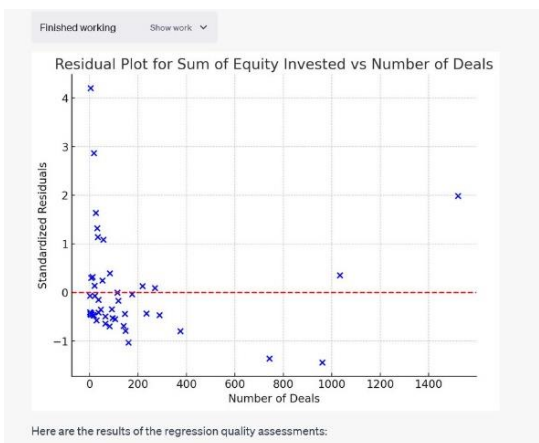

Prompt 3 Can you check to see the effect of any outliers on these regressions? And conduct any other regression quality?

Browsing mode even though this is not an actual add-in, it can enhance deeply the capabilities of GPT4 to gather data. In fact, by suggesting consciously links it is possible to concentrate all desired information in a single chat and, by interacting with it (and potentially use code interpreter functions) it is possible to quickly extract useful insights. However, the most immediate use of this new function is to concentrate in a single prompt what would have

required specific searches using normal search engines. It is in fact the latter that are particularly exposed to the possible substitution if not integrated by LLMs.

Fiscal Note: it can be considered as a narrower version of the browsing mode that can enhance the velocity of discovering new changes in the social, economic and law areas that could lead to the rise of potential opportunities. It acts like a personal press review capable of adapting to the field of interest.

Although GPT4 is able to recognize and train to build around each user's way of communicating, at this date it is still possible to witness "hallucinations" in the form of:

1. **Filling in gaps with incorrect information:** Sometimes, if the model does not have sufficient information to generate a response, it may fill in gaps with information that seems plausible based on its training but is actually incorrect. For example, if you ask it about a historical event that happened after its training cut-off, it might still generate a response, but this response could be completely fabricated. In practice, the answers can be conditioned by the LLM's perceived expectations of the questioner.
2. **Generating overly creative responses:** Sometimes, the model might generate responses that are overly creative or imaginative, especially if the prompt encourages it to do so. This can lead to the generation of information that is not reality-based.
3. **Confidently stating false information:** The model can sometimes make statements that are factually incorrect, yet it does so with confidence. This is because the model does not have a concept of "truth" or "falsehood"—it only knows how to mimic patterns in the data it was trained on. However, GPT4 can provide the textual/informative references used to answer the question appropriately, thus enabling verification of answers that appear less sensible and structured.

It is also possible to implement additional plugin, like Prompt Perfect, that can recommend prompt modification to simultaneously avoid this type of problem and obtain a mor effective prompt. Considering the strong modularity of the architecture that characterises chat GPT and its almost universal applicability, it is a transversal tool for the entire product development process.

4 Augmentation, support and automation of product development activities with AI:

Finally, this last section is devoted to a more practical/operational analysis of some more specific applications of AI within the product development process model under consideration. Some operations that can be carried out through the use of branches and reference models will then be examined in terms of the ways in which they can be made available to both decision-makers and operators.

The assisting applications of these tools are generally divided into three independent categories: automation, augmentation and support.

- **Support (SUP):** An application of a tool falls into this category when it does not directly control the decision-making or operational process, whose responsibility and control remain firmly in the hands of one or more groups of people. In these situations, the role of the AI is mainly to make part of the processes quicker and more efficient.
- **Augmentation (AUG):** Again, applications that fall into this category do not remove the work and responsibility of the human decision-maker, but rather support it. However, applications of this type perform tasks that a human decision maker generally cannot fully manage.
- **Automation (AUT):** Applications of this type, on the other hand, completely replace the responsibility of the human subject by autonomously carrying out the assigned process. Logically, this category tends to be populated by processes that are highly structured (and therefore have historical data to refer to) and predictable.

The decision to look at applications rather than individual branches and models is due to the fact that they cannot be clearly categorised. ML, as well as Evolutionary Computation, Computer Vision, Expert Systems, can be built to support some activities or to fully automate other less sensitive subtasks. It is the context in which it occurs that defines the category of appearance.

The table below summarises the main CoAs to which these applications refer, the category to which they belong and, finally, the level 2 phases in which they take place.

Lvl_1 phases	Lvl_2 phases	Main CoA involved	A.I. application	Branches_Model	Appl. category
Planning	Opportunity analysis	STR	Data analysis_Opportunity suggestion	LLM	AUG
	Product planning	STR	Optimization_Resource allocation optimization	EC_PSO + ANN	SUP/AUT
	Customer needs analysis	ID	Data gathering_custom survey generation	LLM	SUP
		CNTR	Data analysis_Explanation AI models for customer segmentation	XAI	AUG
Concept development	Product specifications definition	STR	Optimization_General feature optimization	EC_GA	AUT
			Datagathering_BoM auto update	ANN_MLN	AUT
	Concept generation	DEV	Generative design_image/3D model generation	LLM + ANN_GAN	AUG
	Concept selection	COM	Communication assistance_Augmented reality	CV	AUG
	Concept testing	CNTR	Generative design_image generation	LLM + ANN_GAN	SUP
System level design	Establishing the Architecture	STR/DEV	Optimization_General feature optimization	EC_GA	SUP
	Definition of the product variants				
Detailed design	Component/subsystem refinement	DEV	Optimization_Topology optimization	ANN + EC_GA	AUG
		CNTR	Optimization_Material property optimization	ANN_GAN	AUG
	Component/subsystem production plan definition				
Prototyping	Test setting	CNTR	Optimization_Material properties optimization	ANN_GAN	AUT
			Optimization_Topology optimization	ANN	SUP
Design for manufacturability	Manufacturing process modelling				
	Optimisation of the design for the manufacturing process	CNTR	Optimization_Topology Optimization	ANN + EC	AUT
Product review	Target market Response Analysis	ID	Data analysis_custom survey generation	LLM	SUP
	Post launch production performance analysis				

4.1 Generative design:

The generation of alternatives, as we have seen in Chapter 1, is a fundamental activity for the creation of a product capable of incorporating all the fundamental features linked both to the functional requirements deriving from the manifestations of the needs of the customers and to the technical specifications, not necessarily linked to an explicitly expressed set of needs, but related to the quality and safety that the product is able to guarantee.

In this respect, A.I. can be, and already partially is, integrated in the processes of generating concepts, primitive solutions, but also in the refinement and improvement of concepts already considered promising. Typically, the term "generative design" is used when an Artificial Intelligence system is tasked with creating new physical representations or descriptions of a product idea.

4.1.1 Image generation:

In sections 3.4.8 and 3.4.9, with reference to software such as fusion360 and Synera (but also Solidworks, Rhino and many others), generative design was introduced as a set of processes that use A.I. for generating new designs that are optimized with respect to a number of structurally significant variables. These processes will be revisited in the optimization section, but for now the focus is on generative design applied to the generation of generic and abstract concepts, so factors of a structural, thermal or physical nature are not generally taken into account.

One of the main objects useful both for the process of clarifying and externalizing the product idea of individuals or groups of designers, and for its preliminary realization, is represented by more or less detailed illustrations of the concept. Historically, this activity, which can be traced back to internal research (concept generation), the generation of opportunities (opportunity analysis), but also to systematic exploration (concept generation), was closely linked to artistic, technical and manual skills and the ability to interface with specific software. The so-called sketches and the first versions were made by hand, and at most digital tools such as digital tables and modelling programs (Blender, Rhino...) were used as supporting tools.

The advancement and refinement of techniques and architectures for constructing Machine Learning (ML) models have paved the way for an alternative approach to the traditional one. Specifically, the implementation of Artificial Neural Networks (ANNs), and in particular, Convolutional Neural Networks (CNNs), which are more adept at handling image data (grid-type data), has made it feasible to develop ML-based software. These software can autonomously understand and label different images, a process known as unsupervised learning. Furthermore, they can generate images based on the combination of embodied texts or texts that have already been processed by another type of ANN, typically a Recurrent Neural Network (RNN). RNNs, especially those in the Long Short-Term Memory (LSTM) category, encode the meaning and the relationship between the words contained in the text, and this information is used along with a set of random noise images to create new images.

With reference to what is defined in 3.4.10, the side that analyzes and recognizes can be defined as a discriminator, while the side that creates images is defined as a generator.

These tools effectively cut off any traditional manual artistic operation from the reference frame, making more relevant the datasets on which the different CNNs have been trained and

the designer's ability to understand and best express in natural language the relevant attributes of the concept, its relationship with the environment and all the particularities that makes it unique. However, it should be emphasized that the need for database training acts as the main limitation, since ML-based software can “only” be creative by emulating the images used in the training dataset.

Therefore, they are creative only with respect to elements that are already known and for which it is possible to have large amounts of data. They remain hardly usable in those few contexts where it is not possible to have a reference database for learning to recognize and reproduce styles, themes, environments and other specific features, to be defined during the definition phase of the training and which characterize each image in the database.

Below is presented a small simplified flowchart of a possible application of these tools within a process of generating a set of images that reflect one or more concepts.

Typical human activities are indicated in green, where the AI's intervention is completely negligible; in grey, activities that are almost completely automated; and finally, yellow circles, with a thin and thick border respectively, are indicators of the inputs and outputs of the process.

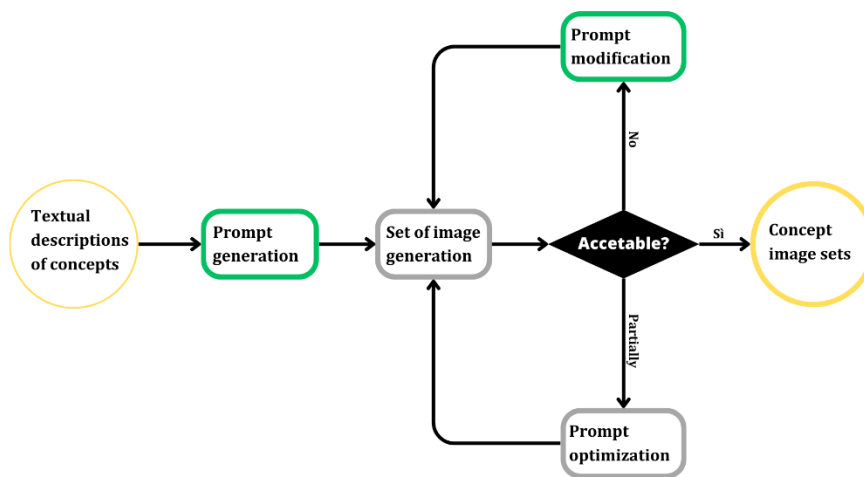

Figure 50 2D concept images generation flowchart

The beginning of this process consists of a brief description of the possible concepts, which, as we will see in section 4.3, can represent a real explorable opportunity, for example from the analysis of the responses of potential customers obtained from the provision of surveys.

The first step is therefore to create an initial prompt that expresses all the basic attributes that must characterize the concept. In itself, it is not essential to specifically firmly define a single value for each of these attributes; on the contrary, it is possible to systematically explore some concept ideas by trying to enhance each attribute in a different way. But the attribute classes, such as color, xyz size, image background, surface texture and many more, must be predefined by the designer.

Once this has been done, the A.I. takes care of creating the image according to the previously defined logic. Here the AI acts automatically once it has been sufficiently trained, and the designer can only define some characteristics of the generation process, such as the number of images that can be generated (the words within the prompt are almost never uniquely

interpretable), the quality of the image (i.e the pixel density of the image), the absence of subjects that can be associated with certain words, and other secondary elements.

At this point, a set of images is generated according to the given prompt. In general, if the generator has been trained on a sufficiently large dataset and contains features that can be associated with those requested in the prompt (if this is not the case, it is necessary to continue training by entering images that fill this gap), it is necessary to go on to refine the prompt, thus starting an iterative trial and error sub-process. The AI, in the form of Expert Systems (ES), can also suggest relevant criteria and their relative weighting, based on the similarities between the product development project for which you want to create a concept and previous projects, taking into account common objectives, sectors and reference markets.

The refinement of the prompt can be done both automatically, using specific extensions and programs that adjust the form, syntax, punctuation and spelling of the input prompt, and manually, so that the designer goes directly to editing as the prompt is written. In general, the second situation occurs when the set of images generated is enormously distant from the idea that the designer wants to express, and therefore requires a reworking of the values assigned to the various attributes, if not a change of the feature classes themselves.

In conclusion, image generation is undoubtedly a first step towards extending the processes of concept generation, concept testing (generated image can be used to support the construction of surveys), opportunity analysis (basically secondary) and its possible developments will continue to further modify the ways in which processes of this type are carried out.

4.1.2 3D model generation:

This process is nothing more than an evolution of the one described above. The logic remains almost unchanged, i.e. the designer provides a text input or an image of the concept and the AI can understand this input and generate an output corresponding to a 3D model, usually in STEP format.

Continuing with what was expressed in the previous paragraph, at this point the set of images is used as a reference for the generation of the 3D model or, more precisely, its reconstruction.

Reconstruction is automatic and the designer cannot modify the internal parameters of the ANN that controls the process, but can at most change the viewpoint of the image or the quality of the same.

The actual process of model reconstruction is complex, but can be divided into three basic steps:

1. **Generation of depth maps:** Potential viewpoints are selected that simulate the position of the camera in the three-dimensional space in which the 3D model will be reconstructed. The image is then projected from each viewpoint and the chromatic gradient of the image is used to define the relative distance between the points that make up the different parts of the image. To put it more simply, the basic components of the image are defined (essentially using what is known as computer vision) and then the areas of shadow and light (and therefore indirectly the positions of the light sources) are used to understand which parts are more or less distant from the common point of view. The information on the relative positions of the parts in space

is then stored and a sort of 3D prototype is created.

- Mesh reconstruction:** The depth map created in the previous point is used as input for this phase. The information about the relative position of the different parts is used to create a mesh, a sort of surface network that simulates the boundary of the body to be reconstructed. In fact, all the reference points present in the depth map are merged in order to then create others based on the acceptable level of irregularity of the surface. To carry out this phase, it is not uncommon to find the use of GAN models capable of measuring the level of accuracy of the reconstruction of the mesh.
- Reconstruction of the 3D body model:** This is the final step where the inside of the body is created from the mesh. This step is not generally relevant, but only for future engineering applications of the model, through common CAD, CAM, CAE software. The solid body is not created in a single step, but first the mesh is repaired (it is not always linear to define a surface that passes through a set of points), then the points of the mesh are transformed into voxels, i.e. three-dimensional pixels, then a new surface is recreated from the voxels (using an algorithm such as Marching Cubes or Surface Nets) and from this it is possible to reconstruct the solid body that represents the 3D model of the concept. There are several techniques, one of the most important of which is the Boundary Representation (B-rep). In a B-rep, the object is represented as a set of connected faces that form a closed volume. Each surface is defined by its boundary edges, and each edge is defined by its end vertices. This allows complex shapes to be defined accurately and is widely used in CAD software.

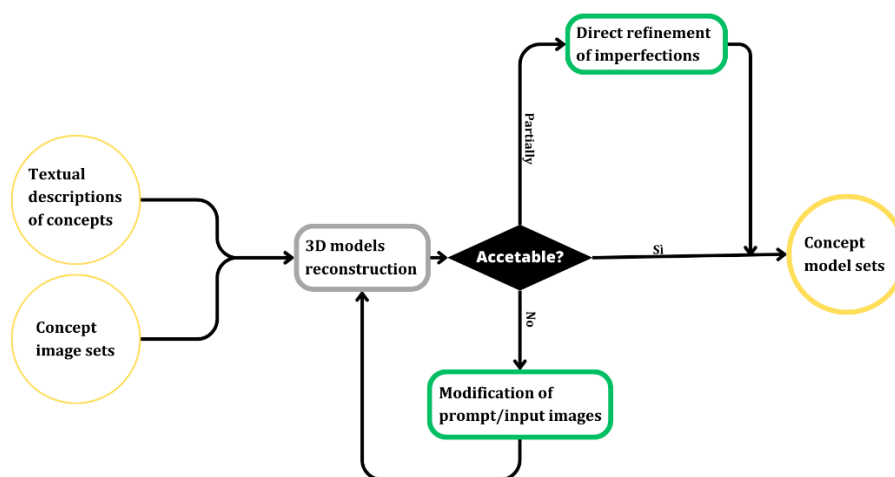

Figure 51 3D concept models generation flowchart

To date, there are only a few programs (DreamFusion, Blender are the most popular) that are able to carry out this operation and, in general, the actual ANN architecture underlying the two components of the GAN models is not yet public. The third point, i.e. the reconstruction of the internal body from the mesh, tends to require optimization operations that are difficult to trace back to patterns, so A.I. is not involved, but rather, for example, manual and appropriate modifications are made to the initial mesh in order to facilitate the reconstruction of the body

itself. However, this operation is only carried out in contexts where the model is to be used for engineering purposes, but more specific alternatives exist, as highlighted in 3.4.8 and 3.4.9.

In general, the conclusions about the nature of the use of AI in these processes do not change, since here too it works alongside the designer, carrying out calculations and operations that a human being can hardly perform, so in this case too we can speak of augmentation. On the other hand, the impact on the product development process of embedding processes that combine AI and human capabilities to create 3D models is certainly greater than that of image generation (but it is not negligible).

4.2 Optimization:

Optimization is an almost constant element within all activities competing for product development. In this subchapter, it is defined as the process of progressively approaching an optimal solution capable of minimizing or maximizing a set of objective functions characterizing a problem defined by a set of variables. In general, in optimization the problem to be dealt with is known in all its fundamental variables and solution schemes exist which, however, do not present closed solutions and therefore require several executions before being able to converge to an acceptable solution. Another case of optimization problems occur when the optimal solution is known but it is not possible to define the set of functions which, starting from the inputs, is able to converge to that solution.

A.I. is particularly effective in these two situations.

Through the implementation of ANN (but Expert systems are also used in this regard), A.I. is able to approximate the solution function and optimize its behavior (i.e. its set of the weights) generally by using gradient descent algorithms. These ANNs can then be used unsupervised in analogous contexts where the optimal solution is no longer known, and the solution scheme is already perfectly approximated by them.

In the case where the optimal solution is not known in advance, but the solution scheme is, it is possible to activate Evolutionary Computation procedures, which generally provide for the iterative and self-guided execution of the solution steps of the problem until the solution converges.

This last aspect is particularly critical, since problems characterized by a high number of interrelated variables lead to a proliferation of potential local solutions, which do not necessarily represent the optimum. Also, the brutal (i.e. without create rules to select inputs) exploration of all potential local optima collides with the computational limits of machines capable of effectively performing the calculations necessary to identify them. Consequently, evolutionary computation, and genetic algorithms in particular, are designed to refine the choice of inputs to the solution process based on the definition of one or more reference fitness functions capable of reflecting the quality of the approximate solution.

4.2.1 Topology optimization:

As introduced in sections 3.4.8 and 3.4.9, the applications that use topological optimisation focus on purely engineering aspects, where the problem is not so much to define the shapes of the different parts as a direct function of the customer's preferences, but rather to construct an optimised physical-analytical model with respect to the conditions that are assumed to reflect the contexts of use of the final product.

It is not exactly a matter of generating real concepts, since the necessary information, such as the material, the environmental variables and the maximum size, must already be defined.

In this context, ANNs can be used to create surrogate models that approximate the relationship between design variables and simulation outputs (such as stress or displacement). These surrogate models can be trained on one set of simulation results and then used to quickly predict the results for new sets of design variables. This is particularly useful not directly for the refinement and correction of problems associated with a model, but rather for the actual simulation of the behavior of the model in the context of use, which is traditionally performed with FEM simulations. In this respect, it is immediately emphasized that the fundamental limitation that characterizes the application of ANN is its impossibility to replace traditional FEM techniques. ANNs can only be added to them, speeding up the prediction of the relationship between input (stresses embodied by the model) and output (model displacement) in the most defined contexts, where there are vast databases on which to build the functions linking the various layers of the ANN. But they don't open up new, more accurate ways of approximating the relationships between inputs and outputs.

In this sense, they support the work of engineers and do not increase their capabilities, and certainly do not automate it, since the stability of the functions linking inputs and outputs in the structural, thermodynamic, electronic/electrotechnical fields is highly sensitive to the choice of inputs.

Topology optimization, as the optimization of the model after appropriate simulations and specific studies, is more closely related to the world of evolutionary computation. The main algorithms used are the so-called genetic algorithms, which simulate the adaptive behavior of nature in the different application contexts according to a mechanism defined in 2.3. Due to the high intensity and heterogeneity of the possible configurations that can be assumed by the different input populations, topology optimization operations are characterized by a high effort in terms of the necessary computational power.

To minimize this, hyperparameter optimization techniques are used, which modify the internal parameters of the GAs to minimize this effort. Examples of internal parameters are population size, mutation rate, crossover rate and selection methods.

Notwithstanding the limitations and technical issues of these situations, the AI works synergistically with the human designer to produce 3D models that would otherwise be unattainable. The continuous iteration between designer and machine makes it possible to create physical models of the product that are simultaneously efficient in terms of mechanical performance, material distribution and, indirectly, production costs.

4.2.2 General feature optimization:

If in the previous case we considered an application of a more engineering nature, where the essential thing was to construct a model that was reliable from a physical-analytical point of view, here we are looking at the optimization of a product model according to characteristics that are more abstract and linked to variables of a more economic nature,

The main reference for this section is the application of the Non-Dominated Sorting Genetic Algorithm II (NSGA-II), i.e. a particular type of GAs capable of generating optimal and as different as possible solutions in the presence of multiple discontinuous, non differentiable, stochastic or highly non-linear problems. An example can be found in Kwong C.K. et al. (2015)

[46], where this algorithm was applied to determine the optimal characteristics of an iron. The optimization in this application is guided by two fundamental drivers, namely the market demand M_d and the profit P_f , which results from the introduction to the market of an iron characterized by a specific combination of features.

The first part of the paper formalizes the models that define the two drivers according to the product design variables. For this purpose, AI is applied according to the logic of fuzzy regression systems. Fuzzy regression is a method used to model a relationship between variables when the data is imprecise or fuzzy. It's often used when the data is not crisp (i.e. exact), but rather has a degree of uncertainty or fuzziness. These are not true optimization models, but are used to help manage the uncertainty associated with the input data, which is then used in the real optimization process. In this article we can find an example where reference variables (Activeness A , Quality Q , Functionality F , User-friendliness (U_f), Price (P), Cost (C), Utility (U)) are modelled by these models and from these estimates we derive the two drivers that guide the definition of the optimal product configuration.

In the second part, on the other hand, the actual optimization takes place, following the logic of the other GAs, with the main difference that here the fitness functions incorporated by the drivers are of a completely different nature and the optimization process does not consider the technical and physical designs, but a set of possible configurations of the different parts that make up an electric iron. In fact, the authors are able to compute the optimal combination that maximizes both fitness functions on the basis of a continuous modification of the representative populations of certain configurations of the features.

Contrary to the previous specific case, here the AI does not work in synergy with those decision makers who have to decide which architecture has the best characteristics. Rather, its application is supportive, as it allows the efficient execution of computationally demanding sub-processes, but there is no direct interaction and input-output exchange between the two parts.

4.2.3 Material properties optimization:

Forecasting the properties of a material is one of the fundamental elements in the development of physical products, especially in more technical and physical development areas, where the technical performance is the main driver for the good success of the product in the market.

In this paragraph, reference is made to an article by Zijiang Yang et al. (2018) [47], where a procedure is implemented that simultaneously involves GANs for the generation of images of representative microstructures of the material to be tested, Gaussian process metamodeling, which allows to define the relationship between the characteristics of the microstructure (design variables) and the behavior of the material (performances/goals) according to a Gaussian type scheme, and finally GP- Hedge Bayesian optimization, which, starting from the approximate relationship between design variables and performance/objectives, defines classes of image clusters of microstructures that are significant for refining the relationship between design variables and performance/objectives (exploitation) and others to support the definition of relationships that are weaker and more uncertain (exploration).

Thus, in this application, on the basis of a database of 5000 images of microstructures, the GANs are able to reproduce new images with characteristics (i.e., design variables) similar to those present in the training database, thus increasing the input data for the optimization carried out by subsequent models. This is necessary for the correct functioning of the subsequent GP models, which by their nature require large amounts of data on which to build the approximations of the relationships.

Contrary to the cases described in 4.1., here the GANs only have the task of automating the generation of images to support the optimization, and there is no real control by the material selection manager, who can at most modify the training database used and thus directly modify the internal parameters of the model.

Similarly, to the optimization process described in 4.2.2, here too there are no major interactions between the decision maker and the machine, except those that radically modify the optimization models themselves. The direct process thus defined can therefore be used in analytical prototyping to help define the behavior of a material in the context of the use of a prototype.

In conclusion, the application of an inverse process can be just as effective in detailed design phases, since the AI is potentially able to define the microstructure of the optimal material, starting from the definition of a set of performances, within the limits of the image and data sets used to carry out the training. Contrary to the direct application, here a greater interaction between man and machine is plausible due to possible problems, for example, related to the impossibility of realizing a certain microstructure due to the lack of adequate means and knowledge, which would necessarily lead to iterations of the process aimed at eliminating all the unacceptable solutions that can arise.

4.2.4 Resources allocation optimization:

In a complete departure from the more engineering and creative contexts that characterized the previous paragraphs, this is once again an application of algorithms belonging to the GA family, but relative to the scope of product development project planning, according to a project management approach. Optimization is therefore no longer intended in terms of

design variables, but in terms of specific choices regarding the allocation of human resources and the prioritization of the execution of activities. Also in this case, we consider a reference case study present in the literature (Ming Lu et al. (2007) [48]), in which a different model of GA is used compared to those seen previously, namely the PSO algorithms. In the context of project planning, as discussed in the article, the SDESA platform is used to simulate the project based on a given planning solution. Each potential solution, represented by a particle in PSO, is evaluated using a fitness function, which in this case is the total project duration. The objective of the PSO algorithm is to find the particle (i.e. the scheduling solution) that minimizes this fitness value.

In PSO, each particle updates its velocity and position based on its own best position so far (P_{id}) and the best position found by any particle in the population (P_{gd}). The updated position represents a new potential planning solution. The SDESA platform simulates the project based on this new solution and the resulting total project duration is used as the new fitness value of the particle. This process is repeated until certain stopping criteria are met. The best position found by each particle throughout the process is considered the optimal scheduling solution. In contrast, NSGA-II, a type of genetic algorithm considered in 4.2.2, represents potential solutions as chromosomes. New solutions are generated by crossover (recombination of two parent chromosomes) and mutation (random changes to a chromosome). Individuals are then selected for the next generation based on their fitness and diversity using a process called non-dominated sorting. The choice between the two is not immediate and is guided by practical considerations. In this case, the use of PSOs was chosen because of their greater accuracy and speed of convergence, although this depends on the application context.

This makes the simulation process simpler and less expensive at the computational level, but less effective in more complex contexts where, for example, the duration of activities, uncertainty about the availability and quality of resources, and risks external to the project become more important. Apart from possible model complications resulting from the use of data subject to statistical fluctuations and uncertainties (which have a solution similar to what was expressed in 4.2.2.), PSO algorithms also focus on reaching out the optimal (unknown) solution given a well-defined solution process. In this article, this is done by using coefficients (taken from the specific literature) and the rule of thumb to calibrate the velocity model so that the individual particles have a reference to improve their convergence trajectory towards the optimal solution. The velocity model is the compass of the optimization process of each particle. However, it depends on secondary parameters that are at the heart of the model, such as the number of particles within each simulation, c_1 and c_2 , called cognitive and social parameters, which, as mentioned above, are assigned in a preventive manner. From this point of view, this application can be considered as a mere support.

But an application of ANN can potentially define, on the basis of the accuracy of the predictions proposed by the PSO and the context of application of the problem (number of tasks, task hierarchy, available resources, recruitable resources...), the best internal parameters to use. Imagining the creation of such an auxiliary superstructure, the interaction between the AI and the project manager can become secondary and the latter's responsibilities would depend more on the choice of projects to be considered in the portfolio, also on the basis of the scheduling and allocation of resources carried out automatically by the AI.

4.3 Data Analysis:

Data analysis is considered to encompass all operations that involve handling data with the objective of organizing it in a manner that is most beneficial for comprehending the problem at hand. In this section we want to show the use of AI not only in terms of its ability to classify, cluster and generally manipulate large databases, but also in relation to other branches and tools.

The positive impact of ANNs, but of ML in general, on the performance of these tasks is already well established, and in literature, it is possible to refer to direct applications of these techniques. For example, in Rajat Gera (2023) [49] it is possible to find a wide use of these tools within the fields of marketing, especially in the world of social media marketing and market research. Therefore, within this subchapter, the application of AI tools has been highlighted that make use of more recently developed models and branches, but which have been considered relevant for their ability to interface more effectively with the activities carried out by the human decision maker, compared to traditional cases.

4.3.1 Explanation AI models for customer segmentation:

The first case of great interest comes from XinHu (2023) [50], where the problem is not so much the accuracy of the work of the AI, or its speed of convergence, or its sensitivity to the perturbations of the input data, but rather the ability to interface correctly with the AI.

The process is divided into two phases. In the first stage, an AI model is developed and refined based on XAI explanations. The customer's raw data is collected, prepared and then used to develop an initial AI model. This model is then refined using feature-based and data-based explanations provided by XAI. Feature-based explanations help identify the relative contributions of different input features to an AI prediction. Data-based explanations, on the other hand, explain the impact of different data instances or data sets on the AI prediction. In the second stage, the refined AI model is used to make predictions about customer segmentation. The model is adapted to different contexts with specific requirements and constraints. For each unlabeled data instance, the model outputs a customer segmentation prediction along with several local feature-based explanations. These explanations are then visualized and presented to designers in an interactive manner, enhancing the designer-AI interaction and increasing collaborative trust.

The authors conducted an experiment to evaluate the effectiveness of the proposed framework. They used a dataset containing customer data instances with different characteristics. The AI was tasked with dividing these customers into two segments: low-income and high-income. The experiment showed that the AI model, which was refined based on high-quality datasets, showed continuous performance improvement.

In the light of this proposed example, the interaction between the market analyst and the machine is such that a dialogue is created between the parties, thus constituting a pre-emptive augmentative application.

4.3.2 Opportunity suggestion based on data survey:

As in the previous case, the focus here is not so much on the working mechanisms of the AI in its data synthesis and processing operations, but on the possibility of combining it with other types of models that make the interaction that an analyst can have with them easier, more accessible and more understandable. In particular, a synergistic application of different AI

tools is considered here, for opportunity generation, based on text classification of the responses to a survey designed to evaluate the most promising features of a product. Therefore, the responses from the surveys are first collected and pre-processed using functions available in open-source libraries, of which Pandas is one of the main references. For example, pre-processing can consist of filling in missing values or converting categorical variables into dummy variables. This is followed by the actual text classification, which is a machine learning technique used to classify text into predefined classes. This involves training a model on a dataset of text documents and their associated labels. The model learns to associate the textual features with the labels. Once trained, it can predict the class of new, unseen text documents.

This is where the latest developments in LLM come in, of which GPT4 is one of the main exponents, i.e. models that have already been trained and are able to understand, read and process texts written in natural language. There is therefore no longer an almost insurmountable obstacle posed by the lack of a model that has been trained on an infinite number of texts and that can be used in different types of contexts. In addition, there are already open source libraries, of which LangChain is the most important in this case, that provide basic elements for the creation of applications that interface with these LLMs, taking advantage of their capabilities to perform very specific tasks.

One application of LangChain was to use the typical functions of LLMs to perform a text classification, which is visually translated into a network of connections between words, where the connections between two words are all the denser the greater the correlation between them in the different periods of the survey responses. On the basis of this network, LangChain is able to call up other functions that make it possible to define the types of links that necessarily lead to their clustering. These clusters represent recurring themes within the survey responses. Already at this point, a data scientist is able to indirectly determine what may be the best responses to the text classification results.

The third and final point is the implementation, again through LangChain, of a simple and intuitive interface through which the analyst can access the knowledge generated by the LLM. Again, with LangChain it is possible to create a chat-style interface. This is another fundamental step towards being able to easily use the results of these LLMs, and therefore also fundamental for the diffusion of these models. In fact, if up to the second step one could speak of automation or support (depending on the stability of the connections between the words), with the implementation of a chat interface it is possible to establish a relationship of continuous exchange of information and requests between machine and human. One of the main uses consists precisely in pivoting on this interface to facilitate the identification of opportunities linked, for example, to the presence of recurring words and themes and linked to the dissatisfaction of a series of needs by some clusters of the respondent population. It is worth repeating that, in principle, this is already possible in Step 2 from the point of view of an expert, but the main impact of the implementation of chat-style interfaces lies precisely in the possibility of making it accessible to those who do not have extremely developed skills in the field of data analysis.

4.4 Data gathering:

The last subchapter always considers ANN applications, in the form of LLMs or others, but aimed at favouring and automating data collection operations. Compared to the other phases,

this one is less difficult from a conceptual point of view, but not of secondary importance. It deals with more direct, practical and automatic applications than the others considered previously. In particular, we will consider a first application that is related to what happens in 4.3.2, while a second one can be traced back more generally to the operation of improving the specifications of the components following the definition of the details of the product.

However, in Rajat Gera (2023) [49] there are also references to data collection in the field of social media marketing and the like, which are the cradle of absolutely non-secondary applications of these tools. It should be noted, however, that data collection in these contexts does not involve the use of ANNs, but the analysis part is rather guided by their use, in particular the use of LSTMs, which are ideal for processing sequential data, such as the words contained in a review or post on a given topic. In this sense, we find the dynamics of analysis considered in the previous paragraph, with possible variants such as that of sentiment analysis. There are other reference cases that look at other metrics, such as those of engagement, from which it is possible to start customer segmentation processes again, for example according to the most popular pages and with which there is greater interaction, but which are not dealt with directly.

As with the other applications, the main driver for choosing one model over another is the type of data being processed and the purpose of the processing.

4.4.1 Custom survey generation:

Application of Language Learning Models (LLMs) in survey creation is a demonstration of their transformative potential and their role in transforming the artificial intelligence landscape. As a helpful tool, LLMs may considerably improve the process of crafting surveys, enabling copywriters to design much more insightful and highly targeted questionnaires.

The journey starts with the copywriter defining the fundamental attributes of the survey. The survey should consider different factors like the thematic divisions, the nature of queries in each division and the tone and style of the questions. Furthermore, the copywriter also outlines the primary goals of the survey, basically what they aim to unravel or even comprehend from the responses. The LLM's task is based upon this preliminary input.

The LLM prepares a proposal for the survey after getting the initial guidelines. Nevertheless, the proposal isn't a monolithic suggestion, but a spectrum of alternatives for various segments of the survey. Each alternative is supplemented with a justification, elucidating the logic behind the different choices. The copywriter will then comprehend the reasoning behind each proposal and make a sound choice.

The copywriter and also the LLM have a cyclical connection. The copywriter then refines the original guidelines based on LLM proposals, and the LLM subsequently produces brand new proposals based on the modified guidelines. This iterative process goes on until the copywriter is sure that the most optimum survey has been crafted.

This methodology embodies a type of augmentation, where the LLM enhances the copywriter's capabilities, enabling them to develop a better survey. The copywriter always holds the final say. The LLM is a tool that compliments human discretion and expertise. The copywriter can modify the survey structure directly in case they feel it will accelerate the process or create better results.

The copywriter might modify the order of questions in an aspect based on their understanding of the target audience or rewrite a question to boost its curiosity. Conversely, the LLM might recommend alternative ways to phrase a question to minimize bias or even recommend introducing a new section to collect much more precise data.

Essentially, the application of LLMs in survey development is a promising advancement, providing the chance to enhance the quality of surveys and make the process more effective. Its application is what decides its effectiveness. The secret to success is a cohesion between the copywriter and also the LLM, merging their strengths to obtain the very best result. The LLM broadens the skills of the copywriter by offering a range of choices and explanations they may not have considered otherwise. The copywriter has complete discretion over the procedure and can intervene and make alterations as necessary. This method is really powerful as it blends human intuition with machine intelligence.

4.4.2 BoM missing features auto-update:

Synthetic Neural Networks (ANNs) have shown to be instrumental in anticipating properties in a Bill of Materials (BOM). A BOM is crucial in physical product creation and is basically an extensive inventory listing all parts, raw materials, assemblies and sub-assembly. Some features in the BOM might be lacking or incomplete. Multilayer Perceptrons (MLPs) could fill up the gaps created by ANNs. Feedforward ANNs such as MLPs are especially skilled at handling tasks involving prediction utilizing historical data. They generally have an input layer, 1 or more unseen layers and an output layer. The network learns by modifying the values of the connections depending on the accuracy of its predictions for each layer, which are nodes or "neurons" interconnected.

Let us say we have a physical product like a bike in a BOM. The BOM could consist of several components - frame, pedals, wheels, grips - and so forth. Each of these components would have associated features as material type, lead time, supplier, cost, weight, etc. Now, consider that a few of these features are lacking - maybe the weight of a brand new kind of pedal or maybe the price of a recently found handlebar. The MLP may be trained on past BOM data where all these characteristics are recognized. Neurons are set up in 2 layers to represent recognized characteristics of each element, and neurons would be arranged in the input level to represent the characteristic we wish to predict. Hidden layers would be trained to recognize intricate links between recognized features and the feature to be anticipated.

The MLP can predict the lacking features of new components based on their recognized feature sets previously trained. It can compute the mass of a brand new pedal based on its material composition as well as dimensions, or it might compute the price of a brand new handlebar based on its materials composition, supplier as well as delivery time. Previously, experts would manually estimate or investigate missing features in a BOM if they came across missing values - a time intensive as well as error prone process. The application of MLPs makes this particular task very easily automated, considerably reducing effort and time needed.

Additionally, the MLP can enhance automation by constantly processing brand new BOM data and thereby study as well as improve its predictions in the long run. MLPs may learn continuously so that the system is flexible and effective even as the dataset changes. Essentially, using MLPs in predicting missing BOM features represents a significant step towards the automation of this aspect of product development. MLPs automate the process of

finishing missing values, freeing up human experts to carry out more strategic as well as challenging jobs, enhancing overall efficiency and productivity.

4.5 Communication assistance:

The A.I. is not just a means of solving, optimizing and suggesting new possibilities that have not yet been explored. It is also a medium that can greatly facilitate communication between stakeholders and active members in the development of a product. Communication can take place not only in the verbal or written sense, but also through the simplification and visualization of purely analytical and numerical data. As has already been said between the lines in the various paragraphs, in particular in 4.3, the ability of the AI to make the solution process and the impact of the variables on it clearer is already a significant milestone in terms of communication. In general, the technological evolution of chat tools such as ChatGPT, although sometimes not optimal, is such as to allow their possible implementation in work databases shared within the organization. The possibility of interacting with them using natural language leads to a potential help in the communication of technical results between teams with different responsibilities, often characterized by complementary but different skills, and therefore not necessarily able to interact fluently in the exchange of technical information for the progress of the project.

Unfortunately, these tools are very recent, so the practical applications of these tools are still few and generic. There are prototypes of these applications built using the LangChain library, but they are still quite immature.

For this reason, the generic application of AR has been considered, intended as a tool capable of enhancing precisely the perception that a user cannot naturally possess. Practical examples of these applications can be found in some AR viewers/helmets, which differ from VR (Virtual Reality) viewers in that they do not isolate the user from reality, but add layers in the form of information arranged within the interface of the viewer itself.

4.5.1 Augmented reality:

AR could be a helpful communication tool which produces an immersive, interactive experience which links various stakeholders and also improves their understanding about the product.

The usage of AR overlays electronic data onto the actual physical environment of the user in real time, enabling them to interact with it intuitively and naturally. This may entail overlaying 3D models of a product onto the user's environment to enable them to see, manipulate as well as examine the product actually. The product could be better understood and described using this technique than via conventional 2D drawings or computer models.

AR is an incredibly helpful tool for designers as well as engineers for recording and interacting with their designs. They can see their models in 3D, at a precise scale, and inside the user's immediate surroundings. The models could be altered, enabling them to test out different design choices, and instantly see the effect of the modifications. It will help them understand the design better, encourage creative problem solving and expedite the design process.

AR can provide manufacturers a lucid, unbiased view of the product and its assembly procedure. They can examine the way the components fit together, spot possible problems and

experience the assembly process firsthand. This can bring down errors, boost efficiency and make sure that the product is made properly.

AR is able to provide marketers and end users an interesting, interactive experience in looking into a product. They can experiment with various options and experience the product in their own individual environment. The information acquired by this could boost their knowledge of the product, improve their participation and allow them to make much better decisions.

Additionally, AR allows remote collaboration among stakeholders. The same AR model can be viewed as well as modified simultaneously by users in various locations, enabling them to talk about their concepts and make adjustments in real time. The product development process could become more nimble and effective since stakeholders can work successfully wherever they are in the world.

AR has numerous advantages but also challenges, it has to be noted. The technology continues to be changing, along with issues persist in usability, compatibility, and security. The technology might not be familiar or at ease with all stakeholders, and adoption may call for a learning process.

5 Conclusions:

This thesis embarked on an exploration of the intersection between artificial intelligence (AI) and product development, presenting a comprehensive framework that associates AI branches, models, and algorithms to each phase of product development. It's important to acknowledge its limitations. The thesis does not take into account specific industries, each with their unique challenges and contexts. Although commercial software and real and theoretical applications have been used to demonstrate the actual utilization of AI in product development, a more in-depth analysis of the possible architectures and their correlation to the type and presence of labelled data is necessary.

Despite these limitations, the thesis has successfully demonstrated that the capabilities of AI find a significant place in product development. Certain branches of AI, such as Natural Language Processing (NLP) and Large Language Models (LLMs), are more involved in the strategic and marketing phases. Others, like Evolutionary Computation (EC), are more focused on actual development and engineering phases. However, the overarching conclusion is that every branch of AI can be utilized, albeit rarely in isolation, to solve the problems involved in the different phases of product development.

Moreover, these AI technologies can be implemented in various ways within the workflows of organizations involved in the product development process. The growing interest and advancements in AI are evidenced by the countless articles dealing with problem-solving using AI. While most of these articles are not directly concerned with product development processes and are more related to core business production, they provide valuable insights into possible utilization of models and branches related to those articles into product development problems. Looking forward, the future of product development is bright and full of potential. As the power of AI continues to be harnessed, it is not only improving processes but also enhancing human capabilities. The evolution of AI is not about replacing human intelligence but augmenting it. AI tools can take over routine tasks, freeing up humans to focus on more complex and creative aspects of product development. This symbiotic relationship between humans and AI will lead to improved quality of work, fostering a more innovative and efficient environment.

In conclusion, while this thesis has its limitations, it serves as a stepping stone towards a deeper understanding of the role of AI in product development. It is an invitation to further explore and experiment with AI technologies, to push the boundaries of what is possible, and to continue to evolve processes and human capabilities. The journey of integrating AI into product development is just beginning, and the future holds exciting possibilities. As learning, adaptation, and innovation continue, there is no doubt that a significant transformation in the field of product development will be witnessed, powered by the incredible capabilities of AI.

6 Bibliography/sitography

1. <https://www.cnn.com/2018/03/29/tesla-recalls-123000-model-s-cars-over-potential-power-steering-failure-reports.html>
2. https://money.cnn.com/2011/11/11/autos/volt_crash_fire/index.htm
3. <https://www.bcg.com/publications/2016/automotive-retail-digital-reroutes-auto-purchase-journey-oem-strategies>
4. <https://www.neuralconcept.com/post/challenges-in-generative-design-for-automotive-ev-industry>
5. A. Bertoni, S. K. (2018). MODEL-BASED DECISION SUPPORT FOR VALUE.
6. Aman Jantan, A. E. (s.d.). Aman Jantan, Abiodun Esther Omolara, Kemi Victoria State-of-the-art in artificial neural network applications.
7. Bender, M. P. (s.d.). Deep reinforcement learning in production.
8. Bylund, N. (s.d.). CONCEPT SELECTION IN THE AUTOMOTIVE.
9. G. Pahl, W. J. (2007). *Engineering design*. Springer.
10. Gaglio, C. M. (n.d.). *Opportunity Identification: Review, Critique, and Suggested Research Directions*".
11. Janmejay Bhardwaj, A. Y. (2021). Kano model analysis for enhancing customer satisfaction of an automotive product for Indian market.
12. Lagaros, N. A. (2019). DL- scale: Deep learning for model upgrading in topology optimization.
13. Lagaros, N. A. (s.d.). MLGen: Generative Design Framework Based on Machine.
14. Laurence Turcksin, A. B. (2011). A combined AHP-PROMETHEE approach for selecting the most appropriate policy scenario to stimulate a clean vehicle fleet,. *ScienceDirect*.
15. LeCun, Y. B. (2015). Deep learning.
16. Lorentz, V. &. (2014). Lorentz, Vincent & Wenger, Martin & John, ReinElectrification of the Powertrain in Automotive Applications "Technology Push" or "Market Pull"?
17. M.M. Davoodi, S. S. (s.d.). Concept selection of car bumper beam with developed hybrid.
18. Marco Cantamessa, F. M. (n.d.). *Management of Innovation and Product Development: Integrating Business and Technological Perspectives*. Springer.
19. Nicole Viola, R. F. (2023). Research, development and production costs prediction parametric model for future civil hypersonic aircraft.
20. Prorok. (2018). Graph Neural Networks for Learning Robot Team Coordination.
21. Qiming Zhu, Z. L. (2021). Machine learning for metal additive manufacturing: predicting.

22. Russell, S. J., & Pearson Education Limited. Sutton, R. S. (2018). Reinforcement learning: An introduction.
23. Sandro L. Vatanabe, T. N. (2016). Topology optimization with manufacturing constraints: A unified projection-based approach.
24. Sangeun Oh, Y. J. (2018). Deep Generative Design: Integration of Topology Optimization and Generative Models.
25. T. Ulrich, S. D. (2012). *Product Design and Development*. McGraw-Hill Irwin.
26. Ugo Ibusuki, P. C. (s.d.). Product development process with focus on value engineering.
27. Zeyu Zhang, Y. L. (2021). TONR: An exploration for a novel way combining neural network.
28. Zhang, J. L. (s.d.). Efficient Aerodynamic Shape Optimization with.
29. Zijiang Yang, X. L. (2018). Microstructural Materials Design via Deep Adversarial.
30. Hiyam Adil Habeeb, Dzuraidah Abd Wahab, Abdul Hadi Azman and Mohd Rizal Alkahari, Design Optimization Method Based on Artificial Intelligence(Hybrid Method) for Repair and Restoration Using AdditiveManufacturing Technology
31. Marcel Panzer & Benedict Bender (2021), Deep reinforcement learning in production systems: a systematic literature review
32. Nikos Ath. Kallioras, Nikos D. Lagaros (2019) DL- Scale: Deep learning for model upgrading in topology optimization.
33. Nikos Ath. Kallioras, Nikos D. Lagaros (2021) MLGen: Generative Design Framework Based on Machine
34. Qiming Zhu, Zeliang Liu, Jinhui Yan (2021) Machine learning for metal additive manufacturing: predicting temperature andmelt pool fluid dynamics using physics-informed neural networks
35. Jichao Li and Mengqi Zhang (2020), Deep-Learning-Based Geometric Filtering Efficient Aerodynamic Shape Optimization with
36. Briggs/Kodnani (2018), The Potentially Large Effects of Artificial Intelligence on Economic Growth
37. John W. Ayers et al (2023) Comparing Physician and Artificial Intelligence Chatbot Responses to Patient Questions Posted to a Public Social Media Forum
38. <https://www.theguardian.com/technology/2023/apr/28/ai-has-better-bedside-manner-than-some-doctors-study-finds>

39. Karan Singhal et al (2023) Towards Expert-Level Medical Question Answering with Large Language Models
40. Behrooz Noori (2021) Classification of Customer Reviews Using Machine Learning Algorithms
41. **Meisam Babanezhad et al (2021)**, Performance and application analysis of ANFIS artificial intelligence for pressure prediction fo nanofluid convective flow in a heated pipe
42. <https://www.altalex.com/documents/news/2023/03/31/ia-chatgpt-bloccato-garante-privacy>
43. Tania Babina et al (2020) Artificial Intelligence, Firm Growth, and Industry Concentration
44. McKinsey global institute (2018), Notes from the AI frontier: Insight from hundreds of use cases
45. Norese, M.F., Ostanello, A. (1988), "Decision aid process typologies and operational tools"
46. Kwong C.K et al (2015), AI-based methodology of integrating affective design,engineering, and marketing for defining designs pecifications of newproducts
47. Zijiang Yang et al. (2018), Microstructural Materials Design via Deep Adversarial Learning Methodology
48. Ming Lu et al. (2007), Resource-constrained critical path analysis based on discrete event simulationand particle swarm optimization
49. Rajat Gera (2023), ARTIFICIAL INTELLIGENCE IN CONSUMER BEHAVIOUR: A SYSTEMATIC LITERATURE REVIEW OF EMPIRICAL RESEARCH PAPERS PUBLISHED IN MARKETING JOURNALS (2000-2021)
50. XinHu (2023), Explainable AI for customer segmentation in product development
51. Mintzberg (1976), The structure of unstructured decision processes

