



**Politecnico
di Torino**

POLITECNICO DI TORINO

Master's degree in
Energy and Nuclear Engineering

Course of Renewable Energy Systems

A.Y. 2022/23

**Game-Theoretic Approach for Multi-Criteria
Optimization of Community Energy Systems**

Advisor

Repetto Maurizio

Co-advisor

Lorenti Gianmarco

Candidate

De Chicchis Massimo

Abstract

The idea behind this thesis stems from the need to optimize the sizing of collective self-consumption systems and renewable energy communities. By considering the increasing importance of end consumers and their contribution to climate neutrality goals, these initiatives are emerging as promising solutions. However, due to their complexity and the presence of multiple conflicting objectives, it is necessary to develop suitable optimization approaches. In this context, the thesis proposes a Multi-Objective Optimization Problem based on Game Theory. Traditional Multi-Objective methods are inadequate for effectively managing the numerous objective functions involved (going from multi to many objectives), whereas the proposed method demonstrates greater capability in handling a higher number of objectives.

This approach goes beyond the simple simulation of different configurations to select the best one for the analyzed case, instead, considering the scenario as a game between various players, allows the direct identification of optimal solutions. Moreover, this optimization methodology can be applied not only to energy systems, but also to numerous other contexts.

In light of this, after a brief introduction to renewable energy communities and collective self-consumption, the proposed optimization methods are examined in detail. Different procedures have then been implemented in Python and tested on benchmark multi-objective problems. Afterwards, an optimization case study is performed on a collective self-consumption system using a dedicated simulation tool adapted to the specific context. Finally, the results obtained through the multi-objective optimization approach based on Game Theory are presented and also compared, when possible, with those derived from traditional optimization methods.

Contents

List of Tables	5
List of Figures	II
Introduction	1
1 Multi-Objective Optimization	4
1.1 Game Theory	7
1.1.1 Non-cooperative games, Nash equilibrium	11
1.1.1.1 Algorithm Implementation	11
1.1.1.2 Algorithms for constraints handling in non-cooperative Nash game	13
1.1.2 Cooperative games, bargaining solutions	15
1.1.2.1 Formulation of the Nash bargaining solution	16
1.1.2.2 Formulation of the Kalai-Smorodinsky bargaining solution	19
1.2 Game Theory - MOOP Algorithm	23
1.2.1 Game Theory - MOOP Test	23
1.2.1.1 Results for the benchmark functions	24
1.2.2 Choice of the single-objective minimization algorithm	32
2 Cscoupled	34
2.1 Components	37
2.2 Input data	38
2.3 Simulation of the energy node	39
2.4 Key Performance Indicators	39

3	Case Study	42
3.1	Case study input data	45
3.1.1	PV's production profiles	45
3.1.2	Thermal demand of the building	46
3.1.3	Electricity demand of the building	46
3.2	Energetic evaluation	47
3.3	Business model	47
3.3.1	Business Model's implementation	48
3.4	Simulation and Game Theory MOOP integration	50
4	Analysis of Results	52
4.1	Results of the Purely Electrical Case	52
4.2	Results of the Electrical and Thermal Case	57
4.3	Analysis without Non-Cooperative Nash Equilibrium	65
4.4	Discussion of the Results	69
5	Conclusions	72
	Bibliography	75

List of Tables

1.1	Definition of Ideal and Nadir points with two and three objective functions [6]	7
1.2	Variable values for the Binh and Korn function	26
1.3	Objective values for the Binh and Korn function	26
1.4	Variable values for the Viennet function	29
1.5	Objective values for the Viennet function	29
4.1	Values of the variables for the solutions of the Purely Electrical Case . .	54
4.2	Values of the objective functions for the solutions of the Purely Electrical Case	55
4.3	Values of the variables for the solutions of the Electrical and Thermal Case	59
4.4	Values of the objective functions for the solutions of the Electrical and Thermal Case	59
4.5	Results of the objective functions for the Electrical and Thermal Case by combining pcr_{cons} and pcr_{build}	61
4.6	Results of the objective functions for the Purely Electrical Case considering thermal expenses	62
4.7	Values of the variables for the solutions of the Electrical and Thermal Case considering global consumers	63
4.8	Values of the objective functions for the solutions of the Electrical and Thermal Case considering global consumers	64
4.9	Values of the design variables for the solutions of the Purely Electrical Case considering also the energetic KPIs	65

4.10	Values of the objective functions for the solutions of the Purely Electrical Case considering also the energetic KPIs	66
4.11	Values of the design variables for the solutions of the Electrical and Thermal Case considering also the energetic KPIs	68
4.12	Values of the objective functions for the solutions of the Electrical and Thermal Case considering also the energetic KPIs	68

List of Figures

1.1	Cooperative and non-cooperative game solutions [8]	9
1.2	Algorithm for determining non-cooperative Nash equilibrium.	14
1.3	Bargaining problem (adapted from [12])	17
1.4	Bargaining axioms (adapted from [12])	18
1.5	Nash’s bargaining solution (adapted from [12])	19
1.6	KS solution (adapted from [15])	20
1.7	Design Variable Space of the Binh and Korn Function	25
1.8	Objective Functions Space of the Binh and Korn Function	25
1.9	Design Variable Space of the Chankong and Haimes Function	27
1.10	Objective Functions Space of the Chankong and Haimes Function	27
1.11	Design Space for non-cooperative Nash	28
1.12	Design Variable Space of the Viennet Function	29
1.13	Objective Functions Space of the Viennet Function	30
1.14	Objective Functions Space of problem1	31
2.1	Schemes of a collective self-consumption (adapted from [27])	35
2.2	Schematic representation of an active energy node with multiple energy vectors (adapted from [28])	36
3.1	Share of residential building in Italy by construction period (adapted from [31])	42
3.2	Collective self-consumption in multifamily residential building [31]	43
3.3	Scheme of the energy flows in the collective self-consumption configuration (adapted from [31])	44

4.1	Variable space for solutions of the Purely Electrical Case	53
4.2	Objective function space for solutions of the Purely Electrical Case . . .	54
4.3	Investor's IRR trend as a function of pv_{size}	55
4.4	Objective function space for solutions of the Electrical and Thermal Case	58
4.5	Investor's IRR trend as a function of hp_{size}	60
4.6	Consumer's PCR trend as a function of hp_{size}	60
4.7	Objective function space for solutions of the Electrical and Thermal Case considering global consumers	63

Introduction

In recent decades, the need to address climate change and reduce dependence on traditional energy sources has led to the search for sustainable solutions in the energy sector. The European Union has positioned itself at the forefront of the fight against climate change. In fact, in December 2019, with the introduction of the Green Deal [1], it proposed a long-term strategy for a prosperous, modern, and competitive economy to achieve climate neutrality by 2050. This document emphasizes the importance of renewable energy sources and the central role of consumers, who are becoming increasingly active and crucial for the success of the energy transition.

In this context, collective self-consumption and renewable energy communities have emerged as promising and innovative solutions, revolutionizing the traditional approach to energy production, consumption, and management. These initiatives were first introduced at the European level with the Clean Energy for all Europeans Package (CEP) [2]. The CEP is a set of legislative acts that reshape the energy sector and introduce the tools for the creation of collective self-consumption and renewable energy communities through the Renewable Energy Directive 2018/2001 (RED II). This directive recognizes the active role of consumers in the energy transition and grants them the right to act collectively to produce, consume, sell, store, and share self-generated renewable energy. Italy has transposed this directive experimentally with the Decree-Law 162/2019 [3], which was converted into Law 8/2020. The Decree also establishes that the Regulatory Authority for Energy, Networks, and the Environment (ARERA) determines the economic settlement model for electricity shared within renewable energy communities, and the Ministry of Economic Development (MiSE) establishes the incentivizing tariffs and the related access modalities. The two documents were published on August 4, 2020, and September 15, 2020, respectively. The Decree-Law 162/2019 was subsequently

replaced by the Legislative Decree 199/2021. However, at present, the regulatory framework is not yet fully defined, and therefore, no official "second-generation" collective self-consumption and renewable energy communities have been established in practice. These entities represent a new paradigm in energy provision, based on a decentralized and participatory vision. Instead of relying solely on large centralized power plants, they involve a range of local actors, such as citizens, businesses, public institutions, and non-governmental organizations, who collaborate to maximize the use of renewable energy sources at the local level.

The main goal of these initiatives is to promote energy efficiency, environmental sustainability, and active citizen participation in the energy sector, while simultaneously reducing the reliance on traditional energy sources like coal and oil, and increasing the production and utilization of energy from renewable sources such as sunlight, wind, water, and biomass.

These decentralized production methods offer numerous advantages, in fact they: represent an economic saving for the participants, reducing the costs of energy bills; contribute to the reduction of energy poverty by enabling the participation of anyone, regardless of economic situation; ensure greater energy independence, reducing reliance on imported fossil fuels and stabilizing energy prices; promote local economic development, creating job opportunities and stimulating technological innovation in the renewable energy sector; contribute to the reduction of greenhouse gas emissions, helping to counteract climate change and improve the quality of the environment.

However, despite the numerous advantages of collective self-consumption and renewable energy communities, there are still significant challenges to address. One of the main challenges relates to the regulatory framework. It is crucial to establish an adequate legal and regulatory context to ensure the proper functioning and development of these new realities. This includes defining the rights and obligations of community members, access to electrical grids, measurement and compensation of produced and consumed energy, and fair remuneration for excess energy sold back to the grid.

Another equally important challenge is finding optimal configurations that make these entities more attractive and cost-effective. As they are relatively new and have multiple objectives to optimize simultaneously, there is still no methodology for sizing them

optimally. Hence, this thesis aims to analyze these entities using multi-objective optimization techniques to identify advantageous configurations from different perspectives. In this thesis work, a Python program called CSCoupled will be used to conduct simulations of collective self-consumption and renewable energy communities to determine the different objective functions to be optimised. Subsequently, a specific Python program for multi-objective optimization will be implemented. Since the objectives can be numerous and diverse, traditional optimization approaches have their limitations. Hence, an innovative approach based on Game Theory will be developed to address the challenge of handling a larger number of objectives in the optimization process. This methodology will allow to consider a wide range of perspectives and to obtain optimal solutions that effectively balance the desired objectives.

In light of the above, the thesis is organized as follows. In Chapter 1, the Multi-Objective Optimization is introduced with particular attention to the limitations of the traditional methodology. Subsequently, the Game Theory-MOOP is explained, distinguishing between non-cooperative and cooperative games, and illustrating the non-cooperative Nash solutions for the former and the Nash Bargaining solution and Kalai-Smorodinsky solution for the latter. These methods are then tested to evaluate their proper implementation on benchmark problems. In Chapter 2, the Python program used for simulating collective self-consumption is introduced, focusing on the structure of the tool, the required inputs, and the obtained results. In Chapter 3, the analyzed case study is presented, illustrating how the necessary data was obtained, describing the considered business models and outlining the different scenarios examined. Subsequently, in Chapter 4, the results of the Game Theory MOOP for the case study scenarios are analyzed, while in Chapter 5, the conclusions of this thesis work are drawn.

Chapter 1

Multi-Objective Optimization

Renewable Energy Communities and collective self-consumption thus represent a novel approach for sustainable transition through the utilization of renewable energy sources and enhancing energy provisioning. These communities, which can involve various renewable energy sources, storage systems, and consumers, aim to optimize their operations in an efficient and cost-effective way. This cannot be achieved solely through the optimization of a single objective, as Renewable Energy Communities and collective self-consumption face a range of conflicting and complex goals. Multi-objective optimization, therefore, becomes crucial for addressing the challenges associated with RECs. Multi-objective optimization is an area of multiple criteria decision making that is concerned with mathematical optimization problems involving more than one objective function to be optimized simultaneously [4]. This approach has been applied in various fields such as engineering, economics or logistics, where it is necessary to choose an optimal solution while considering conflicts among different objectives.

In most multi-objective optimizations, there is no single point that simultaneously optimizes the various objective functions, which may be conflicting. Thus, the Pareto Front is generated, which consists of all non-dominated, Pareto-optimal, or Pareto-efficient points. These points represent the optimal trade-offs among the objective functions, where improving the value of one objective function would inevitably result in the deterioration of the values of the others.

There are several methods for determining the Pareto front, which can be divided into two categories:

-
- *Solution-based methods*: These methods use one point at a time to determine the entire Pareto front. Among the most famous are the Weighted sum approach and the ϵ -constraints method.
 - *Population-based methods*: In contrast, these methods use a set of points to determine the Pareto front. The most commonly used methods include NSGA-II (Non-dominated Sorting Genetic Algorithm II), SPEA2 (Strength Pareto Evolutionary Algorithm 2), MOEA/D (Multiobjective Evolutionary Algorithm Based on Decomposition), and others.

When there are few objective functions to be simultaneously optimized, i.e., 2 or at most 3, these or other methods can be applied without any problems in most cases. However, as the number of objectives increases, the Pareto front also grows, and its determination and representation become increasingly complex. Furthermore, even if it were possible to represent the entire Pareto front, the decision maker would be left with a very large set of incomparable solutions, with limited practical relevance [5].

It is therefore necessary and advantageous to find alternative approaches of multi-objective optimization, without relying on the determination of the entire Pareto front, but still finding solutions belonging to it. One idea might be to use Game Theory.

Mathematical formulation of a multi-objective optimization problem

As previously mentioned, a multi-objective optimization problem is characterized by the need to simultaneously optimize multiple objective functions. Generally, these functions can be subject to constraints both on the functions themselves and on the variables that influence them. Keeping in mind that maximizing an objective function is equivalent to minimizing its negative and vice versa, the optimization problem can be expressed in mathematical form as follows:

$$\min_{x \in X} (f_1(x), f_2(x), \dots, f_k(x)) \quad (1.0.1)$$

subject to:

$$g_j(X) \leq 0, \quad j = 1, \dots, m \quad (1.0.2)$$

and

$$x_i^{\min} \leq x_i \leq x_i^{\max}, \quad i = 1, \dots, n \quad (1.0.3)$$

where the integer $k \geq 2$ is the number of objectives and the set X is the feasible set of decision vectors, which depends on the n -dimensional application domain.

As regards the Pareto front, in mathematical terms, a feasible solution $x_1 \in X$ is said to dominate another solution $x_2 \in X$ if:

1. $\forall i \in 1, \dots, k, \quad f_i(x_1) \leq f_i(x_2)$, and
2. $\exists i \in 1, \dots, k, \quad f_i(x_1) < f_i(x_2)$.

The Pareto front of a multi-objective optimization problem is bounded by a so-called nadir objective vector, denoted as z_{nadir} , and an ideal objective vector, denoted as z_{ideal} , provided that they are finite [4]. The nadir objective vector is defined as:

$$z_{nadir} = \begin{pmatrix} \sup_{x^* \in X^*} f_1(x^*) \\ \cdot \\ \cdot \\ \cdot \\ \sup_{x^* \in X^*} f_k(x^*) \end{pmatrix} \quad (1.0.4)$$

and the ideal objective vector as:

$$z_{ideal} = \begin{pmatrix} \inf_{x^* \in X^*} f_1(x^*) \\ \cdot \\ \cdot \\ \cdot \\ \inf_{x^* \in X^*} f_k(x^*) \end{pmatrix} \quad (1.0.5)$$

In other words, the components of the nadir and ideal point vectors represent the upper and lower bounds of the Pareto front. However, it should be noted that in practice, the nadir vector is almost always approximated since it would be necessary to know the entire Pareto Front to determine it. Therefore, instead of the nadir vector, a pseudo-nadir point, $z_{pseudo-nadir}$, is commonly used.

For the determination of these points, inspiration was taken from the approach proposed by Iorio et al. [6], as shown in the following table:

Table 1.1: Definition of Ideal and Nadir points with two and three objective functions [6]

$x_1^* = \min_x f_1(x)$	→ Unconstrained minimization of $f_1(x)$
$x_2^* = \min_x f_2(x)$	→ Unconstrained minimization of $f_2(x)$
$x_3^* = \min_x f_3(x)$	→ Unconstrained minimization of $f_3(x)$
$z_{ideal} = [f_1(x_1^*), f_2(x_2^*)]$	→ Ideal point in 2D problems
$z_{nadir} = [f_1(x_2^*), f_2(x_1^*)]$	→ Nadir point in 2D problems
$z_{ideal} = [f_1(x_1^*), f_2(x_2^*), f_3(x_3^*)]$	→ Ideal point in 3D problems
$z_{pseudonadir} = [max(f_1(x_2^*), f_1(x_3^*)),$ $max(f_2(x_1^*), f_2(x_3^*)), max(f_3(x_1^*), f_3(x_2^*))]$	→ Pseudonadir point in 3D problems

For problems with dimensions greater than 3, the Utopia and Nadir points were found using the same methodology as for the 3-dimensional problem.

Furthermore, instead of the ideal vector, the utopian objective vector z_{utopia} is often used, where $z_{utopia}^i = z_{ideal}^i - \epsilon$, $\forall i \in 1, \dots, k$ and $\epsilon > 0$ is a small constant. However, in the subsequent discussion, it will not be necessary, and therefore the terms "ideal" and "utopia" will be used interchangeably.

1.1 Game Theory

In simple terms, Game Theory models situations where players make decisions to maximize their own utility, taking into account that other players are doing the same and that the decisions made by players have an impact on each other's utilities [7]. Game Theory is generally divided into two categories: non-cooperative and cooperative.

Non-cooperative Game Theory studies game strategies, analyzing the different decisions of players and carefully examining the various steps to reach a solution. On the other hand, cooperative Game Theory analyzes all possible solutions to see which ones can be achieved, it may study the coalitions that can be formed, and it can determine whether the reached solution is stable and robust. Therefore, it can be stated that cooperative Game Theory analyzes the game as a "black box", while non-cooperative Game Theory precisely analyzes what happens [7].

It is thus possible to view a multi-objective problem, typically described as in Section 1, through a Game Theory-based approach. Let us then explore the non-cooperative and cooperative approaches based on the work of Annamdas et al. [8].

For simplicity, let's assume that the number of objective functions, k , is equal to the

number of design variables, n . This doesn't have to be true, but it makes the explanation easier. We now associate a player with each objective function, and for simplicity, let's assume that each player has control over only one design variable. It is important to specify that even though player i has control only over variable x_i , the actions of other players can still influence his objective function since it also depends on the design variables of other players. This, in fact, can be expressed as: $f_i(x_1, x_2, \dots, x_{(i-1)}, x_i, x_{(i+1)}, \dots, x_n)$. Therefore, the goal of the i -th player is to optimize (in the example we will consider, minimize) their objective function f_i while taking into account the actions of the other players who also want to minimize their own objective functions. This game can be visualized more clearly, graphically, by considering only two players who have control over as many variables, as described in [8]. Thus, it can be written:

$$Player_1 : \min_{x_1} f_1(x_1, x_2) \quad (1.1.1)$$

and

$$Player_2 : \min_{x_2} f_2(x_1, x_2) \quad (1.1.2)$$

Where $Player_1$ aims to minimize the objective function f_1 by controlling only variable x_1 , but its objective function can be influenced by the variable controlled by $Player_2$, x_2 , and vice versa.

Assuming these functions are continuous, it is possible to represent them with contours of constant values in a graph of the design variables, as shown in the Figure 1.1:

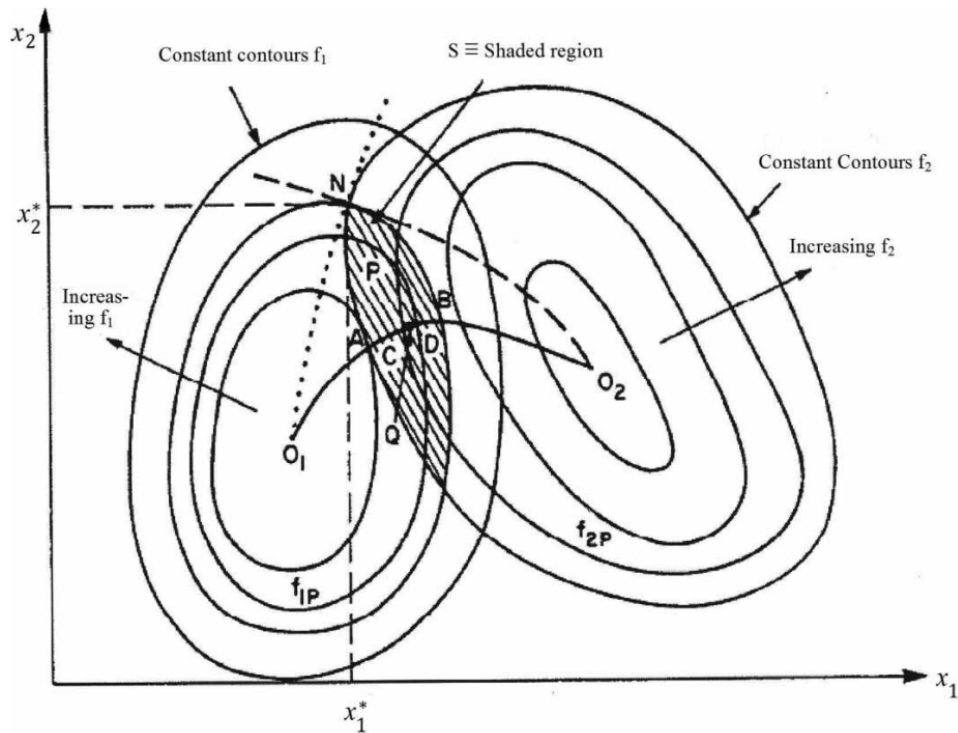

Figure 1.1: Cooperative and non-cooperative game solutions [8]

The dashed lines in the figure, starting from the global minimum points O_1 and O_2 , represent the minimum values of the functions f_1 and f_2 for every value of variable x_2 and x_1 respectively. Therefore, their intersection, if it exists, is an excellent candidate for the equilibrium point in a non-cooperative game. This point, referred to as $N(x_1^*, x_2^*)$ in Figure 1.1, is the Nash equilibrium point and represents a condition of stable equilibrium in the sense that no player can unilaterally deviate from it to further improve his own objective function [8]. This point therefore has the following characteristics:

$$f_1(x_1^*, x_2^*) \leq f_1(x_1, x_2^*) \quad (1.1.3)$$

and

$$f_2(x_1^*, x_2^*) \leq f_2(x_1^*, x_2) \quad (1.1.4)$$

where x_1 is any x to the right or left of point N at a constant x_2 , and at the same time, x_2 is any x higher or lower than point N at a constant x_1 . It is possible to generalize

these conditions for k objective functions and k design variables as follows:

$$\begin{aligned}
 f_1(x_1^*, x_2^*, \dots, x_k^*) &\leq f_1(x_1, x_2, \dots, x_k) \\
 f_2(x_1^*, x_2^*, \dots, x_k^*) &\leq f_2(x_1, x_2, \dots, x_k) \\
 &\cdot \\
 &\cdot \\
 &\cdot \\
 f_k(x_1^*, x_2^*, \dots, x_k^*) &\leq f_k(x_1, x_2, \dots, x_k)
 \end{aligned}
 \tag{1.1.5}$$

An interesting situation arises when the dashed lines intersect at multiple points. In this case, one should also consider the order in which each player makes their moves but, since it is not relevant for our analysis, this situation will not be considered.

However, it is possible to observe that every point in the shaded area of Figure 1.1 is a better solution for this game, but it cannot be achieved non-cooperatively. These solutions become accessible only by considering a cooperative game.

In a cooperative game, in fact, the two players cooperate with each other to achieve a better solution for both of their objectives. Hence, as mentioned earlier, it is possible to reach a solution in the shaded area in the figure above, and in fact, it is even possible to achieve a Pareto solution, represented by the curved line $O_1ACQDBO_2$. Therefore, the optimal solutions are those on the line AB (i.e., the intersection between the shaded area in Figure 1.1 and the Pareto set $O_1ACQDBO_2$). It is now possible to find a solution on this line that represents a compromise between the objectives of the different players. In order to do so, players establish specific negotiation rules that can be used to formulate a super-criterion or a bargaining model [8]. This super-criterion is then used to transform the multi-objective optimization into an equivalent single-objective optimization and achieve a compromise point between the different players that lies on the Pareto front. However, it should be noted that even in a non-cooperative game, it is possible to obtain Pareto solutions, but this is never certain, as expressed more clearly in the formulation of Tang et al. [9], whereas it is only certain with a cooperative game.

1.1.1 Non-cooperative games, Nash equilibrium

The Nash strategy is, as mentioned before, a non-cooperative game. In this, players make their decisions independently and simultaneously, without knowing in advance the choices of other players. Additionally, each player only cares about their instantaneous payoff and does not take into account the effect their choices have on other players [9]. The point reached, which is the Nash equilibrium defined earlier by equation 1.1.5, can also be defined, as reported by Binois et al. [5], through the following definition: A Nash equilibrium $x^* \in X$ is a strategy such that:

$$(NE) \quad \forall i, \quad 1 \leq i \leq m, \quad \mathbf{x}_i^* = \arg \min_{\mathbf{x}_i \in \mathbf{X}_i} f_i(\mathbf{x}_i, \mathbf{x}_{-i}^*) \quad (1.1.6)$$

This formulation shows in a simpler way the advantages of this non-cooperative strategy: it is scale-invariant and conveys a notion of first-order stationarity. However, as already implied, it requires a number of design variables greater than or equal to the number of objective functions and necessitates a partitioning of the design variables among the different players. This last point may be trivial in some games (considering, for example, games where the objective functions are physical equations), but in many other games, it can be problematic. A solution, as proposed by Binois et al. [5], could be to perform this partitioning through a sensitivity analysis.

The Nash equilibrium point, therefore, depends on how the variable partitioning is decided, as well as on the starting point of the algorithm.

1.1.1.1 Algorithm Implementation

Let's take the articles by Tang et al. [9], [10] as a reference for explaining the algorithm. Firstly, it is necessary to allocate the design variables to the different players (a player can control more than one design variable, as long as he controls at least one). Then, as mentioned earlier, each player tries to optimize his objective function by modifying his design variables while keeping the others constant and exchanging symmetric information with the other players at regular intervals.

To simplify the explanation, let's consider an example with just 2 players, similar to the one proposed in Chapter 1.1. Therefore, each player aims to minimize its respective objective function by modifying only its own design variable, as expressed by equations

1.1.1 and 1.1.2, which are written again here for convenience:

$$\begin{aligned} \text{Player}_1 &: \min_{x_1} f_1(x_1, x_2) \\ \text{Player}_2 &: \min_{x_2} f_2(x_1, x_2) \end{aligned}$$

where in each iteration, in the first of the two equations, x_1 is the free design variable for Player_1 while x_2 is kept fixed and derives from the previous action of Player_2 . Similarly, in the second equation x_2 is the free design variable for Player_2 while x_1 is kept fixed and derives from the previous action of Player_1 . In particular, we assume that:

$$\mathbf{x}^{m-1} = (x_1^{m-1}, x_2^{m-1}) \quad (1.1.7)$$

are the design variables that minimize the objective functions of Player_1 and Player_2 , respectively, at iteration $m - 1$. In the next iteration m , Player_1 minimizes its objective function f_1 by varying x_1 starting from x_1^{m-1} while keeping x_2 constant and equal to x_2^{m-1} . Player_2 behaves symmetrically in the same manner. So at iteration m we get:

$$x_1^m = \inf_{x_1} f_1(x_1, x_2^{m-1}) \quad (1.1.8)$$

and

$$x_2^m = \inf_{x_2} f_2(x_1^{m-1}, x_2) \quad (1.1.9)$$

Having calculated the new design variables that minimize the two objective functions, Player_1 communicates its x_1^m to Player_2 for the calculation of the next iteration $m + 1$, and vice versa. This process ends when each player can no longer further improve its objective function, that is, when convergence of the objective functions is reached. This occurs at iteration j where:

$$f_i^{j-1} = f_i^j \quad (1.1.10)$$

or for simplicity of calculation:

$$|f_i^j - f_i^{j-1}| \leq t_{\text{resh}} \quad (1.1.11)$$

where t_{resh} is defined at the beginning.

The point thus found:

$$\mathbf{f}^j = [f_1(x_1^j, x_2^j), f_2(x_1^j, x_2^j)] \quad (1.1.12)$$

is the Nash equilibrium point.

However, it is important to note that this point is not unique. In fact, it can vary significantly depending on the partitioning of the design variables and on the starting point for the algorithm just described. In the first iteration, it is necessary in fact to provide an initial point:

$$\mathbf{x}^0 = (x_1^0, x_2^0) \quad (1.1.13)$$

in order to start the process.

A schematic representation of the algorithm is shown in Figure 1.2.

1.1.1.2 Algorithms for constraints handling in non-cooperative Nash game

A problem may arise when implementing constraints on the objective functions. For example, consider the following game:

$$Player_1 = \begin{cases} \min_{x_1} f_1(x_1, x_2) \\ \text{Subject to } g_1(x_1, x_2) = g'_1 \end{cases} \quad (1.1.14)$$

and

$$Player_2 = \begin{cases} \min_{x_2} f_2(x_1, x_2) \\ \text{Subject to } g_2(x_1, x_2) = g'_2 \end{cases} \quad (1.1.15)$$

the constraints are satisfied in the minimization of the objective functions for both players, but when exchanging information, it is not guaranteed that they will still be satisfied. Suppose, for instance, that at iteration $(m - 1)$, the solution for the design variables is: $\mathbf{x}^{(m-1)} = (x_1^{(m-1)}, x_2^{(m-1)})$. In light of the aforementioned, the following equations will be satisfied:

$$g_1(x_1^m, x_2^{(m-1)}) = g'_1 \quad \text{and} \quad g_2(x_1^{(m-1)}, x_2^m) = g'_2 \quad (1.1.16)$$

However, when the players symmetrically exchange information to form $\mathbf{x}^m = (x_1^m, x_2^m)$, it could be that:

$$g_1(x_1^m, x_2^m) \neq g'_1 \quad \text{and} \quad g_2(x_1^m, x_2^m) \neq g'_2 \quad (1.1.17)$$

One way to solve this problem is presented by Tang et al. [11], in which they develop a cooperative game between a player who in turn plays a non-cooperative Nash game for optimizing the two unconstrained objective functions, and another player who handles the original constraints. However, to find the solution for this game, Tang et al. rely on

the gradients of the functions, which cannot always be computed, as will be the case in the specific study we will analyze.

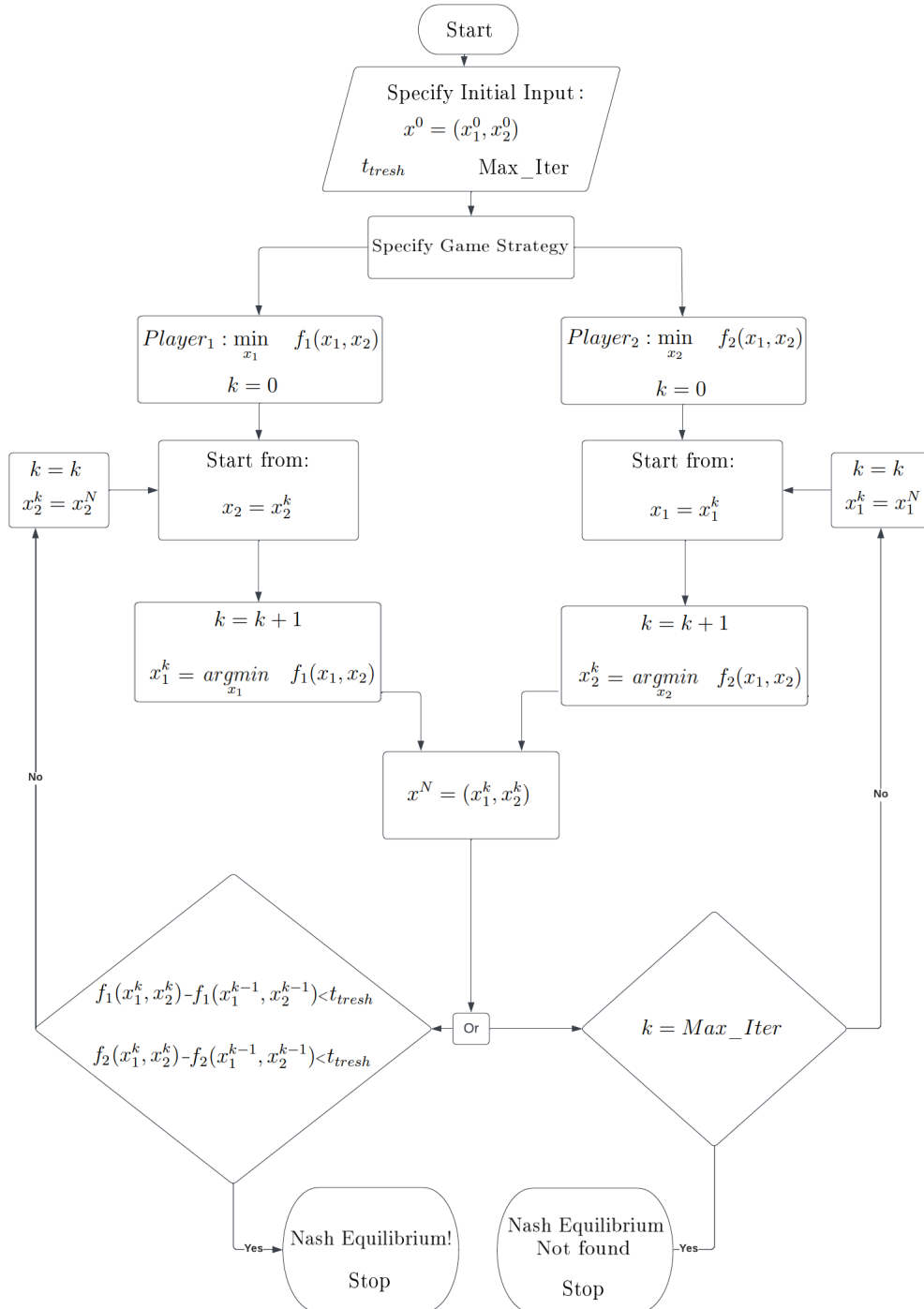

Figure 1.2: Algorithm for determining non-cooperative Nash equilibrium.

1.1.2 Cooperative games, bargaining solutions

The bargaining model introduces a concept of solution for cooperative games where negotiation processes or group decisions are involved. Cooperation refers to coalitions of two or more players acting together with a specific common purpose, while considering the objective of maximizing their own individual payoffs [12]. A cooperative game is, in other words, a game in which players have the opportunity to reach, through an agreement between parties, a better solution than the one that could be achieved without the agreement. With a bargaining model, it is possible to reach a mutually advantageous agreement, or if this is not possible, the solution of "no agreement" is imposed, which is disadvantageous or less advantageous for all players involved. There are two theoretical perspectives that provide a solution for cooperative bargaining models based on game theory and that employ the axiomatic method to evaluate bargaining: Nash bargaining model and Kalai-Smorodinsky model [12].

In the following, the main differences between the Nash bargaining solution and the Kalai-Smorodinsky solution are explained based on the findings of Trejo et al. [12]. Both methods aim to achieve a "fair" solution to the cooperative game, but they differ in their definition of fairness.

According to Nash's proposal [13], a solution to a bargaining problem is a function that takes the characteristics of the bargaining problem as input and returns a vector of solutions for each player that belongs to the set of possible solutions. This function must be valid for any bargaining problem. It can return various values, such as the disagreement point itself or a solution that only optimizes one player's objective function, disregarding the others'. Although both of these solutions are correct and comply with what was previously stated, they have inconsistencies regarding fairness. While the second solution is "unbalanced" in favor of a single player and thus not promising for the others, the first one is non-Pareto efficient and therefore does not fully utilize the potential of cooperation between players. To resolve these inconsistencies, Nash proposed four axioms that the solution of the bargaining problem must satisfy. According to Nash, the solution should be:

- (a) *Invariant to affine transformation*: an affine transformation of the possible solu-

- tions and of the disagreement point should not alter the outcome of the bargaining;
- (b) *Pareto optimality*: the solution must be Pareto optimal, meaning it must lay on the Pareto frontier;
 - (c) *Simmetry*: if the players are indistinguishable, the solution should not discriminate against one player or the other;
 - (d) *Independence of irrelevant alternatives*: if a solution is chosen from a feasible set that is a subset of the original set but contains the solution's previously selected point, then the solution must still assign the same point chosen from the subset. In other words, the addition of a third, irrelevant, alternative does not have an influence on the choice between the first alternatives.

Following these principles, Nash proposed the following solution to the bargaining problem: *we say that there is a unique solution β to the bargaining problem that satisfies the four axioms (a to d) which is given by the point that maximizes the product of utilities of the players* [13].

While the first three axioms were accepted without issues, the fourth axiom has attracted some criticism. Based on this, Kalai and Smorodinsky [14] developed subsequent work, formulating a solution to the bargaining problem, that replaces the fourth axiom (d) with a monotonicity axiom:

- (e) *Monotonicity*: if the set of possible solutions is expanded in a way that the best solutions remain unchanged, then no player should be disadvantaged by it.

Considering this fifth axiom (e) instead of the debatable fourth one (d), Kalai and Smordinsky proposed the following solution: *we say that there is a unique solution β to the bargaining problem that satisfies the four axioms (a,b,c and e) which is given by the intersection point of the Pareto frontier and the straight line segment connecting the disagreement and the utopia point* [14].

1.1.2.1 Formulation of the Nash bargaining solution

In this paragraph, we will formulate the Nash bargaining solution, taking inspiration from what was proposed by Trejo et al. [12].

For simplicity, let's consider only two players, *Player₁* and *Player₂*. The bargaining

problem is defined as the pair $\mathcal{B} = (\Theta, d)$ in the space of objective functions, where Θ is a set of possible agreements of the objective functions f for $Player_1$ and $Player_2$. These functions are strictly increasing and concave. Θ is a compact and convex set in \mathbb{R}^2 . An element of Θ is a pair $f = (f_1, f_2) \in \Theta$, while the disagreement point is $d = (d_1, d_2)$. The set Θ consists of points that dominate the disagreement point d . The solution to a bargaining problem, as mentioned earlier, is a function F that takes any bargaining problem as input and returns a pair of objective functions: $f = (f_1, f_2) \in \Theta$, where $f_1 = F_1(\mathcal{B})$ and $f_2 = F_2(\mathcal{B})$. Therefore, the interpretation of a cooperative bargaining game is that given a $\mathcal{B} = (\Theta, d)$, there exists an agreement $f = F(\Theta, d) \in \Theta$ composed of objective function values that dominate the disagreement point and ensure a mutually advantageous agreement. Figure 1.3 shows this bargaining problem:

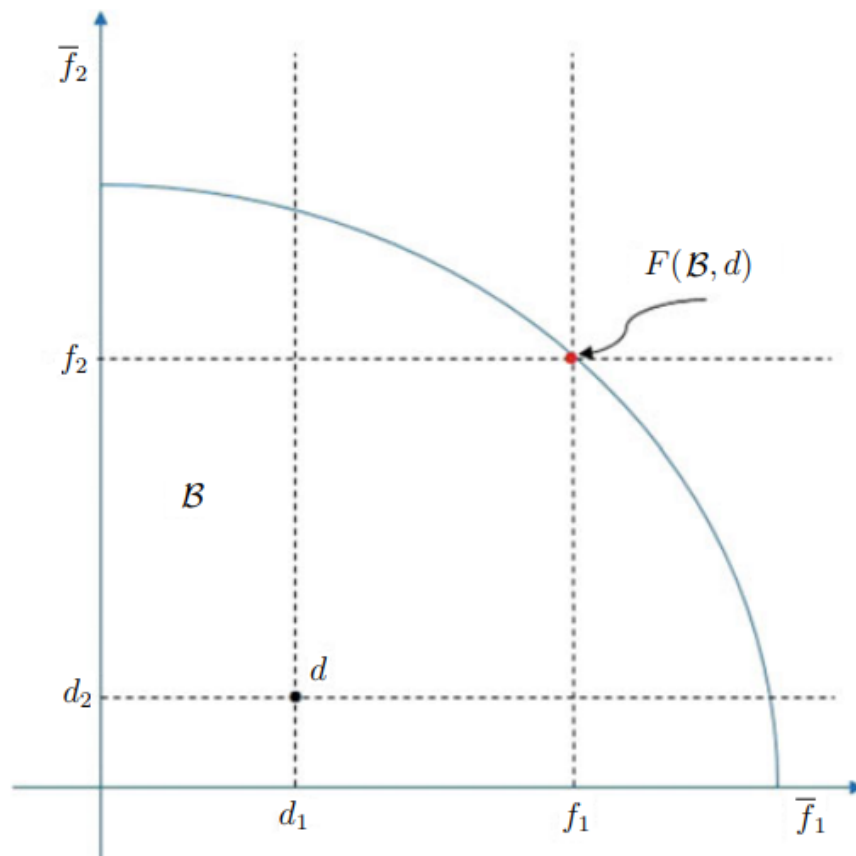

Figure 1.3: Bargaining problem (adapted from [12])

The two most important and most restrictive axioms are:

- *Pareto optimality*: This means that there is no point $f = (f_1, f_2) \in \Theta$ that dominates the components of the solution to the bargaining problem such that $(f_1, f_2) \neq F(\Theta, d)$.
- *Symmetry*: Assuming a \mathcal{B} such that \bar{f} (the set of all f) is symmetric around the 45-degree line and $d_1 = d_2$, it must necessarily hold that $F_1(\mathcal{B}) = F_2(\mathcal{B})$.

The representation of the bargaining problem with these restrictions is shown in figure 1.4:

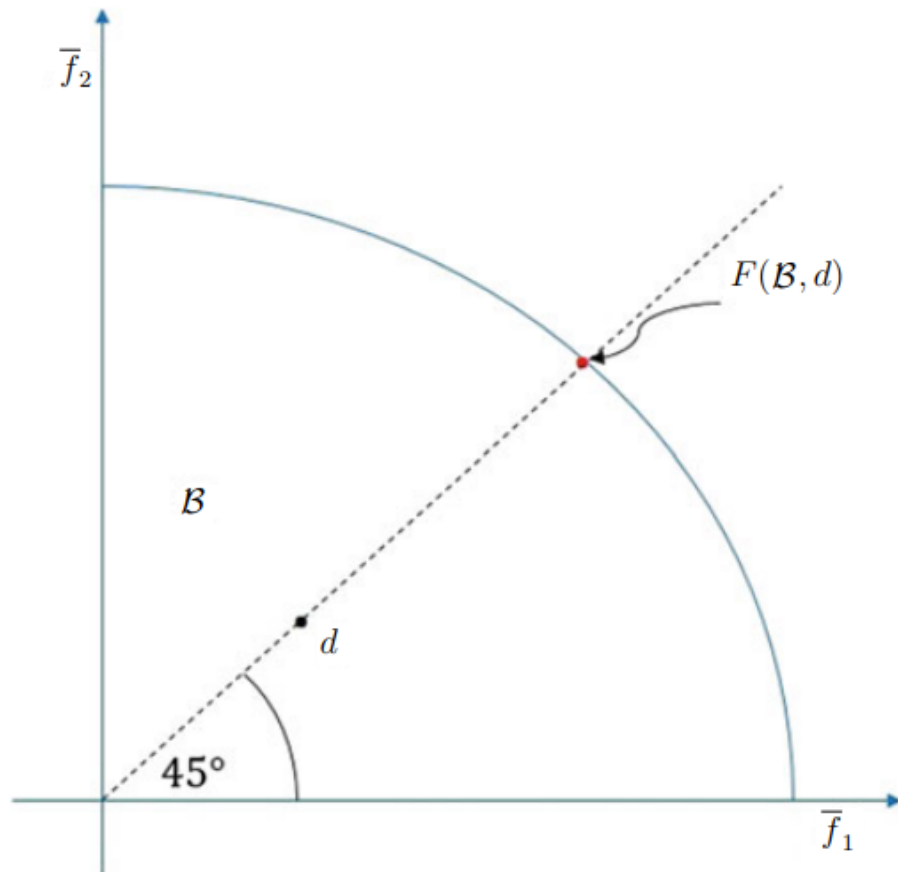

Figure 1.4: Bargaining axioms (adapted from [12])

The Nash bargaining solution of the presented problem is, therefore, the pair of

objective function solutions $(f_1, f_2) \in \Theta$ that solves the following maximization problem:

$$\max_{f_1, f_2 \in \Theta} (f_1 - d_1) \cdot (f_2 - d_2) \quad (1.1.18)$$

where $\Theta \equiv (f_1, f_2) \in \Theta | f_1 \geq d_1$ and $f_2 \geq d_2$. This solution is unique since the product $(f_1 - d_1) \cdot (f_2 - d_2)$ (referred to as the Nash product) is continuous and concave. Figure 1.5 illustrates the Nash bargaining solution:

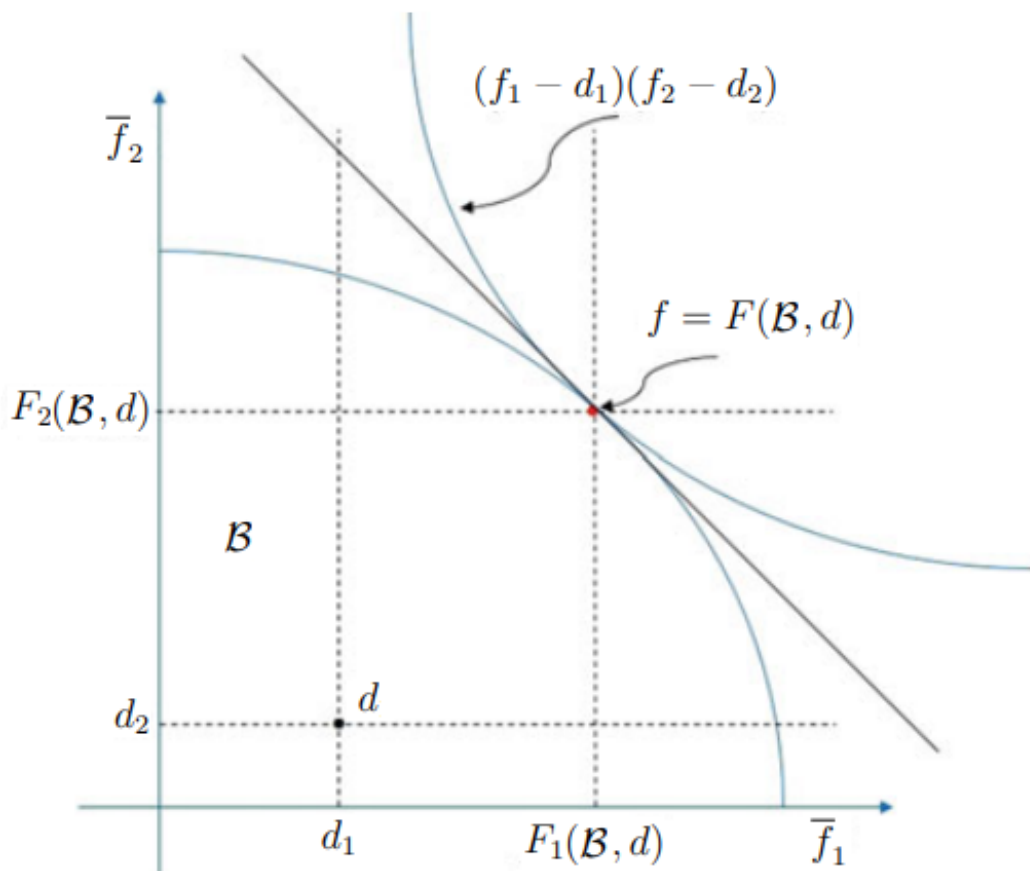

Figure 1.5: Nash's bargaining solution (adapted from [12])

1.1.2.2 Formulation of the Kalai-Smorodinsky bargaining solution

As mentioned before, the Kalai-Smorodinsky solution differs from Nash's solution by replacing the axiom of independence of irrelevant alternatives with the monotonicity axiom. The idea of the solution to this problem can be graphically represented

by connecting the disagreement point d with the utopia point u , which represents the optimal values, although unattainable, for the players' objective functions. The Kalai-Smorodinsky solution is the feasible point lying on this line that is closest to the utopia point, specifically the intersection point between this line and the Pareto front.

In other words, the players aim to optimize their objective functions starting from the disagreement point d and moving towards the Pareto front. The KS solution is of egalitarian inspiration and states that the chosen efficient solution should result in an equal ratio of benefits for all players [15]. This is defined as follows:

$$r^i(s) = \frac{d^i - s^i}{d^i - u^i} \quad (1.1.19)$$

where d and u are respectively the disagreement and utopia points, and s is any compromise solution $s = [f^1(x), \dots, f^k(x)]$. It should be noted that the benefit ratio is zero at the disagreement point and reaches its maximum value at the utopia point. Therefore, the KS solution is computed by maximizing the benefit ratios for the different players while keeping them equal. It can be easily demonstrated that this solution is the point of intersection between the Pareto front and the line connecting (d, u) . Figure 1.6 illustrates the KS solution for two players:

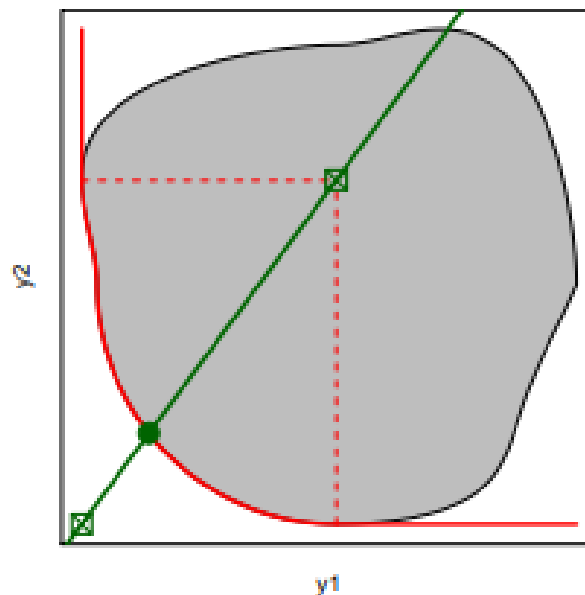

Figure 1.6: KS solution (adapted from [15])

This methodology can pose problems in the case of a discontinuous front or, more generally, when there is no intersection between the line (d, u) and the Pareto front, which can also occur with three or more players. To address these issues, we employ the methodology described by Iorio et al. [6].

Once again, for simplicity, let's consider a game with only two objective functions, f_1 and f_2 . The algorithm proposed begins by identifying the utopia point z_{utopia} and the nadir point z_{nadir} for the objective functions under consideration. Subsequently, a functional formulation is proposed to be minimized in order to quickly find a solution that is very close to the Kalai-Smorodinsky point:

$$\begin{aligned} & \min_{x,t} t \\ \text{Subject to } & \begin{cases} z_{utopia} + t \cdot \tau = F(x) \\ x_i^{min} \leq x_i \leq x_i^{max}; \quad i = 1, \dots, n \end{cases} \end{aligned} \quad (1.1.20)$$

where $\tau = \frac{z_{nadir} - z_{utopia}}{\|z_{nadir} - z_{utopia}\|}$. Therefore the function to be minimized in the optimization problem is:

$$F(x) = z_{utopia} + t \cdot \tau \quad (1.1.21)$$

which minimizes $F(x)$ by moving towards the utopia point while staying on the line connecting the utopia and nadir points. To be properly used in an engineering context, it is necessary to slightly modify this formulation by normalizing each "variable" with respect to the utopia and nadir points. Specifically:

$$f_1'(x) = \frac{f_1(x)}{f_1(x_2^*) - f_1(x_1^*)} \quad (1.1.22)$$

$$f_2'(x) = \frac{f_2(x)}{f_2(x_1^*) - f_2(x_2^*)} \quad (1.1.23)$$

$$\tau_1' = \frac{f_1'(x_2^*) - f_1'(x_1^*)}{\sqrt{(f_1'(x_2^*) - f_1'(x_1^*))^2 + (f_2'(x_1^*) - f_2'(x_2^*))^2}} \quad (1.1.24)$$

$$\tau_2' = \frac{f_2'(x_1^*) - f_2'(x_2^*)}{\sqrt{(f_1'(x_2^*) - f_1'(x_1^*))^2 + (f_2'(x_1^*) - f_2'(x_2^*))^2}} \quad (1.1.25)$$

It is therefore possible to rewrite the equation 1.1.21 as follows:

$$\begin{bmatrix} f_1'(x) \\ f_2'(x) \end{bmatrix} = \begin{bmatrix} f_1'(x_1^*) \\ f_2'(x_2^*) \end{bmatrix} + t \cdot \begin{bmatrix} \tau_1' \\ \tau_2' \end{bmatrix} \quad (1.1.26)$$

and eliminating the auxiliary variable "t" we obtain the following:

$$t = \frac{f'_1(x) - f'_1(x_1^*)}{\tau'_1} = \frac{f'_2(x) - f'_2(x_2^*)}{\tau'_2} \quad (1.1.27)$$

these equation must be satisfied in order to find the solution KS. These two terms can be associated with two functions:

$$g_1(x) = \frac{f'_1(x) - f'_1(x_1^*)}{\tau'_1} \quad (1.1.28)$$

and

$$g_2(x) = \frac{f'_2(x) - f'_2(x_2^*)}{\tau'_2} \quad (1.1.29)$$

i.e. it must be:

$$g_1(x) = g_2(x) \quad (1.1.30)$$

Finally, the functions 1.1.28 and 1.1.29 must be combined with the function 1.1.30 using a penalty coefficient ρ , resulting in the following function:

$$g_p(x) = g_1(x) + g_2(x) + \rho|g_1(x) - g_2(x)| \quad (1.1.31)$$

By minimizing this function, it is possible to obtain an approximation of the KS solution. As proposed in the cited article [6], in this discussion, a ρ equal to one has been imposed. However, it is important to note that while in a game with only two players the solution is unique and satisfies all the axioms defined in section 1.1.2, in the case of three or more players, only some of them are satisfied: Pareto optimality, affine invariance, and equity in benefit ratio [15].

Therefore, both the Kalai-Smorodinsky and the Nash Bargaining solutions are particularly interesting for games with many players because they easily adapt to multiple objectives and provide a unique solution without the need to approximate the extensive Pareto front.

As defined, it is evident that these solutions heavily depend on the chosen disagreement point. A common choice for this point is the Nadir one, but different authors also consider the Nash equilibrium point derived from non-cooperative game theory. In this discussion, both will be considered as disagreement points. The first one is chosen due to its widespread use in the literature, while the second one, being an equilibrium point

found without cooperation among players, can be considered as a point of disagreement in cooperative games. That is, if the players fail to reach an agreement in the cooperative game, they may resort to playing non-cooperatively and converge to the Nash equilibrium.

1.2 Game Theory - MOOP Algorithm

The algorithm for conducting multi-objective optimization using Game Theory has been implemented in Python. This algorithm takes as input a set of functions that need to be optimized simultaneously, whether they are arithmetic functions or simulations of entities conducted through external software. For instance, in this thesis, collective self-consumption simulations will be utilized. It is also necessary to provide the constraints of the design variables within the functions, as well as, if required, the limits of the functions themselves and also the distribution of design variables among different players for the calculation of the non-cooperative Nash equilibrium point. With this data, the algorithm performs multi-objective optimization and typically returns seven points: the Utopia point, the Nadir point, the non-cooperative Nash equilibrium point, and four additional solutions, namely the Nash Bargaining and Kalai-Smorodinsky equilibrium points that consider the Nadir or the non-cooperative Nash equilibrium as the disagreement points. The first three points do not represent the optimization solutions but serve as starting points for determining the Nash Bargaining and Kalai-Smorodinsky equilibria, which, in turn, represent the actual solutions of the algorithm.

It is important to bear in mind that in cases where there are constraints on the objective functions or when the number of objective functions exceeds the number of design variables, the calculation of the non-cooperative Nash equilibrium point is not possible. As a result, the actual solutions are reduced to two: the Nash Bargaining equilibrium and the Kalai-Smorodinsky equilibrium, both starting from the Nadir.

1.2.1 Game Theory - MOOP Test

After implementing the optimization algorithms described above in Python, it was decided to conduct tests to verify the proper functioning of the script. To do this,

considering that the points found should lay on the Pareto Front, tests were carried out using benchmark functions for its determination. Therefore, it was essential to first implement an algorithm to determine the Pareto Front. Among the various available options, some of which were previously mentioned in Chapter 1, the decision was made to utilize NSGA2, specifically the implementation provided by pymoo [16]. The benchmark functions used for the tests are instead some of those presented in [17], specifically the Binh and Korn function, the Chankong and Haimes function, and the Viennet function. The first two functions are the simplest, featuring only two objective functions and two design variables, but they were beneficial during the initial phase of the experiments. They were implemented without constraints for convenience. The Viennet function, on the other hand, is more complex, featuring three objective functions, and it was used to verify the algorithm's generalization to higher dimensions. However, this function only has two design variables, which prevents the determination of non-cooperative Nash. As a result, further tests were conducted on custom-created problems with three objective functions and three design variables. In particular one of the analyzed problem is the following one:

$$\text{Minimize} = \begin{cases} f_1 = (x_0 - 1)^2 + x_1^2 + x_2 \\ f_2 = (x_0 + 1)^2 + 2 \cdot x_1 + x_2^2 \\ f_3 = -x_0 + x_1^2 + (x_2 - 1)^2 \end{cases} \quad (1.2.1)$$

where all variables are bounded between -5 and 5.

1.2.1.1 Results for the benchmark functions

This section presents the results of the multi-objective optimization using Game Theory for the different benchmark functions. In particular, for the Binh and Korn function the obtained values of variables and objective functions are reported respectively in Figures 1.7 and 1.8:

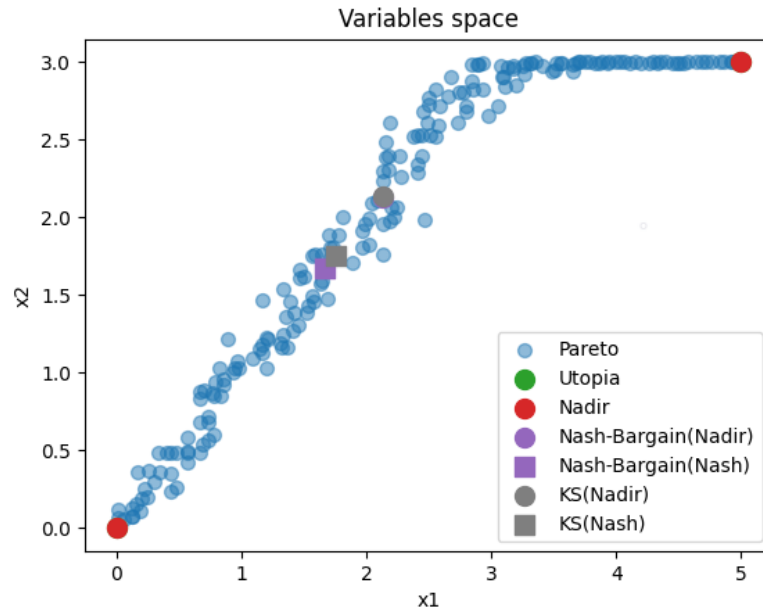

Figure 1.7: Design Variable Space of the Binh and Korn Function

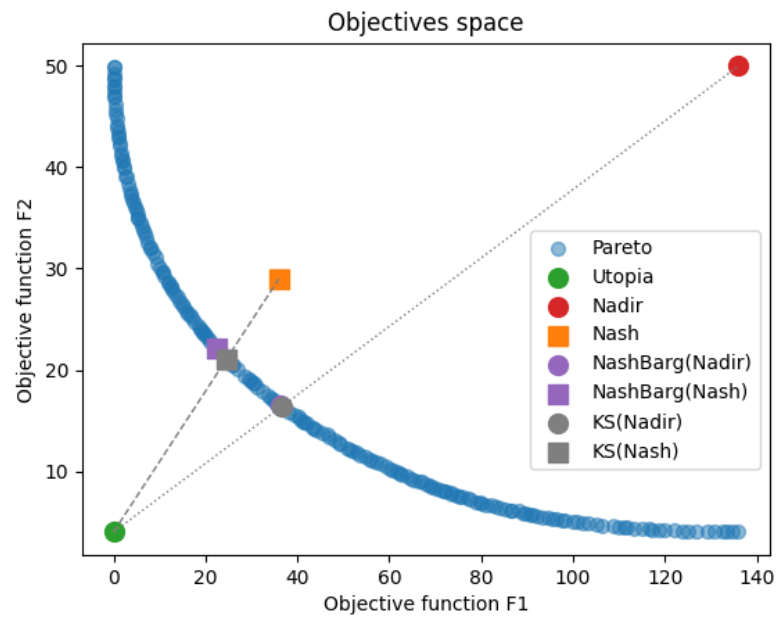

Figure 1.8: Objective Functions Space of the Binh and Korn Function

From the design variables graph, it is evident that there are two points for both the Utopia and the Nadir. It is important to note that the points are the same, but those

of the Nadir overlap with those of the Utopia. These two points represent the values of the design variables that minimize (for the Utopia) and maximize (for the Nadir) the functions f_1 and f_2 .

The obtained results are presented more clearly in the following tables:

Table 1.2: Variable values for the Binh and Korn function

Variable	x_1	x_2
Utopia for f_1	0.0	0.0
Utopia for f_2	5.0	3.0
PseudoNadir for f_1	5.0	3.0
PseudoNadir for f_2	0.0	0.0
Nash	0.0	3.0
NB_nadir	2.1	2.1
NB_nash	1.7	1.7
KS_nadir	2.1	2.1
KS_nash	1.8	1.8

Table 1.3: Objective values for the Binh and Korn function

Objective_Functions	f_1	f_2
Utopia	0.0	4.0
PseudoNadir	135.9	50.0
Nash	35.9	29.0
NB_nadir	36.3	16.5
NB_nash	22.3	22.2
KS_nadir	36.6	16.4
KS_nash	24.6	21.1

For the Chankong and Haimes function, instead, only graphical results are reported to avoid excessive verbosity. In particular, the results for the variables are depicted in Figure 1.9, while the results for the objective functions are shown in Figure 1.10:

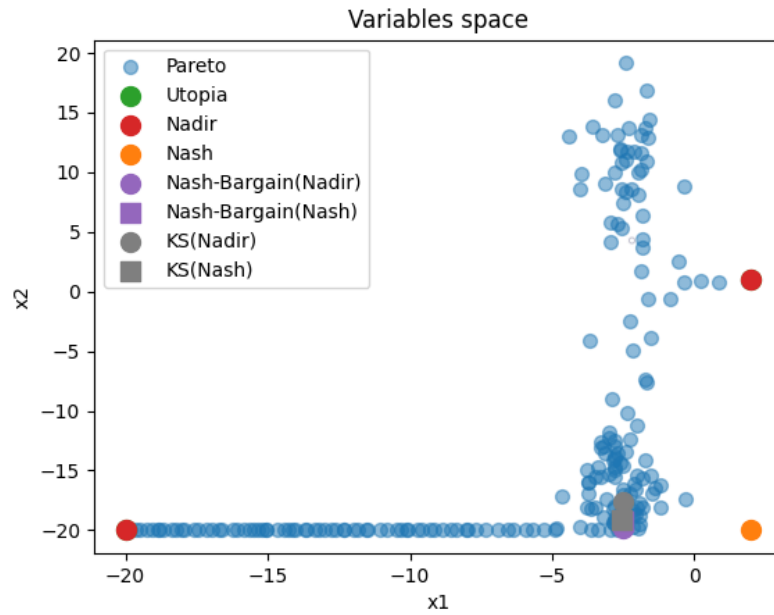

Figure 1.9: Design Variable Space of the Chankong and Haimes Function

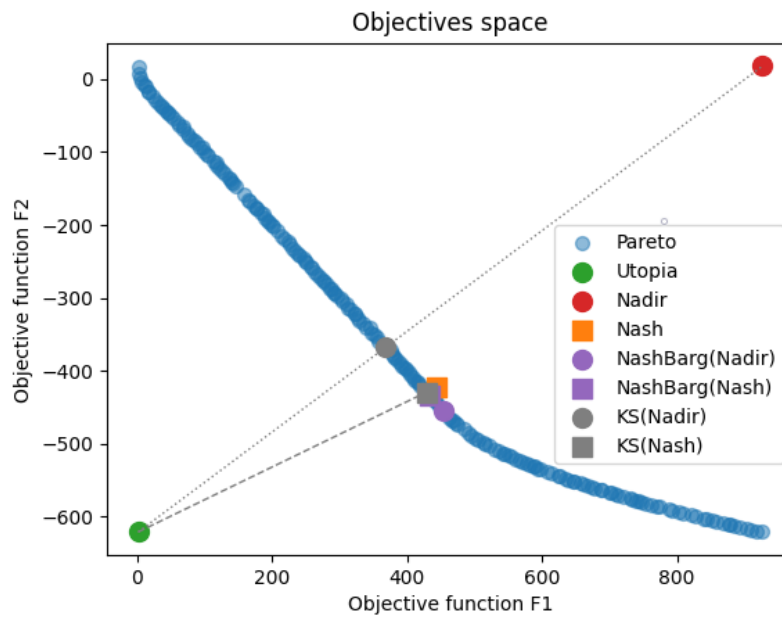

Figure 1.10: Objective Functions Space of the Chankong and Haimes Function

Since these benchmark problems have only two design variables and two objective functions, it is possible to provide a graph similar to that in Figure 1.1, which allows for

a detailed analysis of the functioning of the non-cooperative Nash algorithm, iteration by iteration. Specifically, for the Binh and Korn function, it would be as follows:

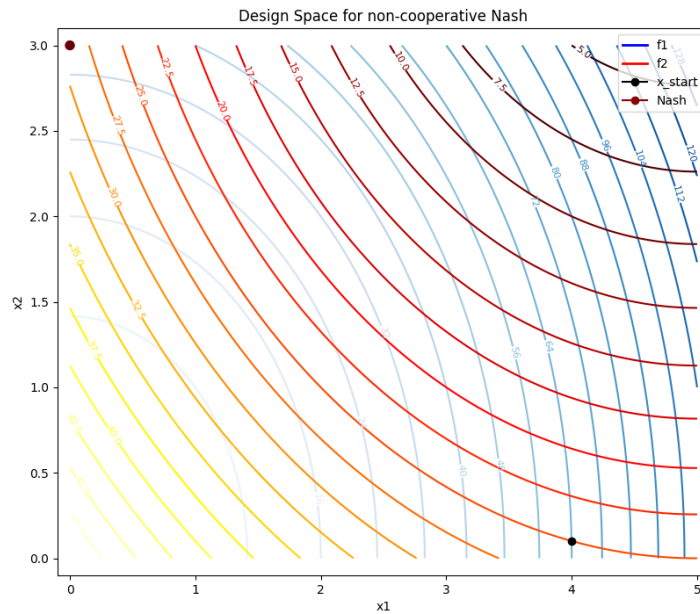

Figure 1.11: Design Space for non-cooperative Nash

As can be observed from Figure 1.11, starting from the initial point x_{start} , objective function f_1 is minimized by varying only x_1 and therefore it moves to the left until reaching the value $x_1 = 0$. At the same time, objective function f_2 is minimized by varying x_2 and it moves upwards, reaching the value $x_2 = 3$. Thus, the new value for the next iteration is created as $x = (0, 3)$ which, due to the simplicity of the functions, is already the equilibrium point. The second iteration confirms this, identifying it as a non-cooperative Nash point.

Subsequently, the multi-objective optimization for the Viennet function was carried out, taking into account the considerations for the three-dimensional space of the objective functions previously reported. Therefore, the obtained results for the variables are presented in Figure 1.12:

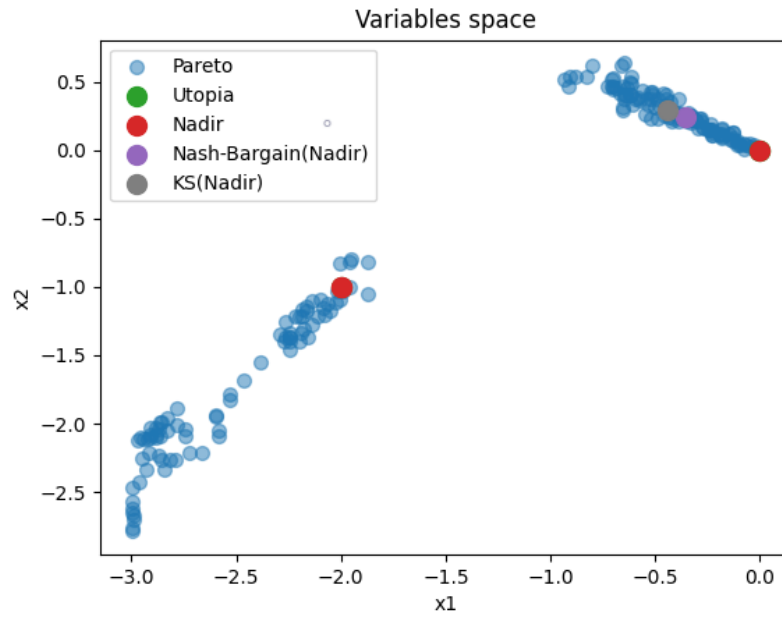

Figure 1.12: Design Variable Space of the Viennet Function

while the values of the results for the objective functions are reported in Figure 1.13. The obtained results are presented more clearly in the following tables:

Table 1.4: Variable values for the Viennet function

Variable	x_1	x_2
Utopia for f_1	0,0	0,0
Utopia for f_2	-2,0	-1,0
Utopia for f_3	0,0	0,0
PseudoNadir for f_1	-2,0	-1,0
PseudoNadir for f_2	0,0	0,0
PseudoNadir for f_3	-2,0	-1,0
NB_nadir	-0,4	0,2
KS_nadir	-0,4	0,3

Table 1.5: Objective values for the Viennet function

Objective_Functions	f_1	f_2	f_3
Utopia	0,0	15,0	-0,1
PseudoNadir	1,5	17,0	0,2
NB_nadir	0,3	15,8	-0,1
KS_nadir	0,4	15,6	-0,1

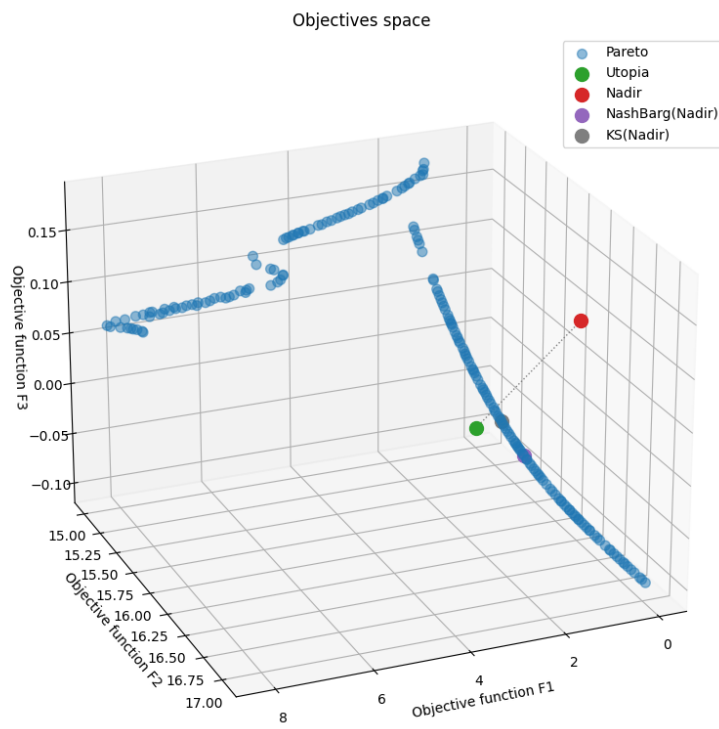

(a)

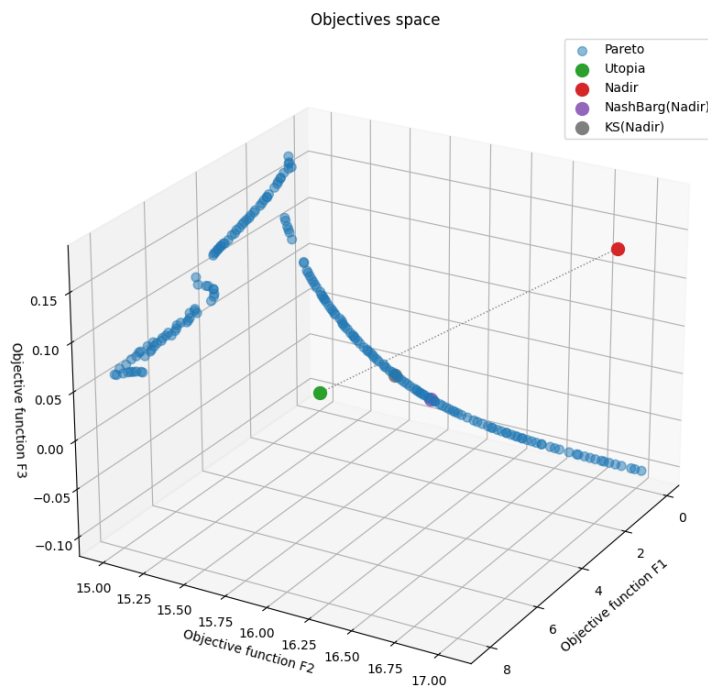

(b)

Figure 1.13: Objective Functions Space of the Viennet Function

Finally, as mentioned earlier, specific problems were created to test the non-cooperative Nash approach in the case of three objective functions. For the problem expressed in Equation 1.2.1, only the graphical representation of the objective function results is reported, Figure 1.14:

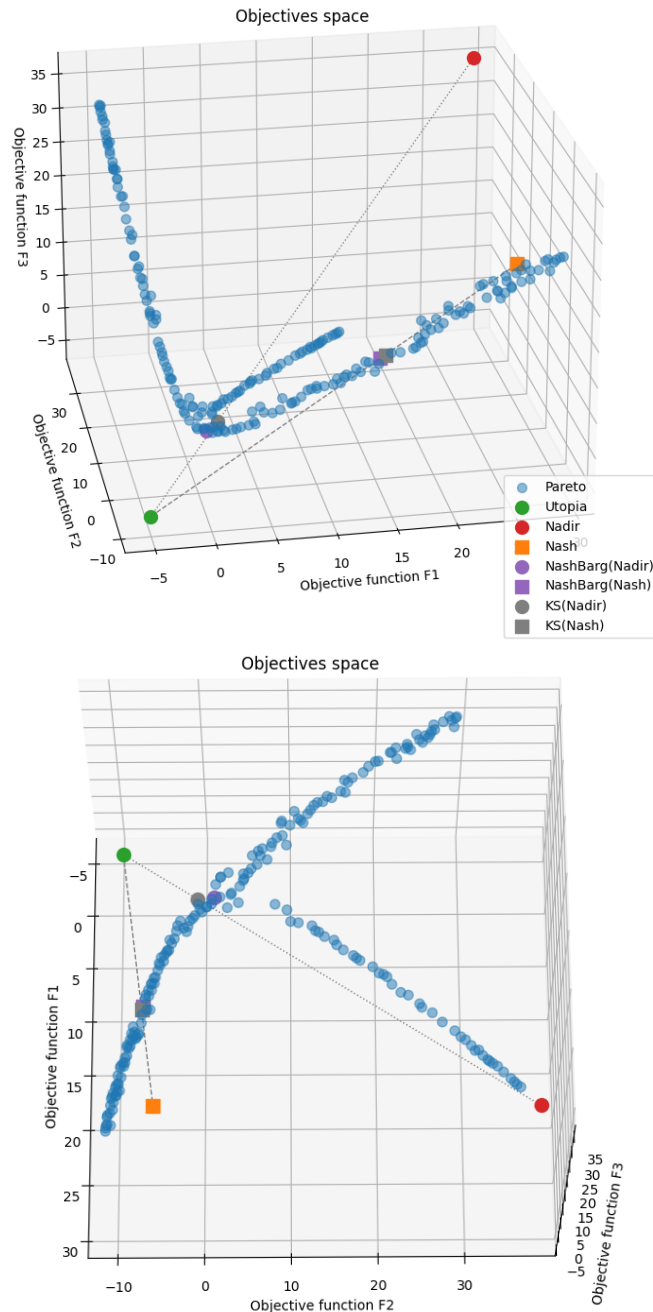

Figure 1.14: Objective Functions Space of problem1

Having conducted these and other tests, sufficient confidence was gained in the proper functioning of the implemented multi-objective optimization through Game Theory script. Consequently, it became possible to proceed with the thesis and integrate it with the CSCoupled simulation program for collective self-consumption and renewable energy communities.

1.2.2 Choice of the single-objective minimization algorithm

Although the problems addressed are multi-objective in nature, due to the implementation of the optimization algorithm, it is still necessary to perform single-objective minimizations.

For this purpose, several tests were conducted on the benchmark functions using the following minimization solvers:

- *shgo* from scipy [18]: a global optimization method that finds the global minimum of a function using Simplicial Homology Global Optimization. This algorithm is suitable for solving generic black-box optimization problems and has demonstrated convergence on problems with nonlinear objective functions and with constraints [19];
- *GA: Genetic Algorithm* from pymoo [20]: a global optimization method that simulates natural evolution. It starts by generating an initial population, evaluates individuals based on the problem, and then uses fitness-based selection, crossover operator, and mutation to obtain optimal solutions over multiple generations.
- *DE: Differential Evolution* from pymoo [21]: a global optimization algorithm that utilizes differential crossover to generate new solutions. The algorithm combines the differences between individuals to create new candidate solutions. This technique is effective in finding global solutions for complex optimization problems;
- *Nelder Mead* from pymoo [22]: a direct search algorithm based on a simple geometric concept. It employs a combination of reflection, expansion, and contraction operations to iteratively adapt a simple polyhedron to an objective function. It is capable of approaching a local minimum by adapting to changes in the function's topology [23];

- *Pattern Search* from pymoo [24]: an optimization algorithm that evaluates the surrounding points to find a local minimum of a function. It does not require differentiability and can adapt to nonlinear problems or with complex constraints. The algorithm is based on the search for predefined patterns to guide the exploration of the solution space. While primarily it is a method for local minimization, it can be combined with other techniques to enhance the search for a global minimum. [25];
- *ES: Evolutionary Strategy* from pymoo [26]: similar to the Genetic Algorithm since both simulate natural evolution. However, it employs a stochastic parent selection process where all individuals contribute to the next generation. Furthermore, unlike the *GA*, the *ES* does not use a crossover operator and, instead, solutions are directly mutated through small random modifications of their values.

This selection of solvers provides various optimization strategies to address the problems within the context of the thesis, considering their effectiveness, adaptability, and specific properties.

The population-based methods, despite producing similar results to other approaches, require longer computation time compared to *shgo*, *Nelder Mead*, and *Pattern Search*. This factor may present challenges in future implementations. On the other hand, the three aforementioned methods have proven to be the most promising in terms of computation time and result accuracy. However, considering that the latter two are local search methods, the decision was made to utilize *shgo* instead for the subsequent analysis, given its global optimization capabilities.

Chapter 2

Cscoupled

In this thesis work, the aim is to perform a multi-objective optimization of a collective self-consumption system. As stated in the Italian directives [3], this is a specific mode of sharing electrical energy in which all end-users are located in the same building or condominium.

However, the condominium can be modeled in two different configurations [27]:

- Physical self-consumption: It involves a direct private connection between the generation system and domestic/common users, with a single Point of Delivery (POD) to the public grid, as shown in Figure 2.1a;
- "Virtual" self-consumption: It involves the use of the public grid for energy exchange between generation and consumption units, as illustrated in Figure 2.1b.

Nevertheless, despite the fact that the "virtual" self-consumption configuration implies that all the energy generated by the system is injected into the grid and the entire energy demand is met through the grid, from a practical standpoint, these two configurations can be considered equivalent. This is possible due to the proximity of the consumption units to the generation installation. The difference lies instead in regulatory and economic aspects, as the current regulations ([3], [27]) require each consumption unit (such as each household) to be connected to the public grid through its own POD. This requirement is implemented to ensure consumer freedom in choosing an energy supplier and to enable free entry and exit from the collective self-consumption. These principles are only adhered to in the virtual configuration, which will therefore be the subject of the analysis.

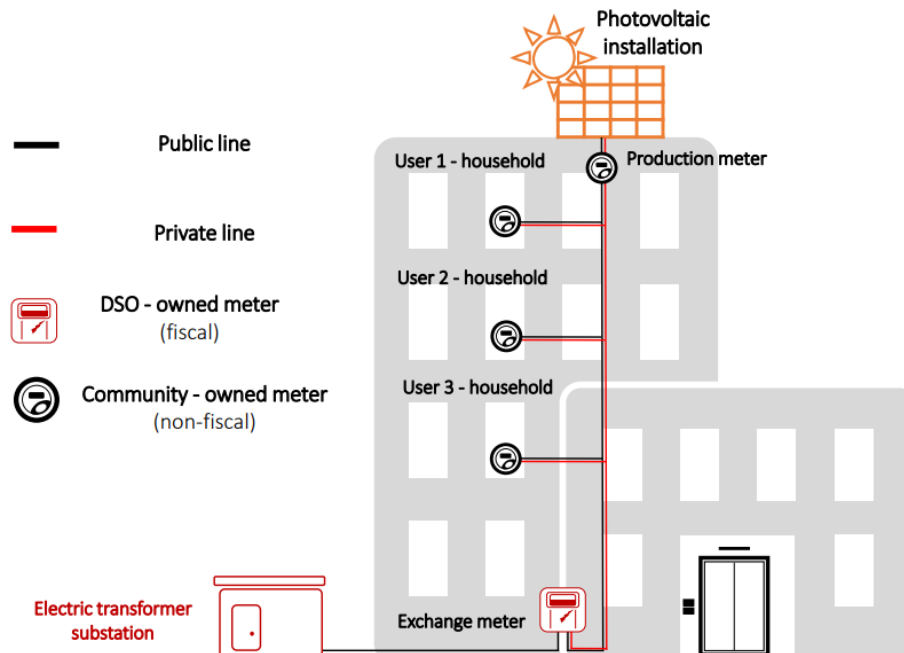

(a) *Physical self-consumption scheme*

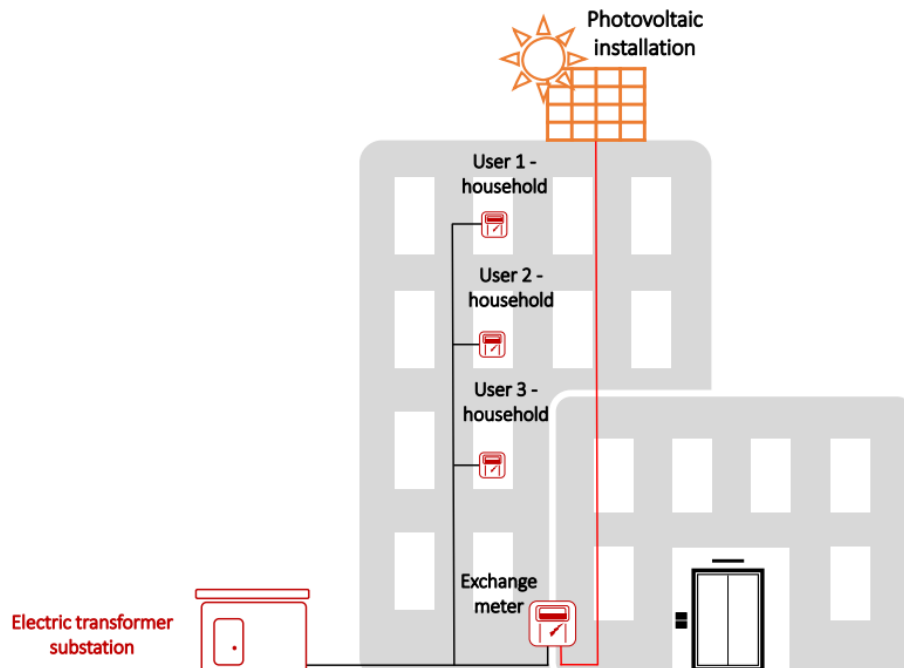

(b) *Virtual self-consumption scheme*

Figure 2.1: Schemes of a collective self-consumption (adapted from [27])

To simulate the behavior of collective self-consumption, the Python program CSCoupled is utilized, which is an adaptation of the more general program RECoupled ([28],

[29]), tailored for individual collective self-consumption. This program considers the condominium as a single energy node connected to the national power grid, through which it can withdraw the missing electrical energy or inject surplus energy.

Currently, energy sharing exclusively regards electricity. However, within the energy node, various energy vectors can be considered by utilizing renewable technologies, storage systems, and conversion components (such as heat pumps). Figure 2.2 provides a detailed, albeit not necessarily exhaustive, example of a multi-vector energy node. In addition to diverse technologies, connections with other energy networks, such as natural gas and district heating/cooling, are also considered to meet local energy needs. Nevertheless, energy sharing on these networks is not yet regulated, and therefore, self-generated energy must be consumed locally.

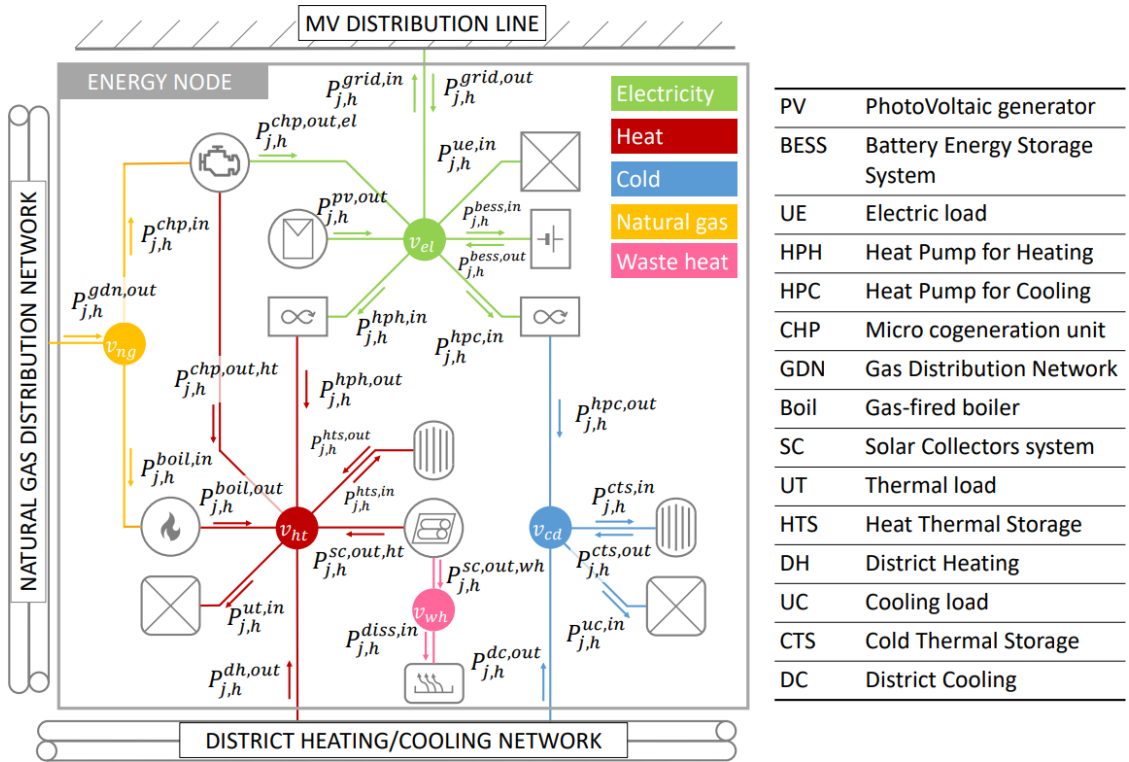

Figure 2.2: Schematic representation of an active energy node with multiple energy vectors (adapted from [28])

2.1 Components

In CSCoupled, the different components of collective self-consumption are simulated. The main ones include:

- Generatio plant;
- Boiler;
- Heat Pump;
- Consumption units and electric grid.

Generatio plant

According to the Decree Law 162/2019 [3], the generation system of a collective self-consumption must be based on renewable energy sources. There are no restrictions on the specific type of system, which could be a photovoltaic system, a micro-hydroelectric system, small wind turbines, and so on. However, considering the residential context and the constraints on configuration, it seems that the photovoltaic system is the most suitable and easily implementable choice [30].

In the context of CSCoupled, the specific choice of the generation system is not crucial since it only requires the hourly production profiles of the unit from the renewable installation, regardless of the technology used.

Boiler

The boiler used in the context of the collective self-consumption is a natural gas boiler. Its main purpose is to heat water used for domestic purposes, such as space heating. The choice of a natural gas boiler is based on its efficiency and reliability in providing hot water quickly and continuously.

Heat Pump

The improving performance of heat pumps is paving the way for a broader adoption of this technology, contributing to the electrification and decarbonization of energy consumption in residential buildings. In fact, the heat production by a heat pump is generally more energy-efficient compared to a traditional boiler, resulting in expected positive effects in terms of energy savings, costs, and emissions [31]. For these reasons,

the integration of an Air Source Heat Pump (ASHP) is introduced within the collective self-consumption system to complement the existing conventional boiler.

However, it is necessary to avoid potential oversizing of the heat pump in order to limit the economic impact of this technology, while maximizing the heat production from this component compared to that of the existing gas boiler. In this perspective, the maximum capacity of the heat pump is not calculated based on the overall peak heating demand but according to the average peak demand during the coldest months.

The electrical consumption of the heat pump, required for the simulation, is calculated using the Coefficient of Performance (COP).

Consumption units and electric grid

The consumption units (individual apartments) are considered as "passive" energy destinations, meaning that their power demand must be met at all times and their consumption profile cannot be modified. On the other hand, the electrical grid is simply modeled as a source/sink of energy, with the only limitation being the maximum power it can provide. Since the system is virtual, the grid satisfies the entire demand of the consumption units. The maximum power is the sum of the individual contractual powers that can be supplied at the POD of the homes, which is typically around 3 kW in the residential context.

2.2 Input data

CSCoupled requires few input data to run the simulation. Specifically, the following information needs to be provided in CSV format: hourly production profiles from the renewable generation plant, energy demand profiles of the apartments, and the electrical and thermal demand of the entire condominium. Additionally, some numerical values are required within the script, such as the number of apartments, the sizes of the renewable generation plant and heat pump in *kW*, and all the costs of the various energy flows, as well as the investment, operational, and maintenance costs of the various installed devices.

2.3 Simulation of the energy node

The simulation process of CSCoupled involves the calculation of energy flows within the collective self-consumption system, considering all energy vectors and technologies involved.

To better understand how the optimization in CSCoupled works, it is advisable to provide a clearer explanation of what happens within the energy node of the condominium.

The electric energy generated by photovoltaic panels can be utilized in various ways. Firstly, it is used by the heat pump for conversion into thermal energy, if necessary. If there is still available electric power, it is consumed by the consumers to meet their own electrical needs. As mentioned earlier, this is done through the national grid, but since production and consumption are in close proximity, it is considered as physical self-consumption. Finally, if there is still excess energy, it can be fed back into the electrical grid. On the other hand, consumers can meet their energy demand by directly utilizing the energy from the production plant, as mentioned earlier, or, in the case where the energy demand is still not fulfilled, they can purchase electricity from the grid.

The heat pump, instead, can utilize energy from the photovoltaic panels or from the electric grid to produce hot air for the condominium when needed. In case the available energy is not sufficient, the backup boiler comes into operation to provide the additional energy.

The tool uses the input data to determine all energy flows within the collective self-consumption and subsequently, the procedure calculates the annual data required for energetic and economic assessment, through Key Performance Indicators (KPIs), for the different configurations.

2.4 Key Performance Indicators

KPIs are used to evaluate the performance of collective self-consumption once it has been simulated, typically on an annual basis. Two groups of KPIs are considered: energy-related and economic-related.

The energy-related KPIs taken into account are self-consumption and self-sufficiency. Self-consumption indicates the percentage of internally generated energy that is actu-

ally consumed within the system, rather than being injected into the electrical grid. Self-sufficiency, on the other hand, refers to the ability to meet one's own energy needs without relying on external sources. A system is considered self-sufficient when it can generate all the energy required to cover its internal consumption without having to purchase energy from the electrical grid.

These energy indicators, in addition to their definition, also provide insights into the environmental situation and the utilization of the grid. In particular, maximizing self-sufficiency guarantees a reduction in carbon dioxide production and the use of the national electrical grid, as less energy is drawn from it. On the other hand, maximizing self-consumption does not provide significant information regarding the reduction of carbon dioxide emissions. This is because a high value of self-consumption could simply result from a small amount of energy being consumed locally. However, maximizing self-consumption implies a lower injection of energy into the grid, which, if excessive, could cause issues in the electrical system as, while it was designed to supply all the energy demanded by consumers, it was not intended for high levels of decentralized power injection.

The economic KPIs considered are, instead, the Internal Rate of Return (IRR), which represents the effective interest rate that makes the Net Present Value of a cash flow equal to zero and the Percentage Cost Reduction (PCR), which is defined to compare the annual costs of the collective self-consumption scheme with those in which this configuration is not adopted.

To calculate the economic indicators, it is necessary to consider various incentives. However, since the economic scenario for renewable energy communities and collective self-consumption is still evolving, it was decided to consider incentives from past years. In particular, the Italian government provides incentives for shared energy, as it reduces the demand for energy from the national grid. According to the Decree Law 162/2019 [3], the energy that is virtually shared is defined as the minimum hourly value between the total energy supplied to the grid and the total energy drawn from the grid, either instantaneously or through a storage system. However, a portion of the production may still be physically self-consumed, for example, to power the heat pump or shared services such as an elevator or common area lighting. In this case, the energy supplied to the

grid must be reduced by the amount of energy that is directly self-consumed.

In particular, globally, the economic value of shared energy in collective self-consumption configurations can be approximately considered as 110 €/MWh [32]. Furthermore, all the energy injected into the grid can benefit from the dedicated withdrawal service and be sold at the zonal hourly market price, which is generally lower than the retail price [32].

Additionally, the Italian government has implemented an incentive program aimed at promoting the adoption of renewable energy generation in the residential sector. According to this program, 50% of the capital costs for installing a photovoltaic system and 65% of the investment costs for a heat pump can be recovered over a ten-year period through tax deductions [33]. However, it is important to clarify the situation regarding the heat pump. With an average lifespan of approximately 10 years, once this period has expired, it becomes necessary to purchase a new unit. Nevertheless, it is crucial to note that the incentives are only applicable when replacing a traditional production system. Therefore, when purchasing a new heat pump, the incentives are no longer available.

It is important to note that different KPIs can conflict with each other and therefore cannot be maximized simultaneously. The sizing of collective self-consumption thus becomes a multi-objective problem.

Chapter 3

Case Study

In this thesis, an analysis on collective self-consumption is carried out within a multi-family residential building. In order to ensure greater generality, the simulation is based on the most common type of multi-family building in Italy, specifically those constructed between 1961 and 1975, as illustrated in Figure 3.1.



Figure 3.1: Share of residential building in Italy by construction period (adapted from [31])

The case study considered in this thesis shares similarities with the one described in the article by Canova et al. [31]. In the analyzed building, there is indeed a rooftop

photovoltaic system installed to partially cover the electrical energy demand, along with an heat pump supported by an auxiliary boiler for the thermal demand, as reported in the aforementioned article. The detailed operation of these components is described in Section 2.3, while a schematic representation of collective self-consumption is illustrated in Figure 3.2.

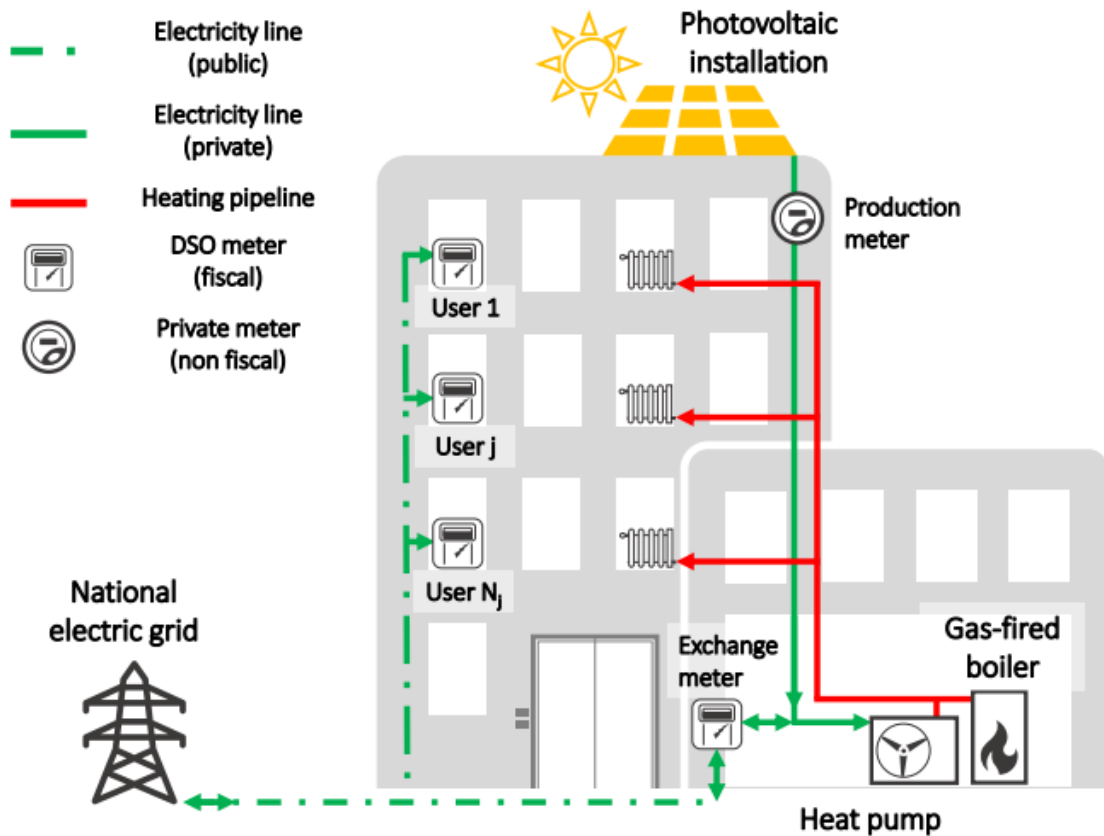

Figure 3.2: Collective self-consumption in multifamily residential building [31]

Figure 3.3 provides a clear representation of the power flows within the analyzed collective self-consumption setup. Energy flows within the building are divided into two parts: the electrical side and the thermal side. On the thermal side, the energy demand of the apartments can be met through two options: the utilization of a heat pump and the use of a gas boiler. On the electrical side, the energy generated by the photovoltaic system can be used to power the heat pump, satisfy the electrical demand of the con-

sumers, or be sold back to the grid. When photovoltaic production is lower than the internal demand or absent, electricity is purchased from the grid. For modeling purposes, domestic users within the building can be treated as a virtual aggregated load that draws from the grid an amount of electrical energy equal to the sum of the households' demands.

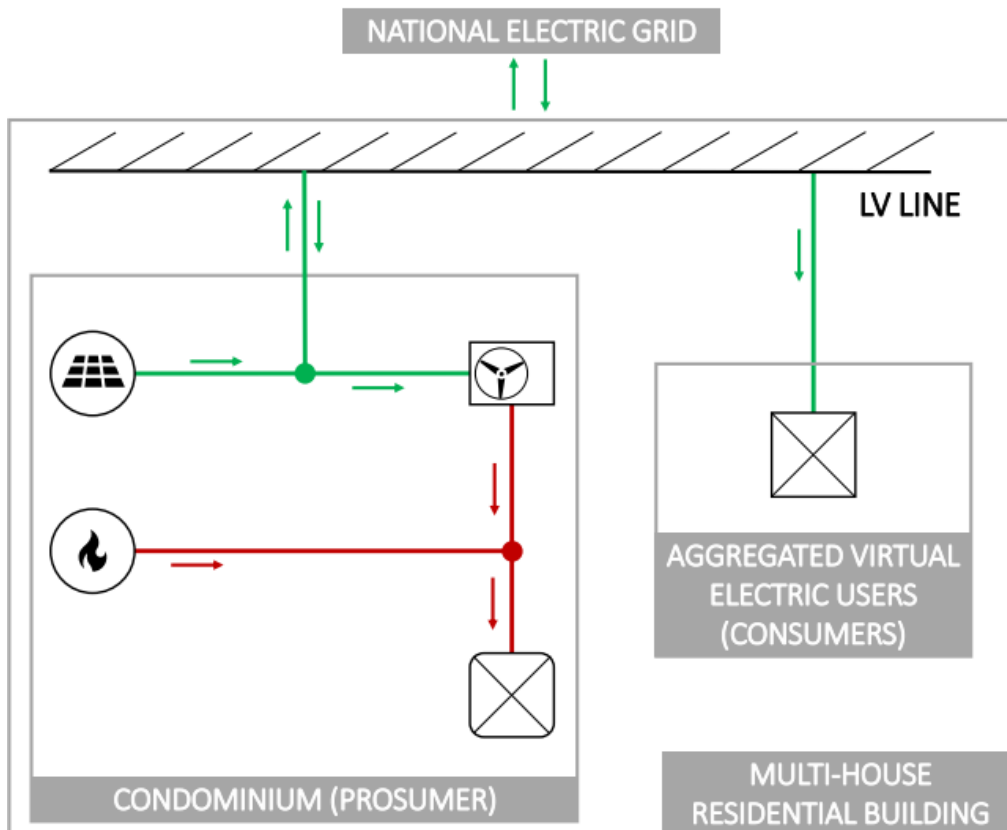

Figure 3.3: Scheme of the energy flows in the collective self-consumption configuration (adapted from [31])

In the context of the analysis that will follow, two distinct scenarios are explored for simulating the collective self-consumption. In the first scenario, referred to as the Purely Electrical scenario, households install only a rooftop photovoltaic system to partially cover their electrical energy needs. The centralized heating demand, on the other hand, is met through a gas boiler. In the second scenario, referred to as the Electrical and Thermal scenario, one additional component is introduced, namely a heat pump, to partially fulfill the heating demand while simultaneously increasing the consumption of

renewable electrical energy at the local level.

Before proceeding with the simulations, it is necessary to import the relevant input data for the proper configuration of the scenarios.

3.1 Case study input data

The initial data required for the simulation are provided in Section 2.2.

In particular, the number of apartments was set to 40 as it represents the average value for buildings constructed between 1961 and 1975, as reported by Corrado et al. [35]. As for the costs related to energy flows, investments, and the operation/maintenance of the installed devices, this information was extrapolated from [31].

Particular attention should be paid to other single numerical value data to be included in the script, namely the sizes in kW of the renewable generation system and the heat pump. These variables will be subject to the multi-objective optimization through Game Theory, and depending on the simulation case, they may vary or be set to zero, depending on whether they are used and their optimal size is sought, or whether they are absent in the simulation. It is therefore important to establish size limits for these technologies. These have been determined by technical constraints, such as the available roof area and the dimensions of the heat pump, or approximately calculated to meet the demand of the consumers, Section 2.1.

Finally, the CSV data has been determined as described in the following sections.

3.1.1 PV's production profiles

The required data for the photovoltaic system, as mentioned earlier, are the unitary hourly production profiles. These data have been obtained using the online tool PVGIS (PhotoVoltaic Geographical Information System) developed by the JRC (Joint Research Center) [34], with the reference location set to Torino. PVGIS uses solar irradiation values and external temperature (which affects the efficiency of the photovoltaic panels) to estimate the energy generated during each hourly interval.

3.1.2 Thermal demand of the building

The data concerning the thermal demand of the building were extrapolated from the article by Canova et al. [31]. Specifically, Canova et al., after selecting the reference building with the physical characteristics reported in the article by Corrado et al. [35], estimated the heating demand using a simplified steady-state approach. In this approach, only the thermal losses through transparent/opaque surfaces and ventilation are considered, while contributions from internal loads, solar gains, and the thermal mass of the building are neglected. The approach proposed in [31] takes into account the hourly variation of air temperature and assumes a fixed reference indoor temperature. Consequently, the hourly thermal load for heating the reference building can be calculated by summing the following contributions: heat loss through external walls, heat loss through the roof, heat loss through the ground, heat loss through internal walls, heat loss through transparent surfaces (e.g., windows), and heat loss due to ventilation. In the article [31], the necessary data were extracted from the JRC dataset available for all European Union countries [36].

Finally, as indicated in [31], the thermal demand was adjusted taking into account the Italian regulations that regulate the daily and seasonal activation/deactivation of heating systems based on the annual heating degree days and specific climatic zones [37].

3.1.3 Electricity demand of the building

The considered multifamily residential building, as mentioned earlier, consists of 40 apartments. Under the assumption that all families have joined the collective self-consumption, it is necessary to estimate the hourly load profile of the families within the building. This has been extrapolated from the article by Canova et al. [31], where the hourly load profile is derived by assuming the annual demand of the families and considering a normalized load profile for residential end-users. Subsequently, the normalized profile is appropriately scaled to preserve the aggregate annual electricity demand.

Finally, the hourly load profile of the families is combined with the electricity demand of the heat pump, so that the total electricity consumption of the residential building is also influenced by the thermal demand. This highlights the interconnected nature of the

analyzed configuration in the present study. Other electricity consumptions arising from the common areas of the reference building, such as common area lighting, are neglected.

3.2 Energetic evaluation

CSCoupled then utilizes the input data to simulate the energy node in the collective self-consumption and calculates the following energy flows:

- The energy injected into and withdrawn from the grid by the building, excluding consumers, solely dependent on the energy from the photovoltaic system and heat pump consumption;
- The input energy (in the form of gas) and output power (in the form of thermal power) from the backup boiler;
- The input electrical power and output thermal power from the heat pump;
- The shared energy;
- The normalized load of domestic consumers;
- The thermal power output from the boiler in the case without collective self-consumption and, thus, without the heat pump;
- The normalized load of domestic consumers in the case without collective self-consumption. It is important to note that this value remains constant regardless of the presence or absence of collective self-consumption, as the energy demand of consumers does not vary.

These data are then used to calculate the energy and economic KPIs previously described, Section 2.4.

3.3 Business model

It is now necessary to define an appropriate business model for this configuration in order to evaluate the key economic performance indicators.

Firstly, it is important to clarify how the investment for implementing collective self-consumption is carried out. While it is possible for individual consumers to individually bear the investment costs, this analysis assumes the presence of an external investor

who takes on the expenses of implementation and management of the collective self-consumption. This choice has been made to lighten the initial burden for consumers, who do not have to incur any costs and therefore make the initiative more appealing. All expenses are therefore borne by the external investor, who is not part of the collective self-consumption but, as a result, expects an economic return for the entire project duration, which has been set at 20 years.

The investment analysis is considered from three perspectives: that of the investor, who has covered all the expenses; that of the "condominium", which focuses only on the common consumption, particularly the thermal consumption in the analyzed case; and that of the consumers, represented by the 40 families that include all the electrical consumption. The distinction between "condominium" and consumers has been made in order to clearly highlight the economic benefits derived from the thermal or electrical perspectives.

As a result, two possible business models have been hypothesized. In the first model, revenues and savings are divided among consumers, condominium, and investor using profit-sharing variables. In the second model, on the other hand, all revenues and savings are exclusively allocated to consumers and the condominium, on the condition that they purchase electricity only from the investor at an increased price.

Subsequently, a further analysis highlighted that the second model requires the development of a business model for the external electricity supply by the investor to meet consumer demand and, therefore, it was decided to adopt the first business model.

3.3.1 Business Model's implementation

The analyzed Business Model involves the allocation of savings generated by the creation of collective self-consumption among the Investor, the Consumers, and the Condominium, using two profit distribution variables: β_{cons} and β_{build} respectively.

It is important to clarify that consumers maintain their energy demand constant, but through the use of shared energy, they receive a portion of the economic incentives for this energy as well as for the energy fed into the grid. It can be stated that this component of collective self-consumption generates "revenues." On the other hand, the condominium, thanks to the heat pump, reduces its demand for gas supplied by the national grid,

which results in potential economic savings. Although these are not actual "revenues", the expenses related to the raw material decrease for the condominium.

Therefore, the "economic benefits" derived from collective self-consumption can be divided into two categories: consumer benefits, $benefits_{cons}$, which include incentives for shared and fed-in energy, and condominium benefits, $benefits_{build}$, which represent the reduction in expenses for the thermal energy component. The latter corresponds to the difference between the expenses incurred in a situation without collective self-consumption and the expenses in a situation with collective self-consumption.

It is therefore possible to define the cash flows for the three parts considered:

- the cash flows for consumers are determined by the expenses for the electricity demand, exp_{vwith} , and by a part of the $benefits_{cons}$, in particular:

$$cf_{cons} = -exp_{vwith} + (1 - \beta_{cons}) \cdot benefits_{cons} \quad (3.3.1)$$

- the cash flows for the condominium, on the other hand, include expenses related only to the condominium's electricity withdrawn, exp_{with} , and gas expenses, exp_{gas} . Additionally, a portion of the $benefits_{build}$ needs to be subtracted. Therefore, it is:

$$cf_{build} = -exp_{with} - exp_{gas} - \beta_{build} \cdot benefits_{build} \quad (3.3.2)$$

Although it may seem that the expenses are increasing, it is important to note that, thanks to the use of a heat pump, the absolute costs remain lower compared to those incurred in a situation without the implementation of collective self-consumption;

- finally, the cash flows for the investor include, as already mentioned, the initial investment $capex$, the operating costs $opex$, and the missing portions of the economic benefits, i.e.:

$$cf_{inv} = -capex - opex + \beta_{cons} \cdot benefits_{cons} + \beta_{build} \cdot benefits_{build} \quad (3.3.3)$$

It is necessary to further clarify the usage of β_{cons} and β_{build} . These variables do not have a predefined value but will be some of the variables utilized in multi-objective optimization through Game Theory. Therefore, they can vary within predefined limits in order to determine their optimal value. Specifically, the limits have been set between 0.1 and 1, where the lower limit has been defined to ensure a minimum return for the investor during the optimization process.

3.4 Simulation and Game Theory MOOP integration

It is now possible to simulate the collective self-consumption of the case study using CSCoupled and determine its optimal configurations through multi-objective optimization using Game Theory.

This optimization process, as already expressed in Section 1.2, ultimately yields seven points. The first three points, namely Utopia, Nadir, and non-cooperative Nash equilibrium, serve as the starting point for determining the actual solutions. The sought-after solutions are, in fact, Nash Bargaining equilibrium and Kalai-Smorodinsky equilibrium. Both of these methods strive for the Utopia, and two solutions were found by setting the Nadir point as the disagreement point, while the other two were obtained from the non-cooperative Nash equilibrium. The determination of this point, as suggested in Section 1.1.1, involves a combination of sensitivity analysis and considerations of the physical behavior of different components when allocating the design variables.

To perform the optimization, it is necessary to first define the objective functions to be associated with the players and the variables that influence them. These settings may vary depending on the specific case under consideration, but it is crucial to bear in mind that, due to the way the algorithm is implemented in the context of non-cooperative Nash equilibrium, the number of variables must be equal to or greater than the number of players and, consequently, the number of objective functions that need to be analyzed (see Section 1.1.1). It was therefore decided to analyze two different cases: a Purely Electrical Case and an Electrical and Thermal Case.

Purely Electrical Case

The Purely Electrical Case is the simplest scenario as it involves only two design variables: the size of the photovoltaic system and the variable for distributing the economic benefits of the consumer. Since there is no heat pump, the thermal situation of the condominium remains unchanged compared to the case without collective self-consumption, and therefore, it is not necessary to consider the condominium benefits ($benefits_{build}$). With only two design variables, if the non-cooperative Nash equilibrium is also desired to be analyzed, only two objective functions can be included. The chosen functions include the Internal Rate of Return for the investor and the Percentage Cost Reduction

for consumers.

For this case, having only two design variables, it is also possible to compare it with traditional multi-objective optimization and find the entire Pareto Front and the most commonly selected solution in this case, which is the point closest to the utopia.

However, in the context of optimization through Game Theory, it is also possible to consider a greater number of objective functions. In this case, though, the non-cooperative Nash solution point and the Nash Bargaining and Kalai-Smorodinsky solutions derived from it are lost.

Electrical and Thermal Case

For what concerns the case that includes both the electrical and thermal aspects, the number of involved design variables increases. In this scenario, in fact, in addition to the photovoltaic system, the heat pump is also simulated, resulting in four design variables, including the size of the heat pump and the variable for distributing the economic benefits for the condominium. Therefore, if one also wishes to calculate the non-cooperative Nash equilibrium point, a maximum of four objective functions can be selected for optimization. In this case, to maintain consistency with the Purely Electrical scenario, the following objective functions have been chosen: the Internal Rate of Return for the investor, the Percentage Cost Reduction for consumers, and the Percentage Cost Reduction for the condominium.

For this case as well, given the limited number of design variables and objective functions, it is possible to compare it with traditional multi-objective optimization.

Chapter 4

Analysis of Results

In this chapter, the results of multi-objective optimizations using Game Theory for the examined collective self-consumption will be calculated and analyzed. Initially, the two cases described in the previous chapter will be explored, while also calculating the entire Pareto Front and its point closest to Utopia. This will allow for a comparison with traditional multi-objective optimization.

4.1 Results of the Purely Electrical Case

As mentioned earlier, the design variables in this case are the size of the photovoltaic system, pv_{size} , and the variable for the distribution of economic benefits of the consumers, β_{cons} , while the objective functions are the Investor Internal Rate of Return, irr_{inv} , and the Consumer Percentage Cost Reduction, pcr_{cons} .

For the determination of the non-cooperative Nash equilibrium, the variable pv_{size} has been assigned to the player controlling irr_{inv} , while the variable β_{cons} has been assigned to the player controlling pcr_{cons} .

During the optimization, it was noticed, however, that in this situation the solution values for the IRR of the investor are too low or take on *NaN* (Not a Number) values, causing the malfunction of the optimization algorithm. *NaN* values occur when there are no positive cash flows for the investor.

For this reason, it was decided to implement some constraints on the objective functions, forcing them to take values greater than zero. However, due to the reasons expressed in Section 1.1.1.2, this modification makes it impossible to determine the non-cooperative

Nash point, and consequently, the solutions derived from it are not calculated. Once these constraints are set, it becomes possible to determine the optimal solutions. Specifically, the results of the design variables for these solutions are as follows:

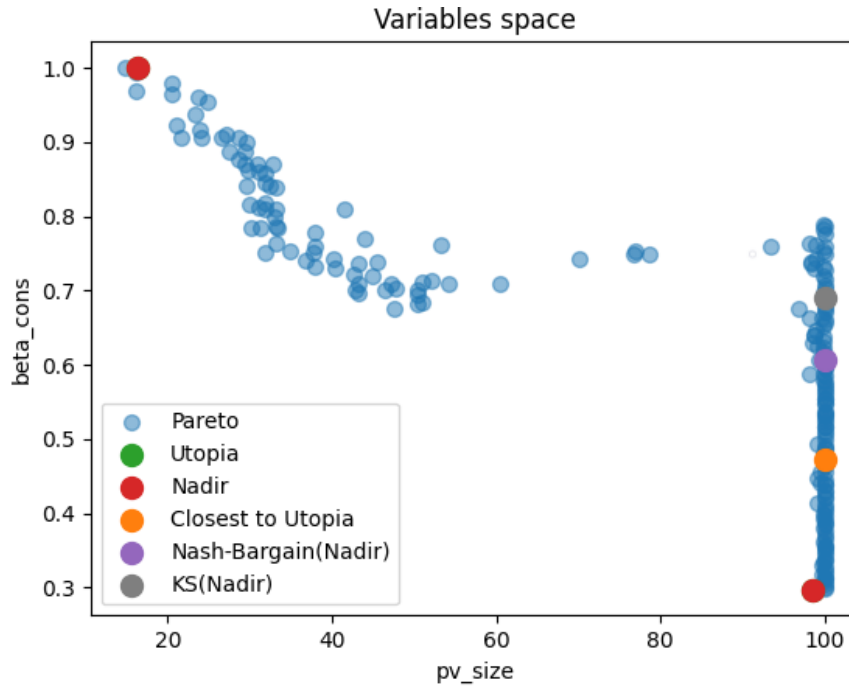

Figure 4.1: Variable space for solutions of the Purely Electrical Case

while the values of the objective functions are the following:

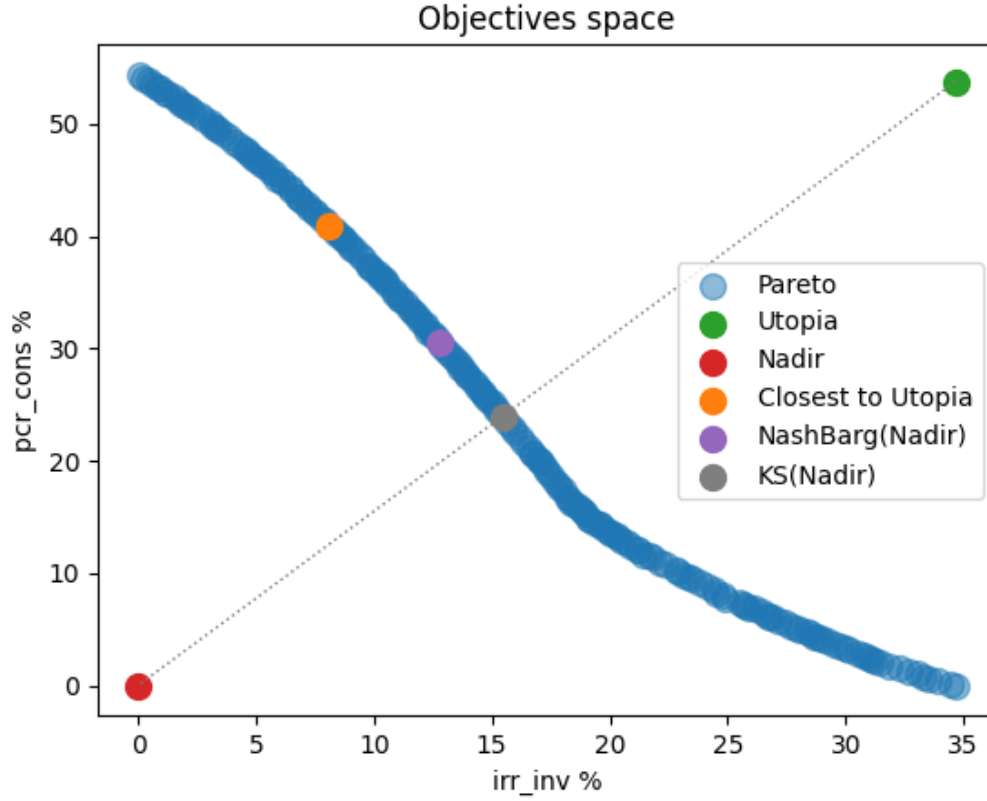

Figure 4.2: Objective function space for solutions of the Purely Electrical Case

The values can be visualized more clearly in a tabular format:

Table 4.1: Values of the variables for the solutions of the Purely Electrical Case

Variable	pV_{size} [kW]	β_{cons}
Utopia for irr_{inv}	16.5	1.00
Utopia for pcr_{cons}	98.5	0.30
PseudoNadir for irr_{inv}	98.5	0.30
PseudoNadir for pcr_{cons}	16.5	1.00
Closest to Utopia	100.0	0.47
NB_nadir	100.0	0.61
KS_nadir	100.0	0.69

Table 4.2: Values of the objective functions for the solutions of the Purely Electrical Case

Objective_Functions	irr_{inv}	pcr_{cons}
Utopia	34.67%	53.79%
PseudoNadir	0.00%	0.00%
Closest to Utopia	8.12%	40.95%
NB_nadir	12.79%	30.55%
KS_nadir	15.46%	23.98%

From Table 4.1, it can be observed an "odd" behavior for the design variables in determining the Utopia point for the irr_{inv} function. As expected, the optimal value is achieved when β_{cons} is equal to 1, indicating that all the incentives go to the player controlling the investor's IRR. However, the calculated size of the photovoltaic system is around 16 kW , rather than taking lower values. This cannot be explained by the constraints imposed on the objective functions, as the PCR of the consumer, by definition, is always greater than zero. In fact, this phenomenon can instead be explained by the behavior of the irr_{inv} objective function with varying pv_{size} , as illustrated in Figure 4.3:

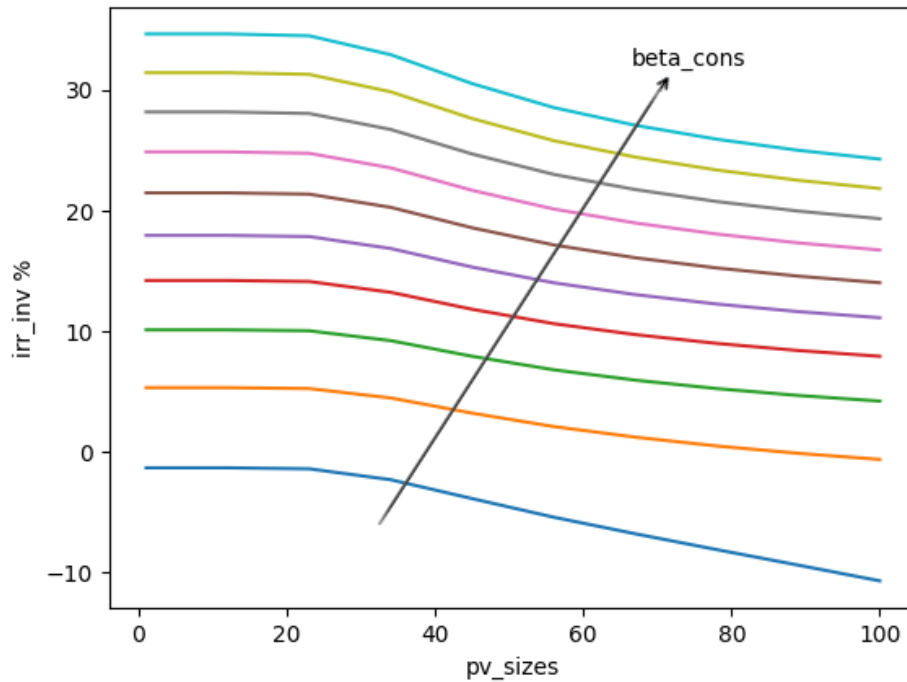
Figure 4.3: Investor's IRR trend as a function of pv_{size}

Indeed, it can be observed that for any value of β_{cons} , the IRR of the investor reaches a

plateau around a pv_{size} value of 20 kW. In other words, below this size of the photovoltaic system, the irr_{inv} remains nearly constant.

This phenomenon can be attributed to the patterns observed in initial investment costs (capex) and operational expenses (opex), as well as the revenues generated from energy sharing and grid injection. Specifically, when considering photovoltaic systems below the 20 kW threshold, the increase in capex and opex costs is nearly proportional to the rise in energy revenues. However, once the 20 kW threshold is surpassed, the shared energy revenues experience a comparatively lower growth rate, leading to a reduction in the investor's Internal Rate of Return.

Another behavior that may appear unusual is the optimization for pcr_{cons} , which does not reach the maximum size of pv_{size} and the minimum value of β_{cons} . However, this phenomenon can be explained by the constraints imposed on the objective functions, specifically the need to maintain the Internal Rate of Return of the investor above zero. It is also worth noting that all the obtained solutions, namely the point closest to the Utopia, the Nash Bargaining, and the Kalai-Smorodinsky, have a nearly identical value for pv_{size} , which is 100 kW, while they differ in the values of β_{cons} . This fact is solely due to the configuration of the Pareto Front, where the "central" points are characterized by high sizes of the photovoltaic system.

Finally, from the analysis of Figure 4.2 and Table 4.2, the values of the objective function solutions can be examined. It is immediately evident that the Point closest to the Utopia is "insensitive" to the conformation of the Pareto Front, as it is simply determined by calculating the minimum distance of its points from the Utopia. Consequently, depending on the specific shape of the Front, this point could also be located in extreme positions and thus favor one objective function over another. In the analyzed case, indeed, this point significantly favors pcr_{cons} over irr_{inv} .

The Nash Bargaining and Kalai-Smorodinsky solutions, on the other hand, due to the axioms they are based on and the chosen disagreement point, ensure greater "fairness" among the different players. This is particularly evident, at least from a purely geometric perspective, when the Nadir is chosen as the disagreement point, since the solutions are central to the front. In the considered case, indeed, the found solutions are central and relatively close to each other, but the Nash Bargaining solution slightly favors the

consumer player, while the Kalai-Smorodinsky solution favors the investor player. The values of these solutions do not have a specific explanation since they consider the game as a "black box," as described in Section 1.1.

A different perspective can be obtained by considering the Nash non-cooperative solution as the disagreement point. Although this solution was not found in the examined case due to the constraints imposed on the objective functions, its behavior can be analyzed through the graphs presented in Section 1.2.1.1. The non-cooperative Nash solution, representing a more realistic equilibrium point with no cooperation between players, may not necessarily be located in a central region, as shown, for example, in Figure 1.14. Consequently, the Nash Bargaining and Kalai-Smorodinsky solutions obtained from this point might not necessarily represent the most "fair" outcomes from a purely geometric perspective, but they could be fair in relation to the relative "strength" of the different players.

4.2 Results of the Electrical and Thermal Case

The design variables for the Electrical and Thermal Case include the size of the photovoltaic system, pv_{size} , the variable for distributing economic benefits of the consumers, β_{cons} , the size of the heat pump, hp_{size} , and the variable for distributing economic benefits of the condominium, β_{build} . The objective functions comprise the Internal Rate of Return for the investor, irr_{inv} , the Percentage Cost Reduction for consumers, pcr_{cons} , and the PCR for the condominium, pcr_{build} .

For determining the non-cooperative Nash solution, pv_{size} and hp_{size} are assigned to the player controlling irr_{inv} , the variable β_{cons} to the player controlling pcr_{cons} , and the variable β_{build} to the player controlling pcr_{build} .

However, also in this scenario, the issues related to the values of the IRR of the investor, encountered in the previous case, arise. Therefore, constraints are once again applied to the objective functions, requiring them to be greater than zero, and the non-cooperative Nash equilibrium and its corresponding solutions are not computed.

Therefore, it is now possible to proceed with multi-objective optimization. The design variable solutions cannot be graphically represented as they exist in a four-dimensional

space, while the objective function solutions are depicted in Figure 4.4:

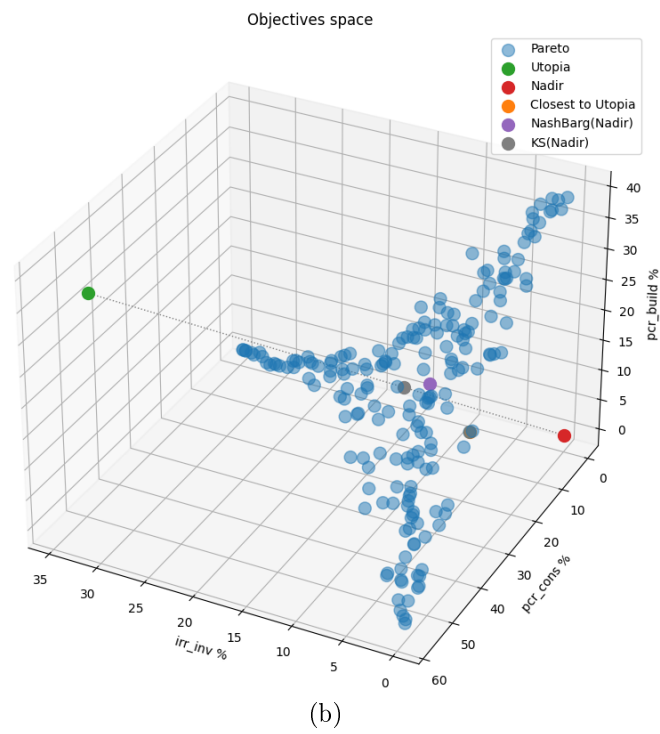
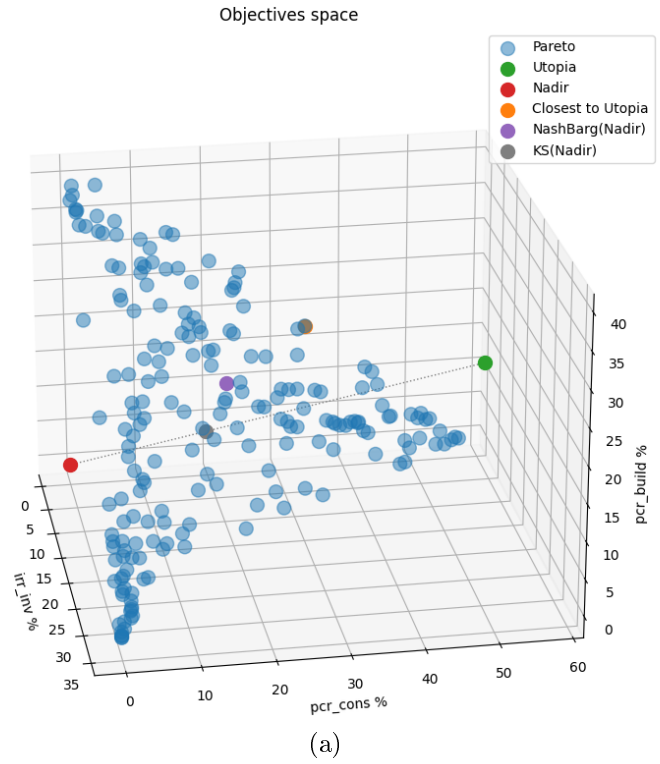

Figure 4.4: Objective function space for solutions of the Electrical and Thermal Case

The values can be seen more clearly in tabular format:

Table 4.3: Values of the variables for the solutions of the Electrical and Thermal Case

Variable	pv_{size} [kW]	β_{cons}	β_{build}	hp_{size} [kW]
Utopia for irr_{inv}	1.0	1.00	1.00	0.0
Utopia for pcr_{cons}	87.0	0.17	0.92	72.5
Utopia for pcr_{build}	100.0	0.78	0.10	78.5
PseudoNadir for irr_{inv}	87.0	0.17	0.92	72.5
PseudoNadir for pcr_{cons}	1.0	1.00	1.00	0.0
PseudoNadir for pcr_{build}	1.0	1.00	1.00	0.0
Closest to Utopia	100.0	0.51	0.20	43.5
NB_nadir	100.0	0.71	0.10	32.5
KS_nadir	100.0	0.77	0.10	23.0

Table 4.4: Values of the objective functions for the solutions of the Electrical and Thermal Case

Objective_Functions	irr_{inv}	pcr_{cons}	pcr_{build}
Utopia	34.67%	48.17%	32.88%
PseudoNadir	0.00%	0.00%	0.00%
Closest to Utopia	0.57%	34.18%	18.06%
NB_nadir	8.40%	20.79%	15.64%
KS_nadir	12.11%	16.83%	11.49%

From table 4.3, it can be observed that the Utopia for irr_{inv} coincides with that of the Purely Electrical Case, with a heat pump size of 0 kW, a value of one for both β parameters, but a value of 1 kW for the photovoltaic system size (pv_{size}). The difference observed in this latter variable can be explained by the plateau of the objective function irr_{inv} with respect to the variable pv_{size} , as illustrated in Figure 4.3.

The values of the design variables for pcr_{cons} and pcr_{build} are still influenced by the need to maintain the investor's IRR above zero. Furthermore, while the first objective function does not depend on β_{build} and hp_{size} and simply seeks to minimize the value of β_{cons} , the second objective function, pcr_{build} , aims to optimize both β_{build} and hp_{size} while ensuring that the investor's IRR remains above zero.

The most constraining player for heat pump size is indeed the one controlling the investor's IRR. Its objective function, in fact, decreases rapidly as hp_{size} increases, regardless of the value of β_{build} , and can even have negative values, as shown in Figure 4.5.

On the other hand, the player controlling pcr_{build} benefits from increasing hp_{size} , even though it reaches plateaus for relatively large sizes of this component, as highlighted in Figure 4.6.

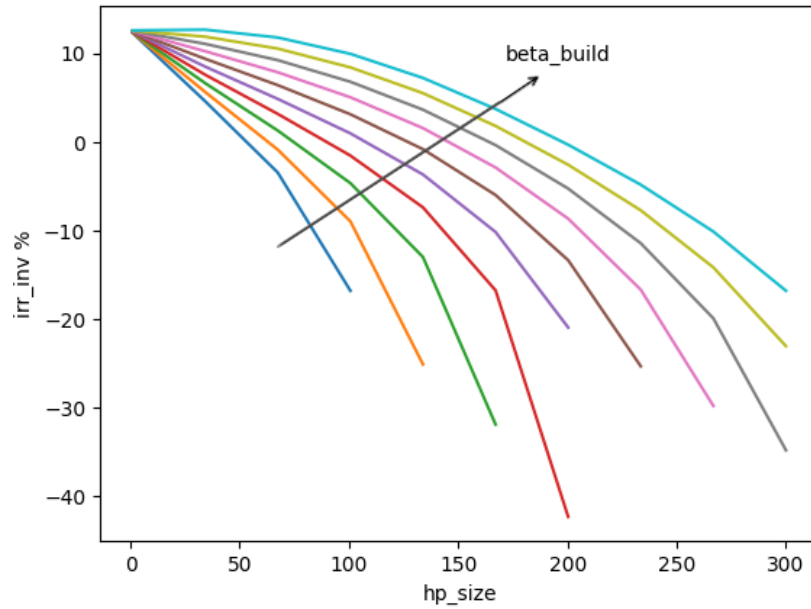

Figure 4.5: Investor's IRR trend as a function of hp_{size}

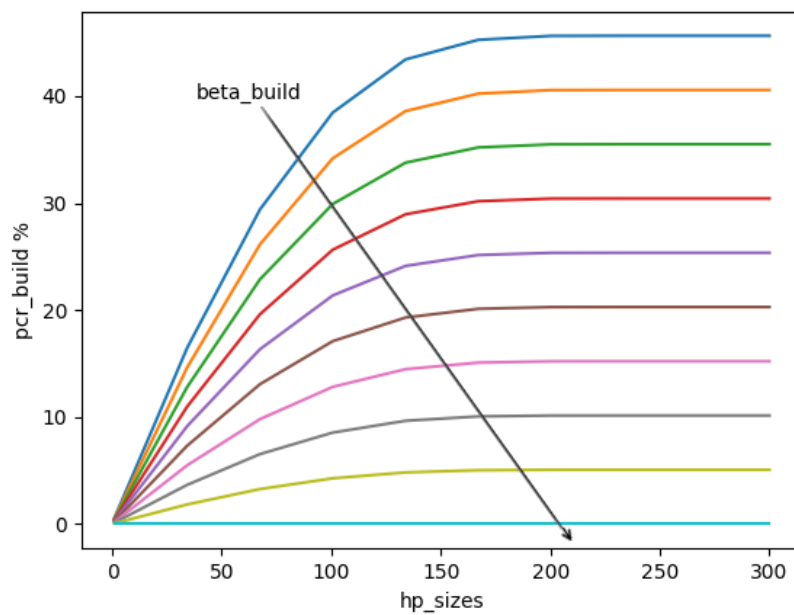

Figure 4.6: Consumer's PCR trend as a function of hp_{size}

From table 4.3, it can indeed be noticed that the values of β_{build} and hp_{size} for all solutions are very low, which can be explained by the trends shown in the previous figures. By analyzing Figure 4.4 and tables 4.3 and 4.4, it is possible to apply the same reasoning as in the Purely Electrical Case for the point closest to the Utopia and the points corresponding to the Nash Bargaining and Kalai-Smorodinsky solutions. In fact, the point closest to the Utopia is highly disadvantageous for the player controlling the investor's IRR, while the other two points are more balanced and ensure greater fairness between the players.

By comparing tables 4.2 and 4.4, it is evident that in the Electrical and Thermal case, there is a decrease in the values of irr_{inv} and pcr_{cons} compared to the Purely Electrical Case. However, in the case currently analysed, the benefits for consumers are divided into the electrical and thermal part and therefore it is interesting to analyze what happens to the value of pcr for global consumers, without distinguishing between the two aspects. Thus, combining pcr_{cons} and pcr_{build} yields:

Table 4.5: Results of the objective functions for the Electrical and Thermal Case by combining pcr_{cons} and pcr_{build}

Objective _ Functions	irr_{inv}	$pcr_{cons-global}$
Closest to Utopia	0.56%	25.28%
NB _ nadir	8.40%	17.95%
KS _ nadir	12.11%	13.88%

Comparing then the table 4.5 with the Purely Electrical Case 4.2, it can be observed that in the second investment scenario, the results are less advantageous for both the investor and the consumers.

The situation changes when considering all energy expenses and taking thermal costs into account in the first scenario. To do this, it is necessary to calculate the PCR of consumers in the Purely Electrical Case, also considering the heating expenses. In particular, it is:

Table 4.6: Results of the objective functions for the Purely Electrical Case considering thermal expenses

Objective_Functions	irr_{inv}	PCR_{cons-global}
Closest to Utopia	8.12%	18.31%
NB_nadir	12.79%	13.67%
KS_nadir	15.46%	10.72%

Therefore, considering the overall economic-energy aspect, it can be observed that the introduction of the heat pump leads to an overall improvement in the economic performance of consumers, but, at the same time, it results in a decrease in profitability for the investor.

The question that arises is what happens when one chooses to optimize the second scenario by directly considering global consumers without distinguishing between the electrical and thermal aspects. However, to do so, some modifications need to be made to the business model. Specifically, as mentioned earlier, the electrical and thermal components are combined in the calculation of $PCR_{cons-global}$ and therefore, instead of considering two variables for the allocation of economic benefits, only one variable is used: $\beta_{cons-global}$. In particular, using this business model, the obtained results of the objective functions are illustrated in Figure 4.7:

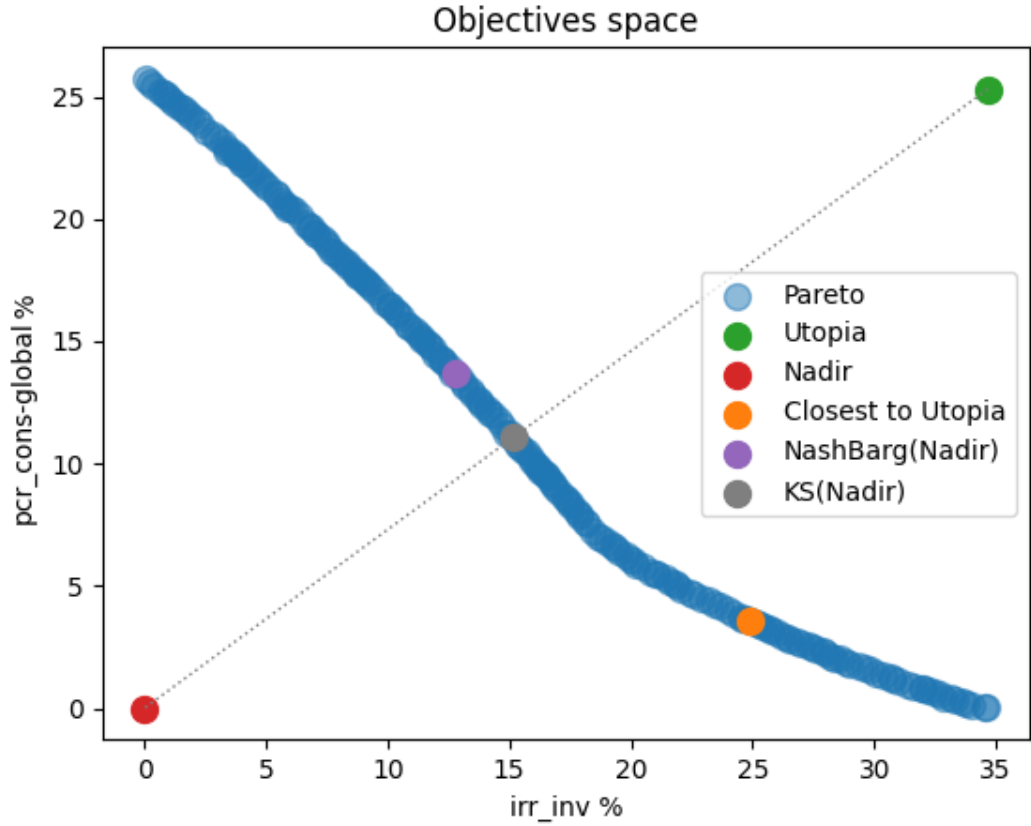

Figure 4.7: Objective function space for solutions of the Electrical and Thermal Case considering global consumers

written in tabular form:

Table 4.7: Values of the variables for the solutions of the Electrical and Thermal Case considering global consumers

Variable	PV_{size} [kW]	$\beta_{cons-global}$	hp_{size} [kW]
Utopia for irr_{inv}	16.0	1.00	0.0
Utopia for $pcr_{cons-global}$	98.0	0.40	40.0
PseudoNadir for irr_{inv}	98.0	0.40	40.0
PseudoNadir for $pcr_{cons-global}$	16.0	1.00	0.0
Closest to Utopia	35.5	0.78	0.0
NB_nadir	100.0	0.61	0.0
KS_nadir	100.0	0.68	0.0

Table 4.8: Values of the objective functions for the solutions of the Electrical and Thermal Case considering global consumers

Objective_Functions	irr_{inv}	pcr_{cons}
Utopia	34.67%	25.31%
PseudoNadir	0.00%	0.00%
Closest to Utopia	24.90%	3.59%
NB_nadir	12.79%	13.67%
KS_nadir	15.16%	11.07%

As can be observed by comparing tables 4.5 and 4.8, the use of this new business model brings an advantage to the player controlling the investor's IRR but a disadvantage to the player controlling the consumers as a whole. This occurs because the heat pump is never installed since its economic benefits seem to be not very favourable for the configuration as a whole.

The comparison between the two business models highlights several significant considerations. Initially, it can be noted that the first model may offer greater advantages and prove to be more realistic if the objective is to implement thermal efficiency within the context of collective self-consumption. This is because the first model explicitly addresses the thermal component of self-consumption, providing a more comprehensive perspective.

On the other hand, the second model may be more suitable when evaluating the situation as a whole. However, this approach carries the risk of not installing certain components, such as the heat pump in the specific case being considered. The results obtained for this new business model are practically identical to those found for the Purely Electric Case, as the optimization yields a value of zero for the size of the heat pump.

It could be hypothesized that the reason the second model neglects the installation of the heat pump is because it favors the interests of the investors more, as evident from comparing the results shown in tables 4.5 and 4.8. In the first model, there are indeed two objective functions in favor of the consumers, while in the second model, there is only one, thus placing greater importance on the investor's objective function.

4.3 Analysis without Non-Cooperative Nash Equilibrium

Since in the previous discussion it was not possible to determine the non-cooperative Nash because of the constraints imposed on the objective functions, it is now possible to perform the Game Theory MOOP without the non-cooperative Nash. This allows to simultaneously analyse a greater number of objective functions than design variables. In this context, the traditional multi-objective optimization reaches its limit (due to the excessive amount of objective functions), making it impossible to perform direct comparisons.

It has been chosen to use the business model described in Section 3.3 to obtain a more specific view of the two scenarios. The Purely Electrical Case is initially analyzed using the variables described in Section 4.1, with the following objective functions: irr_{inv} , pcr_{cons} , sci , ssi . The last two specifically refer to the electrical aspect. However, it is important to emphasize that the energy performance indicators are not influenced by the profit-sharing variable, and therefore, for these, β_{cons} only varies to ensure compliance with the constraints for the other objective functions.

Therefore, the variables of the solutions are:

Table 4.9: Values of the design variables for the solutions of the Purely Electrical Case considering also the energetic KPIs

Variable	pv_{size} [kW]	β_{cons}
Utopia for irr_{inv}	16.5	1.00
Utopia for pcr_{cons}	98.5	0.30
Utopia for sci	2.5	0.82
Utopia for ssi	100.0	0.99
PseudoNadir for irr_{inv}	98.5	0.30
PseudoNadir for pcr_{cons}	16.5	1.00
PseudoNadir for sci	100.0	0.99
PseudoNadir for ssi	2.5	0.82
NB_nadir	35.5	0.56
KS_nadir	36.0	0.46

while the values of the objective functions of the solutions are:

Table 4.10: Values of the objective functions for the solutions of the Purely Electrical Case considering also the energetic KPIs

Objective_Functions	irr_{inv}	pcr_{cons}	sci	ssi
Utopia	34.67%	53.79%	100.00%	45.31%
PseudoNadir	0.00%	0.00%	39.15%	2.95%
NB_nadir	17.00%	15.75%	87.89%	36.04%
KS_nadir	12.72%	19.74%	87.08%	36.32%

By comparing these tables with those related to the Purely Electrical Case seen earlier, 4.1 and 4.2, it can be noticed that the values of the variables and objective functions calculated for the Utopia and Nadir of the players controlling the investor's IRR and consumer's PCR remain constant. This result was already evident even without performing the calculations, as the *sci* and *ssi*, being by definition greater than zero, do not affect their calculation in any way.

Furthermore, it is possible to observe that the self-consumption is optimized with a value of approximately 3 kW for pv_{size} , but it also reaches its maximum value in a plateau phase below 20 kW. This behavior is in fact similar to what is illustrated in Figure 4.3, however, maximizing this objective function for low values of pv_{size} is not a desirable outcome. On the contrary, it is evident that the self-sufficiency is maximized by imposing the maximum size for the production system. Due to these characteristics, as indicated by the values of the Nadir, these two objective functions are in stark contrast to each other and therefore do not create an excessive imbalance in the game in favor of one party over the other.

However, with the addition of these two new objective functions, the values of the variables in the Nash Bargaining and Kalai-Smorodinsky solutions undergo a drastic change, particularly for the variable pv_{size} , which decreases from 100 kW to approximately 36 kW. This is due to the relatively strong influence of the objective function *sci*, which seeks to minimize the size of the production system.

From the perspective of the objective functions 4.10, it can be observed that ideally, *sci* could reach 100%, while *ssi* stops at 45%. The values of these objective functions calculated in the base case using the variables of the found solutions were approximately 39% and 45%, respectively. However, in this new analysis, *sci* reaches 87% and *ssi* decreases

to 36%, resulting in a more balanced approach towards the ideal values.

Regarding the Nash Bargaining solution for the irr_{inv} and pcr_{cons} , the reduction in the size of the photovoltaic system leads to an increase in the investor's IRR, as highlighted in the graph in Figure 4.3, and a decrease in consumer's PCR, as indicated by the values of the Nadir. To maintain a "balance," the Nash Bargaining solution reduces the value of β_{cons} in order to not excessively penalize the consumers. However, the equilibrium value of β_{cons} is still too high, resulting in a significant decrease in consumer's PCR, dropping from approximately 31% to 16%.

A similar situation is found for the Kalai-Smorodinsky solution, which, by modifying the variables in a similar manner, leads instead to a decrease in both these objective functions compared to the case in Table 4.2. However, the Kalai-Smorodinsky solution maintains a higher value of consumer's PCR compared to the Nash Bargaining solution. Furthermore, comparing the Kalai-Smorodinsky solutions between the Purely Electrical Case and the currently analyzed one, it might seem that the solution obtained in the latter case is worse and therefore not Pareto optimal. However, the truth is that the addition of the objective functions sci and ssi has completely changed the Pareto front. In fact, as shown earlier, if we apply the variables found for the solution of the Purely Electrical Case to this new configuration, we obtain a value for sci equal to the Nadir. This demonstrates that the solution of the base Purely Electrical Case does not dominate the solution of the new configuration.

For this reason, it is impossible to make a direct comparison between the two configurations in an absolute sense. However, it can be stated that considering the energy performance indicators, the economic feasibility tends to decrease.

For the Electrical and Thermal Case, the design variables correspond to those described in Section 4.2. The objective functions analyzed include the investor's IRR, consumer's PCR, condominium's PCR, self-consumption, and self-sufficiency. Self-consumption specifically refers to the electrical component, as the thermal energy production must be fully self-consumed by law, as explained in Chapter 2. In this scenario, self-sufficiency is instead divided into an electrical component, ssi , and a thermal component, ssi_{th} .

In this case as well, the energy performance indicators do not depend on the profit-sharing variables, and therefore, they are determined solely to satisfy the imposed constraints.

Consequently, the values of the design variables and objective functions obtained through multi-objective optimization are reported in Tables 4.11 and 4.12, respectively:

Table 4.11: Values of the design variables for the solutions of the Electrical and Thermal Case considering also the energetic KPIs

Variable	PV_{size} [kW]	β_{cons}	β_{build}	hp_{size} [kW]
Utopia for irr_{inv}	1.0	1.00	1.00	0.0
Utopia for pcr_{cons}	87.0	0.17	0.92	72.5
Utopia for pcr_{build}	100.0	0.78	0.10	78.5
Utopia for sci	11.0	0.84	0.97	11.5
Utopia for ssi	100.0	0.99	0.59	0.0
Utopia for ssi_{th}	68.5	0.82	0.87	183.0
PseudoNadir for irr_{inv}	87.0	0.17	0.92	72.5
PseudoNadir for pcr_{cons}	1.0	1.00	1.00	0.0
PseudoNadir for pcr_{build}	1.0	1.00	1.00	0.0
PseudoNadir for sci	100.0	0.99	0.59	0.0
PseudoNadir for ssi	1.0	1.000	1.000	0.0
PseudoNadir for ssi_{th}	1.0	1.00	1.00	0.0
NB_nadir	86.5	0.69	0.63	86.5
KS_nadir	70.0	0.79	0.64	96.0

Table 4.12: Values of the objective functions for the solutions of the Electrical and Thermal Case considering also the energetic KPIs

Objective_Functions	irr_{inv}	pcr_{cons}	pcr_{build}	sci	ssi	ssi_{th}
Utopia	34.67%	48.17%	32.88%	100.00%	45.31%	99.55%
PseudoNadir	0.00%	0.00%	0.00%	39.15%	1.16%	0.00%
NB_nadir	6.56%	17.55%	14.22%	58.96%	37.00%	66.44%
KS_nadir	6.54%	9.74%	14.11%	67.65%	33.37%	72.63%

By comparing these tables with the results for the base Electrical and Thermal Case, 4.3 and 4.4, it can be observed that the values of the solutions for the Utopia and Nadir of the common objective functions are the same, as expected.

From Table 4.11, it can still be observed that sci and ssi are in strong contrast, while the new objective function ssi_{th} , as it seeks to maximize the size of the heat pump, is in strong opposition to both the investor's IRR and the electrical ssi . The latter also aims to minimize the size of the heat pump since this component leads to an increase in electrical self-consumption.

By comparing the energy behavior of the Electrical and Thermal Case between the base case and this new analysis, an increase in self-consumption can be observed, from values around 45% to approximately 60%, a decrease in electrical self-sufficiency, which drops from about 43% to around 35%, and a significant increase in thermal self-sufficiency, which goes from values around 15% to over 60%. Therefore, as expected, the results of the energy indicators obtained in this new analysis are more balanced in approaching the ideal.

From an economic perspective instead, considering all the new objective functions, a reduction in the "strength" of the player controlling the investor's Interest Rate of Return can be observed. This is evident when comparing the optimization results for this case with those reported in Table 4.4. Additionally, analyzing the Nash Bargaining solution, both the values of pcr_{cons} and pcr_{build} decrease, but to a lesser extent than the IRR. On the other hand, considering the Kalai-Smorodinsky solution, the value of pcr_{cons} undergoes a significant decrease, while the value of pcr_{build} increases.

Compared to the new Purely Electrical Case, highlighted in Tables 4.9 and 4.10, a significant reduction in the percentage of self-consumed energy is observed, attributed to the larger size of the photovoltaic system, while electrical self-sufficiency remains practically unchanged. From the economic point of view instead, overall, it can be stated that the inclusion of the thermal component in this latest analysis, as well as in the previously examined cases in 4.1 and 4.2, leads to a decrease in economic benefits for the investor in favor of consumers, as well as a reduction in self-consumption in favor of thermal self-sufficiency.

4.4 Discussion of the Results

It is now possible to summarize the results obtained from the analyzed cases. Only the scenarios implemented using the first business model will be summarized since the Electrical and Thermal case, calculated using the second business model, is practically identical to the Purely Electrical case.

Considering only the economic indicators, it appears that the first analyzed case represents the most profitable investment when considered on its own, as it yields higher

values for both the Investor's Internal Rate of Return and the Consumers' Percentage Cost Reduction. However, when considering the entire energy situation of the collective self-consumption, taking into account also the thermal expenses in the Purely Electrical case, the situation changes. In fact, while it is not possible to claim that one scenario is better than the other, it is observed that the profitability of the first case decreases, especially for consumers, who have more advantageous economic indicators in the Electrical and Thermal case. From the investor's perspective, on the other hand, the Purely Electrical case remains the most advantageous scenario.

However, considering also the energy indicators, the results for the respective scenarios change. There is a general decrease in economic profitability, as one would expect, with the exception of some indicators that remain higher either for the Nash Bargaining solution or for the Kalai-Smorodinsky solution. If we compare the two new scenarios with each other, from an economic perspective, what was described earlier remains unchanged: the first scenario is more favorable for the investor, while the second scenario is more favorable for the consumers. From an energy perspective, instead, it is observed that the electrical self-sufficiency remains unchanged in both scenarios. However, the introduction of the two new objective functions in the second case, although not in direct contrast with self-consumption, affects the balance of optimization and penalizes it. As a result, the first case exhibits a significantly higher level of *sci* compared to the second case.

From this analysis, it emerges that there is no overall optimal configuration, but each has its own advantages. However, if a decision has to be made about which configuration to implement, it is considered appropriate to opt for the one that involves the use of a heat pump and is calculated through the Nash Bargaining method, considering energy indicators as well. This configuration seems to represent the best compromise as it ensures favorable results both from an environmental perspective and in terms of grid utilization, with high self-consumption and high thermal self-sufficiency. Moreover, it maintains a sufficiently high level of convenience for the consumers.

However, it should be emphasized that its main disadvantage is the relatively low investor's IRR. Therefore, in case there is a need for higher profitability for the investor, it is considered more appropriate to implement the configuration calculated using the KS

method, with the heat pump but without the energy indicators.

Chapter 5

Conclusions

This thesis presents the implementation of a multi-objective optimization model based on Game Theory. The reasons and methodologies of this model are explained in Chapter 1, while the main findings can be extracted from Chapter 4. It is important to highlight that although this work utilized the Game Theory MOOP to optimize the sizing of a collective self-consumption system, the model itself possesses more general characteristics and can be applied in various contexts. Therefore, the conclusions drawn are of general nature and are not limited to energy system optimization.

In particular, through the analysis of the optimized scenarios, namely the Purely Electrical Case and the Electrical and Thermal Case, it was possible to compare the multi-objective optimization based on Game Theory with the traditional approach. In the latter, the most commonly selected point is the closest to the Utopia. However, as mentioned earlier, this point does not consider the shape of the Pareto front and may favor one objective function at the expense of another. On the contrary, the results obtained through Game Theory MOOP, due to their underlying axioms, provide more "fair" solutions for the different objective functions, avoiding imbalances. It is important to note that all computed solutions are Pareto optimal, so it is not possible to claim that one is inherently better than the other. However, thanks to the enhanced fairness provided by Game Theory, which is always guaranteed, it appears that this approach can offer additional insights in multi-objective analysis, at least in specific situations.

Another challenge of traditional MOOP is the difficulty of simultaneously optimizing more than three objective functions. However, this does not pose a significant obstacle

for the Game Theory-based approach, as highlighted in Section 4.3. It is important to note, however, that Game Theory MOOP also has its limitations. In fact, with an excessively high number of objective functions, it may become challenging to reach an optimal solution, or the optimization time required may become excessive. This was also observed in the analyzed examples, as the increase in the number of objective functions and variables, and thus the complexity of the optimization, resulted in progressively longer execution times.

A comparison between two different business models was also conducted in Section 4.2. The main difference between the two lies in the division of collective self-consumption into electrical and thermal parts in the first model, while the second model considers the collective self-consumption as a whole entity. It emerged that the first model assigns greater importance to consumers since they have more objective functions resulting from the division of energy components, thus playing a dominant role in the cooperative game. On the other hand, the second model reduces the number of the consumers' objective functions, giving more relevance to the investor. The first business model also allows for a more accurate analysis of the behavior of collective self-consumption when thermal improvements are considered from the outset. Instead, the second model, being more general, risks overlooking the importance of such improvements. By utilizing these two models, the results presented in Tables 4.5 and 4.8 are obtained. It should be noted that it is not possible to claim that the solutions described in the first table are worse or better than those in the second table. Rather, the importance attributed to different players varies between the models.

This aspect highlights another important characteristic of multi-objective optimization based on Game Theory, which is the need to adequately define the problem to be optimized. A simple example emerges from this discussion: if the primary drivers of collective self-consumption are the consumers or if thermal efficiency also needs to be considered, then implementing the optimization through the first business model is more advantageous. On the other hand, if the promoter is an investor or if encouraging the investor's participation is the goal, then implementing the optimization using the second business model appears more appropriate.

From the discussion carried out, the difficulty of adequately explaining the obtained

results has also emerged, as cooperative methods analyze the game as a "black box". They provide an optimized solution through a super-criterion that satisfies the predetermined axioms but do not reflect the steps necessary to reach that solution. This is in contrast to the non-cooperative Nash game, which delves more into the optimization and its details. However, this point presents several limitations that have emerged in the discussion. Firstly, it does not guarantee that the solutions lie on the Pareto front, making its solution less desirable. In this thesis, in fact, the non-cooperative Nash equilibrium point was not considered as a solution but rather as a possible starting point to determine the solutions. Furthermore, this equilibrium point does not allow for a number of objective functions greater than the number of variables, which can be highly limiting in cases where there are few design variables. Finally, as explained in Section 1.1.1.2, the last problem in the context of non-cooperative Nash lies in the difficulty of applying constraints to the objective functions. Unlike the first two problems, which are intrinsic to this method, there are possibilities to solve this last problem, but it requires further investigation to be adequately addressed.

Therefore, Game Theory-MOOP proves to be a feasible methodology that yields satisfactory results. It can be used individually by selecting one of the proposed solutions or the obtained solutions can be combined with others. For instance, they can be combined with solutions obtained by maximizing or minimizing different objective functions or using other solutions from Game Theory MOOP calculated from specific disagreement points. This allows for obtaining insights into possible optimal configuration and analyzing trade-offs without the need to determine the entire Pareto front.

Bibliography

- [1] European Commission - "*Comunicazione al parlamento europeo, al consiglio, al comitato economico e sociale europeo e al comitato delle region. Il Grenn Deal Europeo*". Bruxelles, 11.12.2019 COM (2019) 640 final
- [2] European Commission - "*Comunicazione della commissione al parlamento europeo, al consiglio, al comitato economico e sociale europeo, al comitato delle regioni e alla banca europea per gli investimenti. Energia pulita per tutti gli europei*". Bruxelles, 30.11.2016 COM (2016) 860 final
- [3] Decree-Law of December 30, 2019, No. 162. (2019). Official Gazette of the Italian Republic, General Series, No. 306, December 31, 2019. Retrieved from "<https://www.gazzettaufficiale.it/eli/id/2019/12/31/19G00171/sg1>."
- [4] Wikipedia. Multi-objective optimization. Available on : "https://en.wikipedia.org/wiki/Multi-objective_optimization" (2023)
- [5] Binois, Mickael, Abderrahmane Habbal, and Victor Picheny. "*A game theoretic perspective on Bayesian multi-objective optimization*." arXiv preprint arXiv:2104.14456 (2021).
- [6] Iorio, Lorenzo, et al. "*Application of the Kalai-Smorodinsky approach in multi-objective optimization of metal forming processes*." International Journal of Material Forming 10 (2017): 515-526.
- [7] Nagarajan, Mahesh, and Greys Sošić. "*Game-theoretic analysis of cooperation among supply chain agents: Review and extensions*." European journal of operational research 187.3 (2008): 719-745.
- [8] Annamdas, Kiran K., and Singiresu S. Rao. "*Multi-objective optimization of engineering systems using game theory and particle swarm optimization*." Engineering optimization 41.8 (2009): 737-752.
- [9] Tang, Zhili, J-A. Désidéri, and Jacques Périaux. "*Multicriterion aerodynamic shape design optimization and inverse problems using control theory and Nash games*." Journal of Optimization Theory and Applications 135.3 (2007): 599-622.
- [10] Tang, ZhiLi, Wen Bai, and Jun Dong. "*Distributed optimization using virtual and real game strategies for multi-criterion aerodynamic design*." Science in China Series E: Technological Sciences 51.11 (2008): 1939-1956.

- [11] Tang, Zhili, Jacques Périaux, and Jun Dong. "*Constraints handling in Nash/Adjoint optimization methods for multi-objective aerodynamic design.*" Computer Methods in Applied Mechanics and Engineering 271 (2014): 130-143.
- [12] Trejo, Kristal K., and Julio B. Clempner. "*Setting Nash Versus Kalai–Smorodinsky Bargaining Approach: Computing the Continuous-Time Controllable Markov Game.*" New Perspectives and Applications of Modern Control Theory: In Honor of Alexander S. Poznyak (2018): 335-369.
- [13] Nash Jr, John F. "*The bargaining problem.*" Econometrica: Journal of the econometric society (1950): 155-162.
- [14] Kalai, Ehud, and Meir Smorodinsky. "*Other solutions to Nash’s bargaining problem.*" Econometrica: Journal of the Econometric Society (1975): 513-518.
- [15] Binois, Mickaël, et al. "*The Kalai-Smorodinsky solution for many-objective Bayesian optimization.*" The Journal of Machine Learning Research 21.1 (2020): 5978-6019.
- [16] pymoo. "NSGA-II — pymoo documentation." Retrieved from: "<https://pymoo.org/algorithms/moo/nsga2.html> "
- [17] Wikipedia. Test functions for optimization. Available on : "https://en.wikipedia.org/wiki/Test_functions_for_optimization (2023)
- [18] SciPy. "scipy.optimize.shgo - SciPy v1.7.1 Reference Guide." Retrieved from: "<https://docs.scipy.org/doc/scipy/reference/generated/scipy.optimize.shgo.html>"
- [19] Stefan C. et al. (2018), "*shgo: Simplicial homology global optimisation* "
- [20] pymoo. "GA: Genetic Algorithm — pymoo documentation." Retrieved from: "<https://pymoo.org/algorithms/soo/ga.html#nb-ga>"
- [21] pymoo. "DE: Differential Evolution — pymoo documentation." Retrieved from: "<https://pymoo.org/algorithms/soo/de.html#nb-de>"
- [22] pymoo. "Nelder Mead — pymoo documentation." Retrieved from: "<https://pymoo.org/algorithms/soo/nelder.html#nb-nelder-mead>"
- [23] Nelder, John A., and Roger Mead. "A simplex method for function minimization." The computer journal 7.4 (1965): 308-313.
- [24] pymoo. "Pattern Search — pymoo documentation." Retrieved from: "<https://pymoo.org/algorithms/soo/pattern.html#Pattern-Search>"
- [25] Robert Hooke and T. A. Jeeves. “ direct search” solution of numerical and statistical problems. J. ACM, 8(2):212–229, April 1961.
- [26] pymoo. "Evolutionary Strategy — pymoo documentation." Retrieved from: "<https://pymoo.org/algorithms/soo/es.html#nb-es>"

- [27] RSE. (2020). "*DOSSIER - Gli schemi di Autoconsumo Collettivo e le Comunità dell'Energia*", Retrieved from: <https://dossierse.it/17-2020-gli-schemi-di-autoconsumo-collettivo-e-le-comunita-dellenergia/>.
- [28] Lazzeroni, Paolo, et al. "*Modeling of Renewable Energy Communities: the RECoupled approach*." 2022 IEEE 46th Annual Computers, Software, and Applications Conference (COMPSAC). IEEE, 2022.
- [29] Gulli, Francesco, et al. "*Recoupled: a simulation tool for renewable energy communities coupling electric and thermal energies*." ECONOMICS AND POLICY OF ENERGY AND THE ENVIRONMENT (2023).
- [30] Energy & Strategy Group, "*Electricity Market Report*" Nov. 2020.
- [31] Canova, Aldo, et al. "*Decarbonizing residential energy consumption under the Italian collective self-consumption regulation*." Sustainable Cities and Society 87 (2022): 104196.
- [32] RSE. (2023). "*DOSSIER - CER e Autoconsumo collettivo: alcune simulazioni numeriche alla luce della nuova regolazione*", Retrieved from: <https://dossierse.it/19-2023-cer-e-autoconsumo-collettivo-alcune-simulazioni-numeriche-alla-luce-della-nuova-regolazione/>.
- [33] Italian Revenue Agency. "*Agevolazioni per il risparmio energetico*" [Online]. Available: "<https://www.agenziaentrate.gov.it/portale/web/guest/aree-tematiche/casa/agevolazioni/agevolazioni-risparmio-energetico>"
- [34] JRC. "*Photovoltaic Geographical Information Tool*," [Online]. Available on: "https://re.jrc.ec.europa.eu/pvg_tools/en/".
- [35] V. Corrado, I. Ballarini, S. Corgnati, Building Typology Brochure - Italy, https://episcopo.eu/fileadmin/tabula/public/docs/brochure/IT_TABULA_TypologyBrochure_POLITO.pdf
- [36] JRC, Typical Meteorological Year generator. Available on: "https://joint-research-centre.ec.europa.eu/pvgis-online-tool/pvgis-tools/pvgis-typical-meteorological-year-tmy-generator_en".
- [37] DPR412/93, "*Regolamento recante norme per la progettazione, l'installazione, l'esercizio e la manutenzione degli impianti termici degli edifici ai fini del contenimento dei consumi di energia*", Available on: "https://www.bosettiegatti.eu/info/norme/statali/1993_0412.htm" (1993).